



**NIBE**

## Air/water heat pump

### **NIBE S2060**

**NIBE S2060 is an intelligent, compact and inverter-controlled air/water heat pump with a more climate-friendly refrigerant. NIBE S2060 provides optimised savings by automatically adapting to your home's output requirements all year round.**

The heat pump works down to an outdoor temperature of  $-25^{\circ}\text{C}$  and at the same time supplies up to  $75^{\circ}\text{C}$  in supply line temperature. The effective cooling function allows the heat pump to deliver a comfortable indoor climate even at high outdoor temperatures. It also has a more climate-friendly refrigerant to provide less impact on the environment. Available in two sizes 6 and 10.

Thanks to smart technology, the product gives you control over your energy consumption and will be a key part of your connected home. The efficient control system automatically adjusts the indoor climate for high comfort, and you do nature a favour at the same time.



- **Compact heat pump that adapts to your home's requirements with a new, more climate-friendly refrigerant to provide less impact on the environment.**
- **High capacity even down to  $-25^{\circ}\text{C}$  and effective cooling function.**
- **Energy-saving smart technology with user-friendly control.**

# This is how NIBE S2060 works

## Installation method

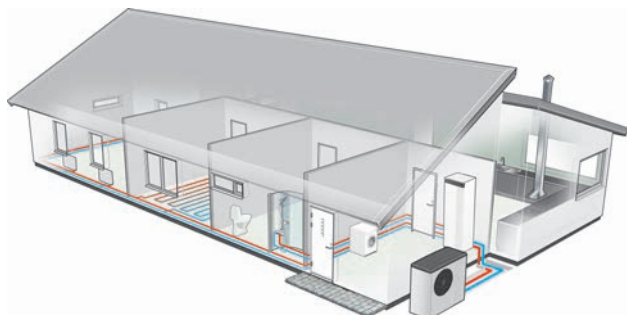

### SYSTEM SOLUTIONS

Go to [NIBE Compatibility](#) or scan the QR code below.



This provides information about possible combinations with S2060. (Some products are not sold in all markets).

S2060 – a part of your climate system where S2060 is intended to be combined with one of the indoor modules or the control modules.

Together with an indoor module, S2060 creates a complete heating/cooling and hot water system. Our flexible indoor modules provide efficient heating and high hot water performance. The indoor modules are complete with a smart, user-friendly control system, hot water heater, additional heat, self-regulating circulation pump, etc.

The control modules offer a flexible system solution that can be easily customised. For systems with a control module, different components, such as water heaters, additional heat and other accessories, can be selected to suit the installation's requirements.

There is a wide range of system solutions and accessories for NIBE's indoor modules and control modules.

### PRINCIPLE OF OPERATION

Principle of operation with indoor module, hot water and climate system.

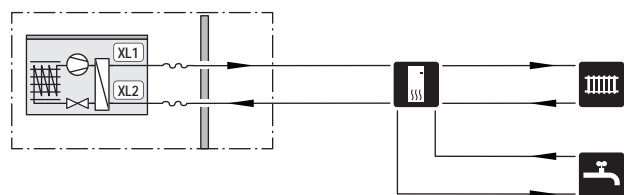

- XL1 Heating medium connection, supply (out from S2060)
- XL2 Heating medium connection, return (to S2060)

# Good to know about NIBE S2060

## Transport

S2060 should be transported and stored vertically in a dry place.

Ensure that the heat pump cannot fall over during transport.

Check that S2060 has not been damaged during transport.

### **LIFT TO INSTALLATION LOCATION**

If the heat pump needs to be transported across soft ground, such as a lawn, we recommend using a crane truck that can lift it to the installation location.

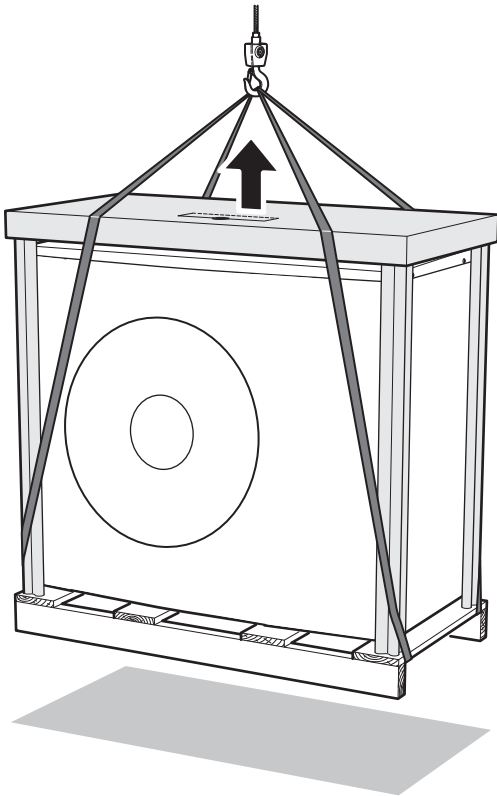

## Installation and positioning

- Place the heat pump in a suitable location outdoors to prevent any risk of the refrigerant flowing in through ventilation openings, doors or similar openings in the event of a leak. It must also not constitute a hazard to people or property in any other way.
- If the heat pump is placed in a location where any refrigerant leak could accumulate, for example below ground level (in a dip or low-lying recess), the installation must satisfy the same requirements that apply for gas detection and the ventilation of engineering rooms. Requirements regarding sources of ignition must be applied where appropriate. Follow local rules and regulations.
- Place S2060 outdoors on a solid level base that can take the weight, preferably a concrete foundation. If concrete slabs are used they must rest on asphalt or shingle.
- S2060 should not be positioned next to noise sensitive walls, for example, next to a bedroom.
- Also ensure that the placement does not inconvenience the neighbours.
- S2060 must not be placed so that recirculation of the outdoor air is possible. Recirculation entails reduced power and impaired efficiency.
- The evaporator must be sheltered from direct wind / , which negatively affects the defrosting function. Place S2060 protected from wind / against the evaporator.
- Do not install S2060 in locations where there might be substances in the atmosphere that might affect the unit, such as sulphide gas, chlorine, acid or alkaline substances, very salty air.
- Do not install S2060 in locations where powder may be present in the air, such as carbon fibre, metal powder.
- Large amounts of condensation, as well as melt water from defrosting, may be produced. Use the accessory KVR, see section "Condensate drip tray".
- If there is a risk of snow slip from roof, a protective roof or cover must be erected to protect the heat pump, pipes and wiring.

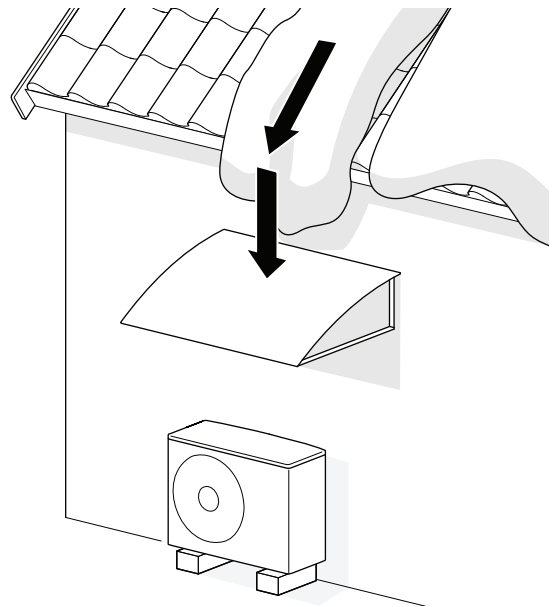

### INSTALLATION AREA

Leave a free space of at least 200 mm between S2060 and the house wall, but not more than 500 mm in windy locations.

Leave a free space of 1,000 mm in front of, and 1,000 mm above, the product.

Approx. 500 mm free space is needed on the right-hand side to allow the front panel to be removed.

The lower edge of the evaporator must not be lower than the level of the average local snow depth, or at least 300 mm above ground level. The base should be at least 70 mm tall.

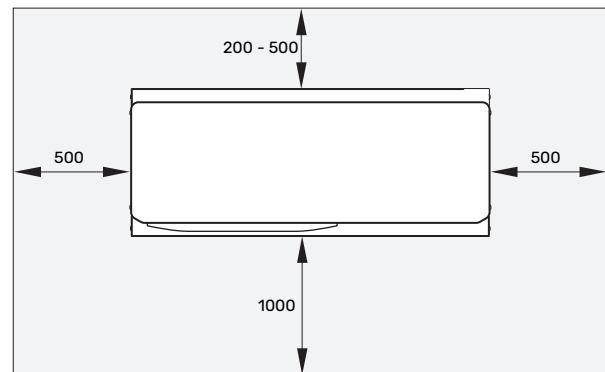

## Supplied components

Local differences in the enclosed kit may occur. See relevant installer manual for more information.

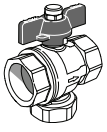

Filterball (G1")

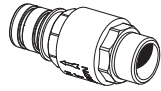

Non-return valve

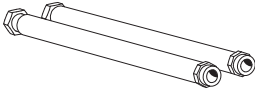

Flexible hoses  
(Dimensions DN25, G1")  
Including gaskets (4 pcs)

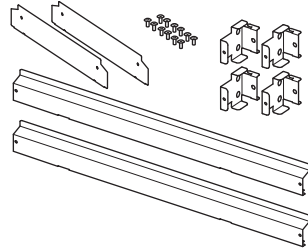

Plinth

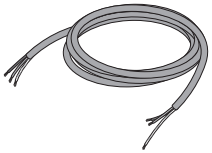

Power supply cable (W1)

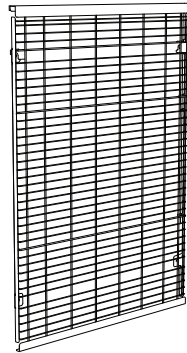

Fan grille  
Screws (4 pcs)

# Installation

## Inspection of the installation

Current regulations require the heating installation to be inspected before it is commissioned. The inspection must be carried out by a suitably qualified person and should be documented. The above applies to closed heating systems.

If the heat pump is replaced, the installation must be inspected again.

## Condensation water trough

The condensate drain pan collects and leads away the condensation water.

It is important to the heat pump function that condensation water is led away and that the drain for the condensation water run off is not positioned so that it can cause damage to the house.

Pipe with heating cable (KVR), for draining the condensate drip tray, is not included. To guarantee this function, the accessory KVR should be used.

## Pipe connections

### MINIMUM SYSTEM FLOW DEFROSTING

An undersized climate system can result in damage to the product and lead to malfunctions.

The dimensions of the pipes between the indoor module and the heat pump should not be less than the recommended pipe diameter. The climate system must be dimensioned individually to provide the recommended system flows.

The installation must be dimensioned to provide the minimum defrosting flow at 100 % circulation pump operation.

Air/water heat pump	Minimum flow during defrosting 100% circulation pump operation (l/s)	Minimum recommended pipe dimension (DN)	Minimum recommended pipe dimension (mm)
S2060-6	0.14	20	22
S2060-10	0.21	20	22

### WATER VOLUMES

To prevent short operating times, and to enable defrosting, a certain available water volume is required. For the optimum operation of S2060, a minimum available water volume is recommended, see table. This applies separately to heating and cooling systems.

S2060	6	10
Minimum volume, climate system during heating/cooling	20 l	50 l
Minimum volume, climate system during under floor cooling	50 l	80 l

# Technical data

## Dimensions

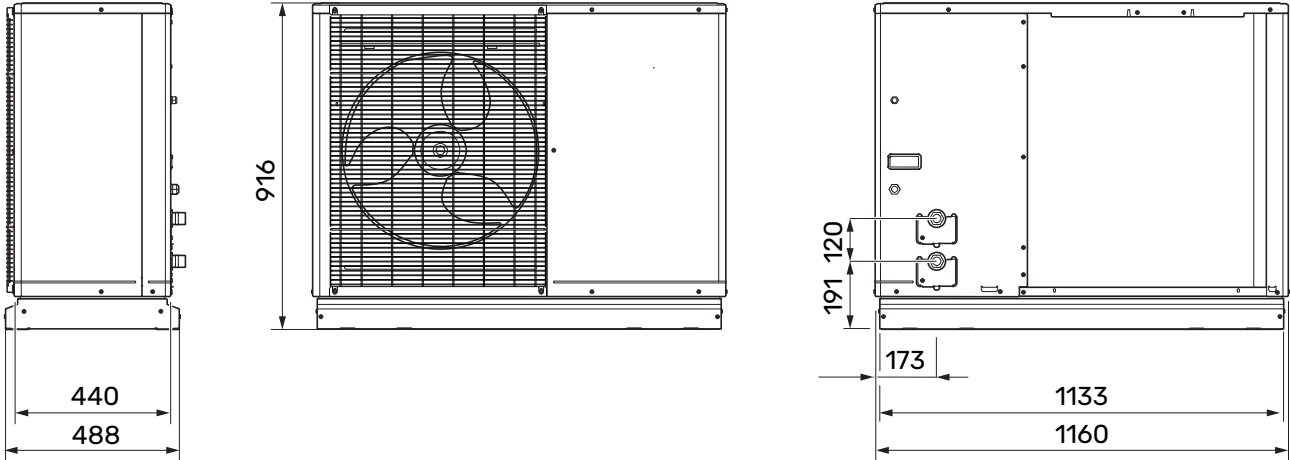

## Sound levels

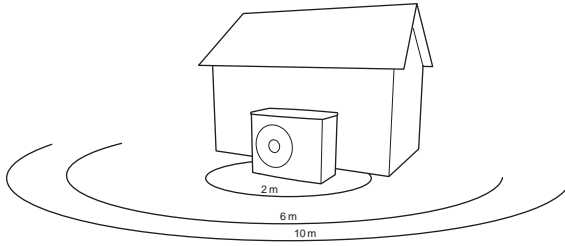

S2060 is usually placed next to a house wall, which gives a directed sound distribution that has to be taken into consideration. Accordingly, when setting up, you should always attempt to select the side that faces the least sound-sensitive neighbouring area.

The sound pressure levels are further affected by walls, bricks, differences in ground level, etc and should therefore only be seen as guide values.

S2060 adjusts the fan speed depending on the ambient temperature and evaporation temperature.

		Sound power <sup>1</sup>	Sound pressure at distance (m) <sup>2</sup>									
			1	2	3	4	5	6	7	8	9	10
S2060-6	Nominal sound value	51	46.0	40.0	36.5	34.0	32.0	30.5	29.0	28.0	27.0	26.0
	Max. sound value	57	52.0	46.0	42.5	40.0	38.0	36.5	35.0	34.0	33.0	32.0
	Max. sound value, silent mode	50	45.0	39.0	35.5	33.0	31.0	29.5	28.0	27.0	26.0	25.0
S2060-10	Nominal sound value	54	49.0	43.0	39.5	37.0	35.0	33.5	32.0	31.0	30.0	29.0
	Max. sound value	60	55.0	49.0	45.5	43.0	41.0	39.5	38.0	37.0	36.0	35.0
	Max. sound value, silent mode	53	48.0	42.0	38.5	36.0	34.0	32.5	31.0	30.0	29.0	28.0

<sup>1</sup> Sound power level,  $L_w(A)$ , according to EN12102

<sup>2</sup> Sound pressure calculated according to directivity factor  $Q=4$

# Technical specifications

## TECHNICAL SPECIFICATIONS

### Working range, heating

Supply temperature (°C)

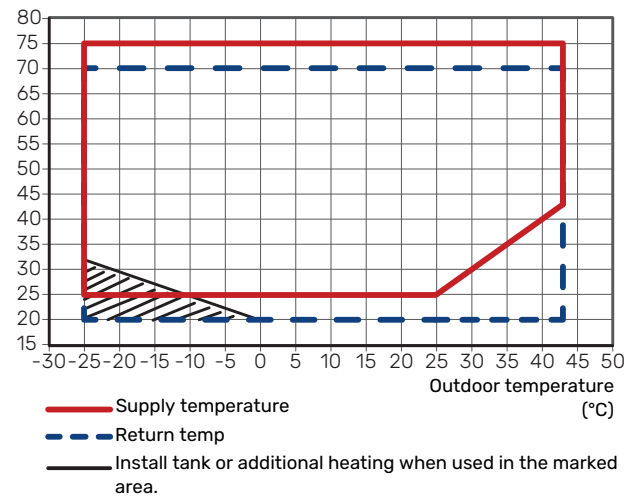

### Power during heating operation

Maximum and minimum capacity during continuous operation. Defrosting is not included.

#### S2060-6

Heating output (kW)

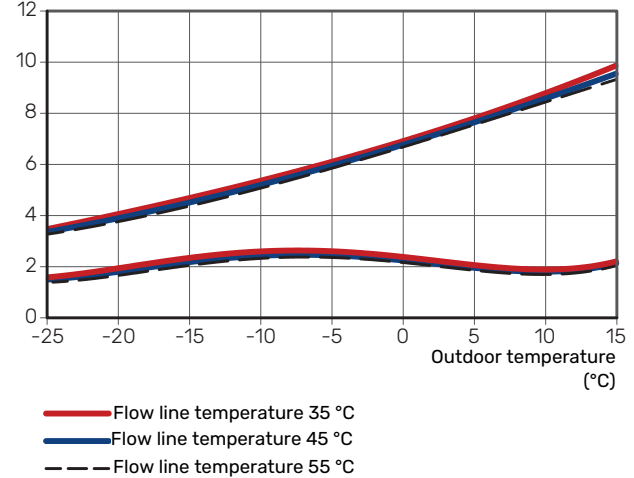

### Working range, cooling

Supply temperature (°C)

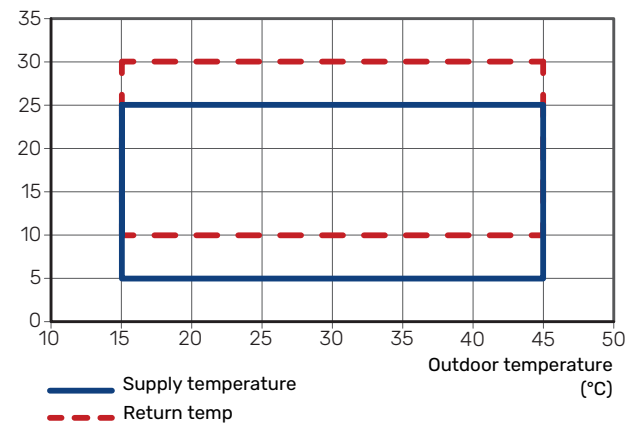

#### S2060-10

Heating output (kW)

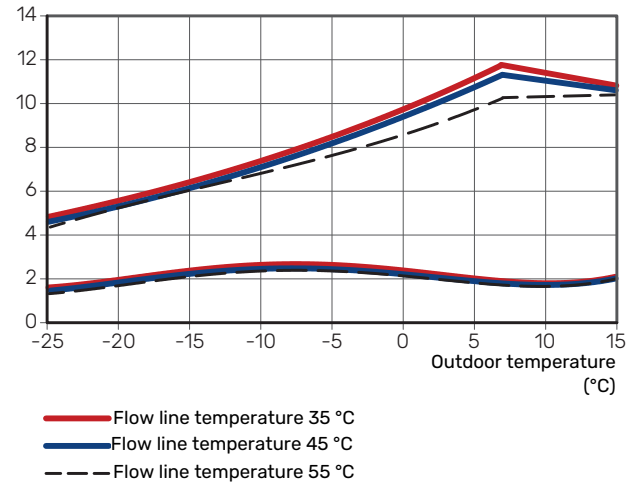

During shorter time it is allowed to have lower working temperatures on the water side, e.g. during start up.

## Power during cooling operation

Maximum and minimum capacity during continuous operation.

### S2060-6

Cooling output

(kW)

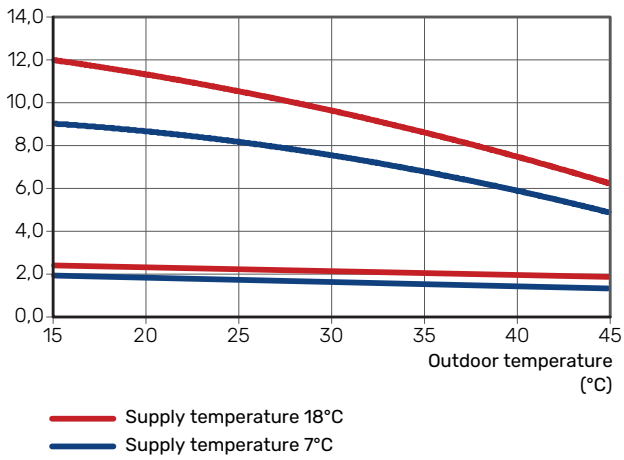

### S2060-10

Cooling output

(kW)

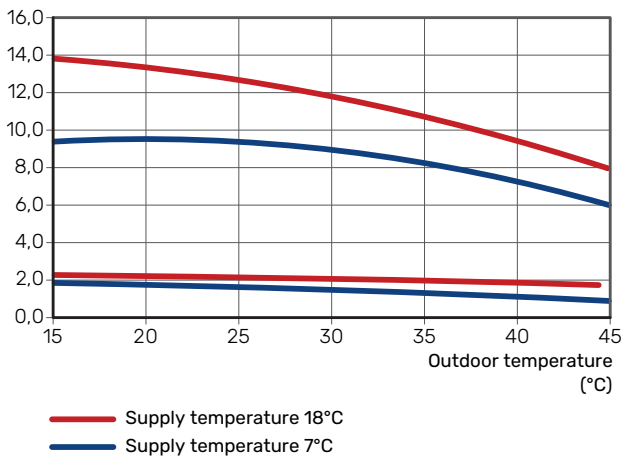

<b>S2060</b>		<b>6</b>	<b>10</b>
<b>Voltage</b>		<b>1 x 230 V</b>	<b>1 x 230 V</b>
<b>Output data according to EN 14 511, partial load<sup>1</sup></b>			
Heating	-7 / 35 °C	5.17 / 1.85 / 2.79	6.70 / 2.53 / 2.65
Capacity / power input / COP (kW/kW/-) at nominal flow Outdoor temp: / Supply temp.	2 / 35 °C	3.32 / 0.68 / 4.88	3.61 / 0.76 / 4.77
	2 / 45 °C	3.70 / 0.98 / 3.78	4.26 / 1.27 / 3.35
	7 / 35 °C	4.92 / 0.89 / 5.53	6.02 / 1.11 / 5.42
	7 / 45 °C	4.28 / 0.99 / 4.32	5.70 / 1.34 / 4.25
Cooling	35 / 7 °C	4.64 / 1.28 / 3.63	5.73 / 1.61 / 3.56
Capacity / power input / EER (kW/kW/-) at maximum flow Outdoor temp: / Supply temp.	35 / 18 °C	8.48 / 2.33 / 3.64	10.76 / 2.66 / 4.05
<b>Maximum capacity</b>			
Maximum capacity, heating, at A7W35 without defrosting	kW	8.27	11.73
Maximum capacity, heating, at A2W55 with / without defrosting	kW	5.54 / 6.91	7.14 / 9.06
Maximum capacity, heating, at A-7W35 without defrosting	kW	5.78	8.04
<b>SCOP according to EN 14825</b>			
Nominal heat output (P <sub>designh</sub> ) average climate 35 °C / 55 °C (Europe)	kW	4.8 / 5.3	6.5 / 7.0
Nominal heat output (P <sub>designh</sub> ) cold climate 35 °C / 55 °C	kW	5.5 / 5.7	8.0 / 7.8
Nominal heat output (P <sub>designh</sub> ) warm climate 35 °C / 55 °C	kW	5.2 / 5.5	6.5 / 7.2
SCOP average climate, 35 °C / 55 °C (Europe)		5.33 / 4.19	5.07 / 4.02
SCOP cold climate, 35 °C / 55 °C		4.12 / 3.63	4.42 / 3.59
SCOP warm climate, 35 °C / 55 °C		6.64 / 5.06	6.46 / 4.83
<b>Energy rating, average climate<sup>2</sup></b>			
The product's room heating efficiency class 35 °C / 55 °C <sup>3</sup>		A+++ / A+++	A+++ / A+++
The system's room heating efficiency class 35 °C / 55 °C <sup>4</sup>		A+++ / A+++	
<b>Electrical data</b>			
Rated voltage		230 V ~ 50 Hz	230 V ~ 50 Hz
Max. power, fan	W	59	
Fuse	A <sub>rms</sub>	16	
Enclosure class		IP24	
<b>Refrigerant circuit</b>			
Type of refrigerant		R290	
GWP refrigerant		0.02	
Filling amount	kg	0.65	0.85
Type of compressor		Rotary compressor	Rotary compressor
CO <sub>2</sub> -equivalent (The cooling circuit is hermetically sealed.)	kg	0.013	0.017
<b>Airflow</b>			
Max airflow	m <sup>3</sup> /h	42	50
<b>Working area</b>			
Min./max. air temperature, heating	°C	-25 / 43	
Min./max. air temperature, cooling	°C	15 / 45	
<b>Heating medium circuit</b>			
Max system pressure heating medium	MPa (bar)	0.3 (3.0)	
Cut-off pressure, heating medium	MPa (bar)	0.3 (3.0)	
Recommended flow interval, heating operation	l/s	0.08 – 0.42	0.12 – 0.50
Min. design flow, defrosting (100% pump speed)	l/s	0.14	0.21
Min./max. HM temp, continuous operation	°C	25 / 75	
Min./max. HM temp, continuous operation, cooling	°C	5 / 25	
Connection heating medium S2060		G1" external thread	
Connection heating medium flex pipe		G1" external thread	
Min. recommended pipe dimension (system)	DN (mm)	DN (mm) 20 (22)	
<b>Dimensions and weight</b>			
Width	mm	1,160	1,160
Depth	mm	488	488
Height	mm	916	916
Weight	kg	84	91
<b>Miscellaneous</b>			

S2060		6	10
Part no.		064 381	064 382

- 1 Power statements including defrosting according to EN 14511 at heating medium supply corresponding to DT=5 K at 7 / 45.
- 2 The reported efficiency of the package also takes the controller into account. If an external supplementary boiler or solar heating is added to the package, the overall efficiency of the package should be recalculated.
- 3 Scale for the product's efficiency class room heating: A+++ to D. Control module model SMO S
- 4 Scale for the system's efficiency class room heating: A+++ to G. Reported efficiency for the system takes the product's temperature regulator into account. Control module model SMO S

## Accessories

Detailed information about the accessories and complete accessories list available at [nibe.eu](http://nibe.eu).

Not all accessories are available on all markets.

### Condensation water pipe KVR

#### KVR 15-10

1 metres

Part no. 267 025

#### KVR 15-30

3 metres

Part no. 267 026

#### KVR 15-60

6 metres

Part no. 267 027

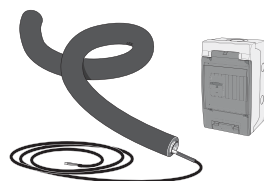

### Stand and brackets

#### Ground stand GSU 40

For the installation of S2060 on the ground.

S2060-6, -10

Part no. 067 965

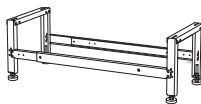

#### Wall rack BAU 50

Wall mounting of S2060.

Part no. 267 017

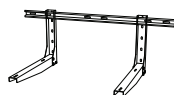







# Sustainable energy solutions since 1952

---

NIBE has since 1952 been manufacturing energy-efficient and sustainable climate solutions for your home. It all began in Markaryd, in the southern Swedish province of Småland, and we recognise our Nordic heritage by utilising the power of nature. We combine renewable energy with smart technology to offer efficient solutions, allowing us to work together to create a more sustainable future.

Regardless of whether it is a chilly winter's day or a warm afternoon in the summer sun, we need a balanced indoor climate that allows us to enjoy a comfortable life, whatever the weather. Our extensive range of products supply your home with cooling, heating, ventilation and hot water, making it possible for you to create a pleasant indoor climate with little impact on the environment.

NIBE Energy Systems  
Box 14, SE-285 21 Markaryd  
nibe.eu

**NIBE**

---

This product sheet is a publication from NIBE Energy Systems. All product illustrations, facts and data are based on current information at the time of the publication's approval. NIBE Energy Systems makes reservations for any factual or printing errors in this product sheet.

©2026 NIBE ENERGY SYSTEMS  
PBD EN 2610-1 M13483