

Air/water heat pump

NIBE S2060 6, 10



Table of Contents

1	Important information _____	4	8	Service _____	24
	Safety information _____	4		Service actions _____	24
	Symbols _____	4			
	Marking _____	4	9	Disturbances in comfort _____	25
	Serial number _____	4		Troubleshooting _____	25
	Inspection of the installation _____	5		Alarm list _____	26
	System solutions _____	5	10	Accessories _____	29
2	Delivery and handling _____	6	11	Technical data _____	30
	Transport _____	6		Dimensions _____	30
	Assembly _____	6		Sound levels _____	31
	Condensation _____	8		Technical specifications _____	32
	Supplied components _____	9		Energy labelling _____	36
	Installing the enclosed plinth _____	9		Electrical circuit diagram _____	40
	Handling panels _____	10		Item register _____	41
	Dismantling cardboard box _____	10		Contact information _____	43
	Removing the transport safety devices _____	10			
	Installing the enclosed fan grille _____	11			
3	The heat pump design _____	12			
	General _____	12			
4	Pipe connections _____	16			
	General _____	16			
	Symbol key _____	16			
	Pipe coupling heating medium circuit _____	17			
5	Electrical connections _____	18			
	General _____	18			
	Accessibility, electrical connection _____	18			
	Connections _____	19			
6	Commissioning and adjusting _____	20			
	Filling _____	20			
	Venting _____	20			
	Commissioning _____	20			
	Adjustment, charge flow _____	20			
	Charge pump _____	20			
	Pressure drop, heating medium side _____	20			
7	Control _____	21			
	General _____	21			
	Activating S2060 _____	22			

Important information

Safety information

This manual describes installation and service procedures for implementation by specialists.

The manual must be left with the customer.

For the latest version of the product's documentation, see nibe.eu.



CAUTION!

Read the enclosed safety manual before installation or servicing.

Symbols

Explanation of symbols that may be present in this manual.



CAUTION!

This symbol indicates danger to person or machine.



NOTE!

This symbol indicates important information about what you should consider when installing or servicing the installation.



TIP!

This symbol indicates tips on how to facilitate using the product.

Marking

Explanation of symbols that may be present on the product's label(s).



Fire hazard!



Read the User Manual.



Read the Installer Manual.

Serial number

The serial number for S2060 can be found on the side of the foot on the type plate (PZ1).

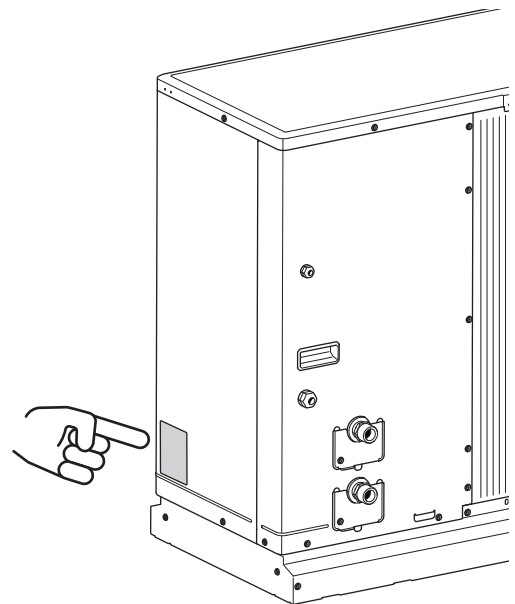

NOTE!

You need the product's serial number for servicing and support.

Inspection of the installation

Current regulations require the heating installation to pass an installation inspection before it is commissioned. The inspection must be carried out by a suitably qualified person. In addition, complete the page in the User Manual for information about the installation data.

✓	Description	Notes	Signature	Date
	Heating medium (page 17)			
	System flushed			
	System vented			
	Particle filter			
	Shut-off and drain valve			
	Non-return valve			
	Charge flow set			
	Electricity (page 18)			
	Fuses property			
	Safety breaker			
	Earth circuit-breaker			
	Heating cable type/effect			
	Fuse size, heating cable (F3)			
	Communication cable connected			
	S2060 addressed (only when cascade connection)			
	Cooling permitted			
	Connections			
	Main voltage			
	Phase voltage			
	Update to the latest version of the software in the indoor module/control module.			
	Miscellaneous			
	Condensation water pipe			
	Insulation for condensation water pipe, thickness (unless KVR is used)			

System solutions

Go to [CompatibilityAWHP](#) or scan the QR code below.



This provides information about possible combinations with S2060. (Some products are not sold in all markets).

Delivery and handling

Transport

S2060 should be transported and stored vertically in a dry place.



CAUTION!

Ensure that the heat pump cannot fall over during transport.

Check that S2060 has not been damaged during transport.

LIFT FROM THE STREET TO THE SET UP LOCATION

If the surface allows, the easiest method is to use a pallet truck to move the heat pump to the installation area.

The centre of gravity is offset to one side (see print on the packaging).

If the heat pump needs to be transported across soft ground, such as a lawn, we recommend using a crane truck that can lift it to the installation location. When the heat pump is lifted with a crane, the packaging must be intact.

If a crane truck cannot be used, the heat pump can be transported on an extended sack truck. The heat pump must be taken hold of from its heaviest side and two people are required to lift it.

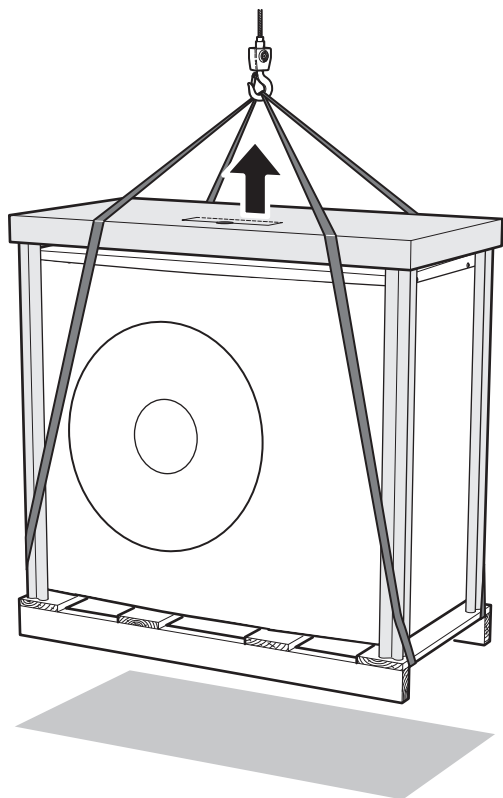

LIFT FROM THE PALLET TO FINAL POSITIONING

1. Remove the packaging.
2. Dismantle the load anchor to the pallet.
3. Pull lifting straps through the holes in the stand. We recommend that two people perform the lift from the pallet to the base. The fan grille should not be installed when lifting.

SCRAPPING

When scrapping, remove the heat pump in reverse order. In this case, lift by the base plate rather than the pallet.

Assembly

- Place the heat pump in a suitable location outdoors to prevent any risk of the refrigerant flowing in through ventilation openings, doors or similar openings in the event of a leak. It must also not constitute a hazard to people or property in any other way.
- If the heat pump is placed in a location where any refrigerant leak could accumulate, for example below ground level (in a dip or low-lying recess), the installation must satisfy the same requirements that apply for gas detection and the ventilation of engineering rooms. Requirements regarding sources of ignition must be applied where appropriate.
- Place S2060 outdoors on a solid level base that can take the weight, preferably a concrete foundation. If concrete slabs are used they must rest on asphalt or shingle.
- S2060 should not be positioned next to noise sensitive walls, for example, next to a bedroom.
- Also ensure that the placement does not inconvenience the neighbours.
- S2060 must not be placed so that recirculation of the outdoor air is possible. Recirculation entails reduced power and impaired efficiency.
- The evaporator must be sheltered from direct wind / , which negatively affects the defrosting function. Place S2060 protected from wind / against the evaporator.
- Do not install S2060 in locations where there might be substances in the atmosphere that might affect the unit, such as sulphide gas, chlorine, acid or alkaline substances, very salty air.
- Do not install S2060 in locations where powder may be present in the air, such as carbon fibre, metal powder.
- Large amounts of condensation, as well as melt water from defrosting, may be produced. Condensation must be led off to a drain or similar (see section "Condensation water").

- If there is a risk of snow slip from roof, a protective roof or cover must be erected to protect the heat pump, pipes and wiring.

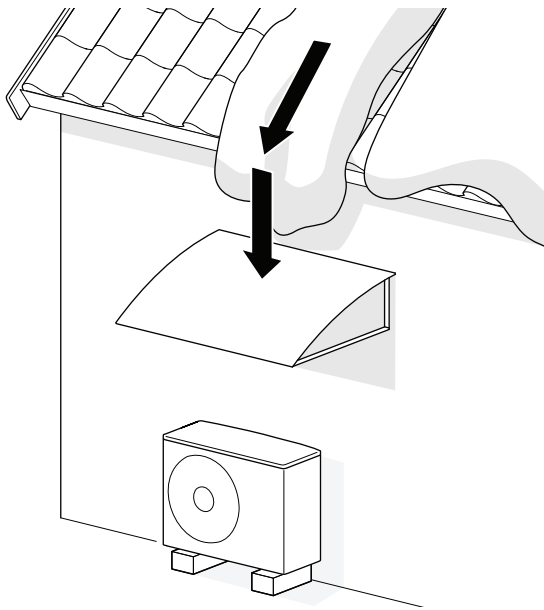

INSTALLATION AREA

Leave a free space of at least 200 mm between S2060 and the house wall, but not more than 500 mm in windy locations.

Leave a free space of 1,000 mm in front of, and 1,000 mm above, the product.

Approx. 500 mm free space is needed on the right-hand side to allow the front panel to be removed.

The lower edge of the evaporator must not be lower than the level of the average local snow depth, or at least 300 mm above ground level. The base should be at least 70 mm tall.

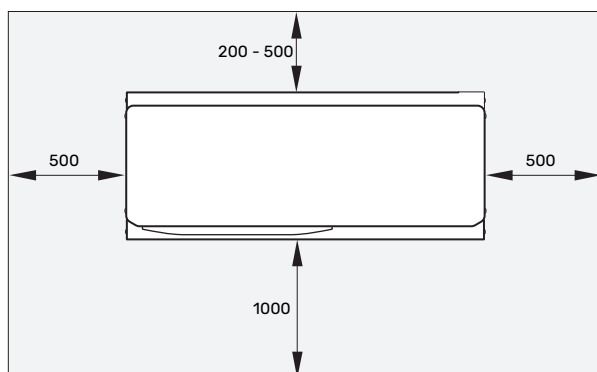

Condensation

The condensate drain pan collects and leads away the condensation water.



CAUTION!

It is important to the heat pump function that condensation water is led away and that the drain for the condensation water run off is not positioned so that it can cause damage to the house.

Pipe with heating cable (KVR), for draining the condensate drip tray, is not included. To guarantee this function, the accessory KVR should be used.

- The condensation water (up to 50 litres / 24 hrs) must be routed away by a pipe to an appropriate drain, it is recommended that the shortest outdoor length possible is used.
- The section of the pipe that can be affected by frost must be heated by the heating cable to prevent freezing.
- Route the pipe downward from the heat pump.
- The outlet of the condensation water pipe must be at frost free depth.
- Use a water trap for installations where air circulation may occur in the condensation water pipe.
- The insulation must seal against the bottom of the condensation water trough.

CONDENSATE DRIP TRAY HEATER, CONTROL

The condensate drip tray heater starts when the following conditions are met:

1. The operating mode is "Heating".
2. The compressor is operational.
3. The ambient temperature is lower than 0 °C.

DRAINAGE OF CONDENSATION



NOTE!

If none of the following recommended alternatives is used, good drainage of condensation must be provided.

Stone caisson

If the house has a cellar the stone caisson must be positioned so that condensation water does not affect the house. Otherwise, the stone caisson can be positioned directly below the heat pump.

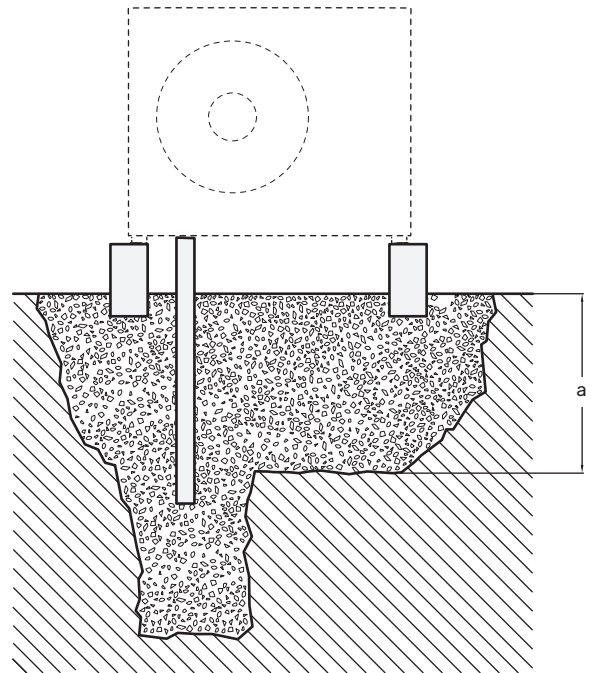

a = Frost-free depth

Gutter drainage

Route the pipe sloping down from the heat pump. The condensation water pipe must have a water seal to prevent air circulation in the pipe.

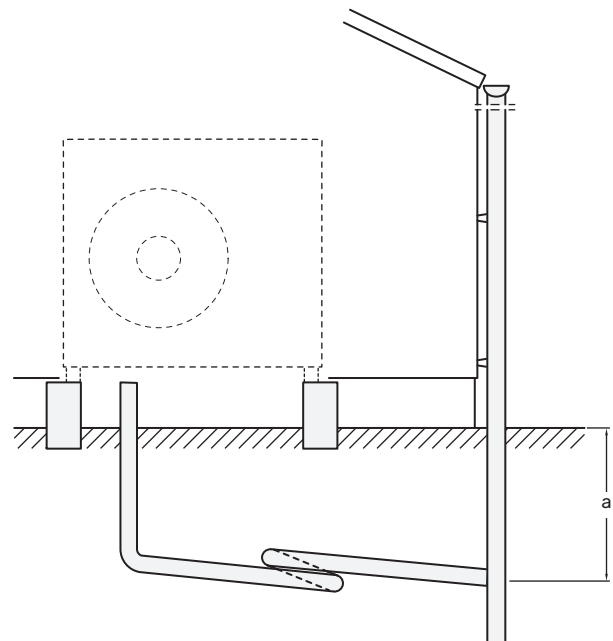

a = Frost-free depth

Supplied components

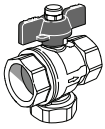

Filterball (G1") (QZ2)

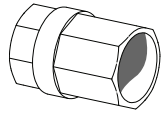

Non-return valve (RM1)

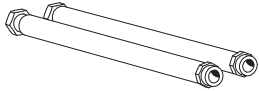

Flexible hoses (WN3) (2 pcs)
(Dimensions, flexible pipes
DN25, G1")

Gaskets (4 pcs)

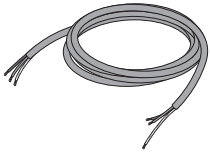

Power supply cable (W1)

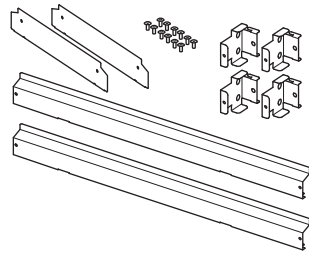

Plinth

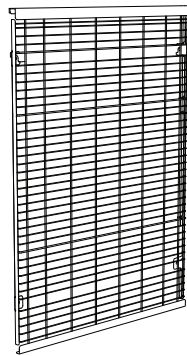

Fan grille
Screws (4 pcs)

Installing the enclosed plinth

1. Install the four spacer brackets, one in each corner.

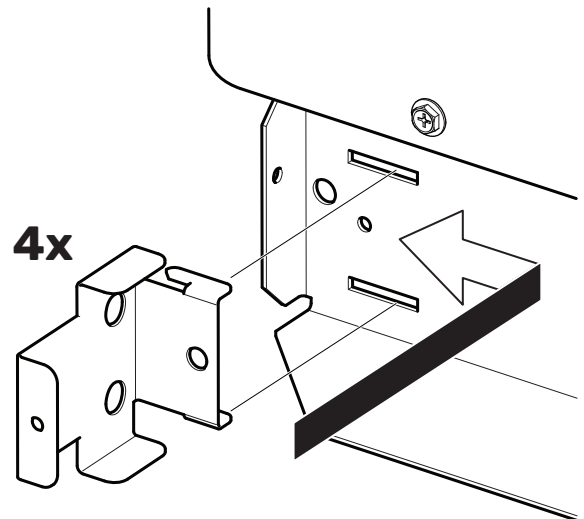

2. Attach with the enclosed screws.

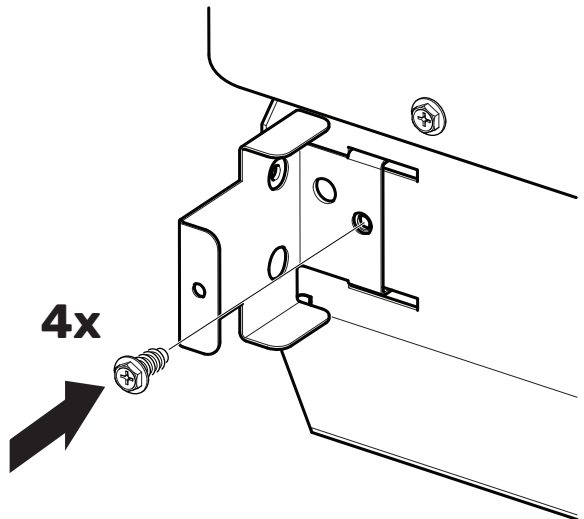

3. Install the four skirting boards and attach with the enclosed screws.

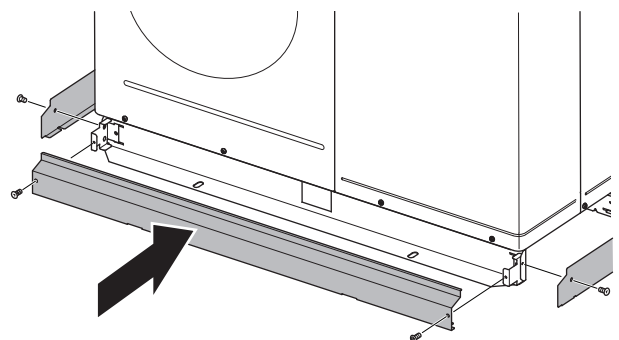

Handling panels

REMOVING THE SIDE PANEL

1. Loosen all screws.
2. Remove the side panel by first sliding the panel down and then outwards.

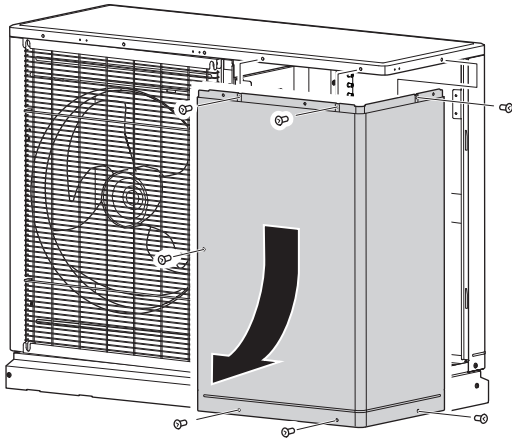

Dismantling cardboard box

Remove the pieces of cardboard found inside.

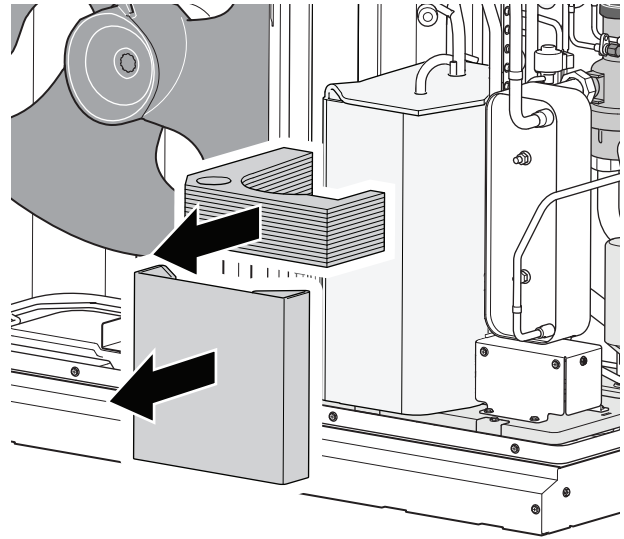

DISMANTLING TOP PANEL

1. Remove the fan grille, if fitted. See section "Installing the enclosed fan grille".
2. Loosen the top panel's screws.
3. Lift off the top panel.

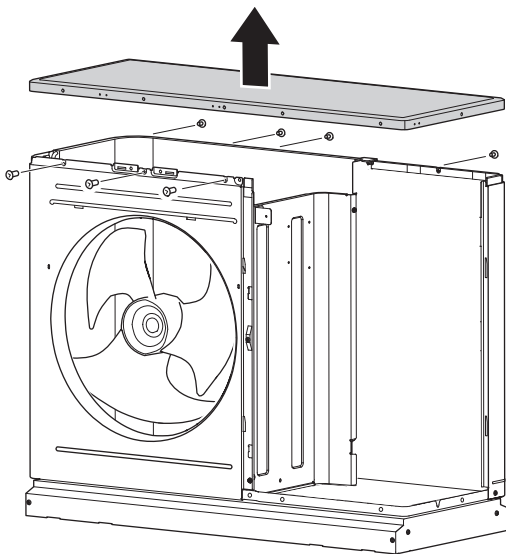

Removing the transport safety devices

Disconnect the two transport safety devices that are fitted between the bottom panel and the compressor plate.

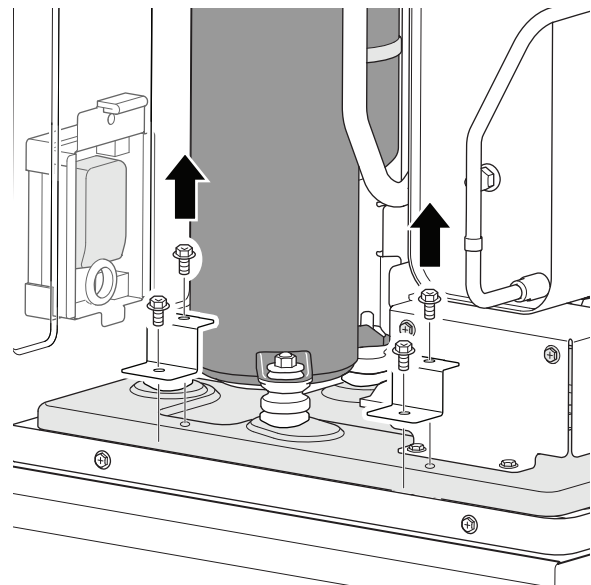

Installing the enclosed fan grille

1. Secure the fan grille with the four enclosed screws.

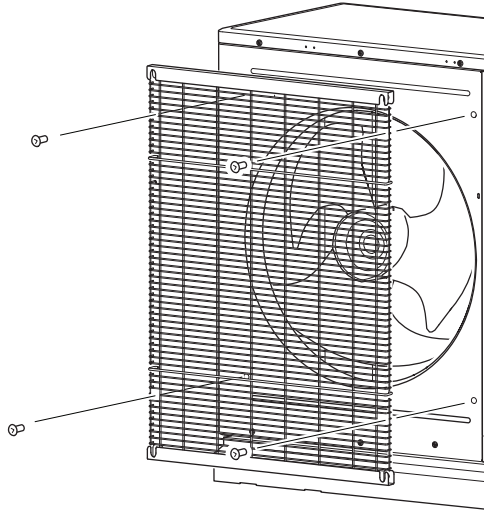

2. Removal is performed in the reverse order.

The heat pump design

General

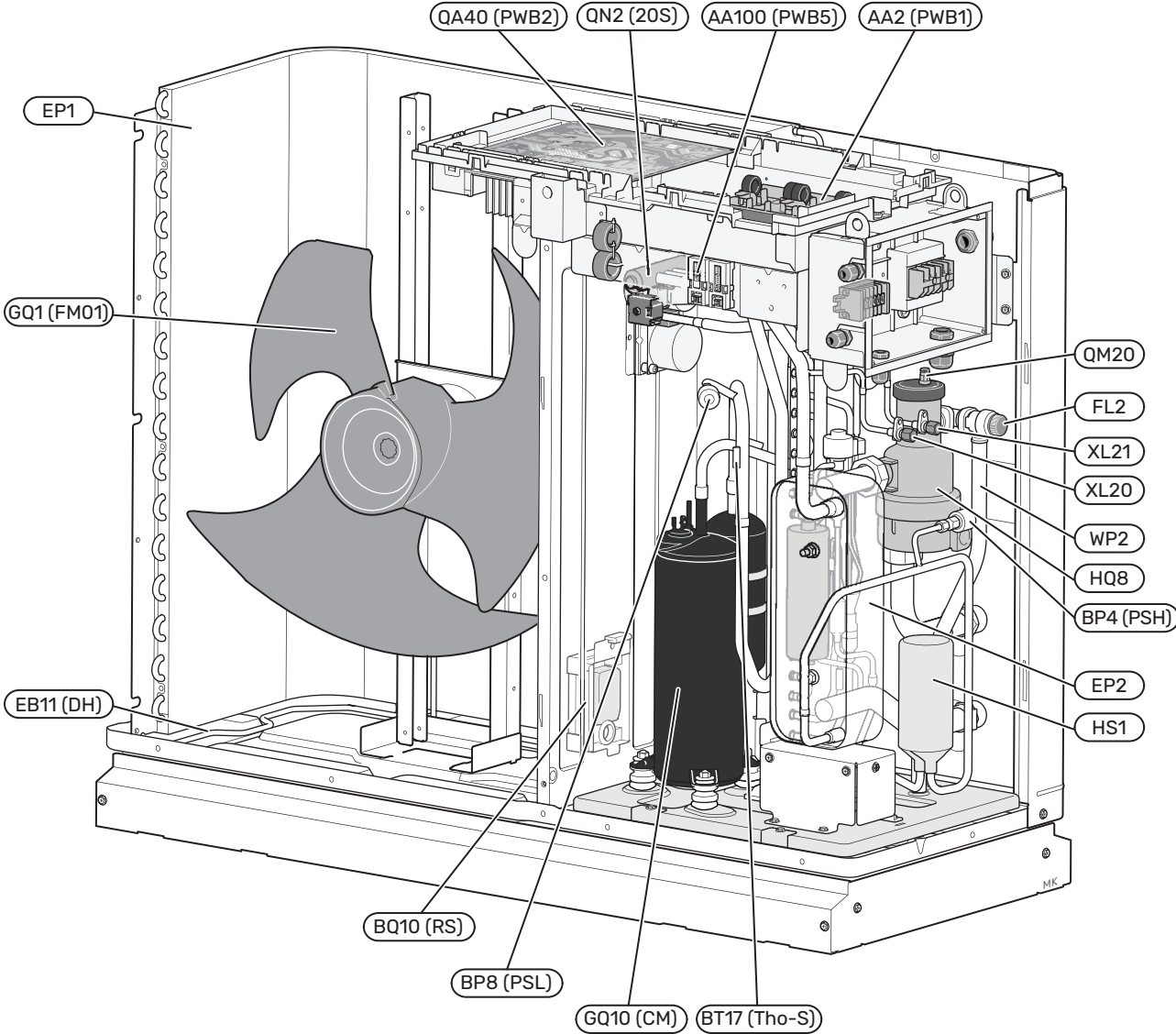

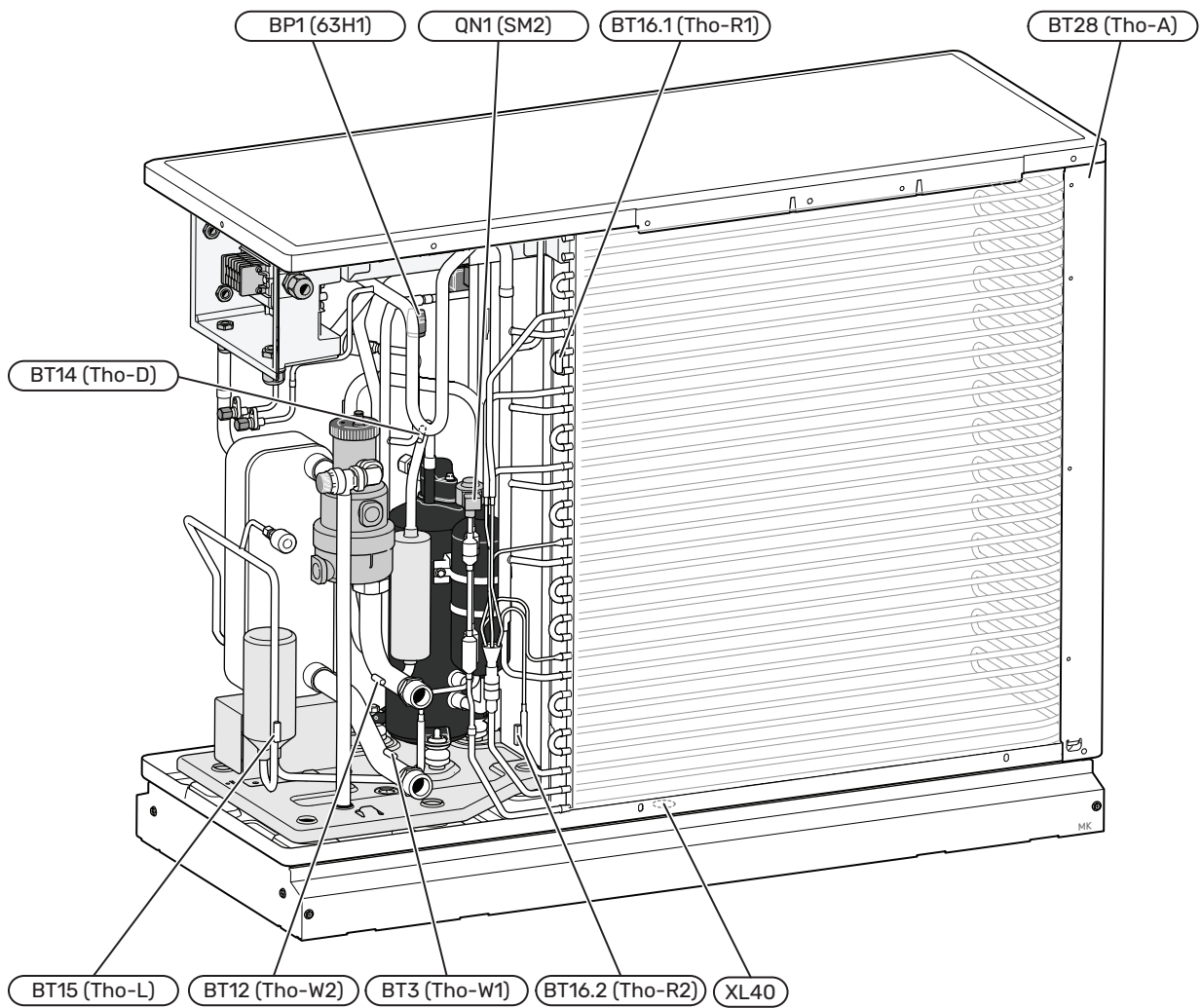

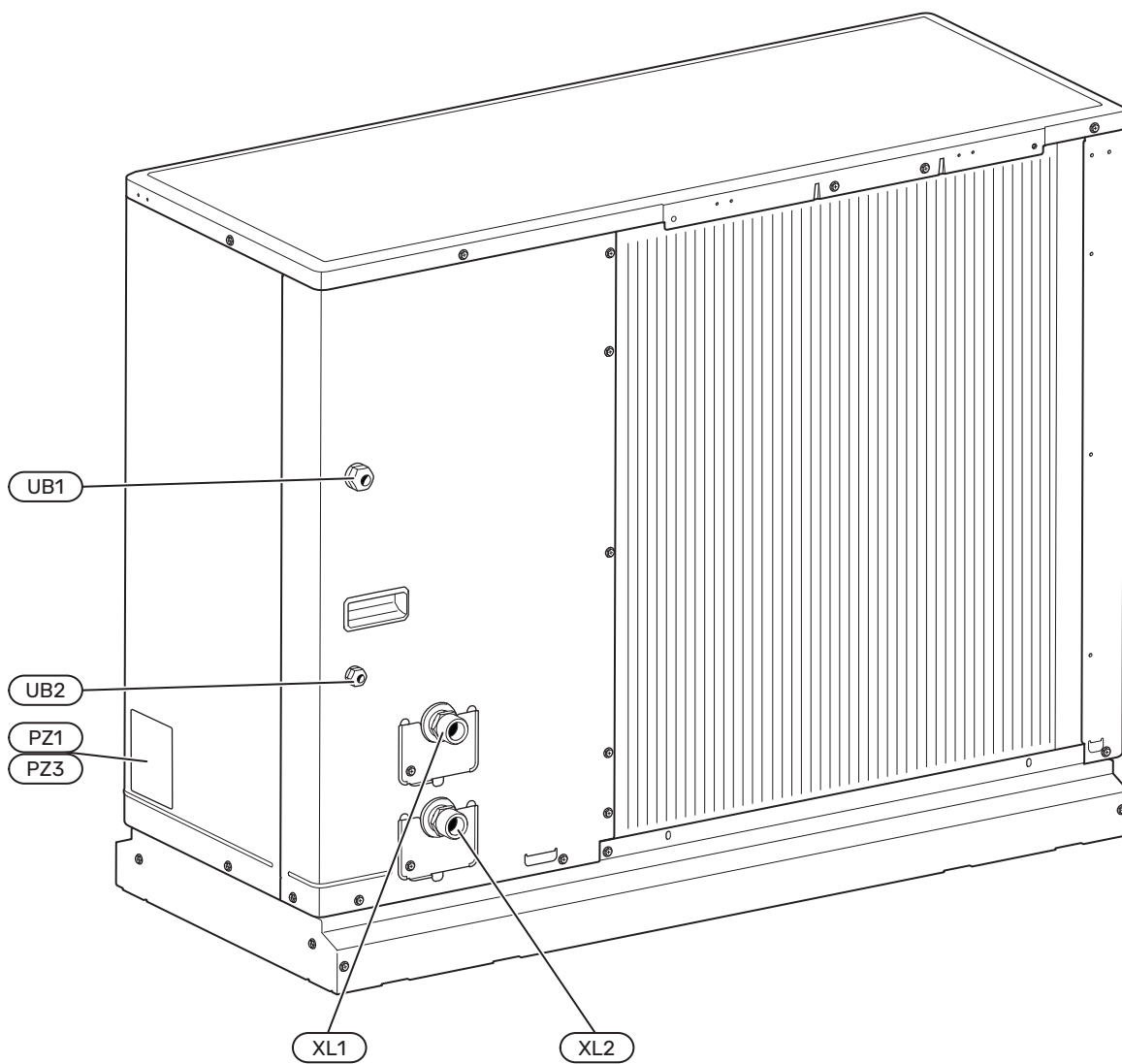

Pipe connections

XL1	Heating medium connection, supply (out from S2060)
XL2	Heating medium connection, return (to S2060)
XL20	Service connection, high pressure
XL21	Service connection, low pressure
XL40	Condensation drain connection

HVAC components

FL2	Safety valve, climate system
HQ8	Automatic gas separator
QM20	Vent valve, heating medium
WP2	Overflow pipe from safety valve for heating medium

Sensors etc.

BP1 (63H1)	High pressure switch
BP4 (PSH)	High pressure sensor
BP8 (PSL)	Low-pressure sensor
BQ10 (RS)	Refrigerant sensor
BT3 (Tho-W1)	Return line sensor
BT12 (Tho-W2)	Condenser sensor, supply line
BT14 (Tho-D)	Hot gas sensor
BT15 (Tho-L)	Fluid line sensor
BT16.1 (Tho-R1)	Evaporator sensor 1
BT16.2 (Tho-R2)	Evaporator sensor 2
BT17 (Tho-S)	Suction gas sensor
BT28 (Tho-A)	Ambient sensor

Electrical components

EB11 (DH)	Condensation water trough heater
GQ1 (FM01)	Fan
AA2 (PWB1)	Base card
QA40 (PWB2)	Inverter board
AA100 (PWB5)	Joint card

Cooling components

EP1	Evaporator
EP2	Condenser
GQ10 (CM)	Compressor
HS1	Drying filter
QN1 (SM2)	Expansion valve, heating and cooling
QN2 (20S)	Reversing valve

Miscellaneous

PZ1	Rating plate
PZ3	Serial number plate
UB1	Cable gland, incoming supply
UB2	Cable grommet, communication

Designations according to standard EN 81346-2.

Designations within brackets according to the supplier's standard.

Pipe connections

General

Pipe installation must be carried out in accordance with current norms and directives.

S2060 is not equipped with shut-off valves on the heating medium side, rather these must be installed to facilitate any future servicing.

MINIMUM SYSTEM FLOW DEFROSTING

CAUTION!
An undersized climate system can result in damage to the product and lead to malfunctions.

The dimensions of the pipes between the indoor module and the heat pump should not be less than the recommended pipe diameter. However, each climate system must be dimensioned individually to provide the recommended system flows.

The installation must be dimensioned to provide the minimum defrosting flow at 100 % circulation pump operation.

Air/water heat pump	Minimum flow during defrosting 100% circulation pump operation (l/s)	Minimum recommended pipe dimension (DN)	Minimum recommended pipe dimension (mm)
S2060-6	0.14	20	22
S2060-10	0.21	20	22

WATER VOLUMES

To prevent short operating times, and to enable defrosting, a certain available water volume is required. For the optimum operation of S2060, a minimum available water volume is recommended, see table. This applies separately to heating and cooling systems.

Following water volumes are recommended

S2060	6	10
Minimum volume, climate system during heating/cooling	50 l	80 l
Minimum volume, climate system during under floor cooling	80 l	80 l

CAUTION!
The pipe installation must be flushed out before the heat pump is connected so debris cannot damage component parts.

SYSTEM DIAGRAM

Principle of operation with indoor module, hot water and climate system.

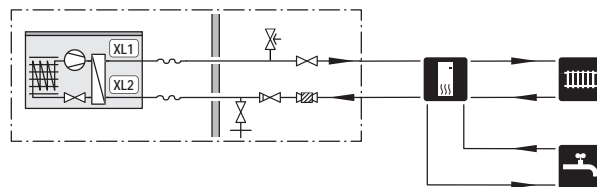

- XL1 Heating medium connection, supply (out from S2060)
- XL2 Heating medium connection, return (to S2060)

Symbol key

Symbol	Meaning
	Shut-off valve
	Tapping valve
	Non-return valve
	Circulation pump
	Expansion vessel
	Filterball
	Pressure gauge
	Safety valve
	Diverter valve/shunt
	Air/water heat pump
	Control module
	Domestic hot water
	Water heater
	Heating system

Pipe coupling heating medium circuit



CAUTION!

Do not add any antifreeze, such as glycol, to the hydraulic system as this will affect the operation of the internal safety devices. Instead, install anti-freeze valves in the system, close to the heat pump.



NOTE!

There is a difference between connection to a control module compared with connection to an indoor module.

See the Installer Manual for the indoor module/control module.

Install as follows:

- expansion vessel
- pressure gauge
- pressure relief valve
- non-return valve

Installations with only one heat pump: a non-return valve is only required in those cases where the placement of the products in relation to each other can cause self-circulation.

Cascade installations: each heat pump must be fitted with a non-return valve.

- charge pump
- shut-off valve

To facilitate any future servicing.

- enclosed filterball (QZ2)

The filterball must be installed indoors on the return line to the heat pump.

- diverter valve.

When connecting to the control module, and if the system is to be able to work with both the climate system and the hot water heater.

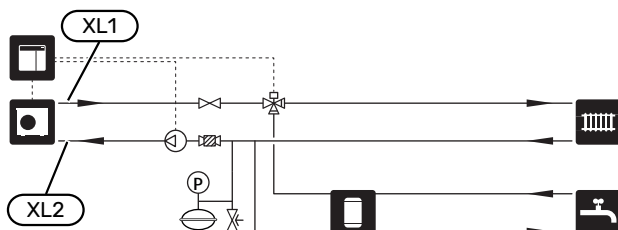

The image shows connection to the control module.

PIPE CONNECTIONS FLEX HOSE

All outdoor pipes must be insulated with at least 19 mm thick pipe insulation.¹

The supplied flexible hoses act as vibration dampers. The flexible pipes are fitted so an elbow is created, thus acting as vibration damping.

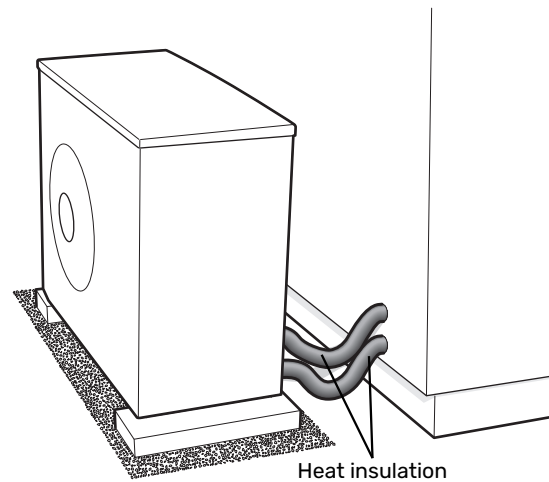

¹ Alternatively in accordance with country-specific requirements.

Electrical connections

General

- Electrical installation and wiring must be carried out in accordance with national provisions.
- Prior to insulation testing the house wiring, disconnect the air/water heat pump installation.
- If a miniature circuit breaker is used, this must have at least triggering characteristic "C". See section "Technical specifications" for fuse size.
- S2060 must be installed via an isolator switch. The cable area has to be dimensioned based on the fuse rating used.
- S2060 must be fitted with a RCD (residual current device). A separate residual current device is recommended.
- The residual current device must have a nominal tripping current not exceeding 30 mA and must be of the type F or B.
- The communication cable must be a screened cable with three conductors.
- To prevent interference, communication cables to external connections must not be laid in the vicinity of high voltage cables.
- Connect the charge pump to the control module. See where the charge pump is to be connected in the Installer Manual for your control module.
- When routing a cable into S2060, the cable grommets (UB1) and (UB2) must be used.

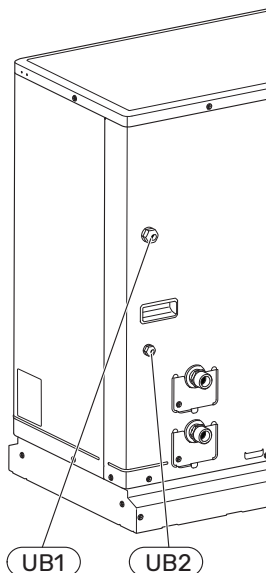

CAUTION!

Electrical installation and any servicing must be carried out under the supervision of a qualified electrician. Turn off the power with the circuit breaker before servicing.



CAUTION!

Check the connections, main voltage and phase voltage before the product is started, to prevent damage to the heat pump electronics.



CAUTION!

The live external control must be taken into consideration when connecting.



CAUTION!

If the supply cable is damaged, only NIBE, its service representative or similar authorised person may replace it to prevent any danger and damage.



CAUTION!

Do not start the system before filling up with water. Components in the system could be damaged.

Accessibility, electrical connection

See section "Handling panels".

Connections

TERMINAL BLOCKS ETC.

The following components are used.

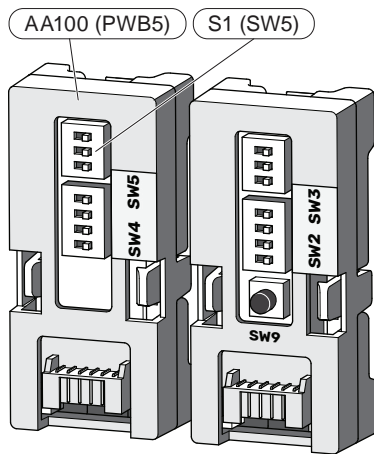
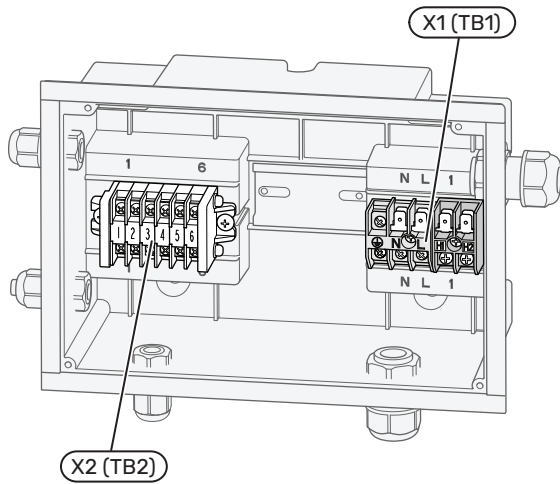

POWER CONNECTION

Supply voltage

Connect the enclosed power cable (W1) to terminal block X1 (TB1).

Tightening torque 1 Nm.

1x230 V

X1 (TB1)

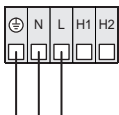

COMMUNICATION

For connection of indoor module / control module, see relevant manual on nibe.eu.

Cable routing, communication

Connect the communication cable to the terminal block for communication (X2 (TB2): 1-3) in S2060.

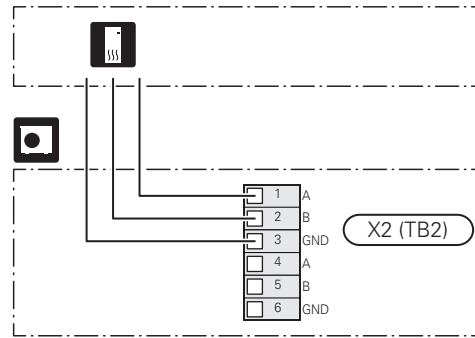

Cascade connection

Connect terminal block -X2 (TB2): 4-6 with the next heat pump's terminal block -X2 (TB2): 1-3 for cascade connection.

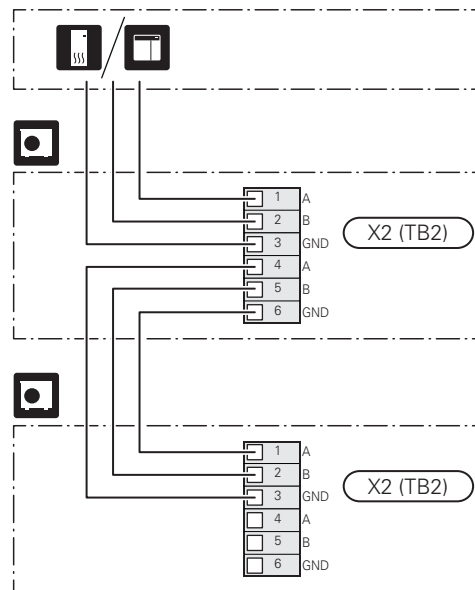

DIP switch

S2060 is equipped with a DIP switch (S1 (SW5)) on the joint board (AA100 (PWB5)).



CAUTION!

Only change the DIP switch when S2060 is not powered up.

Cascade connection

In installations with multiple heat pumps, each heat pump must have a unique address, which is set with the DIP switch.

Heat pump	Position (1 / 2 / 3)
1 (EB101)	off / off / off
2 (EB102)	on / off / off
3 (EB103)	off / on / off
4 (EB104)	on / on / off
5 (EB105)	off / off / on
6 (EB106)	on / off / on
7 (EB107)	off / on / on
8 (EB108)	on / on / on

Commissioning and adjusting

Filling

Fill the heating system with water to the required pressure. The heat pump is equipped with an automatic vent valve for heating medium (QM20), which closes when the heat pump is filled with liquid.

Venting

1. The heat pump is vented automatically using the vent valve for heating medium (QM20), which is located on the gas separator (HQ8). The vent valve closes automatically when the valve housing has been vented and filled with liquid.
2. Vent the circulation pump, if present.
3. Keep topping up and venting until all air has been removed and the pressure is correct.

Commissioning



CAUTION!

Do not start S2060 if there is a risk that the water in the system has frozen.



CAUTION!

Do not start any electrical work until at least two minutes after cutting the power.

1. Check that the communication cable between S2060 and the indoor module/control module is connected.
2. Power-up S2060 and the indoor module/control module.
3. Adjust the charge flow according to size. See also section "Adjustment, charge flow".
4. Follow the instructions in the start guide in the indoor module's/control module's display.
5. Fill in "Inspection of the installation", in section "Important information".

The live external control must be taken into consideration when connecting.

Adjustment, charge flow

For correct function of the heat pump over the entire year, the charge flow must be correctly adjusted.

If an NIBE indoor module or accessory-controlled charge pump is used for the control module, the control tries to maintain an optimal flow across the heat pump.

Adjustment may be required, especially for charging a separate water heater. It is therefore recommended to have the option of adjusting the flow across the water heater using a trim valve.

1. Recommendation if there is insufficient hot water and information message "high condenser out" during hot water charging: increase the flow
2. Recommendation if there is insufficient hot water and information message "high condenser in" during hot water charging: reduce the flow

Charge pump

The charge pump (not included in the product) is powered and controlled from the indoor module/control module. It has a built-in frost protection function and, for this reason, must not be switched off when there is a risk of freezing.

At outdoor temperatures below +2 °C, the charge pump runs periodically, to prevent the water from freezing in the charge circuit. The function also protects against excess temperatures in the charge circuit.

Pressure drop, heating medium side

Pressure drop (kPa)

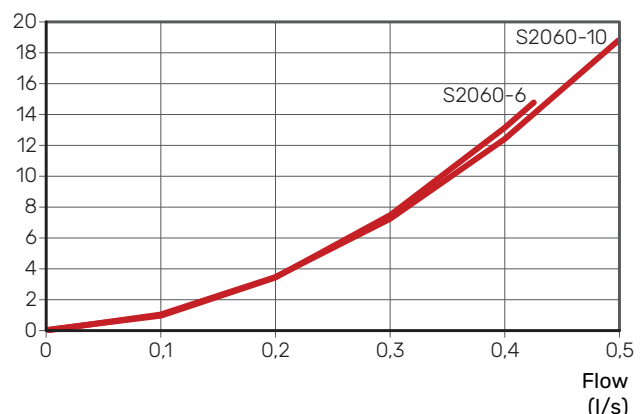

Control

General

S2060 is equipped with an internal electronic controller that handles all the functions necessary for operating the heat pump, e. g. defrosting, stop at max/min temperature and protective functions during operation.

The integrated control shows information via status-LEDs and can be used during servicing.

Under normal operating conditions the home owner does not need to have access to the controller.

S2060 communicates with the NIBE indoor module/control module, which means that all settings and measurement values from S2060 are adjusted and read off on the indoor module/control module.



NOTE!

The main product's software must be the latest version.

Activating S2060

S-SERIES

Settings for S2060 can be made via the start guide or directly in the menu system.

The main product's software must be the latest version.

Start guide

The start guide appears upon first start-up after heat pump installation, but is also found in menu 7.7.

Menu system

If you do not make all settings via the "Start guide", or if you need to change any of the settings, you can do this in the menu system.

Menu 7.3.2 - Installed heat pump

Here, you make specific settings for the installed heat pump.

Menu 7.3.2.1 - Heat pump settings

Here, you make settings that are specific for the installed heat pumps.

Cooling permitted

Alternative: on/off

Silent mode permitted

Alternative: on/off

Max. frequency 1

Setting range: 25 Hz -

The setting range depends on the outdoor unit's size and sound requirements.

Max. frequency 2

Setting range: 25 Hz -

The setting range depends on the outdoor unit's size and sound requirements.

Compressor phase

Setting range S2060 1 x 230 V: L1, L2, L3

Detect compressor phase

Alternative S2060 1 x 230 V: on/off

Current limit

Alternative S2060 1 x 230 V: on/off

Max. current

Setting range S2060 1 x 230 V: 6 - 32 A

Stop temperature compressor

Setting range -25 - -2 °C

BlockFreq 1 and 2

Setting range, heating: 25 - 130 Hz

Setting range, cooling: 25 - 120 Hz

Silent mode permitted: Here, you set whether silent mode will be activated for the heat pump. Note, it is now possible to schedule when silent mode will be active. The function should only be used for limited periods, because S2060 might not reach its dimensioned power.

Detect compressor phase: This shows in which phase the heat pump detected that you have S2060 1x230 V. Phase detection normally occurs automatically in connection with start-up of the indoor module/control module. This setting can be changed manually.

Current limitation: Here, you set whether the current limitation function will be activated for the outdoor unit, if you have S2060 1x230 V. During active function, you can limit the value of the maximum current.

BlockFreq 1-2: Here, you can select the frequency ranges within which the outdoor unit is not permitted to work. This function can be used if certain compressor speeds cause disruptive noise in the house. The setting range varies depending on heat pump model and size.

Cooling permitted: Here, you can set whether the cooling function will be activated for the heat pump.

F-SERIES

Settings for S2060 can be made via the start guide or directly in the menu system.

The main product's software must be the latest version.

Start guide

The start guide appears upon first start-up after heat pump installation, but is also found in menu 5.7.

Menu system

If you do not make all settings via the "Start guide", or if you need to change any of the settings, you can do this in the menu system.

Menu 5.11.1.1 - heat pump

Here, you make specific settings for the installed heat pump.

Cooling permitted

Setting range: off / on

Silent mode permitted

Setting range: yes / no

Detect compressor phase

Setting range S2060 1 x 230 V: off/on

Current limit

Setting range: 6 – 32 A

Factory setting: 32 A

blockFreq 1

Setting range: yes / no

blockFreq 2

Setting range: yes / no

Cooling permitted: Here, you can set whether the cooling function will be activated for the heat pump.

Silent mode permitted: Here, you set whether silent mode will be activated for the heat pump. Please note that you now have the option to schedule when silent mode will be active.

The function should only be used for limited periods, because S2060 possibly may not reach its dimensioned output.

Detect compressor phase: This shows in which phase the heat pump detected that you have S2060 1x230 V. Phase detection normally occurs automatically in connection with start-up of the indoor module/control module. This setting can be changed manually.

Current limitation: Here, you set whether the current limiting function is to be activated for the heat pump, if you have S2060 1x230 V. During active function, you can limit the value of the maximum current.

BlockFreq 1: Here, you can select a frequency range within which the heat pump is not permitted to work. This function can be used if certain compressor speeds cause disturbing noise in the house.

BlockFreq 2: Here, you can select a frequency range within which the heat pump is not permitted to work.

Service

Service actions



CAUTION!

Servicing should only be carried out by persons with the necessary expertise.

When replacing components on S2060 only replacement parts from NIBE may be used.

DRAINING THE CONDENSER

In the event of a prolonged power failure or similar, for example, the condenser in S2060 may need to be drained of water.



CAUTION!

There may be some hot water, risk of scalding.

1. Close the shut-off valves.
2. Disconnect the two heating medium connection pipes, the heating medium connection, supply (XL1) and heating medium connection, return (XL2).
3. Empty out the water, drain via the non-return valve (RM1).

TEMPERATURE SENSOR DATA

Return line sensor (BT3 (Tho-W1)), condenser sensor supply line (BT12 (Tho-W2)), liquid line sensor (BT15 (Tho-L)), evaporator sensors (BT16.1 (Tho-R1)) and (BT16.2 (Tho-R2)), suction gas sensor (BT17 (Tho-S))

Temperature (°C)	Resistance (kOhm)
0	15.0
5	12.5
10	10.0
15	8.0
20	6.2
25	5.0
30	4.0
35	3.2
40	2.6
45	2.1
50	1.7

Discharge sensor (BT14 (Tho-D))

Temperature (°C)	Resistance (kOhm)
0	180
10	110
20	65
30	45
40	32
50	24
60	18
70	14
80	11
90	9
100	7
120	5
140	4
160	3

Ambient sensor (BT28 (Tho-A))

Data for cold temperature sensors, for example the outdoor temperature sensor (BT28).

Temperature (°C)	Resistance (kOhm)
-20	50
-10	45
0	32.7
5	27
10	22
15	18
20	14
25	11
30	9
35	7
40	6
45	5
50	4

REPLACEMENT OF REFRIGERANT SENSOR

After 15 years, the refrigerant sensor (BQ10 (RS)) must be replaced. An alarm in the indoor module/control modules will indicate when it is time.

Disturbances in comfort

In most cases, the indoor module / control module notes a malfunction and indicates this with alarms and presents action instructions in the display.

Troubleshooting



CAUTION!

In the event of action to rectify malfunctions that require work within screwed hatches, the incoming supply electricity must be isolated at the safety switch by or under the supervision of a qualified electrician.



NOTE!

Alarms are acknowledged on the indoor module / control module.

If the operational interference is not shown in the display the following tips can be used:

BASIC ACTIONS

Start by checking the following:

- All supply cables to the heat pump are connected.
- Group and main fuses of the accommodation.
- The property's earth circuit breaker.
- The heat pump's RCD.
- The heat pump's fuse / automatic protection. (FC1 / FB1, FB1 only if KVR is installed.)
- The indoor module's/control module's fuses.
- The indoor module's temperature limiter.
- That the air flow to S2060 is not blocked by foreign objects.
- That S2060 does not have any external damage.

S2060 DOES NOT START

- There is no demand.
 - The indoor module/control module does not call on heating, cooling or hot water.
- Compressor blocked due to the temperature conditions.
 - Wait until the temperature is within the product's working range.
- Minimum time between compressor starts has not been reached.
 - Wait for at least 30 minutes and then check if the compressor has started.
- Alarm tripped.
 - Follow the display instructions.

S2060 NOT COMMUNICATING

- Check that the addressing of S2060 is correct.
- Check that the communication cable is correctly connected and working.

LOW HOT WATER TEMPERATURE OR A LACK OF HOT WATER

This part of the troubleshooting chapter only applies if the heat pump is docked to the hot water heater or indoor module.

- Large hot water consumption.
 - Wait until the hot water has heated up.
- Incorrect hot water settings in indoor module/control module.
 - See the Installer Manual for the indoor module/control module.
- Clogged filterball.
 - Switch off the system. Check and clean the filterball.

LOW ROOM TEMPERATURE

- Closed thermostats in several rooms.
 - Set the thermostats to max in as many rooms as possible.
- Incorrect settings in the indoor module/control module.
 - See the Installer Manual for the indoor module/control module.
- Air-filled radiators/underfloor heating coils.
 - Bleed the system.

HIGH ROOM TEMPERATURE

- Incorrect settings in the indoor module/control module.
 - See the Installer Manual for the indoor module/control module.

LARGE AMOUNT OF WATER BELOW S2060

- The accessory KVR is required.
- If KVR is installed, check that the water drainage can flow freely.

Alarm list

Alarm F-series	Alarms S-series	Alarm text on the display	Description existing alarm	May be due to
162	215	High temperature condenser supply (BT12)	The supply temperature (BT12) out of the condenser is above the maximum temperature.	Low flow during heating operation. Temperatures set too high.
163	216	High condenser temperature in	The return temperature (BT3) into the condenser is above the maximum temperature.	Temperature generated by another heat source.
183	221	Defrost	The heat pump is defrosting (status alarm).	Activated when the heat pump runs its defrosting procedure.
217	227	The fuse in the heat pump has tripped	When the inverter's fuse has tripped.	Current too high.
218	228	The compressor's rotor is blocked	The rotor is locked.	Compressor fault. Startup fault. Overheating.
220	229	High pressure alarm	When the high pressure switch (BP1 (63H1)) has tripped 5 times within 60 minutes.	Insufficient air circulation or blocked heat exchanger. Open-circuit or short-circuit on input for high pressure switch (BP1 (63H1)). Defective high pressure switch (BP1 (63H1)). Incorrectly connected expansion valve. Service valve closed. Defective base board (AA2 (PWB1)) in S2060. Low or no flow during heating operation. Defective circulation pump. Defective fuse, F (4A).
221	230	Low pressure alarm	When the low-pressure sensor (BP8 (PSL)) detects abnormally low pressure.	Open circuit or short circuit on input for low-pressure sensor. Defective low-pressure sensor (BP8 (LPT)). Defective base board (AA2 (PWB1)) in S2060. Open-circuit or short-circuit on input for suction gas sensor (BT17 (Tho-S)). Defective suction gas sensor (BT17 (Tho-S)). Lack of refrigerant.
224	233	Fan alarm in outd air heat pump	No feedback signal from the fan 5 times within 240 minutes.	Fan blocked or not connected. Defective or dirty base board (AA2 (PWB1)) in S2060. Defective fan motor. Tripped fuse (F2).
228	236	Defrosting fault	10 failed consecutive defrostings.	System temperature and/or flow too low. Insufficient available system volume. Poor air flow, for example, due to leaves, snow, ice or strong wind effect.
230	238	High discharge	High temperature on discharge sensor (BT14). If the above state occurs 2 times within 60 minutes, or if the temperature is kept at 115 °C or higher for 60 minutes or longer.	Disruption in the refrigerant circuit. Lack of refrigerant. The discharge sensor (BT14) has reached a temperature of 115 °C

Alarm F-series	Alarms S-series	Alarm text on the display	Description existing alarm	May be due to
261	251	High HWX temp	High pressure and/or temperature in the evaporator.	Sensor does not work. Insufficient air circulation or blocked heat exchanger. Defective control board. Too much refrigerant.
262	252	Power transistor too hot	To avoid damage if the current is too high.	Interference on the incoming power supply. Service valve closed. Insufficient amount of refrigerant. Compressor fault. Defective inverter board (QA40 (PWB2)).
263	253	The inverter has detected an abnormally high current	The inverter has detected an abnormally high current.	If communication faults occur between inverter and control unit.
264	254	Communication fault to inverter	The communication between the circuit board for the inverter and the base board is interrupted.	Poor connection between PCB and inverter. Inverter unpowered or broken. Defective base board (AA2 (PWB1)) in S2060.
265	255	Inverter PCB fault	The power transistor emits a fault signal.	Defective fan motor Defective inverter board (QA40 (PWB2)).
267	257	Failed compressor start	The compressor failed to start.	Defective inverter board (QA40 (PWB2)). Defective base board (AA2 (PWB1)) in S2060. Compressor fault.
268	258	Overcurrent	Overcurrent in the inverter.	Sudden power failure.
272	261	Warm outd air, heat. mode	The outside temperature is too high to ensure safe operation.	Warm weather conditions. Sensor fault.
271	260	Cold outd air, heat. mode	The outside temperature is too low to ensure safe operation.	Cold weather conditions. Sensor fault.
277	147	Sens flt from heat pump	In the case of repeated sensor disconnection, evaporator sensor (BT16).	Open-circuit or short-circuit on sensor input. Defective base board (AA2 (PWB1)) in S2060.
278	148	Sens flt from heat pump	In the case of repeated sensor disconnection, ambient sensor (BT28).	Open-circuit or short-circuit on sensor input. Defective base board (AA2 (PWB1)) in S2060.
279	149	Sens flt from heat pump	In the case of repeated sensor disconnection, discharge sensor (BT14).	Open-circuit or short-circuit on sensor input. Defective base board (AA2 (PWB1)) in S2060.
280	150	Sens flt from heat pump	In the case of repeated sensor failures, suction gas sensor (BT17).	Open-circuit or short-circuit on sensor input. Defective base board (AA2 (PWB1)) in S2060.
281	151	Sens flt from heat pump	In the case of repeated sensor failures, low-pressure sensor (BP8 (PSL)), high-pressure sensor (BP4 (PSH)).	Open circuit or short circuit on sensor input. Defective base board (AA2 (PWB1)) in S2060. Fault in the refrigerant circuit.
285	243	Refrigerant sensor fault	Refrigerant sensor (BQ10 (RS)) is either out of range, has lost communication or is faulty.	Fault in the sensor.
286	245	Refrigerant sensor needs to be replaced	Refrigerant sensor (BQ10 (RS)) in the heat pump needs to be replaced.	Refrigerant sensor (BQ10 (RS)) is 15 years old or more.

Alarm F-series	Alarms S-series	Alarm text on the display	Description existing alarm	May be due to
287	248	Refrigerant sensor has to be replaced soon	Refrigerant sensor (BQ10 (RS)) in the heat pump has to be replaced soon. If it is not replaced within {days} days, it will result in limited operation.	Refrigerant sensor (BQ10 (RS)) warns that it will soon be time to replace the sensor. The warning message will appear from 14.5 years, once a month, until 15 years.
288	247	Refrigerant sensor disconnected	Refrigerant sensor (BQ10 (RS)) is either out of range, has lost communication or is faulty.	Broken cable. Disconnected cable.
294	269	Non-compatible outd air heat pump	If the heat pump and indoor module are incompatible.	Heat pump and indoor module are not compatible.
343	293	Low temp water out	The supply temperature (BT12) out of the condenser is below the minimum temperature.	Low flow. Incorrect set values during cooling operation.
418	380	Flow protect defrost	If the flow is low for a certain amount of time, an alarm is triggered to cancel defrosting.	Low temperature. Dirt in filters. Low flow.
523	418	Low flow during defrosting	If the flow is low for a certain amount of time, an alarm is triggered to cancel defrosting.	Low temperature in the hot water tank. Dirt in filters.
580	421	Cold outd air, cool. mode	The outside temperature is too low to ensure safe operation.	Cold weather conditions. Sensor fault.
609	614	Sensor fault PCB	In the case of repeated sensor failures.	Sensor fault. Faulty circuit board.

Accessories

Detailed information about the accessories and complete accessories list available at nibe.eu.

Not all accessories are available on all markets.

CONDENSATION WATER PIPE KVR

KVR 15 suitable for S2060:

KVR 15-10

1 metres
Part no. 267 025

KVR 15-30

3 metres
Part no. 267 026

KVR 15-60

6 metres
Part no. 267 027

STAND AND BRACKETS

Ground stand GSU 40

S2060-6, -10
Part no. 067 965

Wall rack BAU 50

For wall mounting S2060-6, -10
Part no. 267 017

Technical data

Dimensions

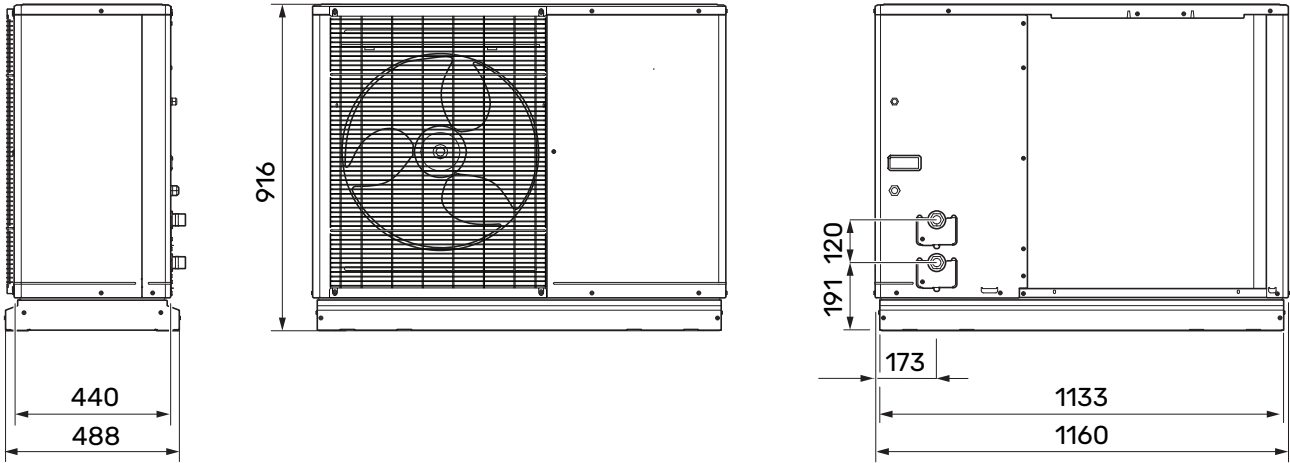

Sound levels

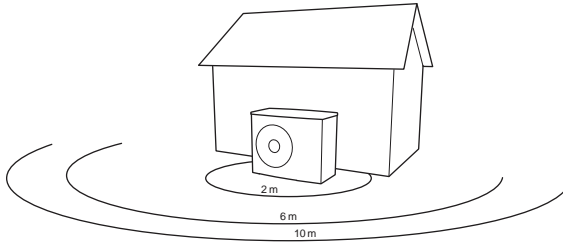

S2060 is usually placed next to a house wall, which gives a directed sound distribution that has to be taken into consideration. Accordingly, when setting up, you should always attempt to select the side that faces the least sound-sensitive neighbouring area.

The sound pressure levels are further affected by walls, bricks, differences in ground level, etc and should therefore only be seen as guide values.

S2060 adjusts the fan speed depending on the ambient temperature and evaporation temperature.

		Sound power ¹	Sound pressure at distance (m) ²									
			1	2	3	4	5	6	7	8	9	10
S2060-6	Nominal sound value	51	46.0	40.0	36.5	34.0	32.0	30.5	29.0	28.0	27.0	26.0
	Max. sound value	57	52.0	46.0	42.5	40.0	38.0	36.5	35.0	34.0	33.0	32.0
	Max. sound value, silent mode	50	45.0	39.0	35.5	33.0	31.0	29.5	28.0	27.0	26.0	25.0
S2060-10	Nominal sound value	54	49.0	43.0	39.5	37.0	35.0	33.5	32.0	31.0	30.0	29.0
	Max. sound value	60	55.0	49.0	45.5	43.0	41.0	39.5	38.0	37.0	36.0	35.0
	Max. sound value, silent mode	53	48.0	42.0	38.5	36.0	34.0	32.5	31.0	30.0	29.0	28.0

¹ Sound power level, $L_W(A)$, according to EN12102

² Sound pressure calculated according to directivity factor $Q=4$

Technical specifications

WORKING RANGE, HEATING

Supply temperature (°C)

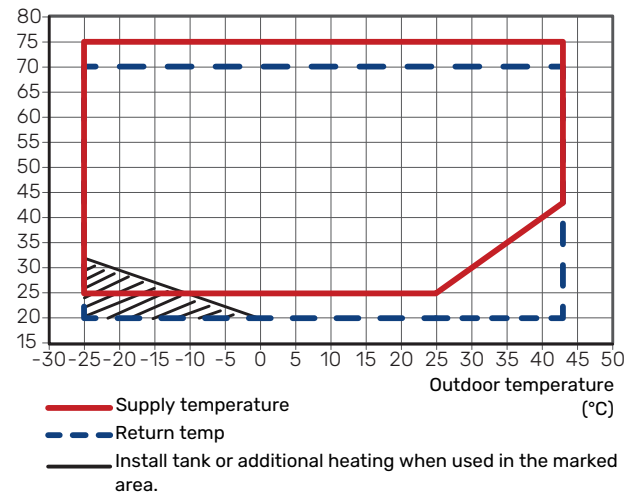

WORKING RANGE, COOLING

Supply temperature (°C)

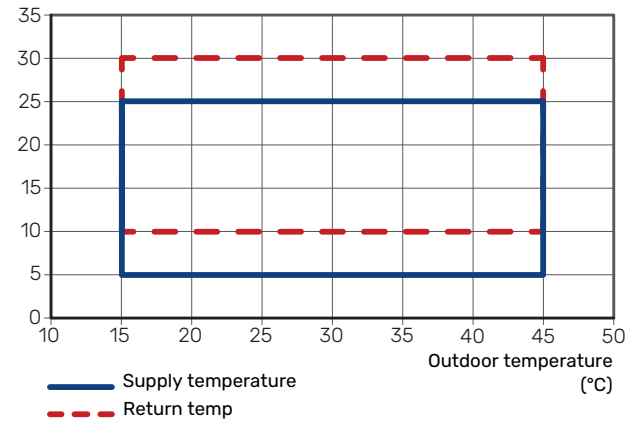

During shorter time it is allowed to have lower working temperatures on the water side, e.g. during start up.

POWER DURING HEATING OPERATION

Maximum and minimum capacity during continuous operation. Defrosting is not included.

S2060-6

Heating output (kW)

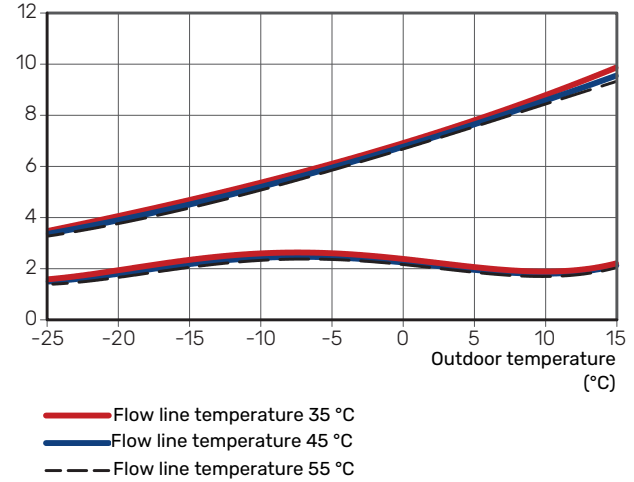

S2060-10

Heating output (kW)

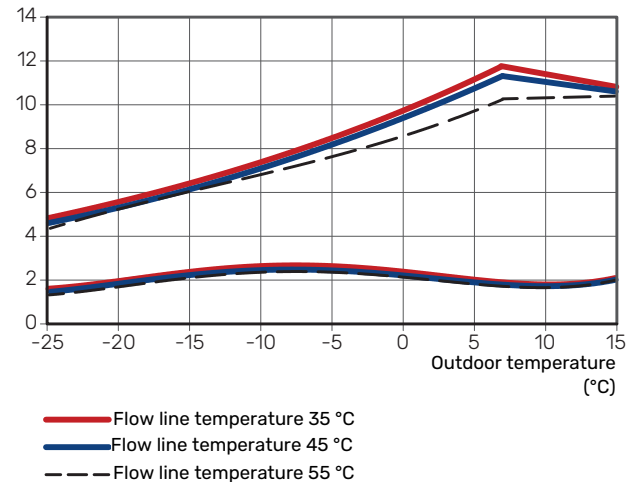

POWER DURING COOLING OPERATION

Maximum and minimum capacity during continuous operation.

S2060-6

Cooling output (kW)

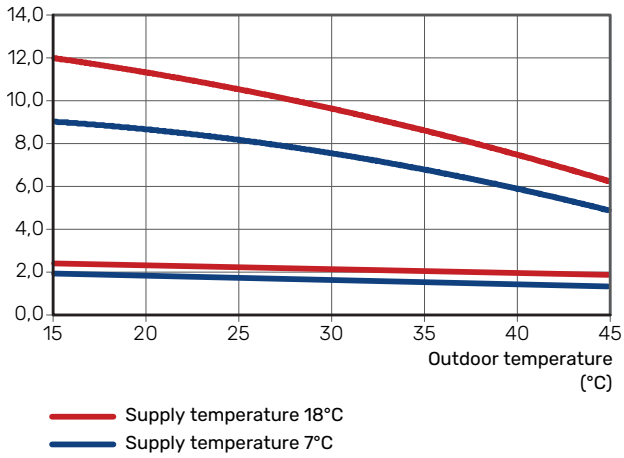

S2060-10

Cooling output (kW)

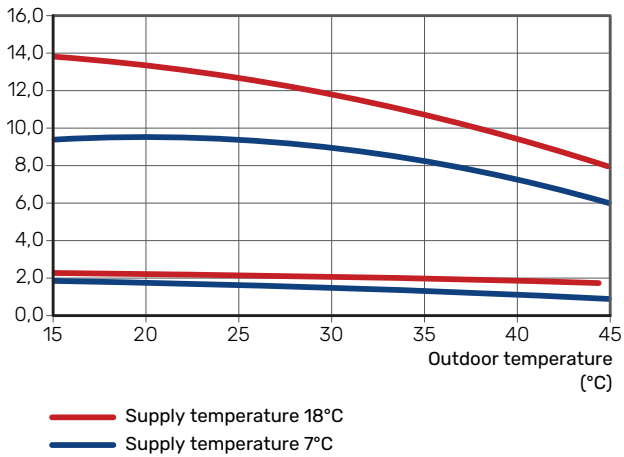

S2060		6	10
Voltage		1 x 230 V	1 x 230 V
Output data according to EN 14 511, partial load¹			
Heating	-7 / 35 °C	5.17 / 1.85 / 2.79	6.70 / 2.53 / 2.65
Capacity / power input / COP (kW/kW/-) at nominal flow	2 / 35 °C	3.32 / 0.68 / 4.88	3.61 / 0.76 / 4.77
Outdoor temp: / Supply temp.	2 / 45 °C	3.70 / 0.98 / 3.78	4.26 / 1.27 / 3.35
	7 / 35 °C	4.92 / 0.89 / 5.53	6.02 / 1.11 / 5.42
	7 / 45 °C	4.28 / 0.99 / 4.32	5.70 / 1.34 / 4.25
Cooling	35 / 7 °C	4.64 / 1.28 / 3.63	5.73 / 1.61 / 3.56
Capacity / power input / EER (kW/kW/-) at maximum flow	35 / 18 °C	8.48 / 2.33 / 3.64	10.76 / 2.66 / 4.05
Outdoor temp: / Supply temp.			
Maximum capacity			
Maximum capacity, heating, at A7W35 without defrosting	kW	8.27	11.73
Maximum capacity, heating, at A2W55 with / without defrosting	kW	5.54 / 6.91	7.14 / 9.06
Maximum capacity, heating, at A-7W35 without defrosting	kW	5.78	8.04
SCOP according to EN 14825			
Nominal heat output (P _{designh}) average climate 35 °C / 55 °C (Europe)	kW	4.8 / 5.3	6.5 / 7.0
Nominal heat output (P _{designh}) cold climate 35 °C / 55 °C	kW	5.5 / 5.7	8.0 / 7.8
Nominal heat output (P _{designh}) warm climate 35 °C / 55 °C	kW	5.2 / 5.5	6.5 / 7.2
SCOP average climate, 35 °C / 55 °C (Europe)		5.33 / 4.19	5.07 / 4.02
SCOP cold climate, 35 °C / 55 °C		4.12 / 3.63	4.42 / 3.59
SCOP warm climate, 35 °C / 55 °C		6.64 / 5.06	6.46 / 4.83
Energy rating, average climate²			
The product's room heating efficiency class 35 °C / 55 °C ³		A+++ / A+++	A+++ / A+++
The system's room heating efficiency class 35 °C / 55 °C ⁴		A+++ / A+++	
Electrical data			
Rated voltage		230 V ~ 50 Hz	230 V ~ 50 Hz
Rated current, heat pump	A _{rms}	13	16
Max. power, fan	W	59	
Fuse	A _{rms}	16	
Enclosure class		IP24	
Refrigerant circuit			
Type of refrigerant		R290	
GWP refrigerant		0.02	
Filling amount	kg	0.65	0.85
Type of compressor		Rotary compressor	Rotary compressor
CO ₂ -equivalent (The cooling circuit is hermetically sealed.)	kg	0.013	0.017
Cut-out value pressure switch HP (BP1)	MPa (bar)	3.20 (32.0)	
Difference pressostat HP	MPa (bar)	0.8 (8.0)	
Airflow			
Max airflow	m ³ /h	42	50
Working area			
Min./max. air temperature, heating	°C	-25 / 43	
Min./max. air temperature, cooling	°C	15 / 45	
Defrosting system		Reverse cycle	
Heating medium circuit			
Max system pressure heating medium	MPa (bar)	0.3 (3.0)	
Cut-off pressure, heating medium	MPa (bar)	0.3 (3.0)	
Recommended flow interval, heating operation	l/s	0.08 – 0.42	0.12 – 0.50
Min. design flow, defrosting (100% pump speed)	l/s	0.14	0.21
Min./max. HM temp, continuous operation	°C	25 / 75	
Min./max. HM temp, continuous operation, cooling	°C	5 / 25	
Connection heating medium S2060		G1" external thread	
Connection heating medium flex pipe		G1" external thread	
Min. recommended pipe dimension (system)	DN (mm)	DN (mm) 20 (22)	
Dimensions and weight			
Width	mm	1,160	1,160
Depth	mm	488	488
Height	mm	916	916

S2060		6	10
Weight	kg	84	91
Miscellaneous			
Part no.		064 381	064 382

- 1 Power statements including defrosting according to EN 14511 at heating medium supply corresponding to DT=5 K at 7 / 45.
- 2 The reported efficiency of the package also takes the controller into account. If an external supplementary boiler or solar heating is added to the package, the overall efficiency of the package should be recalculated.
- 3 Scale for the product's efficiency class room heating: A+++ to D. Control module model SMO S.
- 4 Scale for the system's efficiency class room heating: A+++ to G. Reported efficiency for the system takes the product's temperature regulator into account. Control module model SMO S.

Energy labelling

INFORMATION SHEET

Supplier		NIBE	
Model		S2060-6 1x230 V	S2060-10 1x230 V
Temperature application	°C	35 / 55	35 / 55
Seasonal space heating energy efficiency class, average climate		A+++ / A+++	A+++ / A+++
Rated heat output (P_{designh}), average climate	kW	5 / 5	7 / 7
Annual energy consumption space heating, average climate	kWh	1,854 / 2,603	2,648 / 3,601
Seasonal space heating energy efficiency, average climate	%	211 / 165	200 / 158
Sound power level L_{WA} indoors	dB	-	-
Rated heat output (P_{designh}), cold climate	kW	6 / 6	8 / 8
Rated heat output (P_{designh}), warm climate	kW	5 / 6	7 / 7
Annual energy consumption space heating, cold climate	kWh	3,152 / 3,768	4,458 / 5,352
Annual energy consumption space heating, warm climate	kWh	1,040 / 1,442	1,344 / 1,992
Seasonal space heating energy efficiency, cold climate	%	169 / 146	174 / 141
Seasonal space heating energy efficiency, warm climate	%	264 / 201	255 / 190
Sound power level L_{WA} outdoors	dB	51	54

DATA FOR ENERGY EFFICIENCY OF THE PACKAGE

Model		S2060-6 1x230 V	S2060-10 1x230 V
Control module model		SMO	SMO
Temperature application	°C	35 / 55	35 / 55
Controller, class		VI	
Controller, contribution to efficiency	%	4.0	
Seasonal space heating energy efficiency of the package, average climate	%	211 / 165	200 / 158
Seasonal space heating energy efficiency class of the package, average climate		A+++ / A+++	A+++ / A+++
Seasonal space heating energy efficiency of the package, cold climate	%	169 / 146	174 / 141
Seasonal space heating energy efficiency of the package, warm climate	%	264 / 201	255 / 190

The reported efficiency of the package also takes the controller into account. If an external supplementary boiler or solar heating is added to the package, the overall efficiency of the package should be recalculated.

TECHNICAL DOCUMENTATION

Model		S2060-6 1x230 V					
Type of heat pump	<input checked="" type="checkbox"/> Air-water <input type="checkbox"/> Exhaust-water <input type="checkbox"/> Brine-water <input type="checkbox"/> Water-water						
Low-temperature heat pump	<input type="checkbox"/> Yes <input checked="" type="checkbox"/> No						
Integrated immersion heater for additional heat	<input type="checkbox"/> Yes <input checked="" type="checkbox"/> No						
Heat pump combination heater	<input type="checkbox"/> Yes <input checked="" type="checkbox"/> No						
Climate	<input checked="" type="checkbox"/> Average <input type="checkbox"/> Cold <input type="checkbox"/> Warm						
Temperature application	<input checked="" type="checkbox"/> Medium (55°C) <input type="checkbox"/> Low (35°C)						
Applied standards	EN14511 / EN14825 / EN12102						
Rated heat output	Prated	5.3	kW	Seasonal space heating energy efficiency	η_s	165	%
Declared capacity for space heating at part load and at outdoor temperature T_j				Declared coefficient of performance for space heating at part load and at outdoor temperature T_j			
$T_j = -7\text{ °C}$	Pdh	5.1	kW	$T_j = -7\text{ °C}$	COPd	2.51	-
$T_j = +2\text{ °C}$	Pdh	2.8	kW	$T_j = +2\text{ °C}$	COPd	4.24	-
$T_j = +7\text{ °C}$	Pdh	1.7	kW	$T_j = +7\text{ °C}$	COPd	5.28	-
$T_j = +12\text{ °C}$	Pdh	1.2	kW	$T_j = +12\text{ °C}$	COPd	6.80	-
$T_j = \text{biv}$	Pdh	5.1	kW	$T_j = \text{biv}$	COPd	2,14	-
$T_j = \text{TOL}$	Pdh	4.8	kW	$T_j = \text{TOL}$	COPd	2.16	-
$T_j = -15\text{ °C}$ (if TOL < -20 °C)	Pdh		kW	$T_j = -15\text{ °C}$ (if TOL < -20 °C)	COPd		-
Bivalent temperature	T_{biv}	-10	°C	Min. outdoor air temperature	TOL	-10	°C
Cycling interval capacity	P _{cy}		kW	Cycling interval efficiency	COP _{cy}		-
Degradation coefficient	Cdh	0.93	-	Max supply temperature	WTOL	65	°C
<i>Power consumption in modes other than active mode</i>				<i>Additional heat</i>			
Off mode	P _{OFF}	0.002	kW	Rated heat output	P _{sup}	0.0	kW
Thermostat-off mode	P _{TO}	0.012	kW				
Standby mode	P _{SB}	0.009	kW	Type of energy input	Electric		
Crankcase heater mode	P _{CK}	0.000	kW				
<i>Other items</i>							
Capacity control	Variable			Rated airflow (air-water)		2,520	m ³ /h
Sound power level, indoors/outdoors	L _{WA}	- / 51	dB	Nominal heating medium flow			m ³ /h
Annual energy consumption	Q _{HE}	2,603	kWh	Brine flow brine-water or water-water heat pumps			m ³ /h
Contact information	NIBE Energy Systems - Box 14 - Hannabadsvägen 5 - 285 21 Markaryd - Sweden						

Model		S2060-10 1x230 V					
Type of heat pump	<input checked="" type="checkbox"/> Air-water <input type="checkbox"/> Exhaust-water <input type="checkbox"/> Brine-water <input type="checkbox"/> Water-water						
Low-temperature heat pump	<input type="checkbox"/> Yes <input checked="" type="checkbox"/> No						
Integrated immersion heater for additional heat	<input type="checkbox"/> Yes <input checked="" type="checkbox"/> No						
Heat pump combination heater	<input type="checkbox"/> Yes <input checked="" type="checkbox"/> No						
Climate	<input checked="" type="checkbox"/> Average <input type="checkbox"/> Cold <input type="checkbox"/> Warm						
Temperature application	<input checked="" type="checkbox"/> Medium (55°C) <input type="checkbox"/> Low (35°C)						
Applied standards	EN14511 / EN14825 / EN12102						
Rated heat output	Prated	7.0	kW	Seasonal space heating energy efficiency	η_s	156	%
Declared capacity for space heating at part load and at outdoor temperature T_j				Declared coefficient of performance for space heating at part load and at outdoor temperature T_j			
$T_j = -7\text{ °C}$	Pdh	6.2	kW	$T_j = -7\text{ °C}$	COPd	2.30	-
$T_j = +2\text{ °C}$	Pdh	3.8	kW	$T_j = +2\text{ °C}$	COPd	4.16	-
$T_j = +7\text{ °C}$	Pdh	2.4	kW	$T_j = +7\text{ °C}$	COPd	5.02	-
$T_j = +12\text{ °C}$	Pdh	1.2	kW	$T_j = +12\text{ °C}$	COPd	5.90	-
$T_j = \text{biv}$	Pdh	6.9	kW	$T_j = \text{biv}$	COPd	2.08	-
$T_j = \text{TOL}$	Pdh	6.4	kW	$T_j = \text{TOL}$	COPd	2.00	-
$T_j = -15\text{ °C}$ (if TOL < -20 °C)	Pdh		kW	$T_j = -15\text{ °C}$ (if TOL < -20 °C)	COPd		-
Bivalent temperature	T_{biv}	-10	°C	Min. outdoor air temperature	TOL	-10	°C
Cycling interval capacity	P _{cy}		kW	Cycling interval efficiency	COP _{cy}		-
Degradation coefficient	Cdh	0.91	-	Max supply temperature	WTOL	60	°C
Power consumption in modes other than active mode				Additional heat			
Off mode	P _{OFF}	0.002	kW	Rated heat output	P _{sup}	0.0	kW
Thermostat-off mode	P _{TO}	0.018	kW				
Standby mode	P _{SB}	0.012	kW	Type of energy input	Electric		
Crankcase heater mode	P _{CK}	0.000	kW				
<i>Other items</i>							
Capacity control	Variable			Rated airflow (air-water)		3,000	m ³ /h
Sound power level, indoors/outdoors	L _{WA}	- / 54	dB	Nominal heating medium flow			m ³ /h
Annual energy consumption	Q _{HE}	3,601	kWh	Brine flow brine-water or water-water heat pumps			m ³ /h
Contact information	NIBE Energy Systems – Box 14 – Hannabadsvägen 5 – 285 21 Markaryd – Sweden						

Item register

- 1**
 - 1x230 V, 19
- A**
 - Accessories, 29
 - Activating S2060, 22
 - Adjustment, charge flow, 20
 - Alarm list, 26
 - Assembly, 6
- B**
 - Basic actions, 25
- C**
 - Cable routing, communication, 19
 - Cascade connection, 19
 - Charge pump, 20
 - Commissioning, 20
 - Commissioning and adjusting, 20
 - Adjustment, charge flow, 20
 - Charge pump, 20
 - Commissioning, 20
 - Pressure drop, heating medium side, 20
 - Topping up, 20
 - Venting, 20
 - Communication, 19
 - Condensation, 8
 - Connections, 19
 - Control, 21
 - Control - Introduction, 21
 - General, 21
 - Control - Heat pump EB101
 - Heat pump settings - 5.11.1.1, 23
 - Heat pump settings - Menu 7.3.2, 22
 - Control - Introduction, 21
- D**
 - Data for discharge sensor, 24
 - Data for energy efficiency of the system, 37
 - Delivery and handling, 6
 - Assembly, 6
 - Condensation, 8
 - Handling panels, 10
 - Installation area, 7
 - Installing the plinth, 9
 - Lift to installation location, 6
 - Supplied components, 9
 - Transport, 6
 - Dimensions and setting-out coordinates, 30
 - DIP switches, 19
 - Dismantling cardboard box, 10
 - Disturbances in comfort, 25
 - Alarm list, 26
 - Troubleshooting, 25
 - Draining the condenser, 24
- E**
 - Electrical circuit diagram, 40
 - Electrical connections, 18
 - 1x230 V, 19
 - Cable routing, communication, 19
 - Cascade connection, 19
 - Communication, 19
 - Connections, 19
 - DIP switches, 19
 - General, 18
 - Power connection, 19
 - Supply voltage, 19
 - Terminal blocks, 19
 - Energy labelling, 36
 - Data for energy efficiency of the package, 37
 - Information sheet, 36
 - Technical documentation, 38
- G**
 - General, 18
- H**
 - Handling panels, 10
 - Heat pump settings - 5.11.1.1, 23
 - Heat pump settings - Menu 7.3.2, 22
 - High room temperature, 25
- I**
 - Important information, 4
 - Inspection of the installation, 5
 - Safety information, 4
 - Serial number, 4
 - System solutions, 5
 - Information sheet, 36
 - Inspection of the installation, 5
 - Installation area, 7
 - Installing the enclosed fan grille, 11
 - Installing the installation
 - Symbol key, 16
 - Installing the plinth, 9
- L**
 - Large amount of water below S2060, 25
 - Lift to installation location, 6
 - List of components, 15
 - Low hot water temperature or no hot water, 25
 - Low room temperature, 25
- M**
 - Marking, 4
- P**
 - Pipe connections, 16
 - General, 16
 - Pipe connections flex hose, 17
 - Pipe coupling, heating medium, 17
 - Symbol key, 16
 - Water volumes, 16
 - Pipe connections flex hose, 17
 - Pipe coupling, heating medium, 17
 - Power connection, 19
 - Pressure drop, heating medium side, 20
- R**
 - Removing the front panel, 10
 - Removing the top panel, 10
 - Removing the transport safety devices, 10
 - Replacement of pressure sensor, condenser, 24
- S**
 - S2060 does not start, 25
 - S2060 not communicating, 25
 - Safety information, 4
 - Marking, 4
 - Symbols, 4
 - Serial number, 4
 - Service, 24
 - Replacement of pressure sensor, condenser, 24

- Service actions, 24
 - Temperature sensor data, 24
- Service actions, 24
 - Data for discharge sensor, 24
 - Temperature sensor data, 24
- Service measures
 - Draining the condenser, 24
- Sound levels, 31
- Supplied components, 9
- Supply voltage, 19
- Symbol key, 16
- Symbols, 4
- System solutions, 5
- T**
- Technical data, 30
 - Dimensions and setting-out coordinates, 30
 - Electrical circuit diagram, 40
 - Energy labelling, 36
 - Data for energy efficiency of the system, 37
 - Information sheet, 36
 - Technical documentation, 38
 - Sound pressure levels, 31
 - Technical Data, 32
- Technical Data, 32
- Technical documentation, 38
- Temperature sensor data, 24
- Terminal blocks, 19
- The heat pump design, 12
 - Component locations, 12
 - List of components, 15
- Topping up, 20
- Transport, 6
- Troubleshooting, 25
 - Basic actions, 25
 - High room temperature, 25
 - Large amount of water below S2060, 25
 - Low hot water temperature or no hot water, 25
 - Low room temperature, 25
 - S2060 does not start, 25
 - S2060 not communicating, 25
- V**
- Venting, 20

Contact information

AUSTRIA

NIBE GmbH
Gahberggasse 11
4861 Schörfling am Attersee
Tel: +43 (0)7662 8963-0
kontakt@nibe.at
nibe.at

FINLAND

NIBE Energy Systems Oy
Juurakkotie 3, 01510 Vantaa
Tel: +358 (0)9 274 6970
info@nibe.fi
nibe.fi

GREAT BRITAIN

NIBE Energy Systems Ltd
3C Broom Business Park,
Bridge Way, S41 9QG Chesterfield
Tel: +44 (0)330 311 2201
info@nibe.co.uk
nibe.co.uk

POLAND

NIBE-BIAWAR Sp. z o.o.
Al. Jana Pawła II 57, 15-703 Białystok
Tel: +48 (0)85 66 28 490
biawar.com.pl

CZECH REPUBLIC

Družstevní závody Dražice - strojírna
s.r.o.
Dražice 69, 29471 Benátky n. Jiz.
Tel: +420 326 373 801
nibe@nibe.cz
nibe.cz

FRANCE

NIBE Energy Systems France SAS
Zone industrielle RD 28
Rue du Pou du Ciel, 01600 Reyrieux
Tél: 04 74 00 92 92
info@nibe.fr
nibe.fr

NETHERLANDS

NIBE Energietechnik B.V.
Energieweg 31, 4906 CG Oosterhout
Tel: +31 (0)168 47 77 22
info@nibenl.nl
nibenl.nl

SWEDEN

NIBE Energy Systems
Box 14
Hannabadsvägen 5, 285 21 Markaryd
Tel: +46 (0)433-27 30 00
info@nibe.se
nibe.se

DENMARK

Vølund Varmeteknik A/S
Industrivej Nord 7B, 7400 Herning
Tel: +45 97 17 20 33
info@volundvt.dk
volundvt.dk

GERMANY

NIBE Systemtechnik GmbH
Am Reiherpfahl 3, 29223 Celle
Tel: +49 (0)5141 75 46 -0
info@nibe.de
nibe.de

NORWAY

ABK-Qviller AS
Brobekkeveien 80, 0582 Oslo
Tel: (+47) 23 17 05 20
post@abkqviller.no
nibe.no

SWITZERLAND

NIBE Wärmetechnik c/o ait Schweiz AG
Industriepark, CH-6246 Altishofen
Tel. +41 (0)58 252 21 00
info@nibe.ch
nibe.ch

For countries not mentioned in this list, contact NIBE Sweden or check nibe.eu for more information.

NIBE Energy Systems
Hannabadsvägen 5
Box 14
SE-285 21 Markaryd
info@nibe.se
nibe.eu

IHB EN 2612-2 831280

This is a publication from NIBE Energy Systems. All product illustrations, facts and data are based on the available information at the time of the publication's approval.

NIBE Energy Systems makes reservations for any factual or printing errors in this publication.

©2026 NIBE ENERGY SYSTEMS

