

Installer manual

NIBE

Split system

NIBE SPLIT SVM S332 / AMS 20



IHB EN 2547-3
631467

Quick guide

NAVIGATION

Select



Most options and functions are activated by lightly pressing on the display with your finger.

Scroll



If the menu has several sub-menus, you can see more information by dragging up or down with your finger.

Browse

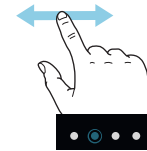

The symbols at the bottom edge show if there are more pages.

Drag to the right or left with your finger to browse between the pages.

Smartguide

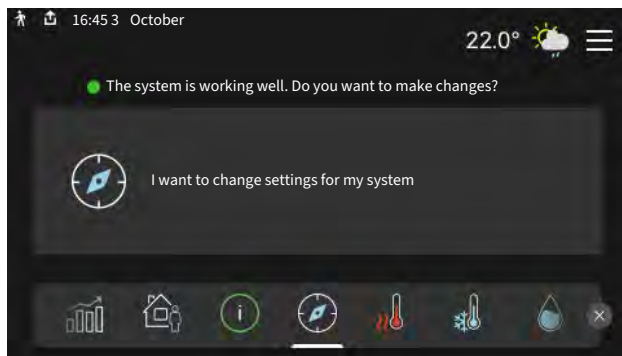

Smartguide helps you both to view information about the current status and to make the most common settings easily. The information that you see depends on the product you have and the accessories that are connected to the product.

Setting the indoor temperature.



Here, you can set the temperature in the installation's zones.

Increasing hot water temperature



Here, you can start or stop a temporary increase in the hot water temperature.

Product overview

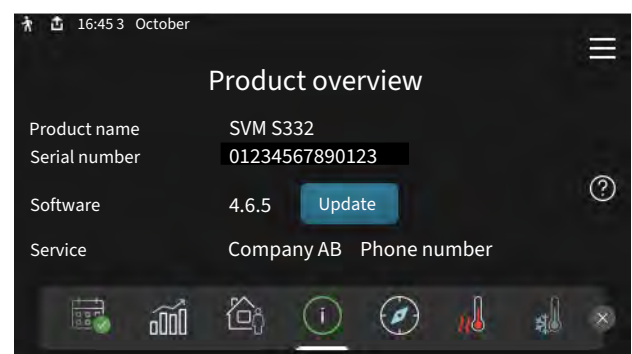

Here, you can find information about the product name, the product's serial number, the version of the software, and the contact details of the company that provides service. When there is new software to download, you can do it here (provided that SVM S332 is connected to myUplink).

Table of Contents

| | | | | |
|---|-----------------------------------|----|----------------------------|-----|
| 1 | Important information | 4 | Range of services | 44 |
| | Safety information | 4 | myUplink PRO | 44 |
| | Symbols | 4 | | |
| | Marking | 4 | 8 Control - Introduction | 45 |
| | Serial number | 4 | Display unit | 45 |
| | Inspection of the installation | 5 | Navigation | 46 |
| | Compatibility NIBE SPLIT | 6 | Menu types | 46 |
| | | | Climate systems and zones | 48 |
| 2 | Delivery and handling | 7 | 9 Control - Menus | 49 |
| | Transport indoor unit | 7 | Menu 1 - Indoor climate | 49 |
| | Set-up indoor unit | 7 | Menu 2 - Hot water | 53 |
| | Transport outdoor unit | 9 | Menu 3 - Info | 54 |
| | Set-up outdoor unit | 9 | Menu 4 - My system | 55 |
| | Supplied components | 12 | Menu 5 - Connection | 59 |
| | Handling the panels, indoor unit | 13 | Menu 6 - Scheduling | 60 |
| | Handling the panels, outdoor unit | 15 | Menu 7 - Service | 61 |
| 3 | The split system's design | 16 | 10 Service | 69 |
| | Indoor module's design | 16 | Service actions | 69 |
| | The outdoor unit's design | 18 | | |
| 4 | Pipe connections | 21 | 11 Disturbances in comfort | 74 |
| | General | 21 | Info-menu | 74 |
| | Dimensions and pipe connections | 23 | Manage alarm | 74 |
| | Connection of outdoor unit | 24 | Troubleshooting | 74 |
| | Use without outdoor unit | 25 | Alarm list | 76 |
| | Climate system | 25 | | |
| | Cold and hot water | 26 | 12 Accessories | 78 |
| | Installation alternative | 26 | | |
| 5 | Electrical connections | 28 | 13 Technical data | 80 |
| | General | 28 | Dimensions | 80 |
| | Connections | 30 | Dimensions, indoor unit | 80 |
| | Settings | 38 | Dimensions, outdoor unit | 81 |
| | | | Sound levels | 83 |
| 6 | Commissioning and adjusting | 39 | Installation requirements | 83 |
| | Compressor heater | 39 | Technical specifications | 84 |
| | Preparations | 39 | Energy labelling | 89 |
| | Filling and venting | 40 | Electrical circuit diagram | 92 |
| | Commissioning | 41 | | |
| | Setting the cooling/heating curve | 42 | Item register | 104 |
| 7 | myUplink | 44 | Contact information | 106 |
| | Specification | 44 | | |
| | Connection | 44 | | |

Important information

Safety information

This manual describes installation and service procedures for implementation by specialists.

The manual must be left with the customer.

For the latest version of the product's documentation, see nibe.eu.



CAUTION!

Also read the enclosed Safety Manual before starting the installation.

Symbols

Explanation of symbols that may be present in this manual.



CAUTION!

This symbol indicates danger to person or machine.



NOTE!

This symbol indicates important information about what you should consider when installing or servicing the installation.



TIP!

This symbol indicates tips on how to facilitate using the product.

Marking

Explanation of symbols that may be present on the product's label(s).



Fire hazard!



Flammable.



Dangerous voltage.



Danger to person or machine.



Read the User Manual.



Read the User Manual.



Read the Installer Manual.



Disconnect the voltage supply before starting work.

Serial number

The serial number can be found at the bottom right on SVM S332, in the display on the home screen "Product overview" and on the type plate (PZ1).

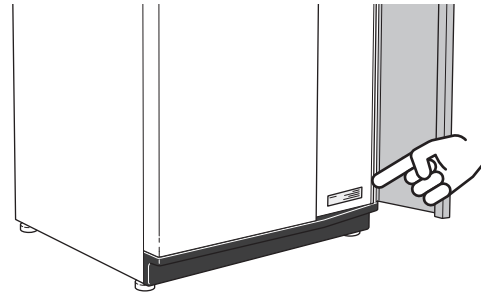

You can find the service code and the serial number on the right-hand side of AMS 20.

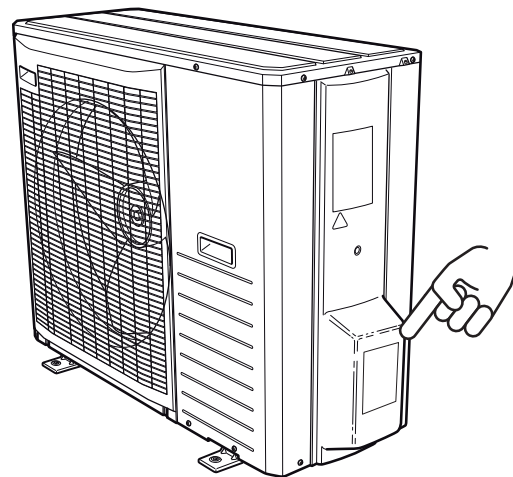

NOTE!

You need the product's service code and serial number for servicing and support.

Inspection of the installation

Current regulations require the heating installation to pass an installation inspection before it is commissioned. The inspection must be carried out by a suitably qualified person. In addition, complete the page in the User Manual for information about the installation data.

Connection of, and other work on, the refrigerant circuit may only be carried out by an accredited technician with the correct qualifications.

INSTALLATION INSPECTION INDOOR UNIT

| ✓ | Description | Notes | Signature | Date |
|---|--|-------|-----------|------|
| | Cold and hot water | | | |
| | Shut off valves | | | |
| | Mixing valve | | | |
| | Safety valve | | | |
| | Cooling circuit (section "Pipe connections") | | | |
| | Leak testing | | | |
| | Pipe insulation | | | |
| | Electrical connections | | | |
| | Connected communication | | | |
| | Circuit fuses | | | |
| | Fuses property | | | |
| | Outside sensor | | | |
| | Room sensor | | | |
| | Current sensor | | | |
| | Safety breaker | | | |
| | Earth circuit-breaker | | | |
| | Setting emergency mode | | | |
| | Cooling | | | |
| | Pipe system, condensation insulation | | | |

INSTALLATION INSPECTION OUTDOOR UNIT

| ✓ | Description | Notes | Signature | Date |
|---|--|-------|-----------|------|
| | Cooling circuit (section "Pipe connections") | | | |
| | System flushed | | | |
| | System evacuated | | | |
| | Vacuum attained | | | |
| | Single pipe length | | | |
| | Additional filling | | | |
| | Height difference | | | |
| | Pressurization test | | | |
| | Leak testing | | | |
| | Pipe insulation | | | |
| | Electricity (section "Electrical connections") | | | |
| | Group fuse | | | |
| | Safety breaker | | | |
| | Earth circuit-breaker | | | |
| | Heating cable type/effect | | | |
| | Communication cable connected | | | |
| | Miscellaneous | | | |
| | Condensation water pipe KVR | | | |
| | Cooling | | | |
| | Pipe system, condensation insulation | | | |

Compatibility NIBE SPLIT

| NIBE Indoor unit | NIBE Outdoor unit |
|------------------|-------------------|
| SVM S332-6 | AMS 20-6 |
| SVM S332-10 | AMS 20-10 |

Delivery and handling

Transport indoor unit

SVM S332 should be transported and stored vertically in a dry place.

However, the SVM S332 can be carefully laid on its back when being moved into the building.

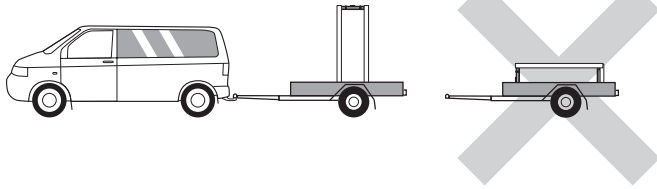

Set-up indoor unit

- Position SVM S332 on a solid foundation indoors that withstands water and the weight of the product.
- Use the product's adjustable feet to attain a horizontal and stable set-up.

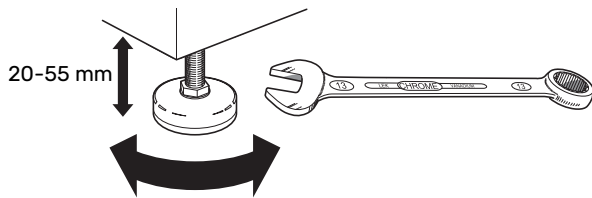

- The space where SVM S332 is located must be frost-free.
- Since water comes from SVM S332, the area where SVM S332 is located must be equipped with floor drainage.
- Install with its back to an outside wall, ideally in a room where noise does not matter, in order to eliminate noise problems. If this is not possible, avoid placing it against a wall behind a bedroom or other room where noise may be a problem.
- Wherever the unit is located, walls to sound sensitive rooms should be fitted with sound insulation.
- Route pipes so they are not fixed to an internal wall that backs on to a bedroom or living room.

INSTALLATION AREA

Leave a free space of 800 mm in front of the product and 400 mm above the product. All service on SVM S332 can be carried out from the front and above.

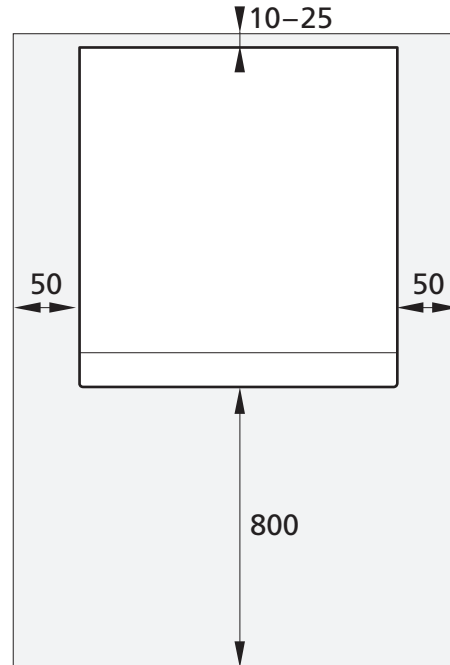

CAUTION!

Leave 10 – 25 mm free space between SVM S332 and the wall behind for routing cables and pipes.

REQUIREMENTS FOR INSTALLATION SPACE

For systems with a total refrigerant amount less than 1.84 kg R32, there is no space requirement.

AMS 20-6

AMS 20-6 is filled with 1.3 kg of refrigerant from the factory and therefore has no specific requirements regarding installation space. When the pipe length is max. 30 m, the refrigerant must be filled with max. 0.3 kg. The total refrigerant amount is always below the limit value of 1.84 kg.

AMS 20-10

AMS 20-10 is filled with 1.84 kg of refrigerant from the factory. When the pipe length is longer than 15 m, the refrigerant must be filled to max. 0.02 kg/ m. This because the total amount of refrigerant then exceeds 1.84 kg, the accessory AGS 10 (automatic gas separator) must be installed and consideration must be given to the size of the installation space with regard to the total amount of refrigerant. A total refrigerant amount exceeding 2.54 kg R32 is not permitted in the system.

Minimum floor area SVM S332-10

| Pipe length (m) | Filling amount (kg) | m _c (kg) ¹ | Floor area m ² |
|-----------------|---------------------|----------------------------------|---------------------------|
| ≤15 | 0.00 | 1.84 | |
| 16 | 0.02 | 1.86 | 4.50 |
| 17 | 0.04 | 1.88 | 4.55 |
| 18 | 0.06 | 1.90 | 4.60 |
| 19 | 0.08 | 1.92 | 4.65 |
| 20 | 0.10 | 1.94 | 4.70 |
| 21 | 0.12 | 1.96 | 4.74 |
| 22 | 0.14 | 1.98 | 4.79 |
| 23 | 0.16 | 2.00 | 4.84 |
| 24 | 0.18 | 2.02 | 4.89 |
| 25 | 0.20 | 2.04 | 4.94 |
| 26 | 0.22 | 2.06 | 4.99 |
| 27 | 0.24 | 2.08 | 5.04 |
| 28 | 0.26 | 2.10 | 5.08 |
| 29 | 0.28 | 2.12 | 5.13 |
| 30 | 0.30 | 2.14 | 5.18 |
| 31 | 0.32 | 2.16 | 5.23 |
| 32 | 0.34 | 2.18 | 5.28 |
| 33 | 0.36 | 2.20 | 5.33 |
| 34 | 0.38 | 2.22 | 5.37 |
| 35 | 0.40 | 2.24 | 5.42 |
| 36 | 0.42 | 2.26 | 5.47 |
| 37 | 0.44 | 2.28 | 5.52 |
| 38 | 0.46 | 2.30 | 5.57 |
| 39 | 0.48 | 2.32 | 5.62 |
| 40 | 0.50 | 2.34 | 5.66 |
| 41 | 0.52 | 2.36 | 5.71 |
| 42 | 0.54 | 2.38 | 5.76 |
| 43 | 0.56 | 2.40 | 5.81 |
| 44 | 0.58 | 2.42 | 5.86 |
| 45 | 0.60 | 2.44 | 5.91 |
| 46 | 0.62 | 2.46 | 5.95 |
| 47 | 0.64 | 2.48 | 6.00 |
| 48 | 0.66 | 2.50 | 6.05 |
| 49 | 0.68 | 2.52 | 6.10 |
| 50 | 0.70 | 2.54 | 6.15 |

¹ Total refrigerant amount

Transport outdoor unit

AMS 20 should be transported and stored vertically in a dry place.



CAUTION!

Ensure that the outdoor unit cannot fall over during transport.

Check that AMS 20 has not been damaged during transport.

LIFT FROM THE STREET TO THE SET UP LOCATION

If the surface allows, the easiest method is to use a pallet truck to move the outdoor unit to the installation area.

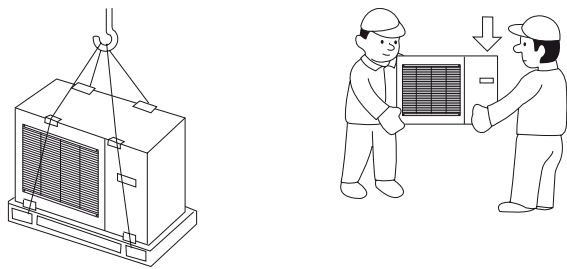

If the outdoor unit needs to be transported across soft ground, such as a lawn, we recommend using a crane truck that can lift it to the installation location. When lifting the outdoor unit with a crane, the packaging must be intact.

If a crane truck cannot be used, the outdoor unit can be transported on an extended sack truck. The outdoor unit must be taken hold of from its heaviest side and lifting it needs two people.

LIFT FROM THE PALLET TO FINAL POSITIONING

Before lifting remove the packaging and the securing strap to the pallet.

Place lifting straps around each foot. It is recommended that two people perform the lift from the pallet to the base.

SCRAPPING

When scrapping, remove the outdoor unit in reverse order. In this case, lift by the base plate rather than the pallet!

Set-up outdoor unit

- Place AMS 20 outdoors on a solid level base that can take the weight, preferably a concrete foundation. If concrete slabs are used they must rest on asphalt or shingle.
- The concrete foundation or slabs must be positioned so that the lower edge of the evaporator is at the level of the average local snow depth, however a minimum of 300 mm.
- Do not place AMS 20 directly on the lawn or other non solid surface.

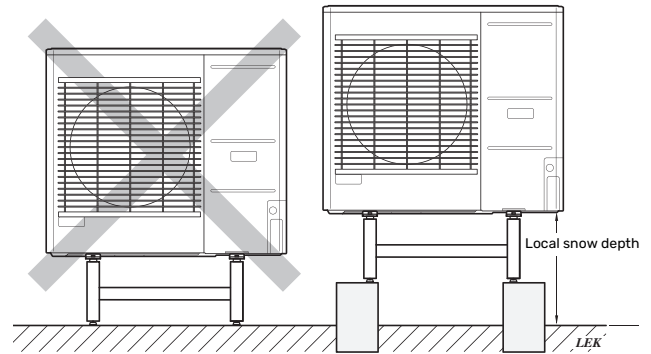

- AMS 20 should not be positioned next to noise sensitive walls, for example, next to a bedroom.
- Also ensure that the placement does not inconvenience the neighbours.
- AMS 20 must not be placed so that recirculation of the outdoor air can occur. This causes lower output and impaired efficiency.
- The evaporator should be sheltered from direct wind, which negatively affects the defrosting function. Place AMS 20 protected from wind against the evaporator.
- If there is a risk of snow sliding off the roof a protective canopy or similar should be installed over the outdoor unit, pipes and wiring.

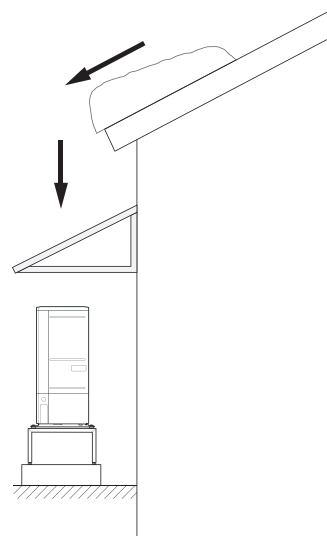

- Large amounts of condensation water, as well as melt water from defrosting, can be produced. Condensation water must be led off to a drain or equivalent.
- Take care to prevent scratching the outdoor unit during installation.

INSTALLATION AREA

Leave a free space of at least 150 mm between SVM S332 and the house wall, but not more than 500 mm in windy locations.

Leave a free space of 1,000 mm in front of, and 1,000 mm above, the product.

Approx. 300 mm free space is needed on the right-hand side to allow the front panel to be removed.

The lower edge of the evaporator must not be lower than the level of the average local snow depth, or at least 300 mm above ground level. The base should be at least 70 mm tall.

AMS 20

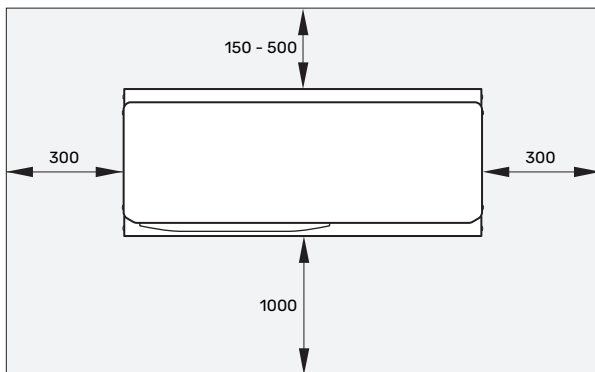

CONDENSATION

Condensation runs out on to the ground below AMS 20. To avoid damage to the house and outdoor unit, the condensation must be collected and drained away.



CAUTION!

It is important for the outdoor unit's function that the condensation water is led away and that the outlet for the condensation water pipe is positioned so as to prevent damage to the building.

Pipe with heating cable (KVR), for draining the condensate drip tray, is not included. To guarantee this function, the accessory KVR should be used.

- The condensation water (up to 50 litres / 24 hrs) must be routed away by a pipe to an appropriate drain, it is recommended that the shortest outdoor length possible is used.
- The section of the pipe that can be affected by frost must be heated by the heating cable to prevent freezing.
- Route the pipe downward from the outdoor unit.
- The outlet of the condensation water pipe must be at frost free depth.
- Use a water trap for installations where air circulation may occur in the condensation water pipe.
- The insulation must seal against the bottom of the condensation water trough.

Condensate drip tray heater, control

The condensate drip tray heater starts when the following conditions are met:

1. The compressor has been in operation for at least 30 minutes after last start.
2. The ambient temperature is lower than 1 °C.

Drainage of condensation



NOTE!

If none of the following recommended alternatives is used, good drainage of condensation must be provided.

Stone caisson

If the house has a cellar, the stone caisson must be positioned to prevent the condensation water from affecting the house. Otherwise, the stone caisson can be positioned directly under the outdoor unit.

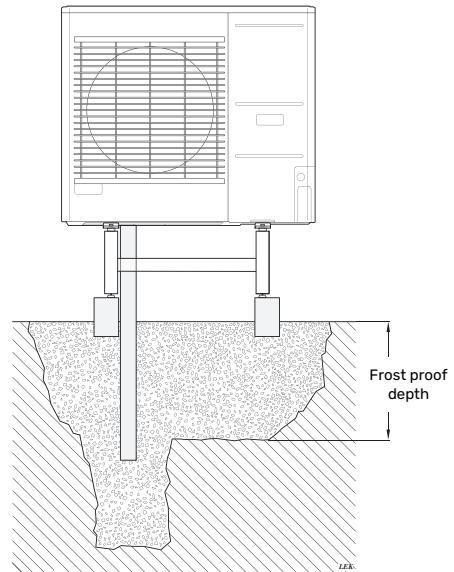

Gutter drainage

Route the pipe sloping down from the outdoor unit. The condensation water pipe must have a water seal to prevent air circulation in the pipe. The installation length can be adjusted by the size of the water seal.

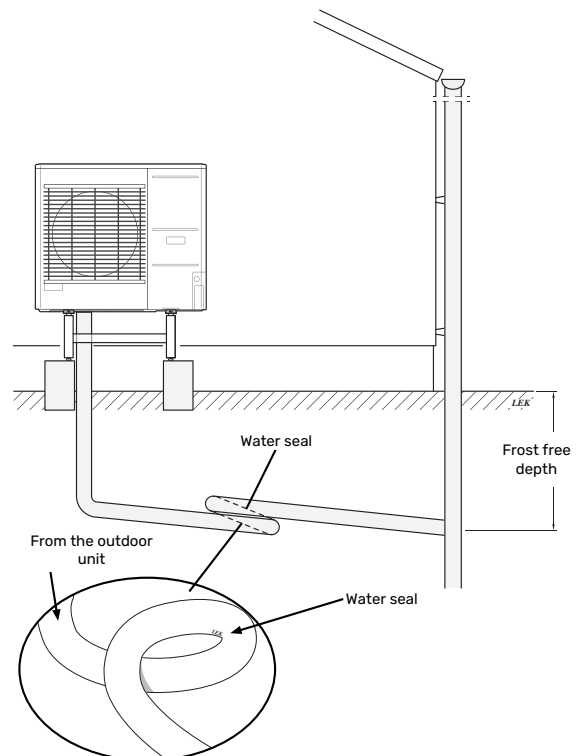

Supplied components

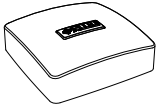

Outdoor temperature sensor
(BT1)
1 x

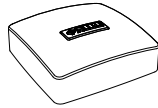

Room sensor(BT50)
1 x



Current sensor¹
3 x

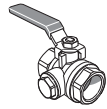

Filterball valve for the climate
system (G1") (QZ2.2)
1 x



Filterball valve for incoming
cold water (QZ2.1)
1 x

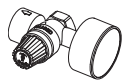

Combined safety valve
(FL2)/pressure gauge, heat-
ing medium (BP5)
1 x



Vent hose
2 x



Clips
1 x



O-ring
8 x

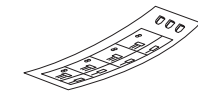

Label for external control
voltage for the control sys-
tem
1 x

¹ Only SVM S332 3x400 V.

LOCATION

The kit of enclosed items is placed on top of the indoor module.

Handling the panels, indoor unit

OPEN FRONT HATCH

Press the hatch's top left corner to open it.



REMOVE THE FRONT

1. Remove the screw in the hole next to the on/off button (SF1).

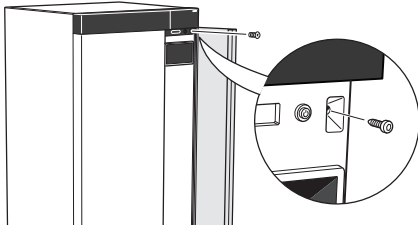

2. Pull the panel's top edge towards you and lift diagonally upwards to remove it from the frame.

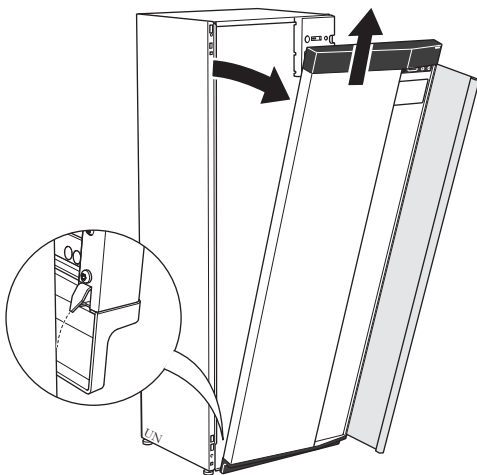

ASSEMBLE THE FRONT

1. Hook one bottom corner of the front onto the frame.

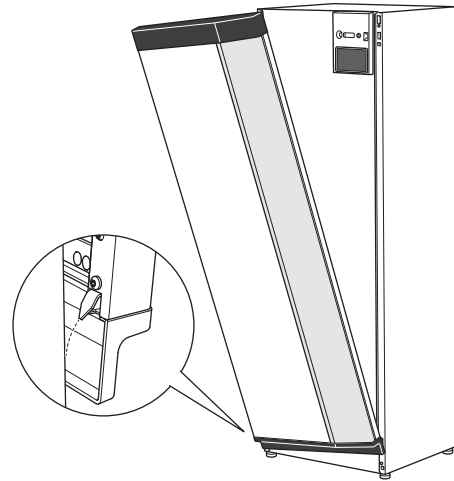

2. Hook the other corner in place.

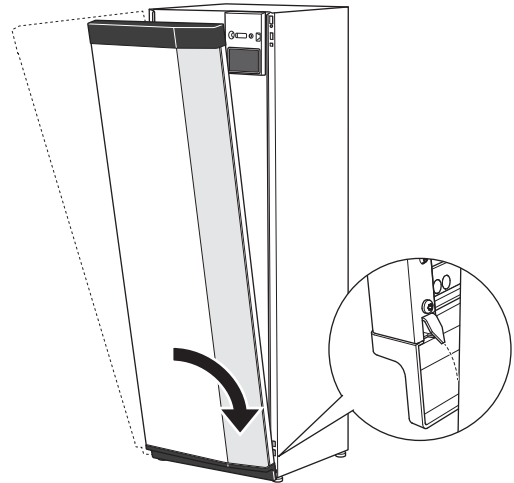

3. Check the display is straight. Adjust if necessary.

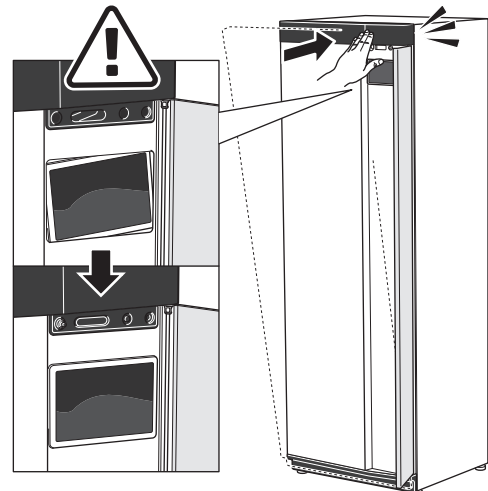

4. Press the top of the front section against the frame and screw it into place.

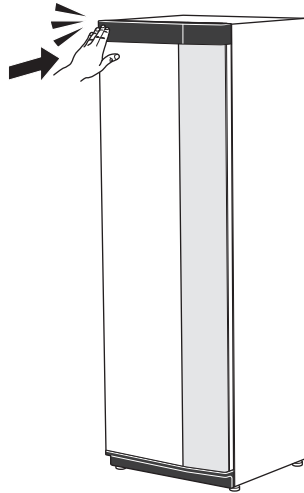

REMOVE SIDE PANEL

The side panels can be removed to facilitate the installation.

1. Remove the screws from the upper and lower edges.

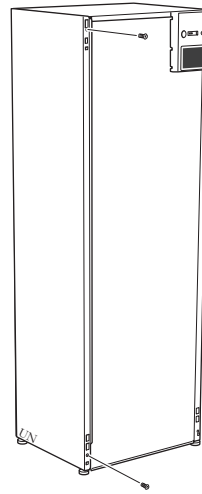

2. Turn the panel outwards slightly.

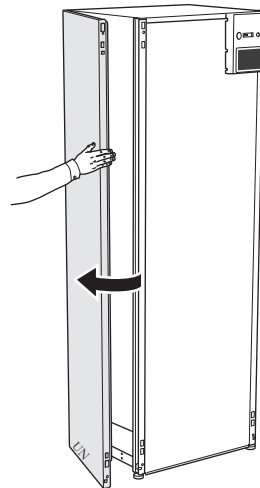

3. Move the panel outwards and backwards.

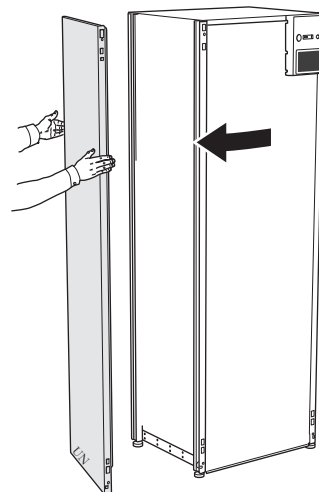

4. Assembly takes place in the reverse order.

Handling the panels, outdoor unit AMS 20-10

AMS 20-6

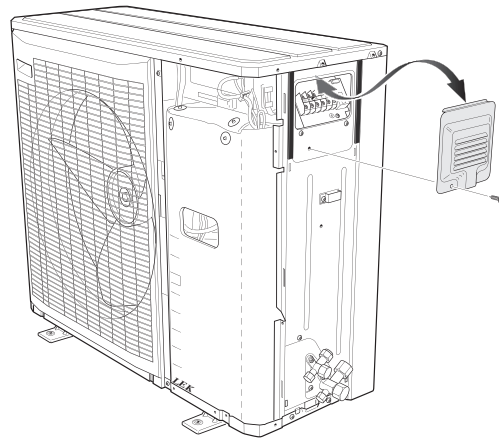
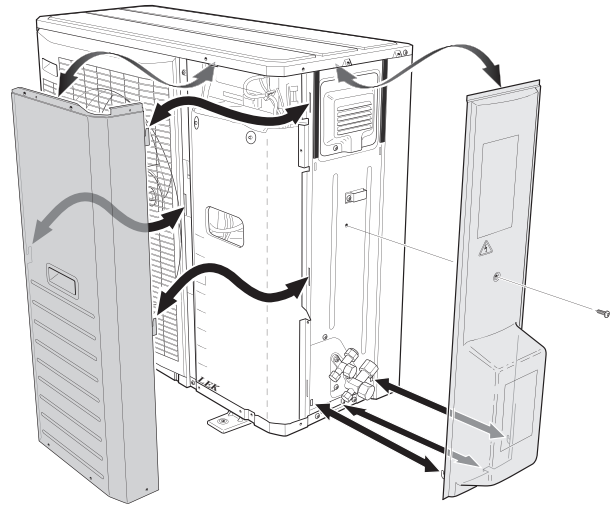
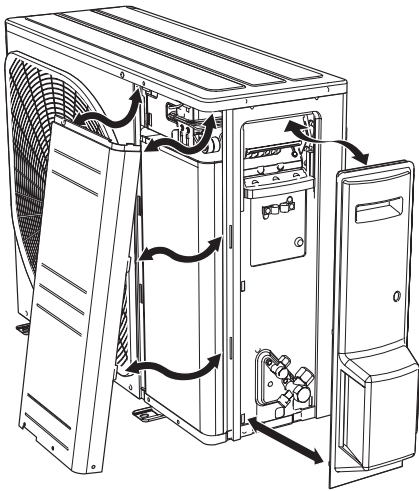
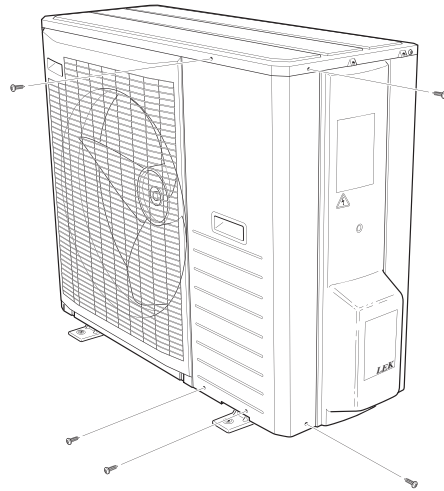
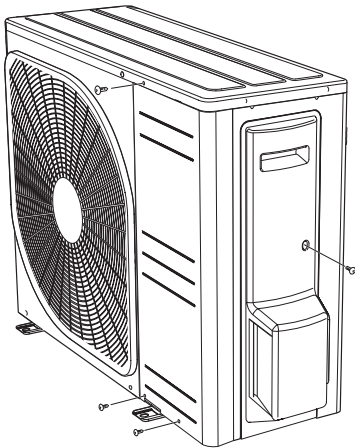

The split system's design

Indoor module's design

1x230 V

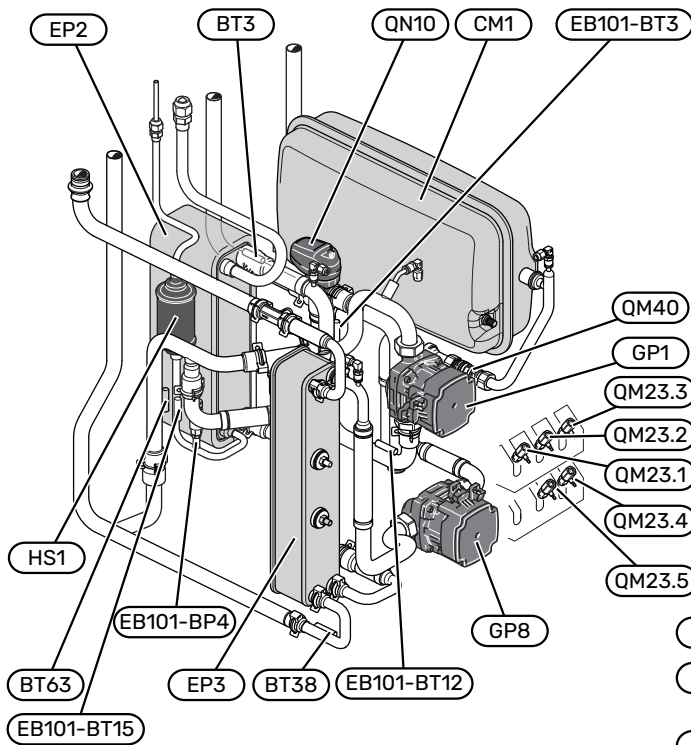

3x400 V

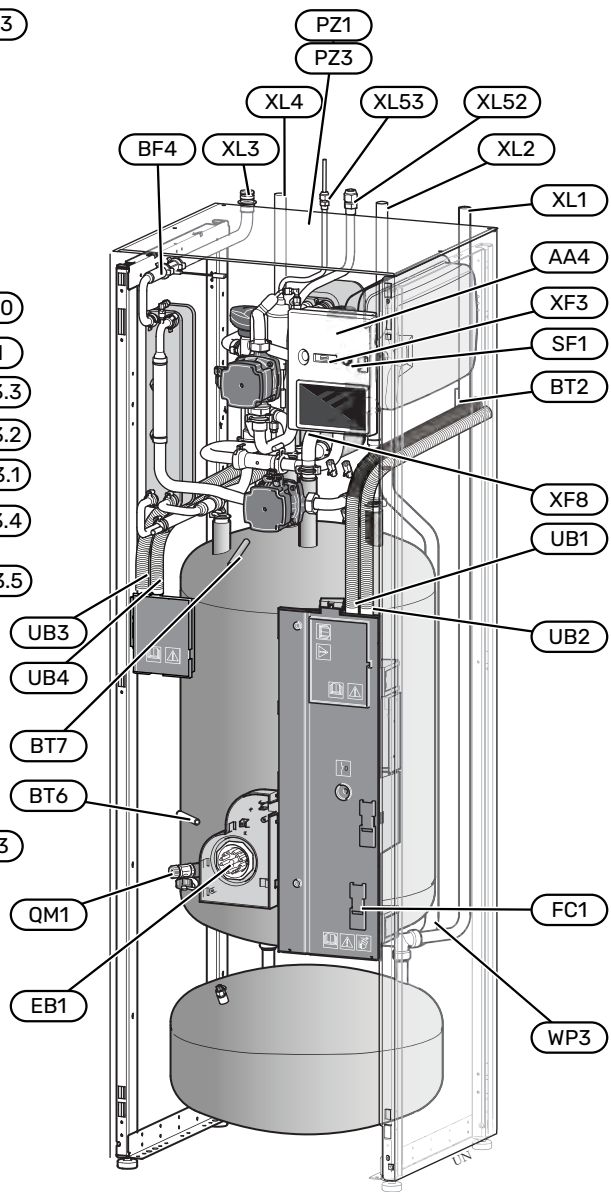
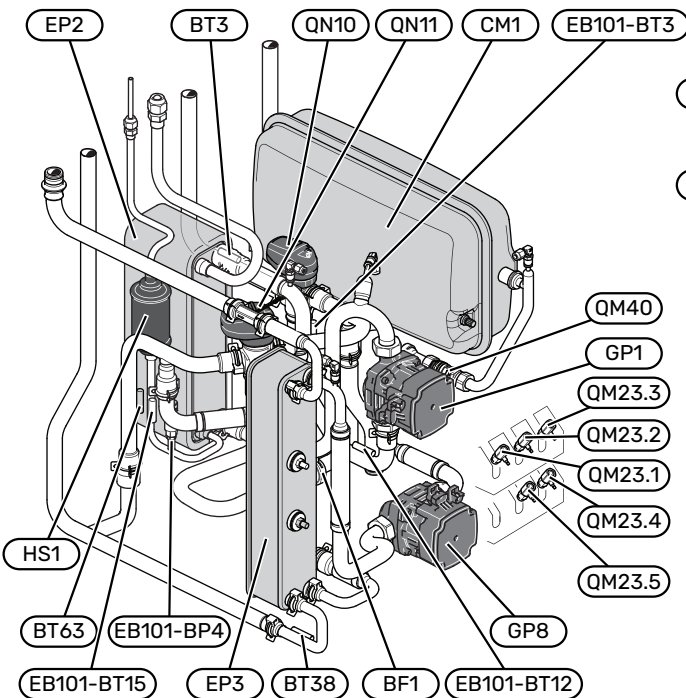

Pipe connections

| | |
|------|---|
| XL1 | Heating medium connection, supply |
| XL2 | Heating medium connection, return |
| XL3 | Cold water connection |
| XL4 | Hot water connection |
| XL52 | Gas line connection, supply, from outdoor unit |
| XL53 | Liquid line connection, return, to outdoor unit |

HVAC components

| | |
|--------|--------------------------------------|
| CM1 | Expansion vessel, climate system |
| EP3 | Hot water heat exchanger |
| GP1 | Circulation pump |
| GP8 | Charge pump hot water |
| QM1 | Drain valve, heating medium |
| QM23.1 | Vent valve, buffer vessel |
| QM23.2 | Vent valve, expansion vessel |
| QM23.3 | Vent valve, hot water heat exchanger |
| QM23.4 | Vent valve, heating medium pump |
| QM23.5 | Vent valve, condenser |
| QM40 | Shut-off valve |
| QN10 | Diverter valve, heating/hot water |
| QN11 | Shunt valve ¹ |
| WP3 | Overflow pipe for condensation |

¹ Only SVM S332 3x400 V.

Sensors etc.

| | |
|----------------|---|
| BF1 | Flow meter ¹ |
| BF4 | Flow meter hot water |
| EB101- BP4 | Pressure sensor, condenser |
| BT2 | Flow line sensor |
| EB101- BT3 | Return line sensor (connected to AA23) |
| BT6 | Controlling hot water sensor |
| BT7 | Display hot water sensor |
| EB101- BT12 | Supply temperature sensor after condenser |
| EB101- BT15 | Fluid line sensor |
| BT38 | Hot water sensor, outgoing hot water |
| BT63 | Supply temperature sensor after additional heat |

¹ Only SVM S332 3x400 V.

Electrical components

| | |
|-----|--|
| AA4 | Display unit |
| EB1 | Immersion heater |
| FC1 | Miniature circuit breaker ¹ |
| SF1 | On/off button |
| XF3 | USB socket |
| XF8 | Network connection for myUplink |

¹ Only SVM S332 1x230 V

Cooling components

| | |
|-----|---------------|
| EP2 | Condenser |
| HS1 | Drying filter |

Miscellaneous

| | |
|---------|---------------|
| PZ1 | Rating plate |
| PZ3 | Serial number |
| UB1-UB4 | Cable gland |

Designations according to standard EN 81346-2.

DISTRIBUTION BOXES

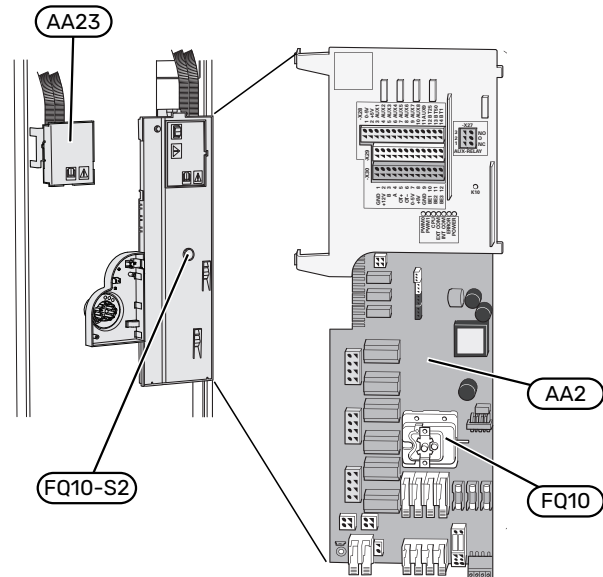

Electrical components

| | |
|------|--|
| AA2 | Base card |
| FQ10 | Temperature limiter |
| | FQ10-S2 Reset button for temperature limiter |
| AA23 | Communication board |

The outdoor unit's design

AMS 20-6

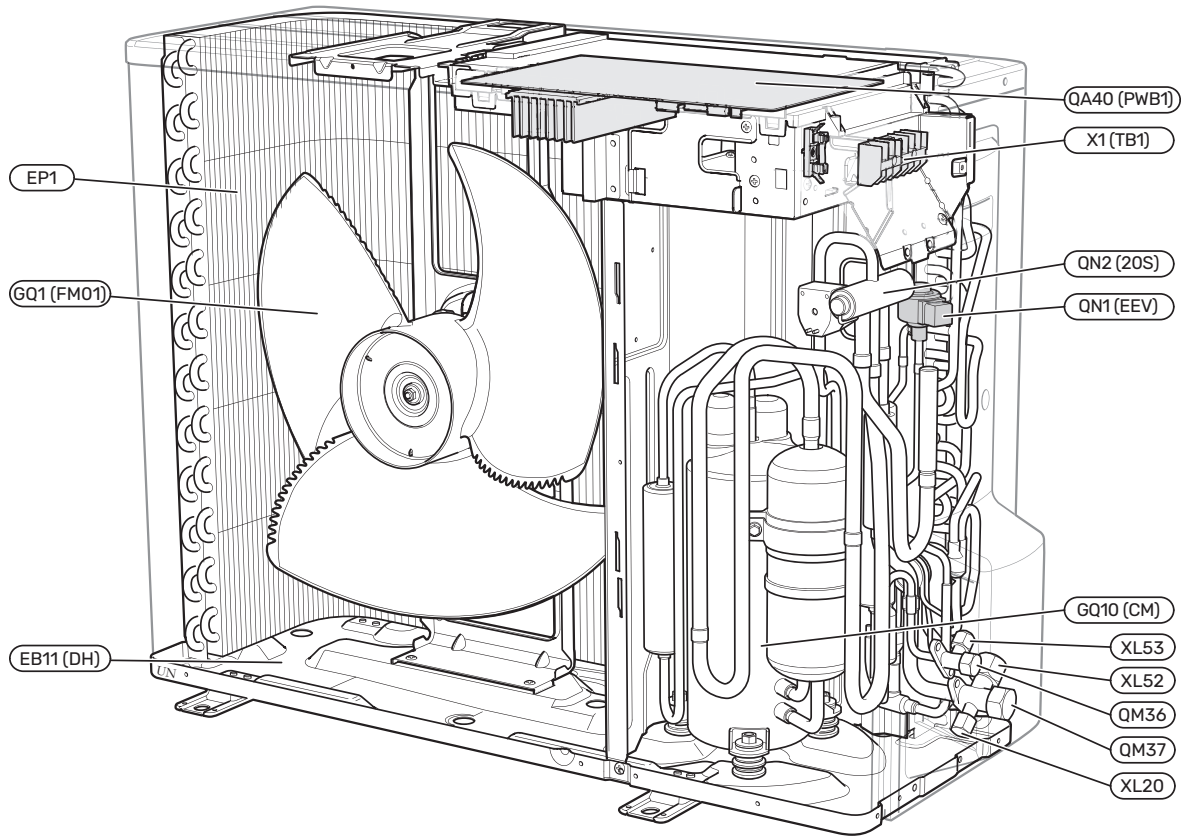

AMS 20-10

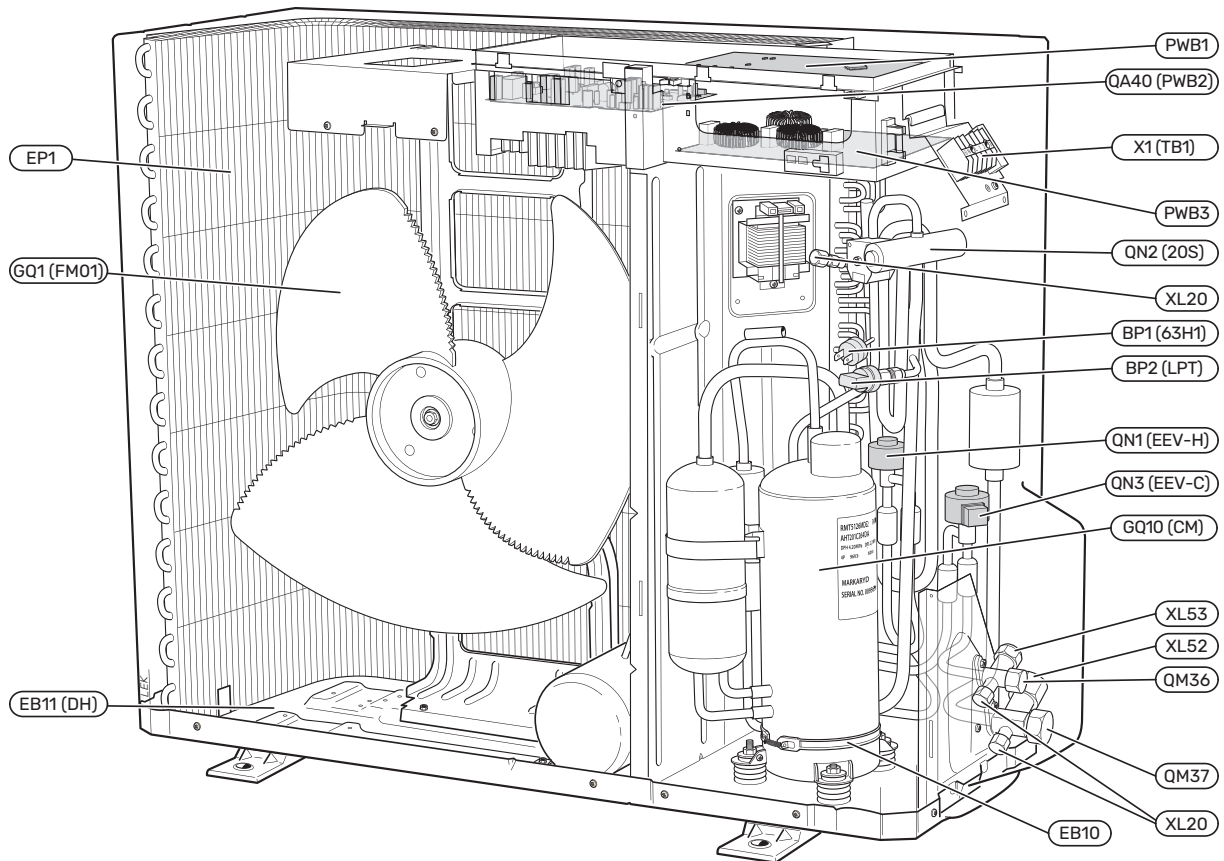

Pipe connections

| | |
|------|-----------------------------------|
| XL20 | Service connection, high pressure |
| XL52 | Gas line connection |
| XL53 | Liquid line connection |

Sensors etc.

| | |
|------------|----------------------|
| BP1 (63H1) | High pressure switch |
|------------|----------------------|

Electrical components

| | |
|-------------|---|
| EB10 (CH) | Compressor heater |
| EB11 (DH) | Condensation water trough heater |
| GP1 | Circulation pump |
| GQ1 (FM01) | Fan |
| QA40 (PWB1) | Control board with inverter unit |
| QA40 (PWB2) | Inverter module |
| (PWB3) | Filter board |
| X1 (TB) | Terminal block, incoming supply and communication |

Cooling components

| | |
|-------------|-----------------------------|
| EP1 | Evaporator |
| GQ10 (CM) | Compressor |
| QM36 | Shut-off valve, liquid line |
| QM37 | Shut-off valve, gas line |
| QN1 (EEV-H) | Expansion valve, heating |
| QN2 (20S) | Reversing valve |
| QN3 (EEV-C) | Expansion valve, cooling |

Designations within brackets according to the supplier's standard.

SENSOR PLACEMENT AMS 20

Outdoor module AMS 20-6

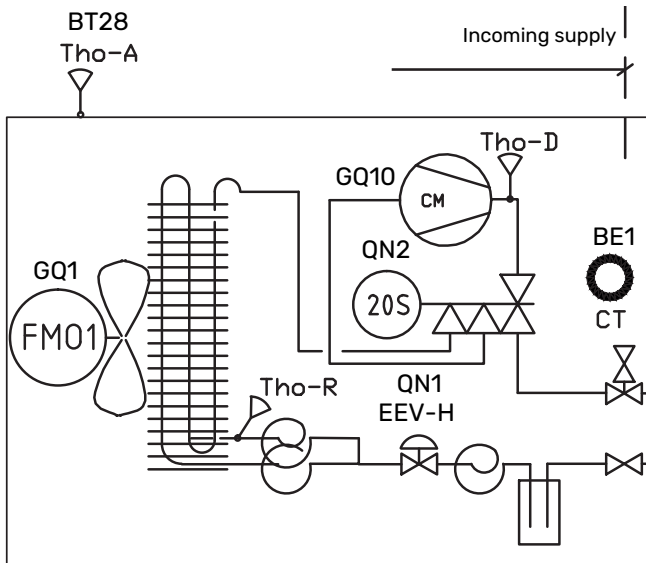

Outdoor module AMS 20-10

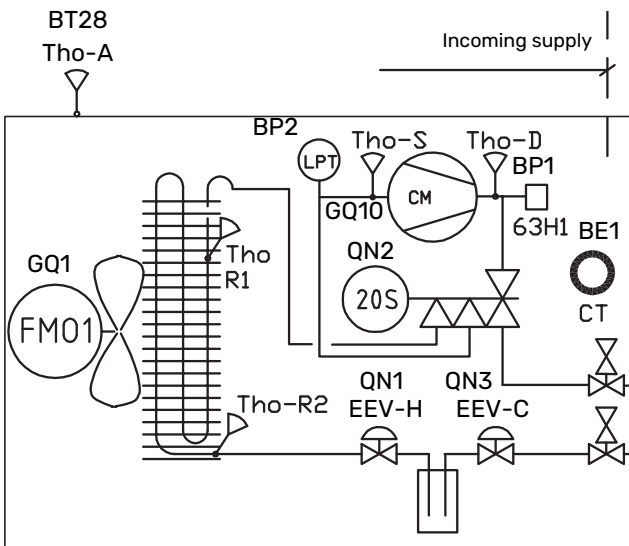

| | |
|--------------|--------------------------|
| BE1 (CT) | Current sensor |
| BT28 (Tho-A) | Ambient sensor |
| BP1 (63H1) | High pressure switch |
| BP2 (LPT) | Low-pressure sensor |
| GQ1 (FM01) | Fan |
| GQ10 (CM) | Compressor |
| QN1 (EEV-H) | Expansion valve, heating |
| QN2 (20S) | Reversing valve |
| QN3 (EEV-C) | Expansion valve, cooling |
| Tho-D | Hot gas sensor |
| Tho-R | Evaporator sensor, out |
| Tho-R2 | Evaporator sensor, in |
| Tho-S | Suction gas sensor |

Designations within brackets according to the supplier's standard.

Pipe connections

General

Pipe installation must be carried out in accordance with current norms and directives.

The system requires the dimensions of the radiator circuit to be designed for a low temperature heating medium. At the lowest dimensioned outdoor temperature (DOT), the highest recommended temperatures are 55 °C on the supply line and 45 °C on the return line, but SVM S332 can handle up to 70 °C.

NOTE!

Ensure that incoming water is clean. When using a private well, it may be necessary to supplement with an extra water filter.



CAUTION!

Any high points in the climate system, must be equipped with air vents.



CAUTION!

The pipe systems need to be flushed out before the indoor module is connected so that any debris cannot damage component parts.



CAUTION!

Water may drip from the safety valve's overflow pipe. The overflow pipe must be routed to a suitable drain, to prevent hot water splashes from causing harm. The overflow pipe must be inclined along its entire length to prevent pockets where water can accumulate, and must be frost-proof. The overflow pipe must be at least the same size as the safety valve. The overflow pipe must be visible and its mouth must be open and not placed close to electrical components.

MINIMUM SYSTEM FLOW DEFROSTING



CAUTION!

An undersized climate system can result in damage to the product and lead to malfunctions.

The dimensions of the pipes between the indoor module and the heat pump should not be less than the recommended pipe diameter. However, each climate system must be dimensioned individually to provide the recommended system flows.

The installation must be dimensioned to provide the minimum defrosting flow at 100 % circulation pump operation.

SYSTEM VOLUME

SVM S332 is equipped with an expansion vessel (CM1).

The volume of the expansion vessel is 13 litres and it is pre-pressurised as standard to 0.5 bar. As a result, the maximum permitted height "H" between the expansion vessel and the highest installed radiator is 5 m, see figure.

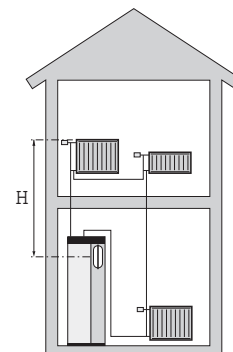

If the pre-pressure is not high enough, it can be increased by filling with air via the valve in the expansion vessel. Any change in the pre-pressure affects the ability of the expansion vessel to handle the expansion of the water.

The maximum system volume, excluding SVM S332, is 60 litres at the above-mentioned pre-pressure.

SYMBOL KEY

| Symbol | Meaning |
|--------|---------------------------------------|
| | Unit box |
| | Shut-off valve |
| | Tapping valve |
| | Non-return valve |
| | Mixing valve |
| | Circulation pump |
| | Immersion heater |
| | Expansion vessel |
| | Filterball |
| | Safety valve |
| | Temperature sensor |
| | Trim valve |
| | Diverter valve/shunt |
| | Heat exchanger |
| | Overflow valve |
| | Indoor module |
| | Air/water heat pump |
| | Domestic hot water |
| | Hot water circulation |
| | Heating system |
| | Heating system with lower temperature |

SYSTEM DIAGRAM

SVM S332 consists of hot water heat exchanger storage tank, hot water expansion vessel, immersion heater, circulation pumps, buffer vessel and control system. SVM S332 connects to the climate system. Hot water is produced via the hot water heat exchanger.

SVM S332 is designed for connection and communication with AMS 20, which together make up a complete heating installation.

When it is cold outdoors, the outdoor unit works with the indoor module, and if the outdoor air temperature falls below the outdoor unit's working range, all heating is performed by the immersion heater¹.

¹ Only SVM S332 3x400 V.

The indoor unit can produce hot water with the integrated immersion heater at the same time as the outdoor unit produces cooling with the compressor.

1x230 V

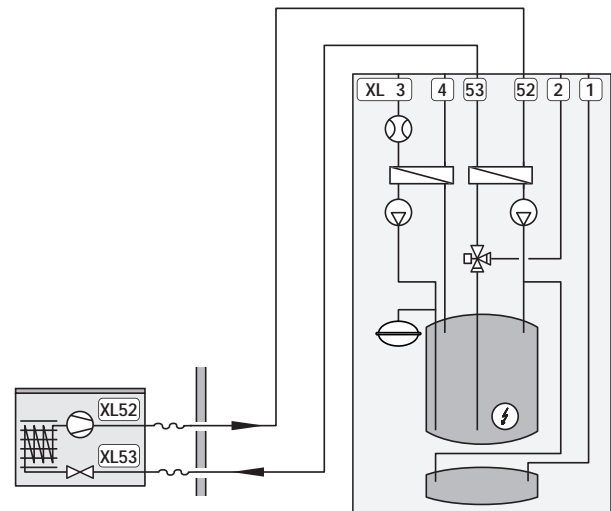

3x400 V

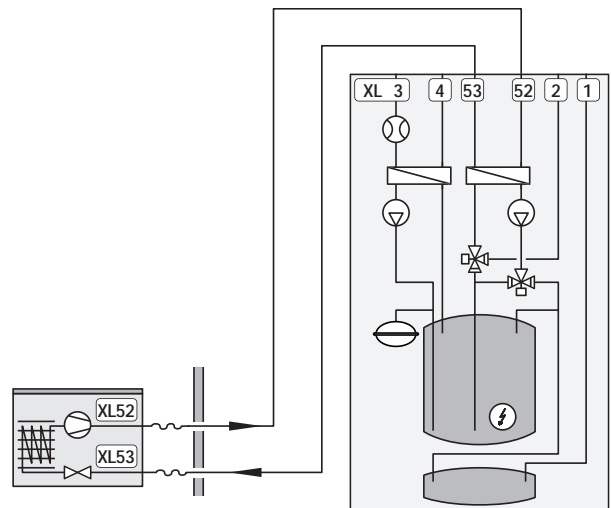

| | |
|------|--|
| XL1 | Connection, heating medium flow line |
| XL2 | Connection, heating medium return line |
| XL3 | Connection, cold water |
| XL4 | Connection, hot water |
| XL52 | Gas line connection |
| XL53 | Liquid line connection |

NOTE!

This is a principle of operation. For more detailed information about SVM S332, see section "The split system's design".

Dimensions and pipe connections

INDOOR MODULE

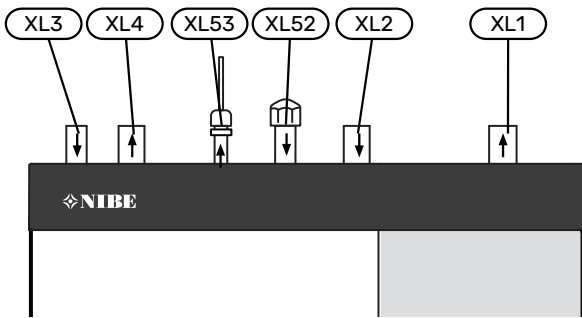

OUTDOOR MODULE

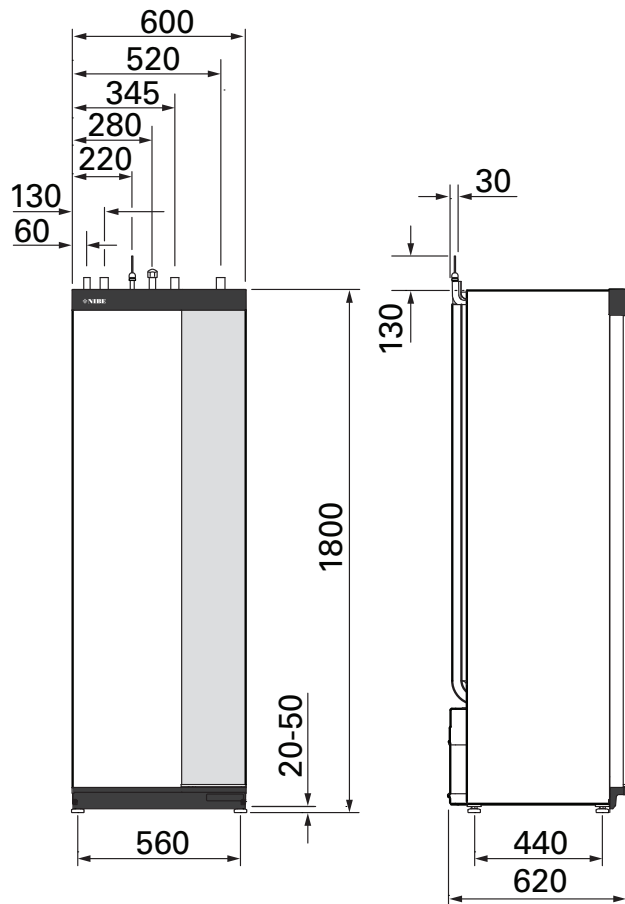
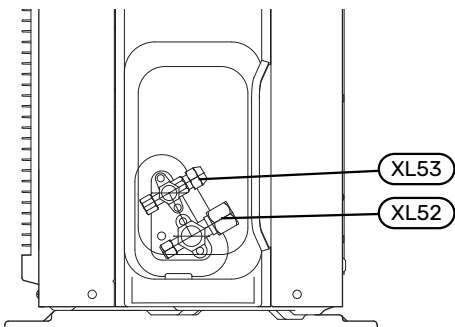

PIPE DIMENSIONS AND MATERIALS

| Connection | | | SVM S332 | |
|------------|--|----|-------------|--------------|
| | | | 6 | 10 |
| XL1/XL2 | Heating medium supply/return \varnothing | mm | 22 (7/8") | |
| XL3/XL4 | Cold/hot water \varnothing | mm | 22 (7/8") | |
| XL52 | Gas line connection, supply, from outdoor unit \varnothing ¹ | mm | 12.7 (1/2") | 15.88 (5/8") |
| XL53 | Liquid line connection, return, to outdoor unit \varnothing ² | mm | 6.35 (1/4") | |

¹ Copper grade SS-EN 12735-1 or C1220T, JIS H3300. Minimum material thickness 1.0 mm.

² Copper grade SS-EN 12735-1 or C1220T, JIS H3300. Minimum material thickness

0.8 mm.

Connection of outdoor unit

Install refrigerant pipes between the outdoor unit and indoor unit.

LIMITATIONS, OUTDOOR UNIT

| | | SVM S332 | |
|---|---|----------|----|
| | | 6 | 10 |
| Max. length, refrigerant pipe, one-way ¹ | m | 30 | 50 |
| Max height difference, when SVM S332 is placed higher than outdoor unit | m | 20 | 15 |
| Max height difference, when SVM S332 is placed lower than outdoor unit | m | 20 | 30 |

¹ If the length of the refrigerant pipes exceeds 15 metres, extra refrigerant must be added at 0.02 kg/m.

PIPE CONNECTION, REFRIGERANT PIPE

- Carry out the pipe installation, on the refrigerant side between the outdoor unit (AMS 20) and the indoor module (SVM S332), with the shut-off valves (QM36, QM37) closed.
- Connect refrigerant pipes between the shut-off valves (QM36 and QM37) on the outdoor unit (AMS 20) and the connections (XL52 and XL53) on the indoor module (SVM S332).
- Ensure that water or dirt does not enter the pipes.
- Bend the pipes with as large a radius as possible (at least 4 times the pipe diameter). Do not bend a pipe repeatedly. Use a bending tool.
- Connect the flare connector and tighten to the following torque. Use the "Tightening angle" if a torque wrench is not available.

| Outer diameter, copper pipe (mm) | Tightening torque (Nm) | Tightening angle (°) | Recommended tool length (mm) |
|----------------------------------|------------------------|----------------------|------------------------------|
| Ø6.35 (1/4") | 14-18 | 45-60 | 150 |
| Ø9.52 (3/8") | 34-42 | 30-45 | 200 |
| Ø12.7 (1/2") | 49-61 | 30-45 | 250 |
| Ø15.88 (5/8") | 68-82 | 15-20 | 300 |

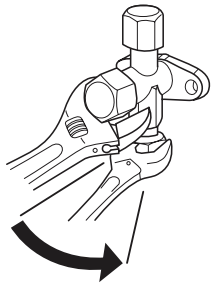

CAUTION!

Gas shielding must be used when soldering.

Flare connections

Expansion:

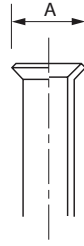

| Outer diameter, copper pipe (mm) | A (mm) |
|----------------------------------|--------|
| Ø6.35 (1/4") | 9.1 |
| Ø9.52 (3/8") | 13.2 |
| Ø12.7 (1/2") | 16.6 |
| Ø15.88 (5/8") | 19.7 |

Ejection:

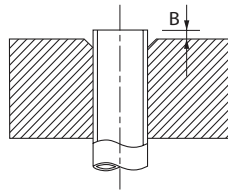

| Outer diameter, copper pipe (mm) | B, with a R32/410A tool (mm) | B, with a conventional tool (mm) |
|----------------------------------|------------------------------|----------------------------------|
| Ø6.35 (1/4") | 0.0-0.5 | 1.0-1.5 |
| Ø9.52 (3/8") | 0.0-0.5 | 0.7-1.3 |
| Ø12.7 (1/2") | 0.0-0.5 | 1.0-1.5 |
| Ø15.88 (5/8") | 0.0-0.5 | 0.7-1.3 |

(Follow instructions for the tool used.)

Use without outdoor unit

The indoor module can be used without an outdoor unit, i.e. solely as an electric boiler, to produce heat² and hot water, for example before the outdoor unit is installed.

In order to use the indoor module alone, you need to adjust the software settings according to section "Commissioning without outdoor unit".

Climate system

A climate system is a system that regulates the indoor temperature with the help of the control system in SVM S332 and, for example, radiators, underfloor heating, underfloor cooling, fan coils, etc.

CONNECTING THE CLIMATE SYSTEM

Install as follows:

- enclosed combined safety valve (FL2) / pressure gauge (BP5)
- enclosed filterball (QZ2.2)

Install the filterball as close to SVM S332 as possible. The filterball must be accessible for cleaning the filter and magnet.

- shut-off valve

Install the shut-off valve as close to SVM S332 as possible.

- When connecting to a system with thermostats, either a bypass valve must be fitted or, alternatively, some of the thermostats must be removed to ensure there is sufficient flow and heat emission.

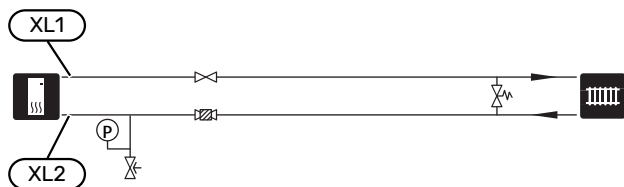

² Only SVM S332 3x400 V with shunt valve QN11.

COOLING

Cooling is produced by the outdoor unit and then passes through the indoor module and is distributed in the property using, for example, fan coils or under floor cooling.

Condensation insulation

Effective insulation of cold pipes (down to 7 °C) requires the installation of insulation and vapour barriers, in order to avoid energy losses and the risk of damage to surrounding parts of the building or other problems due to condensation.

Take the necessary steps (e.g. adapt the supply temperature according to the property's conditions) to ensure that any condensation does not give rise to moisture damage in the property.

Heating and cooling in the same system

In installations where heat and cooling can be required at different times, heat and cooling can be distributed via the same climate system.

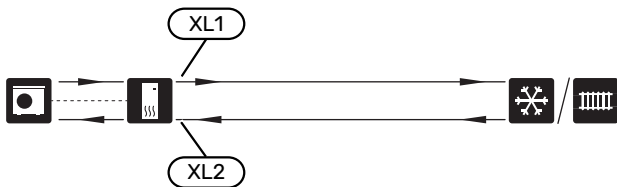

Separate systems for heating and cooling with shut-off valve

In installations where some climate systems are not protected against condensation, the flow to these climate systems can be shut off with a shut-off valve (QM31) during cooling operation.

1. Connect in the shut-off valve to the AUX output in SVM S332.
2. In menu 7.4 - "Selectable in/outputs" select "Cooling mode indication".

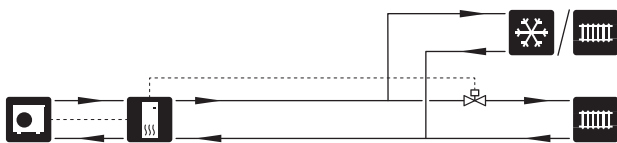

Separate systems for heating and cooling with diverter valve

In installations where you want to heat and cool in separate climate systems, e.g. heating via under floor heating and cooling via fan coils, a diverter valve (QN12) is installed.

1. Connect the diverter valve on the AUX output in SVM S332.
2. In menu 7.4 - "Selectable in/outputs" select "Cooling mode indication".

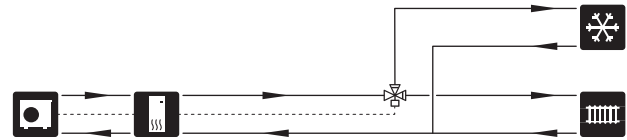

Cold and hot water

The settings for hot water are made in menu 7.1.1 - "Hot water".

CONNECTING COLD AND HOT WATER

Install as follows:

- non-return valve

- enclosed filterball (QZ2.1)

Install the filterball as close to SVM S332 as possible.

- pressure relief valve

The safety valve must have an opening pressure of max. 1.0 MPa (10.0 bar).

- mixing valve

A mixer valve must also be installed, if the factory setting for hot water is changed. National regulations must be observed.

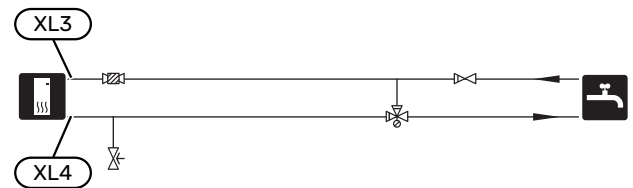

Installation alternative

SVM S332 can be installed in several different ways, some of which are shown here.

Further option information is available at nibe.eu and in the respective assembly instructions for the accessories used. See page 78 for a list of the accessories that can be used with SVM S332.

EXTRA CLIMATE SYSTEM

In buildings with several climate systems that require different supply temperatures, the accessory ECS 40/ECS 41 can be connected.

A shunt valve then lowers the temperature to the underfloor heating system, for example.

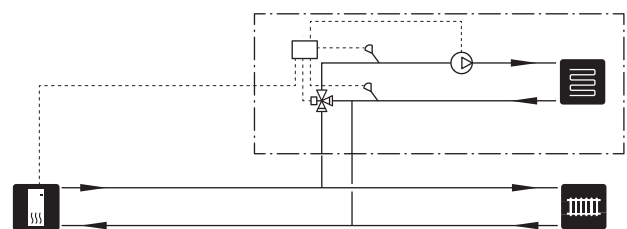

EXTRA HOT WATER HEATERS

The system should be supplemented with an extra water heater, if a large bath tub or other significant consumer of hot water is installed.

Water heater with immersion heater

In a water heater with an immersion heater, the water is initially heated by the heat pump. The immersion heater in the water heater is used for keeping warm and when the heat pump does not have sufficient power.

The water heater's flow is connected after SVM S332.

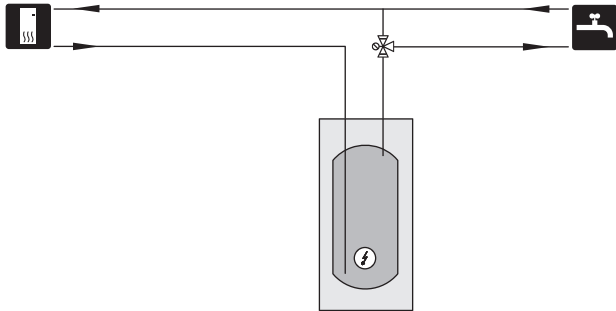

HOT WATER CIRCULATION

A circulation pump can be controlled by SVM S332 to circulate the hot water. The circulating water must have a temperature that prevents bacterial growth and scalding, and national standards must be satisfied.

The HWC return is connected to a freestanding water heater.

The circulation pump is activated via the AUX output in menu 7.4 - "Selectable in/outputs".

HWC can be supplemented with a hot water sensor for HWC (BT70) and (BT82), which is connected via the AUX input and activated in menu 7.4 - "Selectable in/outputs".

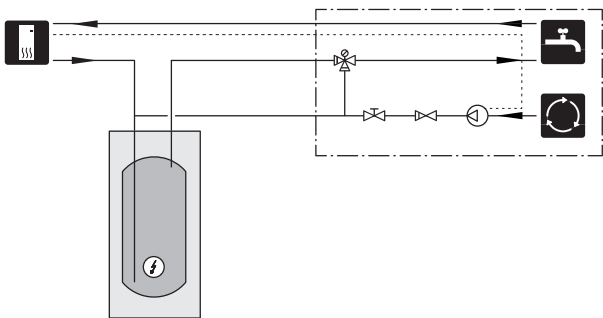

DELAYED SUPPLY LINE FOR COOLING

When the installation switches to cooling production e.g. from hot water production, a certain amount of heat escapes into the cooling system. To avoid this, a diverter valve is installed (QN44) in the system.

Via the diverter valve, the supply line circulates back to the indoor unit until the temperature in the charge circuit starts to approach the desired supply temperature, at which point the valve switches to the climate system. The temperature is measured with an internal sensor in the outdoor unit, no additional sensor is needed.

The diverter valve is activated via the AUX output in menu 7.4 - "Selectable in/outputs", "Cool. mode ind. w delay".

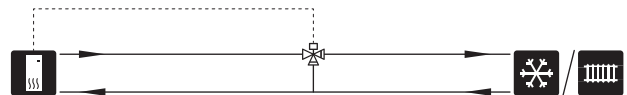

Electrical connections

General

All electrical equipment, except the outdoor sensors, room sensors and the current sensors are ready connected at the factory.

- Electrical installation and wiring must be carried out in accordance with national provisions.
- Prior to insulation testing the house wiring, disconnect the air/water heat pump installation.
- If the property has residual current devices (RCDs) NIBE SPLIT should be equipped with two separate RCDs, one for the outdoor unit and one for the indoor unit.
- NIBE SPLIT must be installed via isolator switches, one for the outdoor unit and one for the indoor unit. The cable area must be dimensioned based on the fuse rating used.
- If a miniature circuit breaker is used, this must have at least triggering characteristic "C". See section "Technical specifications" for fuse size.
- Use a screened cable for communication with the outdoor unit.
- To prevent interference, communication cables to external connections must not be laid in the vicinity of high voltage cables.
- The minimum area of communication and sensor cables to external connections must be 0.5 mm² up to 50 m, for example EKKX, LIYY or equivalent.
- For an electrical wiring diagram for NIBE SPLIT, see the "Technical specifications" section.
- When routing a cable into SVM S332, the cable grommets (UB1-UB4) must be used.

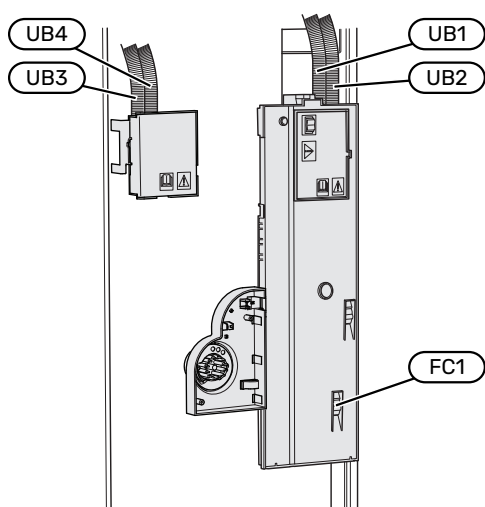

When routing a cable into AMS 20, the cable holder (UB1) must be used.

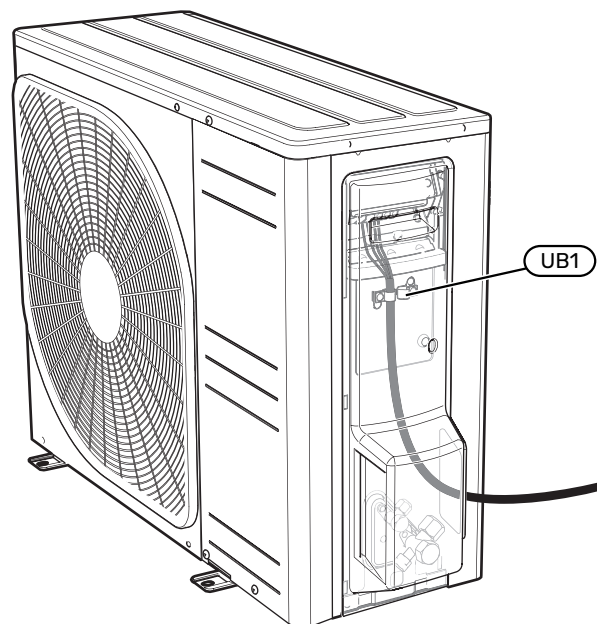

CAUTION!

Electrical installation and any servicing must be carried out under the supervision of a qualified electrician. Turn off the power with the circuit breaker before servicing.



CAUTION!

If the supply cable is damaged, only NIBE, its service representative or similar authorised person may replace it to prevent any danger and damage.



CAUTION!

To prevent damage to the installation's electronics, check the connections, main voltage and phase voltage before NIBE SPLIT is started.



CAUTION!

Do not start the system before filling up with water. Components in the system could be damaged.

MINIATURE CIRCUIT-BREAKER

The operating circuit in SVM S332 and some of its internal components are fused internally by a miniature circuit-breaker (FC1).

Only SVM S332 1x230 V.

ACCESSIBILITY, ELECTRICAL CONNECTION

Removing the cover

The hatch is opened using a screwdriver.

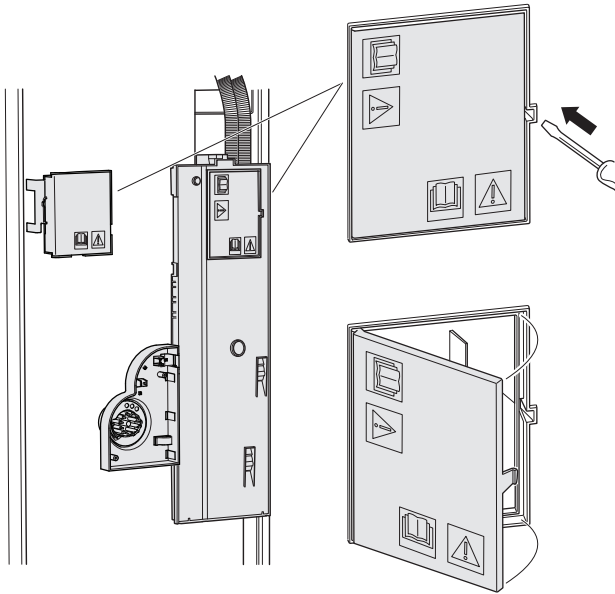

Removing the covers

The cover is opened using a screwdriver.

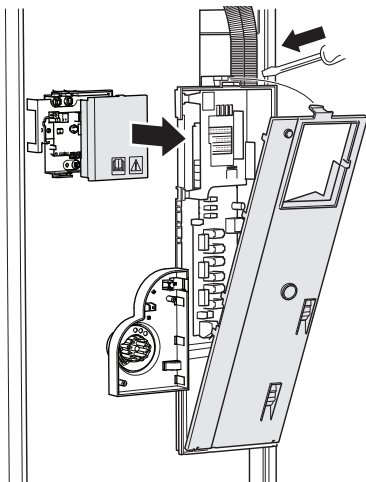

CABLE LOCK

Use a suitable tool to release/lock cables in the indoor module terminal blocks.

Terminal block

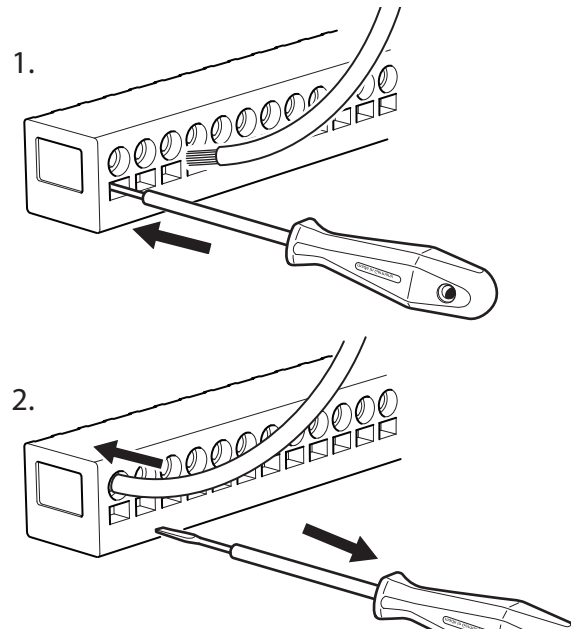

TEMPERATURE LIMITER

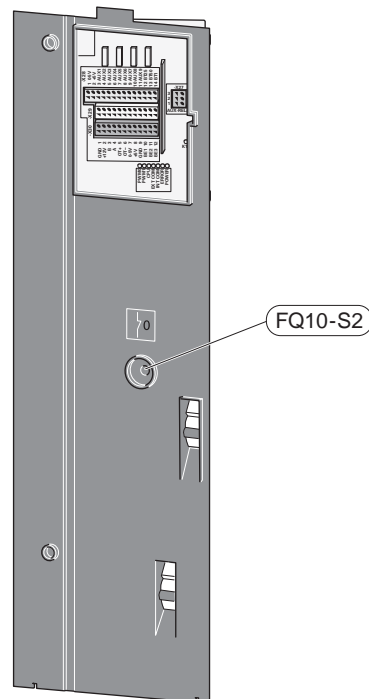

The temperature limiter (FQ10) cuts the voltage to the electric additional heat if the temperature rises above 89 °C and it is reset manually.

Resetting

The temperature limiter (FQ10) is accessed behind the front cover. Reset the temperature limiter by pressing its button (FQ10-S2).

Connections

TERMINAL BLOCKS SVM S332

The following terminal blocks are used on the base board (AA2).

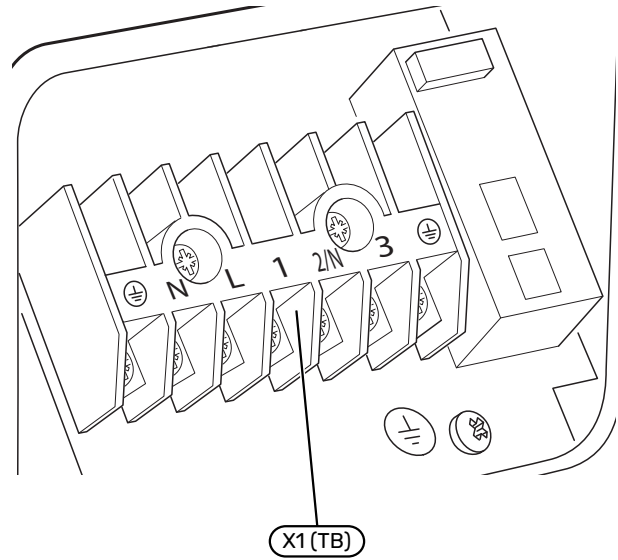
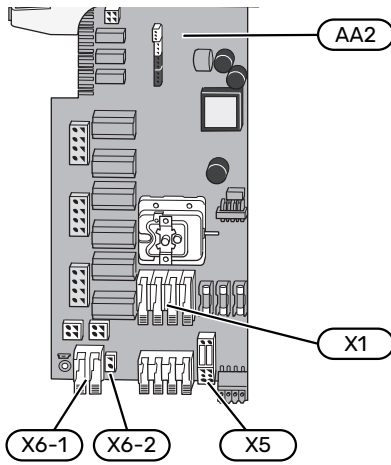

The following terminal blocks are used on the communication board (AA23).

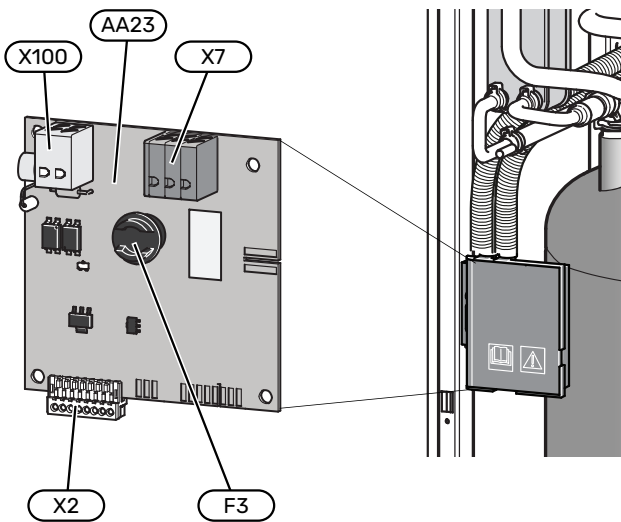

TERMINAL BLOCK AMS 20

The following terminal block is used as a terminal block for power supply and communication X1 (TB).

POWER CONNECTION SVM S332

Supply voltage

Enclosed cable for incoming supply electricity is connected to terminal block X1 and X6-1 on the PCB (AA2).

Connection 1x230 V Connection 3x400 V

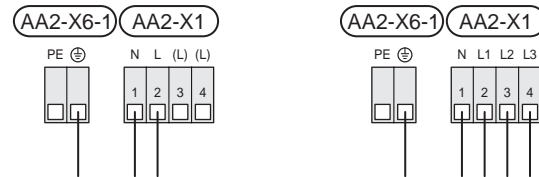

External control voltage for the control system

If the control system will be powered separately from other components in the indoor module (e.g. for tariff control), a separate operating cable must be connected.



CAUTION!

During service, all supply circuits must be disconnected.

1. Remove the bridges from terminal block AA2-X5.

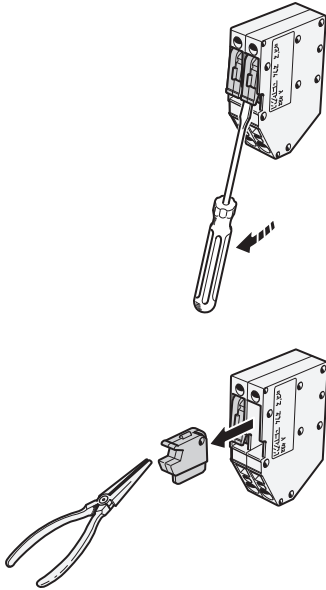

2. Connect control voltage (230 V ~ 50Hz) to AA2-X5:N, AA2-X5:L and AA2-X6-2 (PE).

Enclosed label

The enclosed label is placed on the electrical connection's cover.

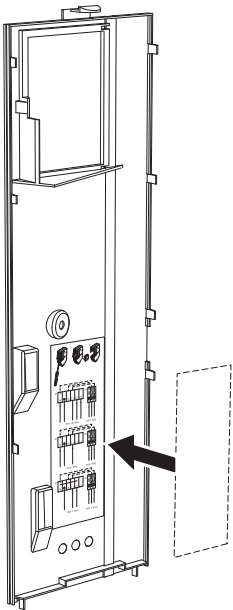

Tariff control

If the voltage to the immersion heater is lost for some time, "Tariff blocking" must be selected at the same time via the selectable inputs, see section "Selectable inputs".

POWER CONNECTION AMS 20

Connect the cable for the external supply to terminal block X1 (TB).

Connection 1 x 230 V

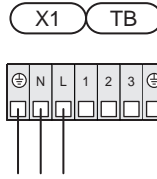

EXTERNAL CONNECTIONS

Connect external connections on terminal blocks X28, X29 and X30 on the base board (AA2).

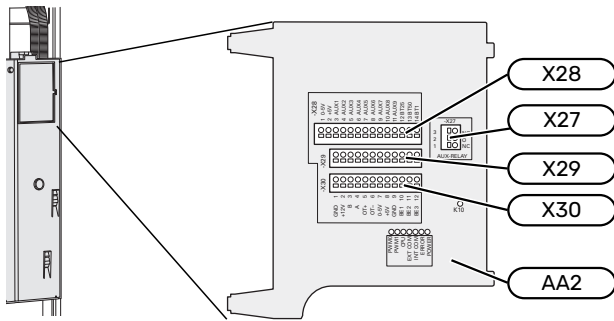

Sensors

Outside sensor

The outdoor temperature sensor (BT1) is placed in the shade on a wall facing north or north-west, so it is unaffected, for example, by the morning sun.

Connect the outdoor temperature sensor to terminal block AA2-X28:14 and AA2-X29:GND.

If a conduit is used it must be sealed to prevent condensation in the sensor capsule.

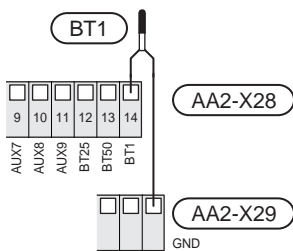

External supply temperature sensor

If an external supply temperature sensor (BT25) needs to be used, connect it to terminal block AA2-X28:12 and to terminal block AA2-X29:GND.

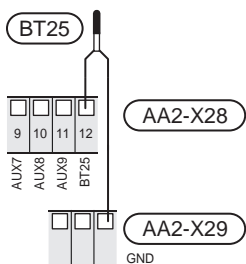

Room sensor

SVM S332 is supplied with an enclosed room sensor (BT50) that makes it possible to display and control the room temperature in the display on SVM S332.

SVM S332 operates without the room sensor, but if you want to read the property's indoor temperature from the display on SVM S332, the room temperature sensor must be fitted.

The room temperature sensor is installed in a neutral location where the set temperature is required. A suitable location might be, for example, on a free inner wall in a hall approx. 1.5 m above the floor. It is important that the room temper-

ature sensor is not prevented from measuring the correct room temperature, for example by being located in a recess, between shelves, behind a curtain, above or close to a heat source, in a draught from an external door or in direct sunlight. Closed radiator thermostats can also cause problems.

Connect the room temperature sensor to terminal blocks X28:13 and AA2-X29:GND.

If a room sensor is to be used to change the room temperature in °C and/or to fine-tune the room temperature, the sensor must be activated in menu 1.3 - "Room sensor settings".

If a room sensor is used in a room with underfloor heating, it should only have an indicative function, not control of the room temperature.

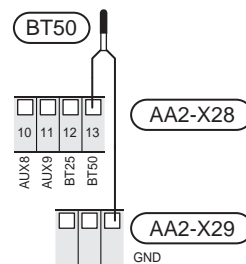

NOTE!

Changes of temperature in the property take a long time. For example, short periods of time combined with under floor heating will not give a noticeable difference in room temperature.

Pulse energy meter

Up to two electricity meters or energy meters for heating (BE6, BE7) can be connected to SVM S332 via terminal blocks AA2-X28:1-2 and AA2-X30:7-8.

NOTE!

The EMK accessory is connected to the same terminal blocks as electricity meters/energy meters.

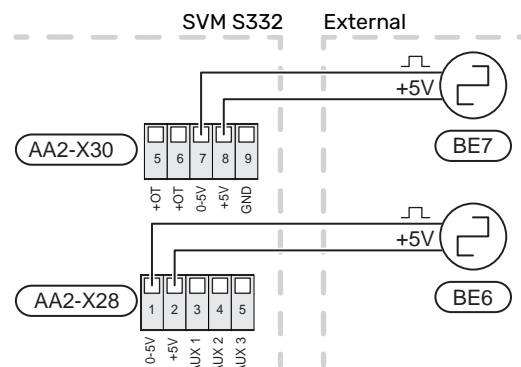

Activate the meter(s) in menu 7.2 - "Accessory settings" and then set the desired value ("Energy per pulse" or "Pulses per kWh") in menu 7.2.19 - "Pulse energy meter".

Load monitor

Integrated load monitor

SVM S332 is equipped with a simple form of integrated load monitor, which limits the power steps for the electric additional heat by calculating whether future power steps can be connected to the relevant phase without exceeding the current for the specified main fuse.

If the current would exceed the specified main fuse, the power step is not permitted. The size of the property's main fuse is specified in menu 7.1.9 - "Load monitor".

Load monitor with current sensor

When many power-consuming products are connected in the property at the same time as the compressor and/or the electric additional heat is operating, there is a risk of the property's main fuses tripping.

SVM S332 is equipped with a load monitor that, with the help of a current sensor, controls the power steps for the electric additional heat by redistributing the power between the different phases or, alternatively, disengages the electric additional heat step-by-step if there is an overload in a phase.

If the overload remains despite the electric additional heat being disengaged, the compressor is limited.

Reconnection occurs when the other current consumption is reduced.

The building's phases can have different loads. If the compressor has been connected to a heavily loaded phase, there is a risk that the compressor output will be restricted and the electric additional heat will operate longer than expected. This means that the savings will not be as expected.

Connection and activation of current sensors

1. Install a current sensor on each incoming phase conductor into the electrical distribution unit. This is best done in the electrical distribution unit.
2. Connect the current sensors to a multi-core cable in an enclosure directly adjacent to the electrical distribution unit. The multi-core cable between the enclosure and SVM S332 must have a cable area of at least 0.5 mm².

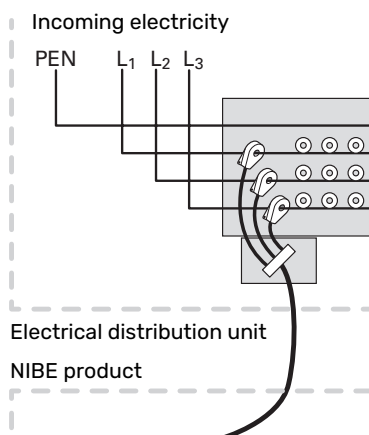

3. Connect the cable to terminal block AA2-X30:9-12, where X30:9 is the common terminal block for the three current sensors.

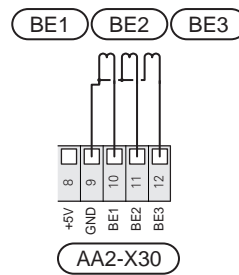

4. Specify the size of the property's main fuse in menu 7.1.9 - "Load monitor".
5. Activate phase detection in menu 7.1.9 - "Load monitor". Read more about phase detection in section "Menu 7.1.9 - Load monitor".

External heating cable KVR 12 (Accessory)

SVM S332 is equipped with a terminal block for external heating cable (EB14, not enclosed). The connection is fused for a 3-metre cable length with 250 mA (F3 on communication board AA23). If a different cable length is to be used, the fuse must be replaced in accordance with table.



CAUTION!

Self regulating heating cables must not be connected.

| Length (m) | Total power (W) | Fuse (F3) | NIBE Part no. Fuse |
|------------|-----------------|-------------|--------------------|
| 1 | 15 | T100mA/250V | 718 085** |
| 3 | 45 | T250mA/250V | 518 900* |
| 6 | 90 | T500mA/250V | 718 086** |

*Fitted at the factory.

**Enclosed with the accessory KVR 12.

Connect the heating cable to terminal block PE, N and L in the enclosed electrical distribution box. Connect supply voltage from SVM S332 AA23-X7 to terminal block 1/2, N and PE. See following image:

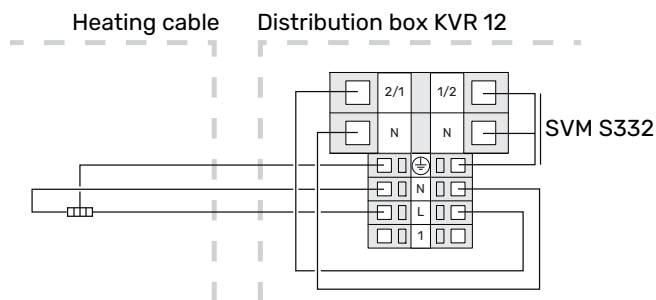

CAUTION!

The pipe must be able to withstand the heat from the heating cable.

To guarantee the function, the accessory KVR 12 should be used. See instructions in the Installer Manual for KVR 12.

COMMUNICATION

Communication connection AMS 20

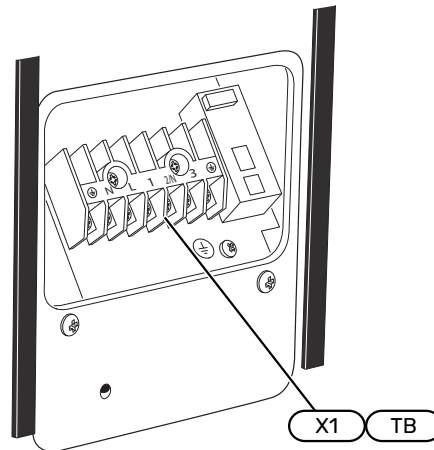

Communication is connected on terminal block X1(TB).

Air/water heat pump

The outdoor unit is connected to terminal block AA23-X100:1-2.

Indoor module

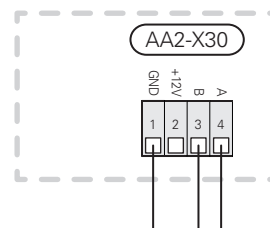

More information about connection can be found in the air-to-water heat pump's Installer Manual.

Connecting accessories

Instructions for connecting accessories are provided in the manual accompanying the accessory. See section "Accessories" for a list of the accessories that can be used with SVM S332. Connection for communication with the most common accessories is shown here.

Accessories with accessory board (AA5)

Accessories with accessory board (AA5) connect to terminal block AA2-X30:1, 3, 4 in SVM S332.

If several accessories are to be connected, or are already installed, the boards are connected in series.

Because there can be different connections for accessories with accessory board (AA5), you should always read the instructions in the manual for the accessory that is to be installed.

SVM S332

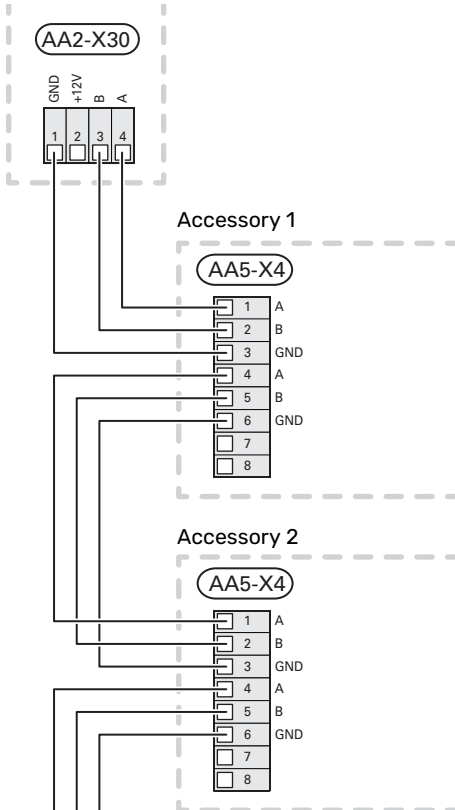

Network cable for myUplink (W130)

In instances when you want to connect to myUplink using a network cable instead of via wifi.

1. Connect the shielded network cable to the display.
2. Route the network cable to the top of SVM S332.

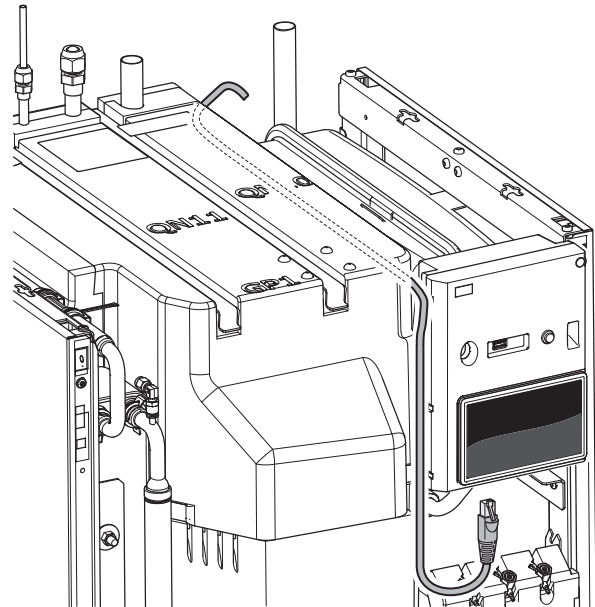

SELECTABLE IN/OUTPUTS

SVM S332 has software-controlled AUX inputs and outputs for connecting the external switch function (contact has to be potential-free) or sensor.

In menu 7.4 - "Selectable in/outputs", you select the AUX connection to which each function has been connected.

For certain functions, accessories may be required.



TIP!

Some of the following functions can also be activated and scheduled via menu settings.

Selectable inputs

Selectable inputs on the base board (AA2) for these functions are AA2-X28:3-11. Each function connects to any input and GND (AA2-X29).

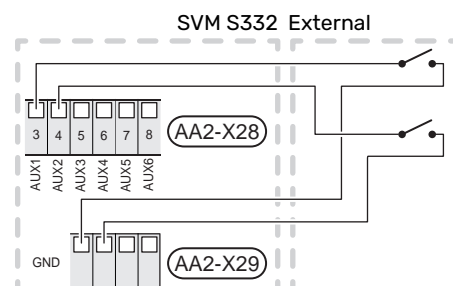

The example above uses the inputs AUX1 (AA2-X28:3) and AUX2 (AA2-X28:4).

Selectable output

A selectable output is AA2-X27.

The output is a potential-free switching relay.

Alarm indication is connected to C-NC, other functions are connected to C-NO.

If SVM S332 is switched off or in emergency mode, the relay is in C-NC position.

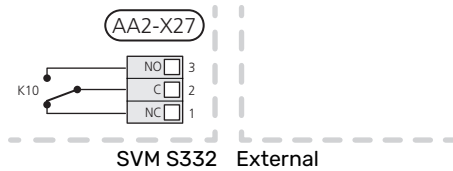

NOTE!

The relay output may be subjected to a max load of 2 A at resistive load (230 V~).

TIP!

The AXC accessory is required if more than one function is to be connected to the AUX output.

Possible selection for AUX inputs

Temperature sensor

Available options are:

- Cool/ht sensor (BT74), determines when it is time to switch between cooling, heating and hot water mode.
- Ext. HW out temp. (BT70) (displayed hot water sensor for HWC. Placed on the supply line.)
Can be selected when "HW circulation" is activated in menu 7.4 - "Selectable in/outputs".
- Ext. HW recirc. temp. (BT82) (displayed hot water sensor for HWC. Placed on the return line.)
Can be selected when "HW circulation" is activated in menu 7.4 - "Selectable in/outputs".
- 6 dedicated sensors (BT37.1 – BT37.6) for optional placement and naming.

Monitor

Available options are:

- External alarm (NO), External alarm (NC)
The alarm is connected to the control, which means that the malfunction is presented as an information message in the display.
- Stove monitor. To the ERS HRV unit.
A stove monitor is a thermostat that is connected to the chimney. If the negative pressure is too low, the fans in ERS (NC) are closed.

External activation of functions

An external switch function can be connected to SVM S332 to activate various functions. The function is activated during the time the switch is closed.

Possible functions that can be activated:

- Temp. more hot water
- Act. dmnd. mode small
- "External adjustment"

When the switch is closed, the temperature is changed in °C (if a room sensor is connected and activated). If a room sensor is not connected or not activated, the desired change of "Temperature" ("Offset") is set with the number of steps selected. The value is adjustable between -10 and +10. Setting the value for the change is performed in menu 1.30.3 - "External adjustment".

- activation of one of four fan speeds.

(Can be selected if ventilation accessory is activated.)

The following options are available:

- "Activate fan speed 1 (NO)" - "Activate fan speed 4 (NO)"
- "Activate fan speed 1 (NC)"

The fan speed is activated during the time the switch is closed. Normal speed is resumed when the switch is opened again.

- SG ready

NOTE!

"SG Ready" requires two AUX inputs.

In cases where this function is required, it must be connected to terminal block X28 on the base board (AA2).

"SG Ready" is a smart form of tariff control where your electricity supplier can affect the indoor and hot water temperatures or simply block the additional heating and/or the compressor in the heat pump at certain times of the day (can be selected in menu 4.2.3 after the function is activated). Activate the function by connecting potential-free switch functions to two inputs selected in menu 7.4 - "Selectable in/outputs" (SG Ready A and SG Ready B).

Closed or open switch means one of the following:

- *Blocking (A: Closed, B: Open)*

"SG Ready" is active. The compressor in the outdoor unit and additional heating are blocked.

- *Normal mode (A: Open, B: Open)*

"SG Ready" is not active. No effect on the system.

- *Low price mode (A: Open, B: Closed)*

"SG Ready" is active. The system focuses on costs savings and can for example exploit a low tariff from the electricity supplier or over-capacity from any own power source (effect on the system can be adjusted in the menu 4.2.3).

- Overcapacity mode (A: Closed, B: Closed)

"SG Ready" is active. The system is permitted to run at full capacity at over capacity (very low price) with the electricity supplier (effect on the system is settable in menu 4.2.3).

(A = SG Ready A, B = SG Ready B)

External blocking of functions

An external switch function can be connected to SVM S332 for blocking various functions. The switch must be potential-free and a closed switch results in blocking.



CAUTION!

Blocking entails a risk of freezing.

Functions that can be blocked:

- Block heating
- Block hot water (any hot water circulation (HWC) remains in operation)
- Block (EB101) (outdoor unit (EZ101))
- Block additional heat
- Tariff blocking (NO), Tariff blocking (NC) (additional heat, compressor, heating, cooling and hot water are disconnected)
- "External power limiting"

For markets where the mains network operator requires dynamic control of the mains network's load, the compressor's and the immersion heater's operating power can be limited.

You set the power limit in menu 7.4.2 - "External power limiting".

Possible selections for AUX output

Indications

- Alarm outp.
- Group alarm
- Cooling mode indication
- Cool. mode ind. w delay
- Holiday
- Away mode
- SPA (Smart Price Adaption: low electricity price)

Control

- HW circulation (circulation pump for hot water circulation)
- Ext. HM pump (external heating medium pump)



CAUTION!

The relevant distribution box must be marked with a warning about external voltage.

Connecting external circulation pump

An external circulation pump is connected to the AUX output, as illustrated below.

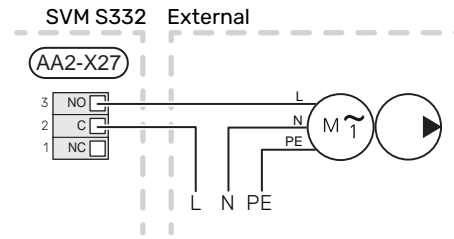

Settings

ELECTRICAL ADDITION - MAXIMUM OUTPUT

The immersion heater is set at the factory to max power.

The immersion heater's power is set in menu 7.1.5.1 - "Int elec add heat".

Power steps of the immersion heater

The table(s) displays the total phase current for the immersion heater.

1x230 V

| Electrical addition (kW) | Max L1 (A) |
|--------------------------|------------|
| 0 | 0.0 |
| 1 | 4.3 |
| 2 | 8.7 |
| 3 | 13.0 |
| 4 | 17.4 |
| 5 | 21.7 |
| 6 | 26.1 |
| 7 ¹ | 30.4 |

¹ Factory setting

3x400 V

| Electrical addition (kW) | Max L1 (A) | Max L2 (A) | Max L3 (A) | N (A) |
|--------------------------|------------|------------|------------|-------|
| 0 | 0.0 | 0.0 | 0.0 | 0.0 |
| 1 | 0.0 | 4.3 | 0.0 | 4.3 |
| 2 | 0.0 | 0.0 | 8.7 | 8.7 |
| 3 | 0.0 | 4.3 | 8.7 | 7.5 |
| 4 | 0.0 | 8.7 | 8.7 | 8.7 |
| 5 | 4.3 | 8.7 | 8.7 | 4.3 |
| 6 | 8.7 | 8.7 | 8.7 | 0.0 |
| 7 | 8.7 | 8.7 | 13.0 | 4.3 |
| 8 | 8.7 | 13.0 | 13.0 | 4.3 |
| 9 ¹ | 13.0 | 13.0 | 13.0 | 0.0 |

¹ Factory setting

Current sensor

When the current sensors are connected, SVM S332 monitors the phase currents and allocates the power steps automatically to the least loaded phase.



CAUTION!

If the current sensors are not connected, SVM S332 calculates how high the currents will be if the relevant power steps are added. If the currents are higher than the set fuse size, the power step is not allowed to cut in.

EMERGENCY MODE

Emergency mode is used in event of operational interference and in conjunction with service.

When SVM S332 is put into emergency mode, the system works as follows:

- The compressor is blocked.
- SVM S332 prioritises heating production³.
- Hot water is produced if possible.
- The load monitor is not active.
- Max output for the immersion heater in emergency mode, limited according to the setting in menu 7.1.8.2 - "Emergency mode".
- Fixed supply temperature if the system has no value from the outdoor temperature sensor (BT1).

When the emergency mode is active, the status lamp is yellow.

You can activate the emergency mode both when SVM S332 is running and when it is switched off.

To activate when SVM S332 is running: press and hold the on/off button (SF1) for 2 seconds and select "Emergency mode" from the shutdown menu.

To activate emergency mode when SVM S332 is switched off: press and hold the on/off button (SF1) for 5 seconds. (Deactivate the emergency mode by pressing once).

SINGLE PHASE COMPRESSOR

AMS 20 is equipped with a single phase compressor. This means that one of the phases will be loaded with a number of amperes (A) during compressor operation. Check the maximum load in the table below.

| Outdoor module | Maximum current (A) |
|----------------|---------------------|
| AMS 20-6 | 15 |
| AMS 20-10 | 16 |

Maximum permitted phase loading can be restricted to a lower maximum current in the indoor unit.

³ Only SVM S332 3x400 V with shunt valve QN11.

Commissioning and adjusting

Compressor heater

AMS 20 is equipped with a compressor heater (EB10) (CH) that heats the compressor when it is cold and at start-up. (Does not apply to AMS 20-6.)



CAUTION!

The compressor heater must have been active for 6 – 8 hours before the first start.

Preparations

1. Check that the externally mounted filling valves are fully closed.
2. Check that SVM S332 is closed.
3. Check the miniature circuit-breaker (FC1)⁴. It may have tripped during transport.
4. Check that the draining valve (QM1) is fully closed and that the temperature limiter (FQ10) has not tripped. See section "Temperature limiter".

⁴ Only SVM S332 1x230 V.

Filling and venting

FILLING THE HOT WATER HEAT EXCHANGER

1. Open a hot water tap in the house.
2. Fill the hot water heat exchanger through the cold water connection (XL3).
3. When the water coming out of the hot water tap is no longer mixed with air, the hot water heat exchanger is full and the hot water tap can be closed.

FILLING THE CLIMATE SYSTEM

The climate system and SVM S332 are filled by an external filling hose (incl. filling valve) being connected in the product's draining valve (QM1).

1. Open all vent valves (QM23.1–QM23.5).
2. Connect a filling hose to the draining valve for heating medium (QM1).
3. Open the draining valve (QM1) and the external filling valve. SVM S332 and the climate system fill with water.
4. When the water exiting the vent valves (QM23) is no longer mixed with air, close the valves.
5. After a while the pressure rises on the externally mounted pressure gauge (BP5). When the pressure reaches approx. 2.5 bar (025 MPa) the externally mounted safety valve (FL2) starts to release water. Then close the draining valve (QM1).
6. Reduce the climate system's pressure to the normal working range (approx. 1 bar) by opening the vent valves (QM23.1–QM23.5) or the safety valve (FL2).

VENTING THE CLIMATE SYSTEM



TIP!

Use the enclosed venting hose for simpler and easier venting.



NOTE!

Insufficient venting can damage internal components in SVM S332.

1. Turn off SVM S332 using the on/off button. Wait for about 30 seconds.
2. Open all the vent valves (QM23.1–QM23.5-).
3. Fill SVM S332 via the drain connection (QM1) to a pressure of 1.0 bar.
4. Open and close the vent valves (QM23.1–QM23.5) until the pressure drops to 0 bar.
5. Repeat steps 1–4 until no more air emerges from the vent valves.
6. Close the vent valves and fill the product to a pressure of 1.5 bar.
7. Start SVM S332.

8. Follow the instructions in the start guide to vent.
9. The venting procedure can also be activated in menu 4.30.1.

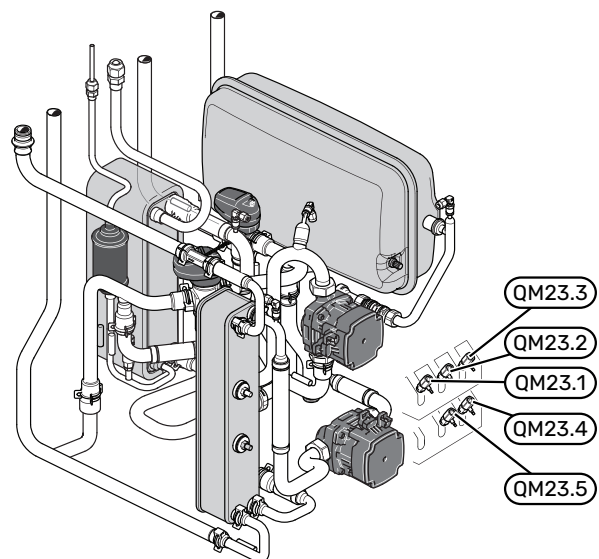
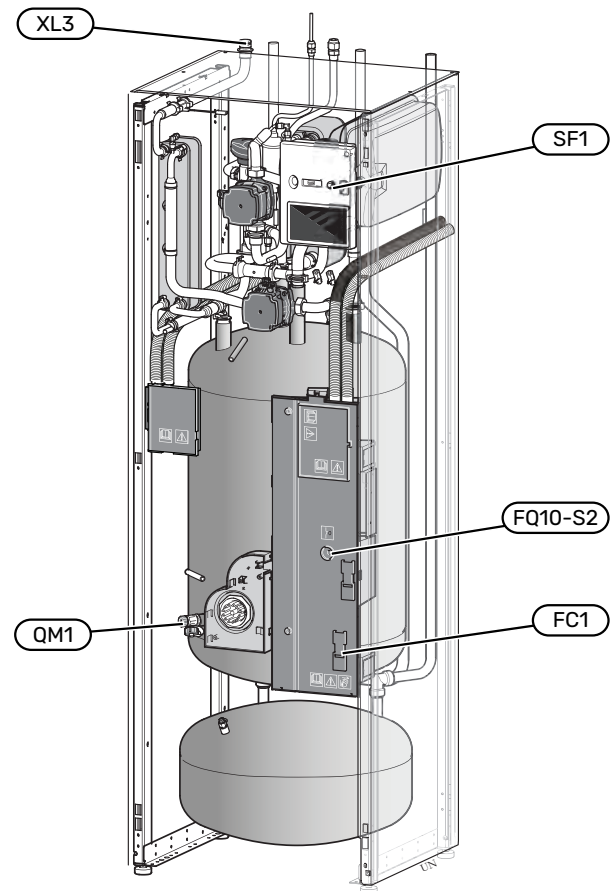

Commissioning

START GUIDE

CAUTION!
There must be water in the climate system before SVM S332 is started.

CAUTION!
Do not start SVM S332 if there is a risk that the water in the system has frozen.

1. Power-up the outdoor unit.
2. Start SVM S332 by pressing the on/off button (SF1).
3. Follow the instructions in the display's start guide. If the start guide does not start when you start the SVM S332, you can start it manually in menu 7.7.

TIP!
See the section "Control – Introduction" for a more detailed introduction to the installation's control system (operation, menus, etc.).

Commissioning

The first time the installation is started a start guide is started. The start guide instructions state what needs to be carried out at the first start together with a run through of the installation's basic settings.

The start guide ensures that the start-up is carried out correctly and, for this reason, cannot be skipped.

NOTE!
As long as the start guide is active, no function in the installation will start automatically.

Operation in the start guide

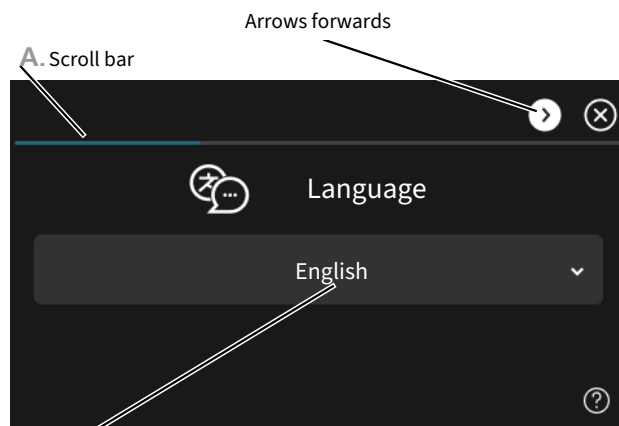

B. Option / setting

A. Scroll bar

Here you can see how far you have come in the start guide.

Drag to the right or left with your finger to browse between the pages.

You can also press the arrows in the top corners to browse.

B. Option / setting

Make settings for the system here.

COMMISSIONING WITHOUT OUTDOOR UNIT

The indoor module can be used without an outdoor unit, i.e. solely as an electric boiler, to produce heat⁵ and hot water, for example before the outdoor unit is installed.

1. Go to menu 4.1 - "Operating mode" and select "Add. heat only".
2. Go to menu 7.3.2 - "Installed heat pump" and deactivate the heat pump..



NOTE!

When commissioning without NIBE outdoor unit the "communication error" alarm may appear in the display.

The alarm is reset if the relevant heat pump is deactivated in menu 7.3.2 - "Installed heat pump"



CAUTION!

Select operating mode "Auto" or "Manual" when the indoor unit is once again to be used with the outdoor unit.

PUMP SPEED

The heating medium pump (GP1) in SVM S332 is frequency controlled and adjusts automatically using control and based on heating demand.

Capacity, heating medium pump (GP1)

Available pressure (kPa)

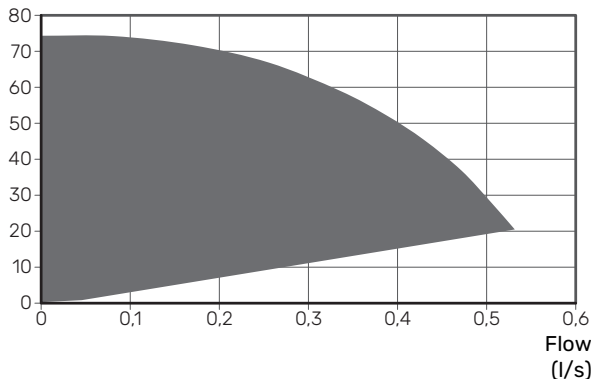

Setting the cooling/heating curve

In the menu "Curve, heating" and "Curve, cooling", you can see the heating and cooling curves for your house. The purpose of the curves is to provide an even indoor temperature, regardless of the outdoor temperature, and thereby energy-efficient operation. Based on these curves, SVM S332 determines the temperature of the water to the climate system (the supply temperature) and thus the indoor temperature.

CURVE COEFFICIENT

The slopes of the heating /cooling curves indicate how many degrees the supply temperature is to be increased/reduced when the outdoor temperature drops/increases. A steeper slope means a higher supply temperature for heating or a lower supply temperature for cooling at a certain outdoor temperature.

The lower the heating curve, the more energy efficient the operation, although an excessively low curve entails reduced comfort.

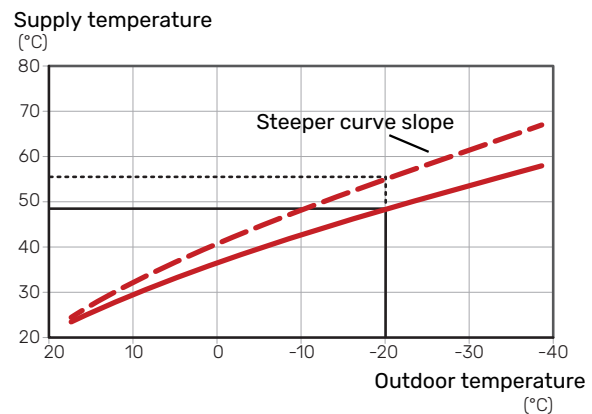

The optimum curve slope depends on the climate conditions and the lowest dimensioned outdoor temperature (DOT) in your location, whether the house has radiators, fan coils or underfloor heating and how well insulated the house is.

For houses with radiators or fan coils, a higher heating curve (e.g. curve 9) is suitable, for houses with under floor heating, a lower curve (e.g. curve 5) is suitable.

The heating/cooling curves are set when the heating/cooling system is installed, but may need adjusting later. Thereafter, the curves should not need further adjustment.

CURVE OFFSET

An offset of the heating curve means that the supply temperature changes by the same amount for all outdoor temperatures, e.g. a curve offset of +2 steps increases the supply temperature by 5 °C at all outdoor temperatures. A corresponding change to the cooling curve results in a lowering of the supply temperature.

⁵ Only SVM S332 3x400 V with shunt valve QN11.

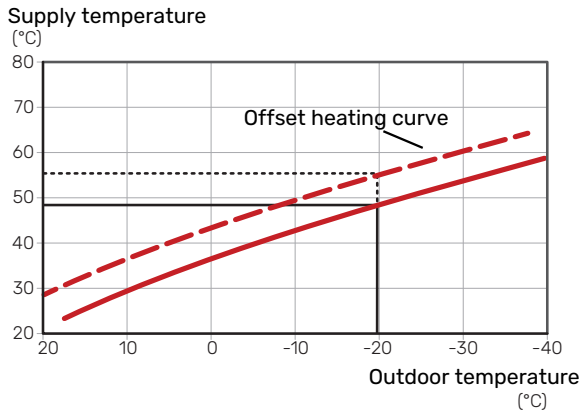

SUPPLY TEMPERATURE - MAXIMUM AND MINIMUM VALUES

Because the supply temperature cannot be calculated higher than the set maximum value or lower than the set minimum value, the curves flatten out at these temperatures.

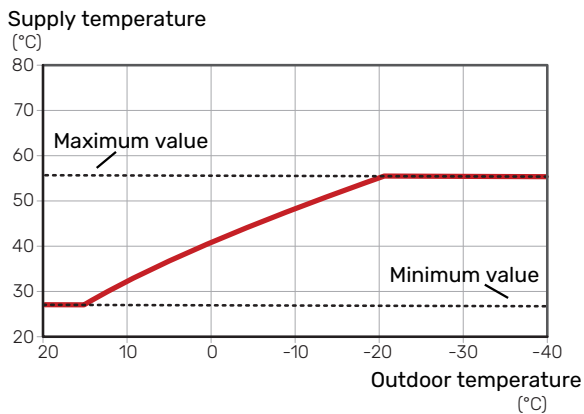

NOTE!

With underfloor heating systems, the maximum supply temperature is normally set between 35 and 45 °C.

NOTE!

With underfloor cooling, "Min. supply temp. cooling" must be restricted to prevent condensation.

ADJUSTMENT OF CURVE

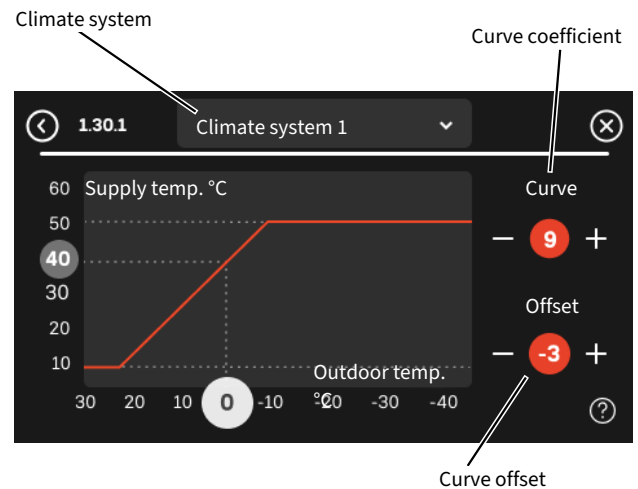

1. Select the climate system (if more than one) for which the curve is to be changed.
2. Select curve slope and curve offset.
3. Select max and min supply temperature.



NOTE!

Curve 0 means that "Own curve" is used.

Settings for "Own curve" are made in menu 1.30.7.

TO READ OFF A HEATING CURVE

1. Drag in the circle on the axis with outdoor temperature.
2. Read off the value for supply temperature in the circle on the other axis.

myUplink

With myUplink you can control the installation – where and when you want. In the event of any malfunction, you receive an alarm directly to your e-mail or a push notification to the myUplink app, which allows you to take prompt action.

It is possible to update the software for SVM S332 via myUplink.

The possibility to view the history and to make changes depends on the myUplink subscription. You can always view and subscribe on the myUplink website.

Visit myuplink.com for more information.

Specification

You need the following in order for myUplink to be able to communicate with your SVM S332:

- wireless network or network cable
- Internet connection
- account on myuplink.com

We recommend our mobile apps for myUplink.

Connection

To connect your system to myUplink:

1. Select connection type (wifi/Ethernet) in menu 5.2.1 or 5.2.2.
2. In menu 5.1 you select "Request new connection string".
3. When a connection string has been produced, it is shown in this menu and is valid for 60 minutes.
4. If you do not already have an account, register in the mobile app or on myuplink.com.
5. Use the connection string to connect your installation to your user account on myUplink.

Range of services

myUplink gives you access to various levels of service. The basic level is included and, in addition to that, you can opt for additional subscriptions for a fee. Visit <https://myuplink.com/store> for more information.

myUplink PRO

myUplink PRO is a complete tool for offering service agreements to the end customer and for always having the latest information about the installation, as well as the option to adjust settings remotely.

With myUplink PRO, you can provide your connected customers with rapid status and remote diagnostics.

Visit pro.myuplink.com for information about what else you can do using the mobile app and online.

Control - Introduction

Display unit

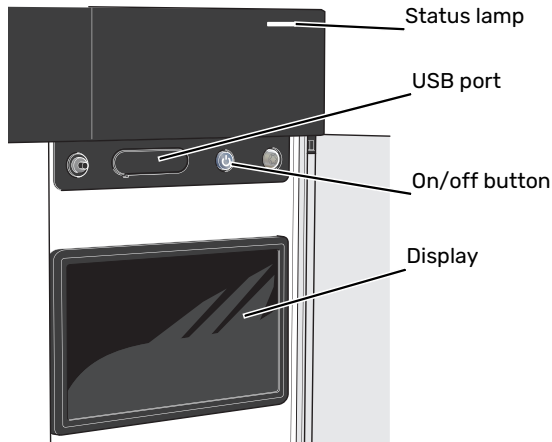

THE STATUS LAMP

The status lamp indicates current operating status. It:

- lights up white during normal operation.
- lights yellow in emergency mode.
- lights red in the event of a deployed alarm.
- flashes white during active notice.
- is blue when SVM S332 is switched off.

If the status lamp is red, you receive information and suggestions for suitable actions on the display.



TIP!

You also receive this information via myUplink.

THE USB PORT

Above the display, there is a USB port that can be used e.g. for updating the software. Log in to myuplink.com and click the "General" tab and then "Software" to download the latest software version for your installation.



TIP!

If you connect the product to myUplink, you can update the software without using the USB port. See section "myUplink".

THE ON/OFF BUTTON

The on/off button (SF1) has three functions:

- start
- switch off
- activate emergency mode

To start: press the on/off button once.

To switch off, restart or activate emergency mode: press and hold the on/off button for 2 seconds. This brings up a menu with various options.

For hard switch off: press and hold the on/off button for 10 seconds.

To activate emergency mode when SVM S332 is switched off: press and hold the on/off button (SF1) for 5 seconds. (Deactivate the emergency mode by pressing once).

THE DISPLAY

Instructions, settings and operational information are shown on the display.

Navigation

SVM S332 has a touchscreen where you simply navigate by pressing and dragging with your finger.

SELECT

Most options and functions are activated by lightly pressing on the display with your finger.



BROWSE

The symbols at the bottom edge show if there are more pages.

Drag to the right or left with your finger to browse between the pages.

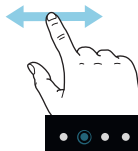

SCROLL

If the menu has several sub-menus, you can see more information by dragging up or down with your finger.



CHANGE A SETTING

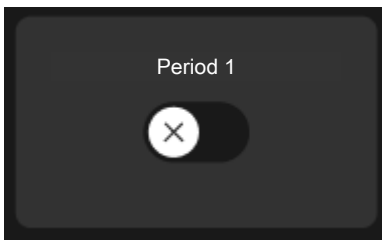

Press the setting you want to change.

If it is an on/off setting, it changes as soon as you press it.

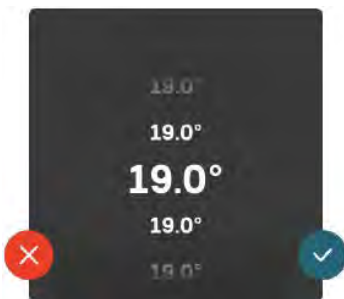

If there are several possible values, a spinning-wheel appears that you drag up or down to find the desired value.



Press  to save your change, or  if you don't want to make a change.

FACTORY SETTING

Factory set values are marked with *.

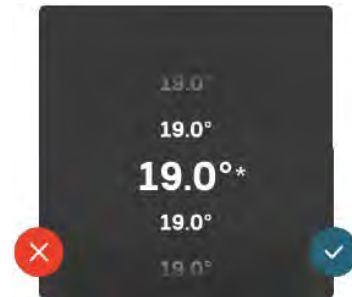

HELP MENU

 In many menus there is a symbol that indicates that extra help is available.

Press the symbol to open the help text.

You may need to drag with your finger to see all text.

Menu types

HOME SCREENS

Smartguide

Smartguide helps you both to view information about the current status and to make the most common settings easily. The information that you see depends on the product you have and the accessories that are connected to the product.

Select an option and press it to proceed. The instructions on the screen help you to choose correctly or give you information about what is happening.

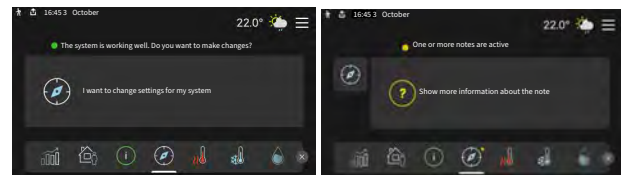

Function pages

On the function pages, you can both view information about the current status and easily make the most common settings. The function pages that you see depend on the product you have and the accessories that are connected to the product.

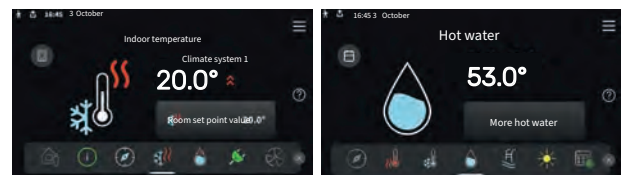

Drag to the right or left with your finger to browse between the function pages.

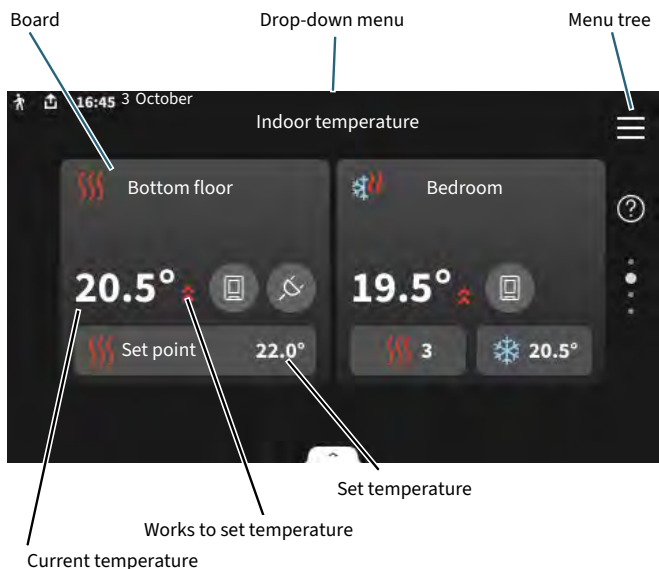

Press the card to adjust the desired value. On certain function pages, drag your finger up or down to obtain more cards.

Product overview

It can be a good idea to have the product overview open during any service cases. You can find it among the function pages.

Here, you can find information about the product name, the product's serial number, the version of the software, and the contact details of the company that provides service. When there is new software to download, you can do it here (provided that SVM S332 is connected to myUplink).



TIP!

You enter the service details in menu 4.11.1.

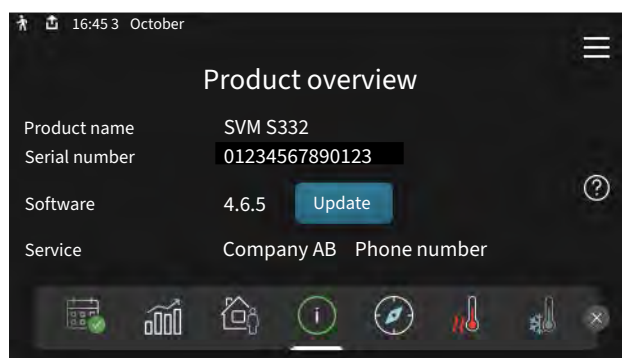

Drop-down menu

From the home screens, you reach a new window containing further information by dragging down a drop-down menu.



The drop-down menu shows the current status for SVM S332, what is in operation and what SVM S332 is doing at the moment. The functions that are in operation are highlighted with a frame.

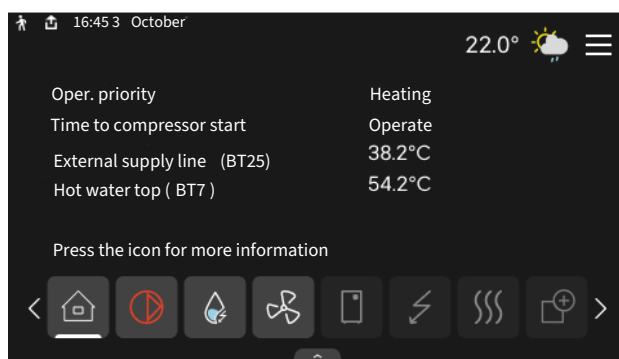

Press the icons on the menu's lower edge for more information about each function. Use the scroll bar to view all information for the selected function.

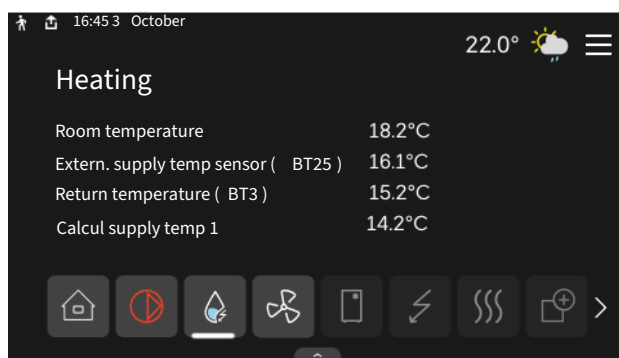

MENU TREE AND INFORMATION

In the menu tree, you can find all menus and can make more advanced settings.

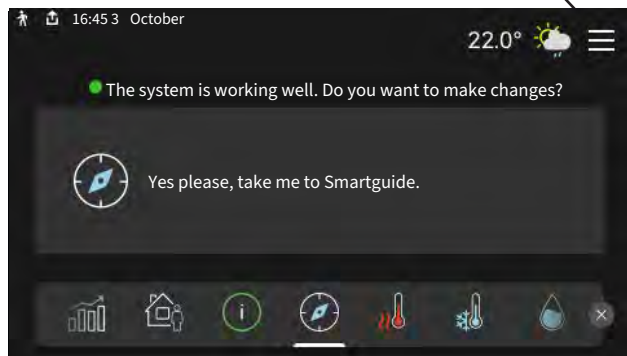

You can always press "X" to return to the home screens.

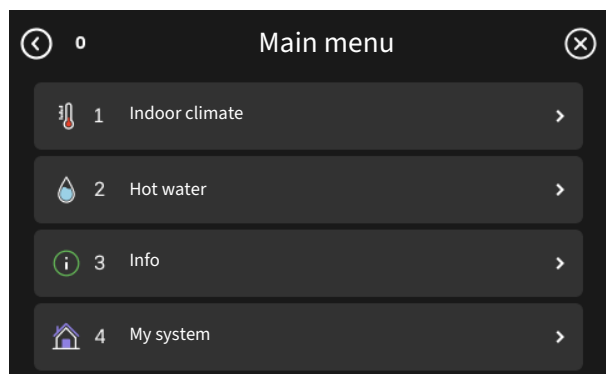

Climate systems and zones

Climate systems can be divided into multiple zones. A zone can be a specific room, and it is also possible to divide a large room into several zones, with the help of radiator thermostats.

Each zone can contain one or more accessories, e.g. room sensors or thermostats, both wired and wireless.

A zone can be set with or without the influence of the climate system's supply temperature.

OUTLINE DIAGRAM WITH TWO CLIMATE SYSTEMS AND FOUR ZONES

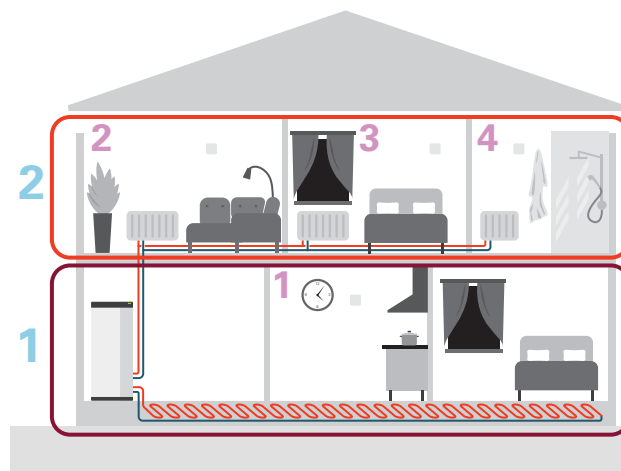

This example shows a property with two climate systems (1 and 2, two separate floors) divided into four zones (1-4, four different rooms). The temperature can be controlled individually in each zone (accessory required).

Control – Menus

Menu 1 – Indoor climate

OVERVIEW

| | |
|--------------------------------|--|
| 1.1 - Temperature | 1.1.1 - Indoor temperature |
| | 1.1.2 - Cooling |
| | 1.1.3 - Humidity ¹ |
| 1.2 - Ventilation ¹ | 1.2.1 - Fan speed ¹ |
| | 1.2.2 - Night cooling ¹ |
| | 1.2.4 - Demand controlled ventilation ¹ |
| | 1.2.5 - Fan return time ¹ |
| | 1.2.6 - Filter cleaning interval ¹ |
| | 1.2.7 - Ventilation recovery ¹ |
| 1.3 - Room sensor settings | 1.3.3 - Room sensor settings |
| | 1.3.4 - Zones |
| 1.5 - Climate system name | |
| 1.30 - Advanced | 1.30.1 - Curve, heating |
| | 1.30.2 - Curve, cooling |
| | 1.30.3 - External adjustment |
| | 1.30.4 - Lowest supply heating |
| | 1.30.5 - Lowest supply cooling |
| | 1.30.6 - Highest supply heat |
| | 1.30.7 - Own curve |
| | 1.30.8 - Point offset |

¹ Consult the accessory's Installer Manual.

MENU 1.1 - TEMPERATURE

Here, you make temperature settings for your installation's climate system.

If there is more than one zone and/or climate system, the settings are made for each zone/system.

MENU 1.1.1 - INDOOR TEMPERATURE

Set the temperature (with room sensor installed and activated):

Setting range: 5 – 35°C

Cooling, 2-pipe, is activated in menu 7.3.2.1. Accessories are needed to run cooling, 4-pipe.

The value in the display appears as a temperature in °C, if the zone is controlled by a room sensor.

NOTE!

A slow climate system, such as underfloor heating, may be unsuitable for controlling with room sensors.

Setting the temperature (without room sensors activated):

Setting range: -10 – 10

The display shows the set value for heating/cooling (curve offset). To increase or reduce the indoor temperature, increase or reduce the value in the display.

The number of steps the value has to be changed in order to achieve a one degree change to the indoor temperature depends on the climate system. One step is usually enough, but in some cases several steps may be required.

If multiple zones in a climate system do not have activated room sensors, these will have the same curve offset.

Set the desired value. The new value is shown on the right-hand side of the symbol on home screen heating/home screen indoor temperature.



NOTE!

An increase in the room temperature can be slowed by the thermostats for the radiators or under floor heating. Therefore, open the thermostats fully, except in those rooms where a cooler temperature is required, e.g. bedrooms.



TIP!

If the room temperature is constantly too low/high, you increase/decrease the value on the indoor temperature home screen.

If the room temperature changes when the outdoor temperature changes, you increase/decrease the curve slope by one step in menu 1.30.1.

Wait 24 hours before making a new setting, so that the room temperature has time to stabilise.

MENU 1.3 - ROOM SENSOR SETTINGS

Here, you make your settings for room sensors and zones. The room sensors are grouped by zone.

MENU 1.3.3 - ROOM SENSOR SETTINGS

Here, you select the zone to which a sensor will belong. It is possible to connect multiple room sensors to each zone. Each room sensor can be given a unique name.

The control of heating and cooling is activated by ticking the relevant option. Which options are shown depends on which type of sensor is installed. If control is not activated, the sensor will be the displaying sensor.

Smart Room Comfort is activated, if a controlling room sensor is connected. A zone is regulated by the weather forecast and the indoor temperature.



NOTE!

A slow heating system such as underfloor heating may be inappropriate for controlling with room sensors.

If there is more than one zone and/or climate system, the settings are made for each zone/system.

MENU 1.3.4 - ZONES

Here, you add and name zones. You also select the climate system to which a zone is to belong.

MENU 1.5 - CLIMATE SYSTEM NAME

You can give the installation's climate system a name here.

MENU 1.30 - ADVANCED

Menu "Advanced" is intended for the advanced user. This menu has several sub-menus.

"Curve, heating" Setting the heating curve slope.

"Curve, cooling" Setting the cooling curve slope.

"External adjustment" Setting the heating curve offset when the external contact is connected.

"Lowest supply heating" Setting minimum permitted supply temperature during heating operation.

"Lowest supply cooling" Setting minimum permitted supply temperature during cooling operation.

"Highest supply heat" Setting maximum permitted supply temperature for the climate system.

"Own curve" You can create your own heating curve here, if there are special requirements, by setting the desired supply temperatures for different outdoor temperatures.

"Point offset" Select a change in the heating curve at a certain outdoor temperature here. One step is usually enough to change the room temperature by one degree, but in some cases several steps may be required.

MENU 1.30.1 - CURVE, HEATING

Curve, heating

Setting range: 0 – 15

The heating curve can be found in this menu. The task of the heating curve is to provide a uniform indoor temperature, regardless of the outdoor temperature, and thereby energy efficient operation. It is from the heating curve that SVM S332 determines the temperature of the water to the climate system, the supply temperature, and therefore the indoor temperature.

For houses with radiators or fan coils, a higher heating curve (e.g. curve 9) is suitable, for houses with under floor heating, a lower curve (e.g. curve 5) is suitable.

When you have selected the heating curve, you can read off how the supply temperature will change at different outdoor temperatures.



TIP!

It is also possible to create your own curve. This is done in menu 1.30.7.



NOTE!

With underfloor heating systems, the maximum supply temperature is normally set between 35 and 45 °C.



TIP!

If the room temperature is constantly too low/high, you increase/decrease the curve offset by one step.

If the room temperature changes when the outdoor temperature changes, you increase/decrease the curve slope by one step.

Wait 24 hours before making a new setting, so that the room temperature has time to stabilise.

MENU 1.30.2 - CURVE, COOLING

Curve, cooling

Setting range: 0 – 9

The cooling curve can be found in this menu. The task of the cooling curve is, together with the heating curve, to provide a uniform indoor temperature, regardless of the outdoor temperature, and thereby energy-efficient operation. Based on these curves, SVM S332 determines the temperature of the water to the climate system, the supply temperature, and thus the indoor temperature.

For houses with fan coils, a higher curve (e.g. curve 9) is appropriate, for houses with under floor cooling, a lower curve (e.g. curve 5) is appropriate.

When you have selected the cooling curve, you can read off how the supply temperature will change at different outdoor temperatures.



NOTE!

With underfloor cooling, "Min. supply temp. cooling" must be restricted to prevent condensation.

Cooling in 2-pipe system

SVM S332 contains a built-in function for operating cooling in a 2-pipe system down to 7 °C.

For operating mode "cooling" to be permitted, the average temperature must be above the set value for "start cooling" in menu 7.1.10.2 "Auto mode setting". There is the option to activate cooling by selecting "manual" operating mode in menu 4.1 "Operating mode".

The cooling settings for the climate system are adjusted in the indoor climate menu, menu 1.

MENU 1.30.3 - EXTERNAL ADJUSTMENT

External adjustment

Setting range: -10 – 10

Setting range (if room sensor is installed): 5 – 30 °C

Connecting an external switch, for example a room thermostat or a timer, allows you to raise or lower the room temperature temporarily or periodically. When the switch is on, the heating curve offset is changed by the number of steps selected in the menu. If a room sensor is installed and activated, the desired room temperature (°C) is set.

If there is more than one zone, the setting can be made separately for each zone.

MENU 1.30.4 - LOWEST SUPPLY HEATING

Heating

Setting range: 5 – 80 °C

Set the minimum temperature on the supply temperature to the climate system. This means that SVM S332 never calculates a temperature lower than that set here.

If there is more than one climate system the setting can be made separately for each system.

MENU 1.30.5 - LOWEST SUPPLY COOLING

Cooling

Setting range: 7 – 30 °C

Alarm, room sensor during cooling operation

Alternative: on/off

Set the minimum temperature on the supply temperature to the climate system. This means that SVM S332 never calculates a temperature lower than that set here.

If there is more than one climate system the setting can be made separately for each system.

Here, you can receive alarms during cooling operation, for example if a room sensor malfunctions.



CAUTION!

The cooling supply line must be set with regard to which climate system is connected. For example, under floor cooling with too low supply temperature can cause condensation to precipitate, which in the worst instance could lead to moisture damage.

MENU 1.30.6 - HIGHEST SUPPLY HEAT

Climate system

Setting range: 5 – 80 °C

Here, you set the highest supply temperature for the climate system. This means that SVM S332 never calculates a temperature higher than the one set here.

If there is more than one climate system the setting can be made separately for each system. Climate systems 2 – 8 cannot be set to a higher max supply temperature than climate system 1.

**NOTE!**

With underfloor heating systems, "Maximum supply temperature for heating" should normally be set between 35 and 45°C.

**NOTE!**

Wait 24 hours before making a new setting, so that the room temperature has time to stabilise.

MENU 1.30.7 - OWN CURVE**Own curve, heat****Supply temp**

Setting range: 5 – 80 °C

**NOTE!**

Curve 0 must be selected for own curve to apply.

You can create your own heating curve here, if there are special requirements, by setting the desired supply temperatures for different outdoor temperatures.

Own curve, cooling**Supply temp**

Setting range: 7 – 40 °C

**NOTE!**

Curve 0 must be selected for own curve to apply.

You can create your own cooling curve here, if there are special requirements, by setting the desired supply temperatures for different outdoor temperatures.

MENU 1.30.8 - POINT OFFSET**Outdoor temp. point**

Setting range: -40 – 30 °C

Change in curve

Setting range: -10 – 10 °C

Select a change in the heating curve at a certain outdoor temperature here. One step is usually enough to change the room temperature by one degree, but in some cases several steps may be required.

The heating curve is affected at $\pm 5^\circ\text{C}$ from set outdoor temp. point.

It is important that the correct heating curve is selected so that the room temperature is experienced as even.

**TIP!**

If it feels cold in the house at e.g. -2°C , "outdoor temp. point" is set to "-2" and "change in curve" is increased until the desired room temperature is maintained.

Menu 2 – Hot water

OVERVIEW

2.1 - More hot water

2.2 - Hot water demand

2.3 - External influence

2.5 - Hot water circulation

MENU 2.1 - MORE HOT WATER

More hot water

Alternatives: 3, 6, 12, 24 and 48 hours, and modes "Off" and "One-time incr."

Quick start with imm. heater

Alternative: on/off

"More hot water" When there is a temporary increase in hot water demand, this menu can be used to select an increase in the hot water temperature for a selectable time.

If the hot water temperature is already sufficiently high, "One-time incr." cannot be activated.

The function is activated directly when a time period is selected. The remaining time for the selected setting is shown to the right.

When the time has run out, SVM S332 returns to the set demand mode.

Select "Off" to switch off "More hot water".

"Quick start with imm. heater" gives faster heating, but can lead to increased energy consumption.

MENU 2.2 - HOT WATER DEMAND

Options: Small, Medium, Large, Smart control

The difference between the selectable modes is the temperature of the hot tap water. Higher temperature means that the hot water lasts longer.

Small: This mode produces less hot water at a lower temperature than the other alternatives. This mode can be used in smaller households with a small hot water demand.

Medium: Normal mode produces a larger amount of hot water and is suitable for most households.

Large: This mode produces the most hot water at a higher temperature than the other alternatives. In this mode, the immersion heater may be used to partially heat the hot water. In this mode, hot water production is prioritised ahead of heating.

Smart control: With Smart control activated, SVM S332 continuously learns the previous hot water consumption and, in this way, adjusts the temperature in the water heater for the minimum energy consumption and maximum comfort.

MENU 2.3 - EXTERNAL INFLUENCE

Information for the accessories/functions that can affect the hot water operation is shown here.

MENU 2.5 - HOT WATER CIRCULATION

Operating time

Setting range: 1 – 60 min

Downtime

Setting range: 0 – 60 min

Period

Active days

Alternatives: Monday – Sunday

Start time

Setting range: 00:00 – 23:59

Stop time

Setting range: 00:00 – 23:59

Set hot water circulation for up to five periods per day here. During the set periods, the hot water circulation pump will run according to the settings above.

"Operating time" determines how long the hot water circulation pump will run per operating instance.

"Downtime" determines how long the hot water circulation pump will be stationary between operating instances.

"Period" Here, you set the time period during which the hot water circulation pump will run, by selecting "Active days", "Start time" and "Stop time".



CAUTION!

Hot water circulation is activated in menu 7.4 "Selectable in/outputs" or via accessory.

Menu 3 - Info

OVERVIEW

| | |
|-----------------------------------|--------------------|
| 3.1 - Operating info | |
| 3.2 - Temperature log | |
| 3.3 - Energy and power log | 3.3.1 - Energy log |
| | 3.3.2 - Power log |
| 3.4 - Alarm log | |
| 3.5 - Product info, summary | |
| 3.6 - Licences | |
| 3.7 - Version history | |
| 3.8 - Data protection information | |

MENU 3.1 - OPERATING INFO

Information about the installation's current operating status (e.g. current temperatures) can be obtained here. No changes can be made.

You can also read off operating information from all your connected wireless units.

A QR code appears on one side. This QR code indicates serial number, product name and limited operating data.

MENU 3.2 - TEMPERATURE LOG

Here you can see the average temperature indoors week by week over the past year.

The average outdoor temperature is only shown if a room temperature sensor/room unit is installed.

In installations with ventilation accessories and no room sensors (BT50), the exhaust air temperature is displayed instead.

MENU 3.3 - ENERGY AND POWER LOG

Here, you can select which parts of the installation will be included in the log.

MENU 3.3.1 - ENERGY LOG

Number of years

Setting range: 1 - 10 years

Months

Setting range: 1 - 24 months

Include heating

Alternative: on/off

Include hot water

Alternative: on/off

Show outdoor temperature

Alternative: on/off

Show indoor temperature

Alternative: on/off

Here, you can see a diagram showing how much energy SVM S332 supplies and consumes. You can select which parts of the installation will be included in the log. It is also possible to activate display of indoor and/or outdoor temperature.

MENU 3.3.2 - POWER LOG

Here, you can see how much power the installation has consumed at a given time of day. You can choose to view either hourly or every 15 mins.

MENU 3.4 - ALARM LOG

To facilitate troubleshooting, the installation's operating status at the time of an alarm is stored here. You can see information for the 10 most recent alarms.

To view operating status in the event of an alarm, select the relevant alarm from the list.

MENU 3.5 - PRODUCT INFO, SUMMARY

Here, you can see general information about your system, such as software versions.

MENU 3.6 - LICENCES

You can view licences for open source code here.

MENU 3.7 - VERSION HISTORY

Here you can see what is new and/or has been changed in different software versions.

MENU 3.8 - DATA PROTECTION INFORMATION

Here, you can see what data NIBE collects for troubleshooting and optimising the product.

Menu 4 - My system

OVERVIEW

| | |
|-----------------------------|---|
| 4.1 - Operating mode | |
| 4.2 - Plus functions | 4.2.2 - Solar electricity ¹ |
| | 4.2.3 - SG Ready |
| | 4.2.5 - Smart Price Adaption™ |
| | 4.2.5.1 - Electricity price table |
| | 4.2.5.2 - Transfer fee |
| 4.3 - Profiles ¹ | |
| 4.4 - Weather control | |
| 4.5 - Away mode | |
| 4.6 - Smart Energy Source™ | |
| 4.7 - Energy price | |
| | 4.7.1 - Variable electricity price |
| | 4.7.3 - Shunt-controlled additional heat ¹ |
| | 4.7.4 - Step-controlled additional heat ¹ |
| | 4.7.6 - External additional heat ¹ |
| 4.8 - Time and date | |
| 4.9 - Language | |
| 4.10 - Country | |
| 4.11 - Tools | |
| | 4.11.1 - Installer details |
| | 4.11.2 - Sound when pressing button |
| | 4.11.4 - Home screen |
| 4.30 - Advanced | |
| | 4.30.4 - Fact. settings user |

¹ Consult the accessory's Installer Manual.

MENU 4.1 - OPERATING MODE

Operating mode

Alternative: Auto, Manual, Add. heat only

Manual

Alternative: Compressor, Add. heat, Heating, Cooling

Add. heat only

Alternative: Heating

The operating mode for SVM S332 is normally set to "Auto". It is also possible to select operating mode "Add. heat only". Select "Manual" to choose that functions will be activated.

If "Manual" or "Add. heat only" is selected, selectable options are shown further down. Tick the functions you want to activate.

Operating mode "Auto"

In this operating mode, SVM S332 automatically selects which functions are permitted.

Operating mode "Manual"

In this operating mode you can select what functions are permitted.

"Compressor" is the unit that produces hot water, heating and cooling for the property. You cannot deselect "compressor" in manual mode.

"Add. heat" is the unit that helps the compressor to heat the property and/or the hot water when it cannot manage the entire demand alone.

"Heating" ensures you obtain heating in the property. You can deselect the function, when you do not wish to have the heating on.

"Cooling" ensures that you obtain cooling in the property in hot weather. You can deselect this function, when you do not wish to have cooling in operation.



NOTE!

If you deselect "Add. heat", it may result in you not obtaining sufficient hot water and/or heating in the property.

Operating mode "Add. heat only"

In this operating mode the compressor is not active, only additional heat is used.



NOTE!

If you choose mode "Add. heat only" the compressor is deselected and there is a higher operating cost.

MENU 4.2 - PLUS FUNCTIONS

Settings for any additional functions installed in SVM S332 can be made in the sub menus.

MENU 4.2.3 - SG READY

Here, you set the part of your climate system (e.g. room temperature) that will be affected on activation of "SG Ready". The function can only be used in mains networks that support the "SG Ready" standard.

Affect room temp heating

With low price mode on "SG Ready", the parallel offset for the indoor temperature is increased by "+1". If a room sensor is installed and activated, the desired room temperature is increased instead by 1 °C.

With overcapacity mode on "SG Ready", the parallel offset for the indoor temperature is increased by "+2". If a room sensor is installed and activated, the desired room temperature is increased by 2 °C instead.

Affect hot water

With low price mode on "SG Ready", the stop temperature for the hot water is set as high as possible with compressor operation only (immersion heater not permitted).

In the case of overcapacity mode on "SG Ready", the hot water is set to large demand mode (immersion heater permitted).

Affect room temp cooling

With low price mode of "SG Ready" and cooling operation the indoor temperature is not affected.

With overcapacity mode on "SG Ready" and cooling operation, the parallel offset for the indoor temperature is decreased by "-1". If a room sensor is installed and activated, the desired room temperature is decreased by 1 °C instead.



CAUTION!

The function must be connected to two AUX inputs and be activated in menu 7.4 "Selectable in/outputs".

MENU 4.2.5 - SMART PRICE ADAPTION™

Activated

Alternative: on/off

Price source

Options: "Spot price", "Manual"

Affect heating

Options: "Off", "Comfort", "Saving", "Saving PLUS"

Affect room temp cooling

Options: "Off", "Comfort", "Saving", "Saving PLUS"

Affect hot water

Alternative: on/off

With smart control activated in menu 2.2

Options: "Off", "Comfort", "Saving", "Saving PLUS"

This function can only be used if you have an active account on myUplink and your electricity supplier supports electricity contracts that are based on the current spot price.

Smart price adaption™ adjusts some of the installation's consumption throughout the day to those periods that have the cheapest electricity prices, which can provide savings if you are on a spot price electricity contract. The function is based on downloading the electricity prices for the coming 24 hours via myUplink.

Price source Here, you can choose whether to use spot prices or to enter prices manually.

Degree of effect: The greater the saving you select, the greater the effect the electricity price has.

Certain wireless units can also be affected by Smart Price Adaption™.



CAUTION!

Increased savings can lead to a negative impact on the comfort.

MENU 4.2.5.1 - ELECTRICITY PRICE TABLE

If you have selected "Price source" in option "Price source" in menu 4.2.5 - Smart Price Adaption™, you can enter the electricity price for individual time periods.

MENU 4.2.5.2 - TRANSFER FEE

If you have selected "Spot price" in menu 4.2.5 - Smart Price Adaption™ you can define transfer fees and assign them to specific time periods. The changes take effect the following day.

MENU 4.4 - WEATHER CONTROL

Activate weath. contr.

Alternative: on/off

Factor

Setting range: 0 – 10

You can select whether you want SVM S332 to adjust the indoor temperature based on the weather forecast.

You can set factor for outdoor temperature. The higher the value, the greater the effect from the weather forecast.



NOTE!

This menu is only visible if the installation is connected to myUplink and if a climate system is not using room control.

MENU 4.5 - AWAY MODE

In this menu, you activate/deactivate "Away mode".

When away mode is activated, the following functions are affected:

- the setting for heating is lowered slightly
- the setting for cooling is raised slightly
- the hot water temperature is lowered if demand mode "large" or "medium" is selected
- The AUX function "Away mode" is activated.

If you want, you can select for the following functions to be affected:

- ventilation (accessory is required)
- hot water circulation (accessory or use of AUX is required)

MENU 4.6 - SMART ENERGY SOURCE™



CAUTION!

Smart Energy Source™ requires external additional heat.

Smart Energy Source™

Alternative: on/off

Control method

Setting options: Price per kWh / CO2

If Smart Energy Source™ is activated, SVM S332 prioritises how/to what extent each docked energy source will be used. Here, you can select whether the system will use the energy source that is cheapest at the time or the one that is currently the most carbon dioxide neutral.



NOTE!

Your choices in this menu affect menu 4.7 - "Energy price".

MENU 4.7 - ENERGY PRICE

Here you can use tariff control for your additional heat.

Here you can choose whether the system is to exercise control based on the spot price, tariff control or a set price. The setting is made for each individual energy source. Spot price can only be used if you have an hourly tariff agreement with your electricity supplier.

Set the lower tariff periods. It is possible to set two different date periods per year. Within these periods, it is possible to set up to four different periods on weekdays (Monday to Friday) or four different periods on weekends (Saturdays and Sundays).



NOTE!

This menu can only be seen if Smart Energy Source™ is activated.

MENU 4.7.1 - VARIABLE ELECTRICITY PRICE

Here you can use tariff control for the electric additional heat.

Set the lower tariff periods. It is possible to set two different date periods per year. Within these periods, it is possible to set up to four different periods on weekdays (Monday to Friday) or four different periods on weekends (Saturdays and Sundays).

MENU 4.8 - TIME AND DATE

Set time and date, display mode and time zone here.



TIP!

Time and date are set automatically if connected to myUplink. To obtain the correct time, the time zone must be set.

MENU 4.9 - LANGUAGE

Choose the language that you want the information to be displayed in here.

MENU 4.10 - COUNTRY

Here, you specify the country in which the product has been installed. This allows access to country-specific settings in your product.

Language settings can be made regardless of this selection.



CAUTION!

This option locks after 24 hours, restart of display or program updating. Afterwards, it is not possible to change the country selected in this menu without first replacing components in the product.

MENU 4.11 - TOOLS

Here, you can find tools for use.

MENU 4.11.1 - INSTALLER DETAILS

The installer's name and telephone number are entered in this menu.

Afterwards, the details are visible in the home screen, "Product overview".

MENU 4.11.2 - SOUND WHEN PRESSING BUTTON

Alternative: on/off

Here you choose if you want to hear a sound when you press buttons on the display.

MENU 4.11.4 - HOME SCREEN

Alternative: on/off

Here, you choose which home screens you want to be displayed.

The number of options in this menu varies depending on which products and accessories are installed.

MENU 4.30 - ADVANCED

Menu "Advanced" is intended for advanced users.

MENU 4.30.4 - FACT. SETTINGS USER

All settings that are available to the user (including advanced menus) can be reset to default values here.



NOTE!

After the factory setting, personal settings such as the heating curve must be reset.

Menu 5 - Connection

OVERVIEW

| | |
|------------------------|----------------------------|
| 5.1 - myUplink | |
| 5.2 - Network settings | 5.2.1 - wifi |
| | 5.2.2 - Ethernet |
| 5.4 - Wireless units | |
| 5.10 - Tools | 5.10.1 - Direct connection |

MENU 5.1 - MYUPLINK

Here, you obtain information about the installation's connection status, serial number and how many users and service partners are connected to the installation. A connected user has a user account in myUplink, which has been given permission to control and/or monitor your installation.

You can also manage the installation's connection to myUplink and request a new connection string.

It is possible to switch off all users and service partners who are connected to the installation via myUplink.



CAUTION!

After disconnecting all users none of them can monitor or control your installation via myUplink without requesting a new connection string.

MENU 5.2 - NETWORK SETTINGS

Here, you choose whether your system connects to the Internet via wifi (menu 5.2.1) or via a network cable (Ethernet) (menu 5.2.2).

Here, you can set TCP/IP settings for your installation.

To set the TCP/IP settings with the aid of DHCP, activate "Automatic".

During manual setting, select "IP address" and enter the correct address using the keyboard. Repeat this procedure for "Network mask", "Gateway" and "DNS".



NOTE!

The installation cannot connect to the Internet without the correct TCP/IP settings. If you are unsure about applicable settings, use the "Automatic" mode or contact your network administrator (or equivalent) for further information.



TIP!

All settings made since opening the menu can be reset by selecting "Reset".

MENU 5.4 - WIRELESS UNITS

In this menu you connect wireless devices, and manage settings for connected devices.

Add the wireless unit by pressing "Add unit". For the quickest identification of a wireless unit, it is recommended that you put your master unit in search mode first. Then put the wireless unit in identification mode.

MENU 5.10 - TOOLS

As the installer, you can e.g. connect an installation via an app here, by activating an access point for direct connection to a mobile phone.

MENU 5.10.1 - DIRECT CONNECTION

If you have a user account in myUplink PRO, you can activate direct connection via wifi. This means that the installation will lose communication with the relevant network, and that you instead make settings via your mobile unit, which you connect to the installation.

Menu 6 - Scheduling

OVERVIEW

6.1 - Holiday

6.2 - Scheduling

MENU 6.1 - HOLIDAY

In this menu, you schedule longer changes in heating and hot water temperature.

You can also schedule settings for certain installed accessories.

If a room sensor is installed and activated, the desired room temperature (°C) is set during the time period.

If a room sensor is not activated, the desired offset of the heating curve is set. One step is usually enough to change the room temperature by one degree, but in some cases several steps may be required.



TIP!

Stop the holiday setting about a day before your return so that room temperature and hot water have time to return to their usual levels.



NOTE!

Holiday settings finish on the selected date. If you want to repeat the holiday setting once the end date has passed, go into the menu and change the date.

MENU 6.2 - SCHEDULING

In this menu, you schedule repeated changes of heating and hot water, for example.

You can also schedule settings for certain installed accessories.



NOTE!

A schedule repeats according to the selected setting (e.g. every Monday) until you go into the menu and switch it off.

A mode contains settings that will apply to scheduling. Create a mode with one or more settings by pressing "New mode".

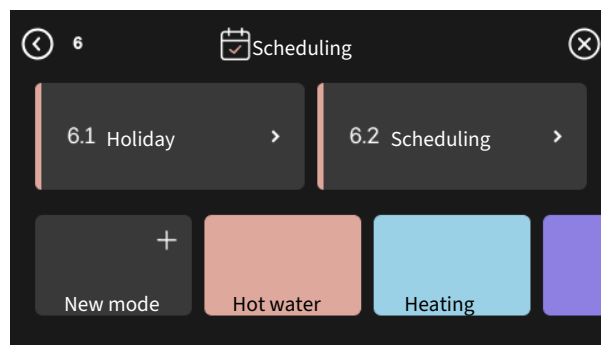

Select the settings that the mode will contain. Drag to the left with your finger to select mode name and colour to make it unique and to distinguish it from other modes.

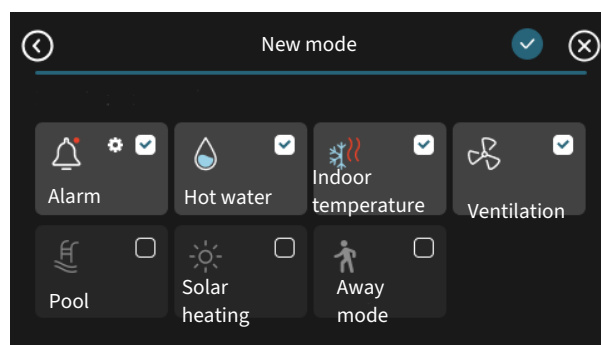

Select an empty row and press it to schedule a mode, and adjust as required. You can enter a tick, if a mode is to be active during the day or overnight.

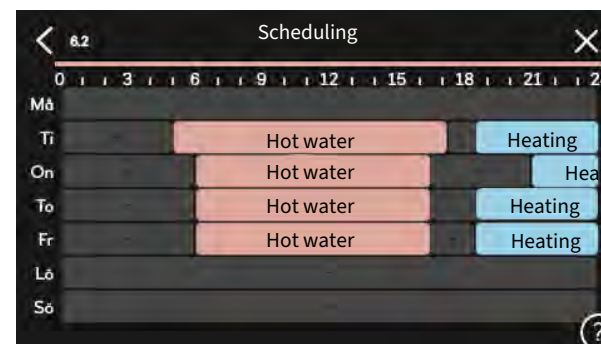

If a room sensor is installed and activated, the desired room temperature (°C) is set during the time period.

If a room sensor is not activated, the desired offset of the heating curve is set. One step is usually enough to change the room temperature by one degree, but in some cases several steps may be required.

Menu 7 - Service

OVERVIEW

| | | |
|---------------------------------------|------------------------------------|--|
| 7.1 - Operating settings | 7.1.1 - Hot water | 7.1.1.1 - Temperature setting |
| | | 7.1.1.3 - Domestic hot water settings |
| | 7.1.2 - Circulation pumps | 7.1.2.1 - Op. mode HM pump GP1 |
| | 7.1.2 - Circulation pumps | 7.1.2.2 - Pp sp. heating medium GP1 |
| | | 7.1.2.5 - Flow setting charge pump |
| | 7.1.4 - Ventilation ¹ | 7.1.4.1 - Fan speed, exhaust air ¹ |
| | | 7.1.4.2 - Fan speed, supply air ¹ |
| | | 7.1.4.3 - Fine-tuning the ventilation ¹ |
| | | 7.1.4.4 - Demand contr. ventilation ¹ |
| | 7.1.5 - Add. heat | 7.1.5.1 - Int elec add heat |
| | 7.1.6 - Heating | 7.1.6.1 - Max diff supply temp |
| | | 7.1.6.2 - Flow settings, climate sys |
| | | 7.1.6.3 - Power at DOT |
| | 7.1.7 - Cooling | 7.1.7.1 - Cooling settings |
| | | 7.1.7.2 - Humidity control ¹ |
| | | 7.1.7.3 - System settings cooling |
| | | 7.1.7.5 - Largest diff. cooling |
| | 7.1.8 - Alarms | 7.1.8.1 - Alarm actions |
| | | 7.1.8.2 - Emergency mode |
| | 7.1.9 - Load monitor | |
| | 7.1.10 - System settings | 7.1.10.1 - Operating prioritisation |
| | | 7.1.10.2 - Auto mode setting |
| | | 7.1.10.3 - Degree minute settings |
| 7.2 - Accessory settings ¹ | 7.2.1 - Add/remove accessories | |
| | 7.2.19 - External energy meter | |
| 7.3 - Multi-installation | 7.3.1 - Configure | |
| | 7.3.2 - Installed heat pump | |
| | 7.3.3 - Name heat pump | 7.3.2.1 - Heat pump settings |
| 7.4 - Selectable in/outputs | 7.4.1 - Enter a name BT37.x | |
| | 7.4.2 - External power limiting | |
| 7.5 - Tools | 7.5.1 - Heat pump, test | 7.5.1.1 - Test mode |
| | 7.5.2 - Underfloor drying function | |
| | 7.5.3 - Forced control | |
| | 7.5.8 - Screen lock | |
| | 7.5.9 - Modbus TCP/IP | |
| | 7.5.13 - Third-party integration | 7.5.13.1 - Modbus TCP/IP Ext. |
| | | 7.5.13.2 - EEBUS |
| 7.6 - Factory setting service | | |
| 7.7 - Start guide | | |
| 7.8 - Quick start | | |
| 7.9 - Logs | 7.9.1 - Change log | |
| | 7.9.2 - Extended alarm log | |
| | 7.9.3 - Black box | |

¹ Consult the accessory's Installer Manual.

MENU 7.1 - OPERATING SETTINGS

Make operating settings for the system here.

MENU 7.1.1 - HOT WATER

This menu contains advanced settings for hot water operation.

MENU 7.1.1.1 - TEMPERATURE SETTING

Start temperature

Demand mode, small/medium/large

Setting range: 5 - 70 °C

Stop temperature

Demand mode, small/medium/large

Setting range: 5 - 70 °C

Start temp. and stop temp. demand mode, small/medium/large: Here, you set the start and stop temperature of the hot water for the different demand modes (menu 2.2).

MENU 7.1.1.3 - DOMESTIC HW SETTINGS

Setting range: 30 - 85 °C

Here you set the temperature for outgoing water. You can select between high or low flow.

An example of high flow is showering.

An example of low flow is washing up.

MENU 7.1.2 - CIRCULATION PUMPS

This menu contains sub-menus where you can make advanced circulation pump settings.

MENU 7.1.2.1 - OP. MODE HM PUMP GP1

Operating mode

Options: Auto, Intermittent

Auto: The heating medium pump runs according to the current operating mode for SVM S332.

Intermittent: The heating medium pump starts approx. 20 seconds before and stops 20 seconds after the compressor.



NOTE!

The selection "Intermittent" is only available in installations with external supply temperature sensor (BT25).

MENU 7.1.2.2 - PP SP. HEATING MEDIUM GP1

Heating

Auto

Alternative: on/off

Manual speed

Setting range: 1 - 100 %

Minimum permitted speed

Setting range: 1 - 50 %

Maximum permitted speed

Setting range: 80 - 100 %

Speed in wait mode

Setting range: 1 - 100 %

Cooling

Auto

Alternative: on/off

Auto

Alternative: on/off

Manual speed

Setting range: 1 - 100 %

Make settings here for the heating medium pump's speed in the current operating mode, for example in heating or hot water operation. Which operating modes can be changed depends on which accessories are connected.

Heating

Auto: Here, you set whether the heating medium pump is to be regulated automatically or manually.

Manual speed: If you have opted to control the heating medium pump manually, you set the desired pump speed here.

Minimum permitted speed: Here, you can restrict the pump speed to ensure that the heating medium pump is not allowed to operate at a lower speed in auto mode than the set value.

Maximum permitted speed: Here, you can restrict the pump speed to ensure that the heating medium pump is not allowed to operate at a higher speed than the set value.

Speed in wait mode: Here, you set the speed the heating medium pump will have in standby mode. Standby mode occurs when heating or cooling operation is permitted but there is no need for either compressor operation or electric additional heat.

Cooling

Auto: Here, you set whether the pump speed will be regulated automatically or manually.

Auto: Here, you set whether the heating medium pump is to be regulated automatically or manually.

Manual speed: If you have opted to control the heating medium pump manually, you set the desired pump speed here.

MENU 7.1.2.5 - FLOW SETTING CHARGE PUMP

Here, you activate flow calibration for heating medium pump (GP1)

Start flow calibration

A flow calibration can be started manually by pressing the "Start flow calibration" button. The system then schedules the measurement so that it affects regular operations as little as possible. If necessary, the measurement can also be started automatically, for example if deviations or problems are detected.

To optimise the system's performance for both heating and hot water, the product continuously measures the installation's flow characteristics. The results are used to control the charge pump in the most effective and resource-efficient way possible.

MENU 7.1.5 - ADD. HEAT

This menu contains sub-menus where you can make advanced additional heat settings.

MENU 7.1.5.1 - INT ELEC ADD HEAT

Max. set electrical power

Setting range 1x230 V: 0 – 7 kW

Setting range 3x400V: 0 – 9 kW

Max set el power (SG Ready)

Setting range 1x230 V: 0 – 4.5 kW

Setting range 3x400 V: 0 – 6.5 kW

Here you set the max electrical power for the internal electric additional heat in SVM S332, during normal operation and in overcapacity mode (SG Ready).

MENU 7.1.6 - HEATING

This menu contains sub-menus where you can make advanced settings for heating operation.

MENU 7.1.6.1 - MAX DIFF SUPPLY TEMP

Max diff compressor

Setting range: 1 – 25 °C

Max diff additional heat

Setting range: 1 – 24 °C

BT12 offset heat pump 1

Setting range: -5 – 5 °C

Here you set the maximum permitted difference between the calculated and actual supply temperature in the event of compressor or additional heat mode respectively. Max difference additional heat can never exceed max difference compressor

Max diff compressor: If the current supply temperature exceeds the calculated supply line by the set value, the degree minute value is set to 1. The compressor stops when there is only a heating demand.

Max diff additional heat: If "Additional heat" is selected and activated in menu 4.1 and the current supply temperature exceeds the calculated temperature by the set value, the additional heat is forced to stop.

BT12 offset: If there is a difference between the external supply temperature sensor (BT25) and condenser sensor, supply line (BT12), you can set a fixed offset here to compensate for the difference.

MENU 7.1.6.2 - FLOW SETTINGS, CLIMATE SYS

Setting

Options: Radiator, Underfl heating, Rad + Und. heat., Own setting

DOT

Setting range DOT: -40.0 – 20.0 °C

Delta temp at DOT

Setting range dT at DOT: 1.0 – 25.0 °C

The type of heating distribution system the heating medium pump works towards is set here.

dT at DOT is the difference in degrees between supply and return temperatures at design outdoor temperature.

MENU 7.1.6.3 - POWER AT DOT

Manually selected power at DOT

Alternative: on/off

Power at DOT

Setting range: 1 – 1,000 kW

Here, you set the power the property requires at DOT (dimensioned outdoor temperature).

If you choose not to activate "Manually selected power at DOT", the setting is made automatically, i.e. SVM S332 calculates suitable power at DOT.

MENU 7.1.7 - COOLING

This menu contains sub-menus where you can make advanced settings for cooling operation.

MENU 7.1.7.1 - COOLING SETTINGS

Super cooling

Alternative: on/off

Super cooling: With super cooling activated, the installation prioritises the production of cooling using the compressor, while hot water is produced by additional heating in the tank.

MENU 7.1.7.3 - SYSTEM SETTINGS COOLING

Delta at +20°C

Setting range: 3 – 10 degrees

Delta at +40 °C

Setting range: 3 – 20 degrees

Here you set the desired delta between supply and return lines during cooling operation.

MENU 7.1.7.5 - LARGEST DIFF. COOLING

Largest diff. cooling

Setting range: 0 - 4

Here, you set the permitted difference between the supply temperature and the lowest calculated supply temperature for cooling. The selected value determines how far below the value in menu 1.30.5 - "Lowest supply cooling" the supply line may operate before the compressor stops.

MENU 7.1.8 - ALARMS

In this menu, you make settings for the safety measures that SVM S332 will implement in the event of any operational disruption.

MENU 7.1.8.1 - ALARM ACTIONS

Reduce room temperature

Alternative: on/off

Stop producing HW

Alternative: on/off

Audio signal on alarm

Alternative: on/off

Select how you want the SVM S332 to alert you that there is an alarm in the display here.

The different alternatives are that SVM S332 stops producing hot water and/or reduces the room temperature.

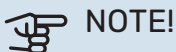

If no alarm action is selected, this can result in higher energy consumption in the event of a malfunction.

MENU 7.1.8.2 - EMERGENCY MODE

Immersion heater output

Setting range 1x230 V: 4 – 4.5 kW

Setting range 3x400 V: 4 – 6.5 kW

Settings are made in this menu for how the additional heat will be controlled in emergency mode.

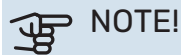

In emergency mode, the display is switched off. If you feel the selected settings are insufficient in emergency mode, you will not be able to change these.

MENU 7.1.9 - LOAD MONITOR

Fuse size

Setting range: 1 – 400 A

Transformer ratio

Setting range: 300 – 3,000

Detect phase sequence

Alternative: on/off

Here, you set fuse size and transformer ratio for the system. The transformer ratio is the factor that is used to convert the metered voltage to current.

Here, you can also check which current sensor is installed on which incoming phase to the property (this requires the current sensors to be installed). Perform the check by selecting "Detect phase sequence".



Search again, if the phase detection fails. The detection process is very sensitive and is easily affected by other appliances in the property.

MENU 7.1.10 - SYSTEM SETTINGS

You make your various system settings for your installation here.

MENU 7.1.10.1 - OPERATING PRIORITISATION

Auto mode

Alternative: on/off

Min

Setting range: 0 – 180 minutes

Here, you select how long the installation will work with each demand, if there are several simultaneous demands.

"Operating prioritisation" is normally set in "Auto mode", but it is also possible to set prioritisation manually.

Auto mode: In auto mode, SVM S332 optimises operating times between different requirements.

Manual: You select how long the installation will work with each demand, if there are several demands at the same time.

If there is only one demand, the installation works with that demand.

If 0 minutes are selected, this means that the demand is not prioritised, but will instead only be activated when there is no other demand.

MENU 7.1.10.2 - AUTO MODE SETTING

Start cooling

Setting range: 15 – 40 °C

Stop heating

Setting range: -20 – 40 °C

Stop additional heat

Setting range: -25 – 40 °C

Filtering time heating

Setting range: 0 – 48 h

Filtering time, cooling

Setting range: 0 – 48 h

Time betw. cooling and heating

Setting range: 0 – 48 h

Cooling/heat sensor

Setting range: None, BT74, Zone 1 - x

Set point value cool/heat sensor

Setting range: 5 – 40 °C

Heating at subnormal room temp

Setting range: 0.5 – 10.0 °C

Cooling at excess room temp

Setting range: 0.5 – 10.0 °C

Start cooling, Stop heating, Stop additional heat: In these menu options, you set the temperatures that the system will use for control in auto mode.

NOTE!

It cannot be set "Stop additional heat" higher than "Stop heating".

Filtering time heating: You can set the time over which the average outdoor temperature is calculated. If you select 0, the current outdoor temperature is used.

Time betw. cooling and heating: Here, you can set how long SVM S332 will wait before it returns to heating mode when the cooling demand has ceased or vice versa.

Cooling/heat sensor: Here, you select the sensor that will be used for cooling/heating. If BT74 is installed, it will be preselected and no other option is possible.

Set point value cool/heat sensor: Here, you can set the indoor temperature at which SVM S332 will shift between heating and cooling operation.

Heating at subnormal room temp: Here, you can set how far the room temperature may drop below the desired temperature before SVM S332 switches to heating operation.

Cooling at excess room temp: Here, you can set how high the room temperature may rise above the desired temperature before SVM S332 switches to cooling operation.

MENU 7.1.10.3 - DEGREE MINUTE SETTINGS

Current value

Setting range: -3,000 – 3,000 DM

Heating, auto

Alternative: on/off

Start compressor

Setting range: -1,000 – (-30) DM

Relative DM start additional heat

Setting range: 100 – 2,000 DM

Diff. between add heat steps

Setting range: 10 – 1,000 DM

DM = degree minutes

Degree minutes (DM) are a measure of the current heating/cooling demand in the property and determine when the compressor or additional heat will start/stop.

NOTE!

Higher value on "Start compressor" gives more compressor starts, which increase wear on the compressor. Too low value can give uneven indoor temperatures.

MENU 7.2 - ACCESSORY SETTINGS

The operating settings for accessories that are installed and activated are made in the sub-menus for this.

MENU 7.2.1 - ADD/REMOVE ACCESSORIES

Here, you tell SVM S332 which accessories are installed.

To identify connected accessories automatically, select "Search for accessories". It is also possible to select accessories manually from the list.

MENU 7.2.19 - PULSE ENERGY METER

Activated

Alternative: on/off

Set mode

Alternatives: Energy per pulse / Pulses per kWh

Energy per pulse

Setting range: 0 – 10000 Wh

Pulses per kWh

Setting range: 1 – 10000

Up to two electricity meters or energy meters (BE6-BE7) can be connected to SVM S332.

Energy per pulse: Here you set the amount of energy to which each pulse will correspond.

Pulses per kWh: Here, you set the number of pulses per kWh that are sent to SVM S332.



TIP!

"Pulses per kWh" is set and presented in whole numbers. If a higher resolution is required, use "Energy per pulse".

MENU 7.3 - MULTI-INSTALLATION

You make settings for the outdoor unit that is connected to SVM S332 in the sub-menus.

MENU 7.3.1 - CONFIGURE

Search installed heat pumps: Here, you can search for, activate or deactivate the connected outdoor unit.

MENU 7.3.2 - INSTALLED HEAT PUMP

Here, you make settings that are specific for the installed outdoor unit.

MENU 7.3.2.1 - HEAT PUMP SETTINGS

Here, you make settings that are specific for the installed outdoor unit.

Cooling permitted

Alternative: on/off

Silent mode permitted

Alternative: on/off

Max. frequency 1

Setting range: 25 Hz -

The setting range depends on the outdoor unit's size and sound requirements.

Max. frequency 2

Setting range: 25 Hz -

The setting range depends on the outdoor unit's size and sound requirements.

Compressor phase

Setting range SVM S332 1 x 230 V: L1, L2, L3

Detect compressor phase

Alternative SVM S332 1 x 230 V: on/off

Current limit

Alternative SVM S332 1 x 230 V: on/off

Max. current

Setting range SVM S332 1 x 230 V: 6 - 32 A

Stop temperature compressor

Setting range -25 - -2 °C

BlockFreq 1 and 2

Setting range, heating: 25 - 120 Hz

Setting range, cooling: 25 - 120 Hz

Cooling permitted: Here, you can set whether the cooling function will be activated for the outdoor unit.

Silent mode permitted: Here, you set whether silent mode will be activated for the outdoor unit. Please note that you now have the option to schedule when silent mode will be active. The function should only be used for limited periods, because AMS 20 might not reach its dimensioned power.

Detect compressor phase: This shows the phase in which the outdoor unit has been detected if you have SVM S332 1x230 V. Phase detection is normally automatic in connection with start-up of the indoor module. This setting can be changed manually.

Current limitation: Here, you set whether the current limitation function will be activated for the outdoor unit, if you have SVM S332 1x230 V. During active function, you can limit the value of the maximum current.

BlockFreq 1-2: Here, you can select the frequency ranges within which the outdoor unit is not permitted to work. This function can be used if certain compressor speeds cause disruptive noise in the house. The setting range varies depending on heat pump model and size.

MENU 7.3.3 - NAME HEAT PUMP

Here, you give a name the outdoor unit that is connected to SVM S332.

MENU 7.4 - SELECTABLE IN/OUTPUTS

Here, you state where the external switch function has been connected, either to one of the AUX inputs on terminal block X28 or to the AUX output on terminal block X27.

MENU 7.4.1 - ENTER A NAME BT37.X

In this menu, you can change the name of your AUX-connected BT37 sensors.

The sensor's designation (BT37.1, BT37.2, BT37.3, BT37.4, BT37.5, BT37.6) will be added to the name you give the sensor.

MENU 7.4.2 - EXTERNAL POWER LIMITING

Power limiting

Setting range: 0.0 - 100.0 kW

For markets where the mains network operator requires dynamic control of the mains network's load.

In this menu, you set the fixed value to which the compressor's and the immersion heater's operating power will be limited.

This function is suitable for use during the hours when the property is using the most electricity.

MENU 7.5 - TOOLS

Here, you can find functions for maintenance and service work.

MENU 7.5.1 - HEAT PUMP, TEST



CAUTION!

This menu and its sub-menus are intended for testing the outdoor unit.

Use of this menu for other reasons may result in your installation not functioning as intended.

MENU 7.5.2 - UNDERFLOOR DRYING FUNCTION

Length period 1 - 7

Setting range: 0 - 30 days

Temperature period 1 - 7

Setting range: 15 - 70 °C

Set the function for under floor drying here.

You can set up to seven time periods with different calculated supply temperatures. If fewer than seven periods are to be used, set the remaining periods to 0 days.

When the underfloor drying function has been activated, a counter is displayed showing the number of full days the function has been active. The function counts degree minutes in the same way as during normal heating operation, but for the supply temperatures that are set for the respective period.



TIP!

If operating mode "Add. heat only"⁶ is to be used, select it in menu 4.1.

Once set under floor drying periods have finished, reset menu 4.1.

MENU 7.5.3 - FORCED CONTROL

Here you can force control the various components in the installation. The most important safety functions remain active however.



CAUTION!

Forced control is only intended to be used for troubleshooting purposes. Using the function in any other way may cause damage to the components in your installation.

MENU 7.5.8 - SCREEN LOCK

Here, you can choose to activate the screen lock for SVM S332. During activation, you will be asked to enter the required code (four digits). The code is used when:

- deactivating the screen lock.
- changing the code.
- starting up the display when it has been inactive.
- restarting/starting up SVM S332.

⁶ Only SVM S332 3x400 V with shunt valve QN11.

MENU 7.5.9 - MODBUS TCP/IP

Alternative: on/off

Here, you activate Modbus TCP/IP. Read more on page 73.

MENU 7.5.13 - THIRD-PARTY INTEGRATION

Here, you manage connections to external services.

MENU 7.5.13.1 - MODBUS TCP/IP EXT.

Alternative: on/off

Here, you activate Modbus TCP/IP for external services.

MENU 7.5.13.2 - EEBUS

Alternative: on/off

Here, you can activate EEBUS communication.

MENU 7.6 - FACTORY SETTING SERVICE

Here, you can reset all settings (including settings available to the user) to factory values

Here, you can also choose to reset the connected outdoor unit to the factory settings.



CAUTION!

When resetting, the start guide is displayed the next time SVM S332 restarts.

MENU 7.7 - START GUIDE

When SVM S332 is started for the first time, the start guide is automatically activated. From this menu, you can start it manually.

MENU 7.8 - QUICK START

You can quick start the compressor here.

One of the following demands for the compressor must exist for quick start:

- heating
- hot water
- cooling



NOTE!

For it to be possible to quick-start the compressor, it must have reached the correct temperature. It can take up to 30 minutes to preheat the compressor.



NOTE!

Too many quick starts in a short space of time may damage the compressor and its auxiliary equipment.

MENU 7.9 - LOGS

Under this menu, there are logs that collect information about alarms and changes made. The menu is intended to be used for troubleshooting.

MENU 7.9.1 - CHANGE LOG

Read off any previous changes to the control system here.



CAUTION!

The change log is saved at restart and remains unchanged after factory setting.

MENU 7.9.2 - EXTENDED ALARM LOG

This log is intended to be used for troubleshooting.

MENU 7.9.3 - BLACK BOX

Via this menu, it is possible to export all logs (Change log, Extended alarm log) to USB. Connect a USB memory and select the log(s) you want to export.

Service

Service actions



CAUTION!

Servicing and maintenance should only be carried out by persons with the necessary expertise.

When replacing components on SVM S332 only replacement parts from NIBE may be used.

EMERGENCY MODE



CAUTION!

Do not start the system before filling up with water. Components in the system could be damaged.

Emergency mode is used in event of operational interference and in conjunction with service.

When the emergency mode is active, the status lamp is yellow.

You can activate the emergency mode both when SVM S332 is running and when it is switched off.

To activate when SVM S332 is running: press and hold the on/off button (SF1) for 2 seconds and select "Emergency mode" from the shutdown menu.

To activate emergency mode when SVM S332 is switched off: press and hold the on/off button (SF1) for 5 seconds. (Deactivate the emergency mode by pressing once).

When SVM S332 is put in emergency mode, the display is switched off and the most basic functions are active:

- The immersion heater works to maintain the calculated supply temperature. If there is no outdoor temperature sensor (BT1), the immersion heater works to maintain the maximum supply temperature, set in menu 1.30.6 - "Highest supply heat"¹.
- Only the circulation pumps and electric additional heat are active. Max output for the immersion heater in emergency mode, limited according to the setting in menu 7.1.8.2 - "Emergency mode".

¹ Only SVM S332 3x400 V with shunt valve QN11.

DRAINING THE HOT WATER

Draining the hot water heat exchanger and the storage tank for hot water.

1. Close the shut-off valves to the climate system.
2. Connect a hose to the drain valve for heating medium (QM1).
3. Open the vent valves (QM23.2 – QM23.5).
4. Open the drain valve for the heating medium (QM1).



TIP!

If you only want to empty the hot water heat exchanger, you only need to drain approx 10 litres of water.

DESCALING THE HOT WATER HEAT EXCHANGER

1. Drain the hot water heat exchanger (EP3), see section "Draining the hot water". The siphon principle is used to drain the hot water heat exchanger.
2. Mix water and citric acid into a solution. Use a 5–10 % concentration of citric acid.
3. Pour the solution into the hot water heat exchanger. Make sure the hot water heat exchanger is completely filled and that there are no air pockets.
4. Allow the solution to work in the hot water heat exchanger for up to 1–2 hours, depending on the extent of the deposits. Avoid prolonged exposure, because the hot water heat exchanger could sustain damage.
5. Check at regular intervals (e.g. every 30 minutes) to see how the descaling is progressing.
6. After the solution has been allowed to work, rinse the hot water heat exchanger thoroughly with clean water to ensure that the citric acid solution is flushed out.

DRAINING THE CLIMATE SYSTEM

In order to carry out service on the climate system, it may be easier to drain the system first.

NOTE!

This does not drain the UKV vessel. When draining the UKV vessel, a siphon needs to be used in the heating medium connection, supply (XL1). All servicing can be carried out without draining the UKV vessel.

CAUTION!

There may be some hot water, risk of scalding.

1. Connect a hose to the drain valve for heating medium (QM1).
2. Open the vent valves (QM23.2 – QM23.5).
3. Open the drain valve for the heating medium (QM1).

REMOVING A UNIT

To remove a unit or replace the outdoor unit, the following steps need to be taken:

1. Set the machine in "Add. heat only" in menu 4.1 – Operating mode.
2. Select "Pump down start" in menu 7.3.2 – Installed heat pump.
3. When the compressor has finished working, the transfer of the refrigerant is complete.

DATA FOR TEMPERATURE SENSOR IN THE INDOOR UNIT

| Temperature (°C) | Resistance (kOhm) | Voltage (VDC) |
|------------------|-------------------|---------------|
| -10 | 56.20 | 3.047 |
| 0 | 33.02 | 2.889 |
| 10 | 20.02 | 2.673 |
| 20 | 12.51 | 2.399 |
| 30 | 8.045 | 2.083 |
| 40 | 5.306 | 1.752 |
| 50 | 3.583 | 1.426 |
| 60 | 2.467 | 1.136 |
| 70 | 1.739 | 0.891 |
| 80 | 1.246 | 0.691 |

DATA FOR SENSOR IN AMS 20-6

Tho-D

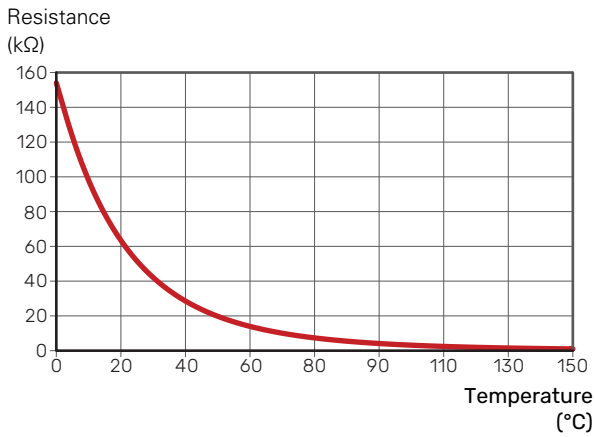

DATA FOR SENSOR IN AMS 20-10

Tho-D

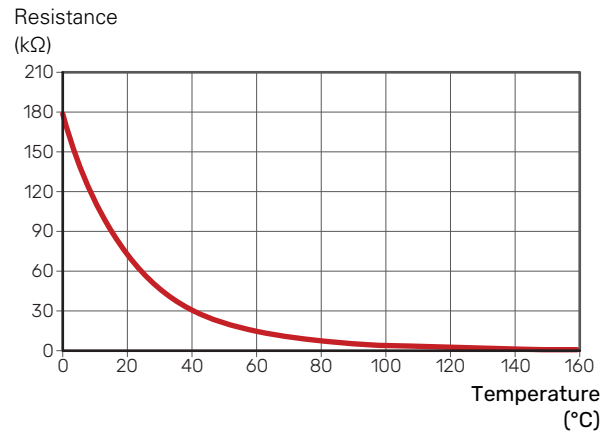

Tho-A, R

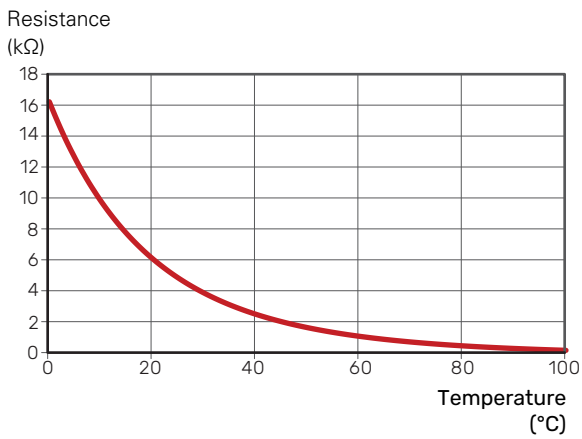

Tho-S, Tho-R1, Tho-R2

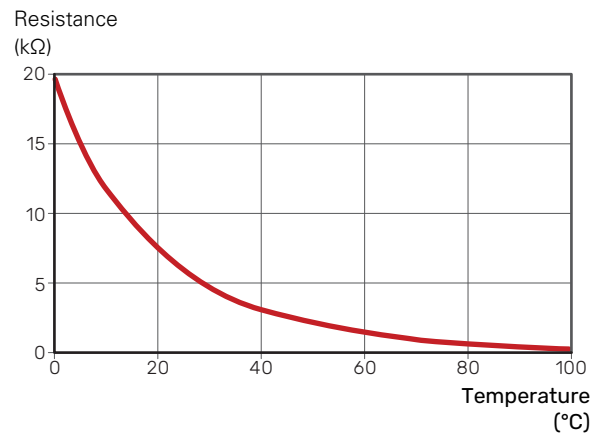

BT28 (Tho-A)

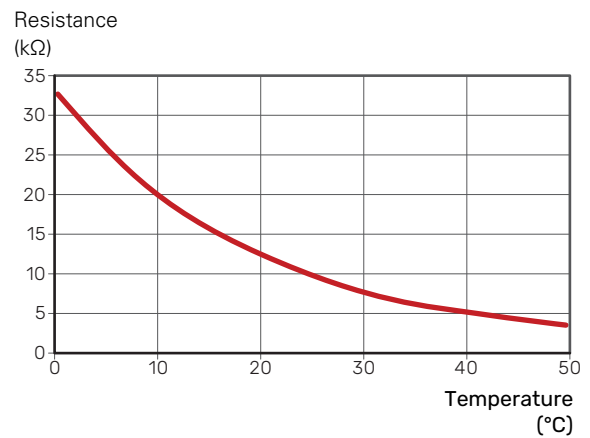

USB SERVICE OUTLET

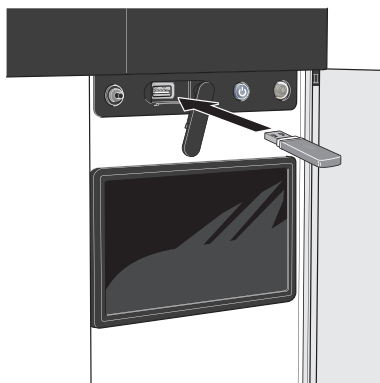

When a USB memory is connected, a new menu (menu 8) appears in the display.

Menu 8.1 - "Update the software"

You can update the software with a USB memory in menu 8.1 - "Update the software".



CAUTION!

In order to update using a USB memory, the memory must contain a file with software for SVM S332 from NIBE.

Software for SVM S332 can be downloaded from myuplink.com.

One or more files are shown in the display. Select a file and press "OK".



TIP!

A software update does not reset the menu settings in SVM S332.



NOTE!

If the update is interrupted before it is complete (e.g. during a power cut), the software is automatically restored to the previous version.

Menu 8.2 - Logging

Interval

Setting range: 1 s – 60 min

Here you can choose how current measurement values from SVM S332 should be saved onto a log file on the USB memory.

1. Set the desired interval between loggings.
2. Select "Start logging".
3. The relevant measurement values from SVM S332 are now saved in a file on the USB memory at the set interval until you select "Stop logging".



NOTE!

Select "Stop logging" before removing the USB memory.

Logging floor drying

Here you can save a floor drying log on the USB memory and in this way see when the concrete slab reached the correct temperature.

- Make sure that "Underfloor drying function" is activated in menu 7.5.2.
- A log file is now created, where the temperature and the immersion heater output can be read off. Logging continues until "Underfloor drying function" is stopped.



NOTE!

Close "Underfloor drying function" before removing the USB memory.

Menu 8.3 - Manage settings

Save settings

Alternative: on/off

Display backup

Alternative: on/off

Restore settings

Alternative: on/off

In this menu, you save/upload menu settings to/from a USB memory stick.

Save settings: Here, you save menu settings in order to restore them later or to copy the settings to another SVM S332.

Display backup: Here, you save both menu settings and measurement values, such as energy data.



NOTE!

When you save menu settings to the USB memory, you replace any previously saved settings on the USB memory.

Restore settings: Here, you upload all menu settings from the USB memory stick.



NOTE!

Resetting of menu settings from the USB memory cannot be undone.

Manual restoring of software

If you want to restore the software to the previous version:

1. Switch off SVM S332 via the shutdown menu. The status lamp goes out, off/on button light up blue.
2. Press the on/off button once.

- When the on/off button changes colour from blue to white, press and hold the on/off button.
- When the status lamp changes to green, release the on/off button.

NOTE!

If the status lamp should turn yellow at any time, SVM S332 has ended up in emergency mode and the software has not been restored.

TIP!

If you have a previous version of the software on your USB memory, you can install that instead of manually restoring the version.

Menu 8.5 - Export energy logs

From this menu, you can save your energy logs to a USB memory.

MODBUS TCP/IP

SVM S332 has built-in support for Modbus TCP/IP, which is activated in menu 7.5.9 - "Modbus TCP/IP".

TCP/IP settings are set in menu 5.2 - "Network settings". Only connections from IP addresses within the local address space as specified below:

10.0.0.0 - 10.255.255.255

172.16.0.0 - 172.31.255.255

192.168.0.0 - 192.168.255.255

Modbus protocol uses port 502 for communication.

| Readable | ID | Description |
|-------------------|------|--------------------------|
| Read | 0x04 | Input Register |
| Read writable | 0x03 | Holding Register |
| Writable multiple | 0x10 | Write multiple registers |
| Writable single | 0x06 | Write single register |

Available registers are shown in the display for the current product and its installed and activated accessories.

Export register

- Insert a USB memory.
- Go to menu 7.5.9 and choose "Export most used registers" or "Export all registers". These will then be stored on the USB memory in CSV format. (These options are only shown when a USB memory is inserted in the display).

IP address restriction

- Go to menu 7.5.9 and choose IP address restriction.
- Enter the IP address that is allowed to communicate with the system.

CAUTION!

Modbus/TCP communication over the open internet is very risky and is not recommended.

MAC address

Go to menu 3.1.13 - "Connections" to see the MAC address.

Reading only

Reading Modbus only means that no values can be sent to the system, only reading of values is possible.

Local REST API

Go to menu 7.1.15 - "Local REST API" to activate the function. For more information see "myUplink".

Disturbances in comfort

In most cases, the SVM S332 notes a malfunction and indicates this with alarms and presents action instructions in the display.

Info-menu

All the indoor module's measured values are gathered under menu 3.1 - "Operating info" in the indoor module's menu system. Examining the values in this menu can often make it easier to identify the source of the fault.

Manage alarm

In the event of an alarm, a malfunction has occurred and the status lamp shines with a steady red light. You receive information about the alarm in the smartguide on the display.

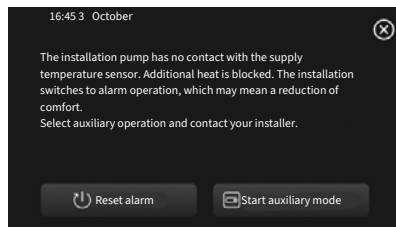
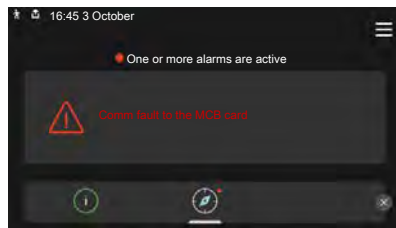

ALARM

In the event of an alarm with a red status lamp, a malfunction has occurred that SVM S332 cannot remedy itself. On the display, you can see what type of alarm it is and reset it.

In many cases, it is sufficient to select "Reset alarm" for the installation to revert to normal operation.

If a white light comes on after selecting "Reset alarm", the alarm has been remedied.

"Auxiliary operation" is a type of emergency mode. This means that the installation tries to produce heat and/or hot water, even though there is some kind of problem. This could mean that the compressor is not in operation. In this case, any electric additional heating produces heat and/or hot water.

NOTE!

To select "Start auxiliary mode", an alarm action must be selected in the menu 7.1.8.1 - "Alarm actions".

NOTE!

Selecting "Start auxiliary mode" is not the same as correcting the problem that caused the alarm. Therefore, the status lamp will remain red.

Troubleshooting

If the operational interference is not shown in the display the following tips can be used:

BASIC ACTIONS

Start by checking the following items:

- Group and main fuses of the building.
- The building's earth circuit breaker.
- Indoor unit's RCD.
- Miniature circuit-breaker for SVM S332 (FC1)¹.
- Temperature limiter for SVM S332 (FQ10).
- Correctly set load monitor.

¹ Only SVM S332 1x230 V.

LOW HOT WATER TEMPERATURE OR A LACK OF HOT WATER

- Closed or throttled externally mounted filling valve for the hot water.
 - Open the valve.
- Mixing valve (if there is one installed) set too low.
 - Adjust the mixer valve.
- SVM S332 in incorrect operating mode.
 - Enter menu 4.1 - "Operating mode". If "Auto" mode is selected, select a higher value for "Stop additional heat" in menu 7.1.10.2 - "Auto mode setting".
 - Hot water is produced with SVM S332 in "Manual" mode. If there is no outdoor unit, "Additional heat" must ⁷ be activated.
- Large hot water consumption.
 - Wait until the hot water has heated up. Temporarily increased hot water capacity can be activated in the "Hot water" home screen, in menu 2.1 - "More hot water" or via myUplink.
- Too high domestic water flow.
 - Reduce the domestic water flow, see technical specifications for the hot water capacity in the "Technical specifications" section.
- Too low hot water setting.
 - Enter menu 2.2 - "Hot water demand" and select a higher demand mode.
- Low hot water access with the "Smart Control" function active.

⁷ Only SVM S332 with shunt valve QN11.

- If the hot water usage has been low for an extended period of time, less hot water than normal will be produced. Activate "More hot water" via the "Hot water" home screen, in menu 2.1 - "More hot water" or via my-Uplink.
- The supply temperature for the hot water is set too low.
 - Adjust the supply temperature in menu 7.1.1.3 - "Domestic HW settings".
- Too low or no operating prioritisation of hot water.
 - Enter menu 7.1.10.1 - "Operating prioritisation" and increase the time for when hot water is to be prioritised. Note that, if the time for hot water is increased, the time for heating production is reduced, which can give lower/uneven room temperatures.
- "Holiday" activated in menu 6.
 - Enter menu 6 and deactivate.
- The hot water heat exchanger is clogged
 - Clean the limescale deposits from the hot water heat exchanger (EP3) using water and citric acid. See how to do this in section "Descaling the hot water heat exchanger".

LOW ROOM TEMPERATURE

- Closed thermostats in several rooms.
 - Set the thermostats to max in as many rooms as possible. Adjust the room temperature via the "Heating" home screen, rather than turning down the thermostats.
- SVM S332 in incorrect operating mode.
 - Enter menu 4.1 - "Operating mode". If "Auto" mode is selected, select a higher value for "Stop heating" in menu 7.1.10.2 - "Auto mode setting".
 - If mode "Manual" is selected, select "Heating". If this is not enough, also select "Additional heat¹".

¹ Only SVM S332 3x400 V with shunt valve QN11.
- Too low set value on the automatic heating control.
 - Adjust via the smart guide or home screen "Heating"
 - If the room temperature is only low in cold weather, the curve slope in menu 1.30.1 - "Curve, heating" may need to be adjusted upwards.
- Too low or no operating prioritisation of heat.
 - Enter menu 7.1.10.1 - "Operating prioritisation" and increase the time for when heating is to be prioritised. Note that if the time for heating is increased, the time for hot water production is reduced, which can give a smaller amount of hot water.
- "Holiday" activated in menu 6 - "Scheduling".
 - Enter menu 6 and deactivate.
- External switch for changing room temperature activated.
 - Check any external switches.

- Air in the climate system.
 - Vent the climate system.
- Closed valves to the climate system.
 - Open the valves.

HIGH ROOM TEMPERATURE

- Too high set value on the automatic heating control.
 - Adjust via the smart guide or home screen "Heating"
 - If the room temperature is only high in cold weather, the curve slope in menu 1.30.1 - "Curve, heating" may need to be adjusted downwards.
- External switch for changing room temperature activated.
 - Check any external switches.
- Value set too low on the automatic cooling control.
 - Adjust via the Smartguide or home screen "Cooling".
 - If the room temperature is only high in cold weather, the curve slope in menu 1.30.2 - "Curve, cooling" may need to be adjusted downwards.

UNEVEN ROOM TEMPERATURE.

- Incorrectly set heating curve.
 - Fine-tune the heating curve in menu 1.30.1.
- Too high set value on "DOT"..
 - Enter menu 7.1.6.2 - "flow set. climate system" and reduce the value of "DOT".
- Uneven flow over the radiators.
 - Adjust the flow distribution over the radiators.

LOW SYSTEM PRESSURE

- Not enough water in the climate system.
 - Fill the climate system with water and check for leaks (see chapter "Filling and venting").

THE OUTDOOR UNIT'S COMPRESSOR DOES NOT START

- There is no heating or hot water demand, nor cooling demand.
 - SVM S332 does not call on heating, hot water or cooling.
- Compressor blocked due to the temperature conditions.
 - Wait until the temperature is within the product's working range.
- Minimum time between compressor starts has not been reached.
 - Wait for at least 30 minutes and then check if the compressor has started.
- Alarm tripped.
 - Follow the display instructions.

Alarm list

| Alarm SVM S332 | Alarm text on the display | Description | May be due to |
|----------------|------------------------------------|---|--|
| 103 | Sensor fault BT3 | Sensor fault, Sensor incoming water in SVM S332 (BT3). | <ul style="list-style-type: none"> Open circuit or short circuit on sensor input Sensor does not work Defective communication board AA23 in SVM S332 |
| 108 | Sensor fault BT12 | Sensor fault, Sensor outgoing water in SVM S332 (BT12). | <ul style="list-style-type: none"> Open circuit or short circuit on sensor input Sensor does not work Defective communication board AA23 in SVM S332 |
| | Sensor fault BT15 | Sensor fault, Sensor liquid line in SVM S332 (BT15). | <ul style="list-style-type: none"> Open circuit or short circuit on sensor input Sensor does not work Defective communication board AA23 in SVM S332 |
| 215 | High condenser out | Too high temperature out from the condenser. Self-resetting. | <ul style="list-style-type: none"> Low flow during heating operation Too high set temperatures |
| 216 | High condenser in | Too high temperature into the condenser. Self-resetting. | <ul style="list-style-type: none"> Temperature generated by another heat source |
| 221 | Defrosting in progress | not an alarm, but an operating status instead. | <ul style="list-style-type: none"> Set when the heat pump runs the defrosting procedure |
| 229 | HP alarm | The high pressure switch (63H1) deployed 5 times within 60 minutes or for 60 minutes continuously. | <ul style="list-style-type: none"> Insufficient air circulation or blocked heat exchanger Open circuit or short circuit on input for high pressure switch (63H1) Defective high pressure switch Expansion valve not connected correctly Service valve closed Defective control board in AMS 20 Low or no flow during heating operation Defective circulation pump Defective fuse, F(4A) |
| 230 | LP alarm | Too low a value on the low pressure sensor (LPT) 3 times within 60 minutes. | <ul style="list-style-type: none"> Open circuit or short circuit on input for low pressure sensor Defective low pressure sensor (LPT) Defective control board in AMS 20 Open circuit or short circuit on input for suction gas sensor (Tho-S) Defective suction gas sensor (Tho-S) Lack of refrigerant |
| 232 | OU Com. error | Communication between the control board and the communication board is interrupted. There must be 22 volt direct current (DC) at the switch CNW2 on the control board (PWB1). | <ul style="list-style-type: none"> Any circuit breakers for AMS 20 off Incorrect cable routing Damaged cable PWB1-board defective Communication board defective Lack of refrigerant. |
| 233 | Fan alarm | Deviations in the fan speed in AMS 20. | <ul style="list-style-type: none"> The fan cannot rotate freely Defective control board in AMS 20 Defective fan motor Fuse (F2) blown |
| 238 | Continuously high hot gas | Temperature deviation on the hot gas sensor (Tho-D) twice within 60 minutes or for 60 minutes continuously. | <ul style="list-style-type: none"> Sensor does not work Insufficient air circulation or blocked heat exchanger If the fault persists during cooling, there may be an insufficient amount of refrigerant. Defective control board in AMS 20 |
| 247 | Communication error | Communication fault with accessory board | <ul style="list-style-type: none"> AMS 20 not powered Fault in the communication cable. |
| 251 | High temperature in heat exchanger | Temperature deviation on the heat exchanger sensor (Tho-R1/R2) five times within 60 minutes or for 60 minutes continuously. | <ul style="list-style-type: none"> Sensor does not work Insufficient air circulation or blocked heat exchanger Defective control board in AMS 20 Too much refrigerant |
| 252 | Power transistor too hot | When IPM (Intelligent power module) displays FO-signal (Fault Output) five times during a 60-minute period. | <ul style="list-style-type: none"> Can occur when 15V power supply to the inverter PCB is unstable. |
| 253 | Inverter error | Voltage from the inverter outside the parameters four times within 30 minutes. | <ul style="list-style-type: none"> Incoming power supply interference Service valve closed Insufficient amount of refrigerant Compressor fault Defective circuit board for inverter in AMS 20 |

| Alarm SVM S332 | Alarm text on the display | Description | May be due to |
|----------------|--------------------------------------|--|--|
| 254 | Inverter error | Communication between circuit board for inverter and control board broken. | <ul style="list-style-type: none"> • Open circuit in connection between boards • Defective circuit board for inverter in AMS 20 • Defective control board in AMS 20 |
| 255 | Inverter error | Continuous deviation on power transistor for 15 minutes. | <ul style="list-style-type: none"> • Defective fan motor • Defective circuit board for inverter in AMS 20 |
| 256 | Not enough refrigerant | Not enough refrigerant is detected on start-up in cooling mode. | <ul style="list-style-type: none"> • Service valve closed • Loose connection sensor (BT15, BT3) • Defective sensor (BT15, BT3) • Too little refrigerant |
| 257 | Inverter error | Failed start for compressor | <ul style="list-style-type: none"> • Defective circuit board for inverter in AMS 20 • Defective control board in AMS 20 • Compressor fault |
| 258 | Inverter error | Overcurrent, Inverter A/F module | <ul style="list-style-type: none"> • Sudden power failure |
| 260 | Cold outdoor air | Temperature of BT28 (Tho-A) below the set value that permits operation | <ul style="list-style-type: none"> • Cold weather conditions • Sensor fault |
| 261 | Hot outdoor air | Temperature of BT28 (Tho-A) above the value that permits operation | <ul style="list-style-type: none"> • Warm weather conditions • Sensor fault |
| 147 | Sensor fault Tho-R | Sensor fault, heat exchanger in AMS 20 (Tho-R). | <ul style="list-style-type: none"> • Open circuit or short circuit on sensor input • Sensor does not work • Defective control board in AMS 20 |
| 148 | Sensor fault Tho-A | Sensor fault, outdoor temperature sensor in AMS 20 BT28 (Tho-A). | <ul style="list-style-type: none"> • Open circuit or short circuit on sensor input • Sensor does not work • Defective control board in AMS 20 |
| 149 | Sensor fault Tho-D | Sensor fault, hot gas in AMS 20 (Tho-D). | <ul style="list-style-type: none"> • Open circuit or short circuit on sensor input • Sensor does not work • Defective control board in AMS 20 |
| 150 | Sensor fault Tho-S | Sensor fault, suction gas in AMS 20 (Tho-S). | <ul style="list-style-type: none"> • Open circuit or short circuit on sensor input • Sensor does not work • Defective control board in AMS 20 |
| 151 | Sensor fault LPT | Sensor fault, low-pressure sensor in AMS 20. | <ul style="list-style-type: none"> • Open circuit or short circuit on sensor input • Sensor does not work • Defective control board in AMS 20 • Fault in the refrigerant circuit |
| 269 | Non-compatible outdoor air heat pump | Outdoor unit and indoor unit/control unit do not function together properly due to technical parameters. | <ul style="list-style-type: none"> • Outdoor module and indoor module/control module are not compatible. |

Accessories

Detailed information about the accessories and complete accessories list available at nibe.eu.

Not all accessories are available on all markets.

AUTOMATIC GAS SEPARATOR AGS 10

This automatic gas separator needs to be installed when the pipe length between the outdoor unit NIBE AMS 20-10 and indoor unit SVM S332 is longer than 15 metres. In cases where additional filling with refrigerant is required.

Part no. 067 829

ENERGY MEASUREMENT KIT EMK 300

This accessory is installed externally and used to measure the amount of energy that is supplied to the hot water/heating/cooling for the house.

Part no. 067 314

EXTERNAL ELECTRIC ADDITIONAL HEAT ELK

These accessories require accessories card AXC 40 (step controlled addition).

ELK 5

Electric heater
5 kW, 1 x 230 V
Part no. 069 025

ELK 15

15 kW, 3 x 400 V
Part no. 069 022

ELK 42

42 kW, 3 x 400 V
Part no. 067 075

ELK 8

Electric heater
8 kW, 1 x 230 V
Part no. 069 026

ELK 26

26 kW, 3 x 400 V
Part no. 067 074

ELK 213

7–13 kW, 3 x 400 V
Part no. 069 500

EXTRA SHUNT GROUP ECS

This accessory is used when SVM S332 is installed in houses with two or more different climate systems that require different supply temperatures.

ECS 40

Max 80 m²
Part no 067 287

ECS 41

Approx. 80–250 m²
Part no 067 288

HUMIDITY SENSOR HTS 40

This accessory is used to show and regulate humidity and temperatures during both heating and cooling operation.

Part no. 067 538

HRV UNIT ERS

This accessory is used to supply the accommodation with energy that has been recovered from the ventilation air. The unit ventilates the house and heats the supply air as necessary.

ERS S10-400¹

Part no. 066 163

ERS 20-250²

Part no. 066 068

ERS 30-400³

Part no. 066 165

ERS S40-400

Part no. 066 242

¹ A preheater may be required.

² A preheater may be required.

³ A preheater may be required.

BASE EXTENSION EF 45

This accessory can be used to create a larger area under SVM S332.

Part no. 067 152

AUXILIARY RELAY

Auxiliary relay is used to control external 1 to 3 phase loads, such as, for example, oil burners, immersion heaters and circulation pumps.

HR 10

Recommended max fuse for control current 10 A.
Part no 067 309

COMMUNICATION MODULE FOR SOLAR ELECTRICITY EME 20

EME 20 is used to enable communication and control between inverters for solar cells from NIBE and SVM S332.

Part no. 057 215

CONDENSATION WATER PIPE KVR

Condensation water pipe with heating cable, different lengths.

KVR 12-10

1 metres
Part no. 067 932

KVR 12-30

3 metres
Part no. 067 933

KVR 12-60

6 metres
Part no. 067 934

REFRIGERANT PIPE KIT

Refrigerant pipe, different lengths.

RPK 10-120

1/4" / 1/2", 12 metres, insulated, for SVM S332-6

Part no. 067 889

RPK 12-120

1/4" / 5/8", 12 metres, insulated, for SVM S332-10

Part no. 067 830

ROOM UNIT RMU S40

The room unit is an accessory with a built-in room temperature sensor and humidity sensor, which allows the control and monitoring of SVM S332 to be carried out in a different part of the property to where it is located.

Part no. 067 650

SOLAR PACKAGE NIBE PV

NIBE PV is a modular system comprising solar panels, assembly parts and inverters, which is used to produce your own electricity.

ACCESSORY CARD AXC 40

This accessory is used to enable connection and control of shunt-controlled additional heat, step-controlled additional heat or external circulation pump.

Part no. 067 060

WIRELESS ACCESSORIES

It is possible to connect wireless accessories to SVM S332, e.g. room, humidity, CO₂ sensors.

BUFFER VESSEL UKV

A buffer vessel is an accumulator tank that is suitable for connection to a heat pump or another external heat source, and can have several different applications.

UKV 40

Part no. 088 470

UKV 100

Part no. 088 207

UKV 200

Part no. 080 300

UKV 300

Part no. 080 301

UKV 200 Cooling

Part no. 080 321

UKV 300 Cooling

Part no. 080 330

TOP CABINET TOC 30

Top cabinet, which conceals any pipes/ventilation ducts.

Height 245 mm

Part no. 067 517

Height 345 mm

Part no. 067 518

Height 385-635 mm

Part no. 067 519

Technical data

Dimensions

Dimensions, indoor unit

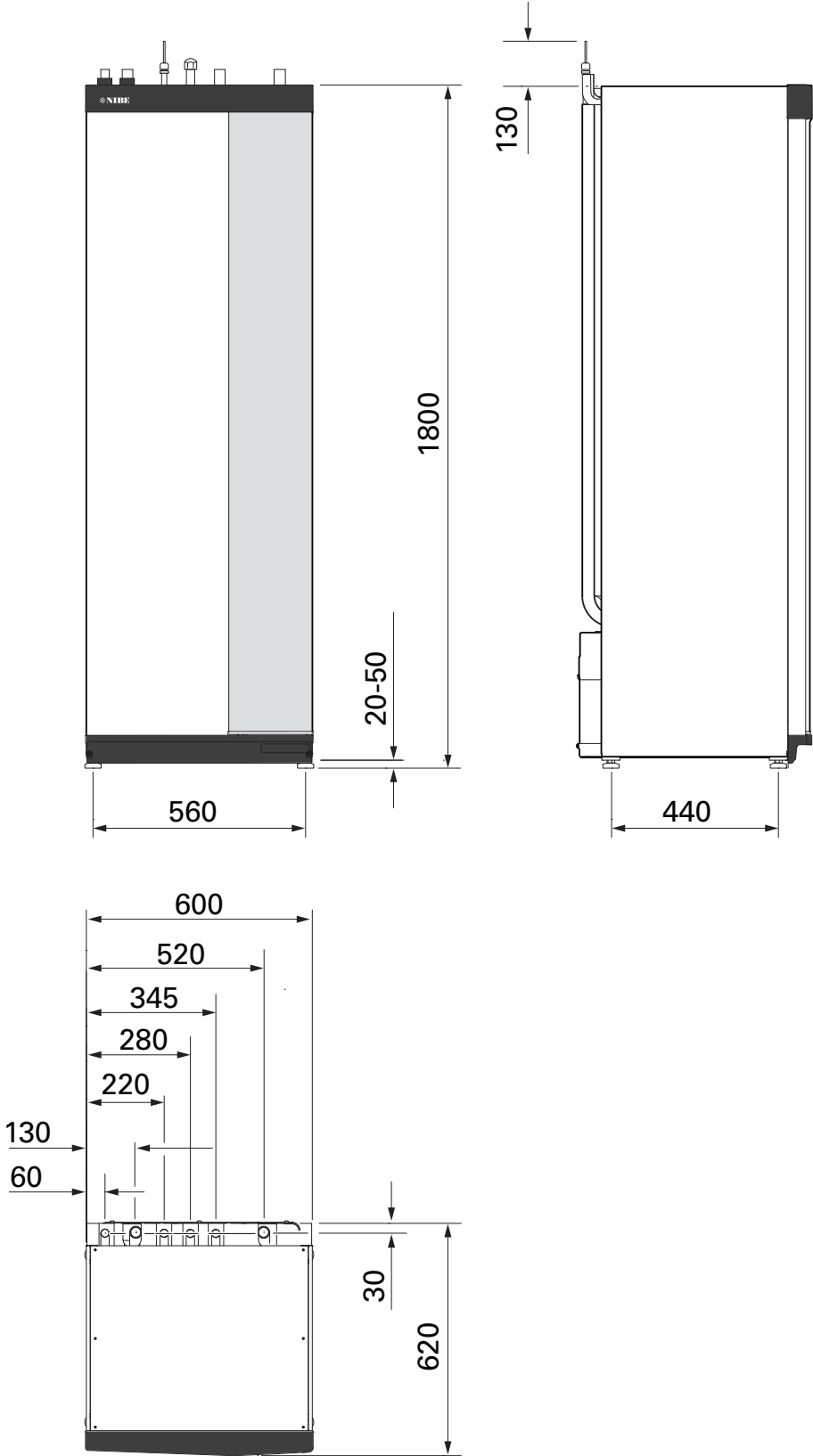

Dimensions, outdoor unit

AMS 20-6

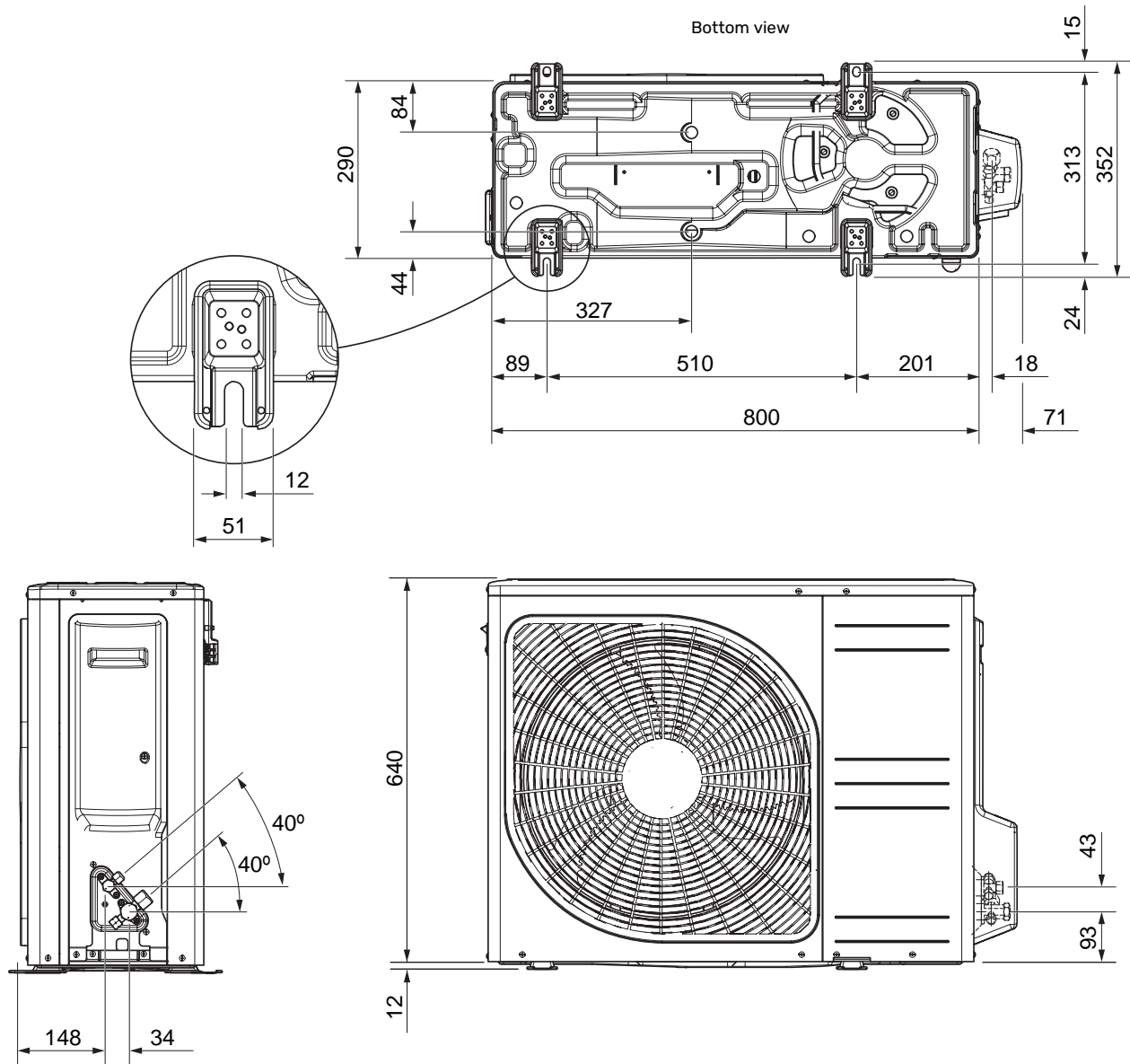

Sound levels

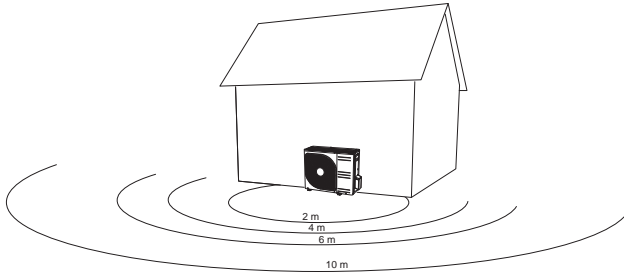

AMS 20 is usually placed next to a house wall, which gives a directed sound distribution that should be considered. Accordingly, you should always attempt to find a placement on the side that faces the least sound sensitive neighbouring area.

The sound pressure levels are further affected by walls, bricks, differences in ground level, etc and should therefore only be seen as guide values.

| | | Sound power ¹ | Sound pressure at distance (m) ² | | | | | | | | | |
|-----------|-------------------------------------|--------------------------|---|------|------|------|------|------|------|------|------|------|
| | | | 1 | 2 | 3 | 4 | 5 | 6 | 7 | 8 | 9 | 10 |
| AMS 20-6 | Nominal sound value | 54 | 49.0 | 43.0 | 39.5 | 37.0 | 35.0 | 33.5 | 32.1 | 31.0 | 29.9 | 29.0 |
| | Max. sound value | 62 | 57.0 | 51.0 | 47.5 | 45.0 | 43.0 | 41.5 | 40.1 | 39.0 | 37.9 | 37.0 |
| | Max. sound value, silent mode | 54 | 48.0 | 42.0 | 38.5 | 36.0 | 34.0 | 32.5 | 31.1 | 30.0 | 28.9 | 28.0 |
| AMS 20-10 | Nominal sound value | 54 | 49.0 | 43.0 | 39.5 | 37.0 | 35.0 | 33.5 | 32.1 | 31.0 | 29.9 | 29.0 |
| | Max. sound value | 65 | 60.0 | 54.0 | 50.5 | 48.0 | 46.0 | 44.5 | 43.1 | 42.0 | 40.9 | 40.0 |
| | Max. sound value, silent mode 60 Hz | 54 | 49.0 | 43.0 | 39.5 | 37.0 | 35.0 | 33.5 | 32.1 | 31.0 | 29.9 | 29.0 |

¹ Sound power level, $L_w(A)$, according to EN12102

² Sound pressure calculated according to directivity factor $Q=4$

Installation requirements

| SVM S332 | SVM S332-6 | SVM S332-10 |
|---|------------|-------------|
| Compatible outdoor module | AMS 20-6 | AMS 20-10 |
| Requirements | | |
| Max system pressure heating medium | 0.3 (3) | |
| Highest recommended supply/return temperature at dimensioned outdoor temperature | 55 / 45°C | |
| Max flow line temperature with compressor | 58 °C | 60 °C |
| Min supply temperature cooling | 7 °C | |
| Max supply temp. cooling | 25 °C | |
| Min flow, climate system, 100 % circulation pump speed (defrosting flow) | 0.19 l/s | |
| Recommendations | | |
| Heating/cooling: Min. circulating volume of climate system, in addition to internal buffer vessel (52 litres) | 0 l | 0 l |
| Under floor heating: Min. circulating volume of climate system, in addition to internal buffer vessel (52 litres) | 0 l | 30 l |
| Max flow, climate system | 0.29 l/s | 0.38 l/s |
| Min flow, heating system | 0.09 l/s | 0.12 l/s |
| Min flow, cooling system | 0.11 l/s | 0.16 l/s |

Technical specifications

WORKING RANGE, HEATING

AMS 20-6

The supply temperature is permitted to be lower for a short period, e.g. at start-up.

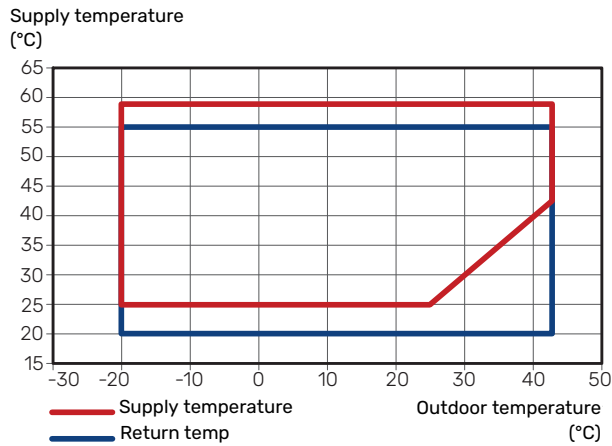

AMS 20-10

The supply temperature is permitted to be lower for a short period, e.g. at start-up.

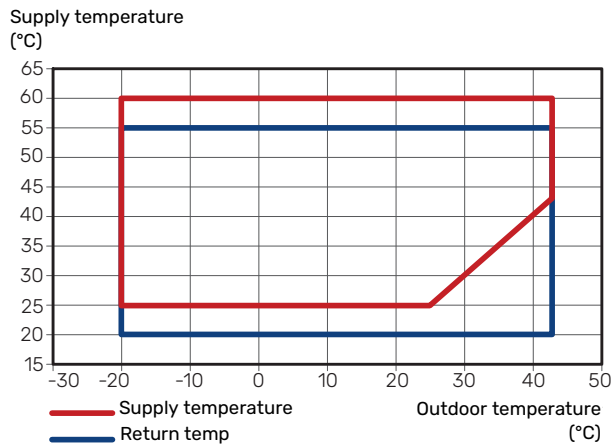

WORKING RANGE, COOLING

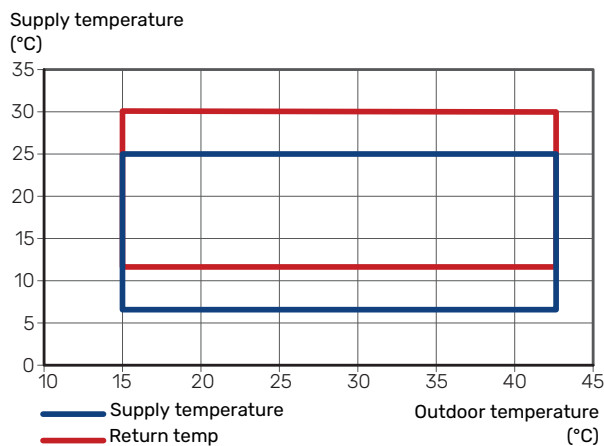

CAPACITY AND COP

Power and COP at different supply temperatures during continuous operation (excluding defrosting).

Power during heating operation

Maximum and minimum capacity during continuous operation.

AMS 20-6

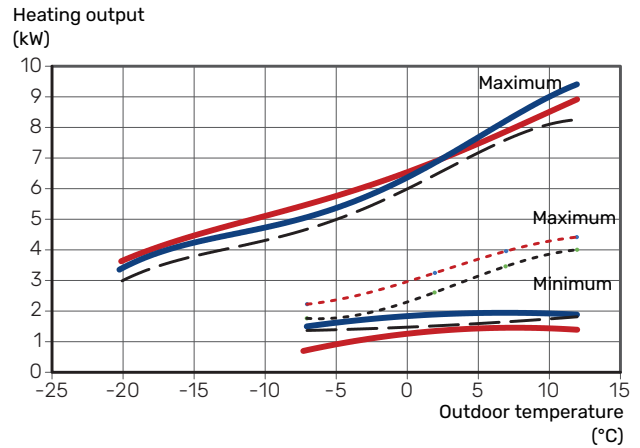

- Flow line temperature 35 °C
- Flow line temperature 45 °C
- Flow line temperature 55 °C
- - - Silent mode, supply temperature 35°C
- - - Silent mode, supply temperature 55°C

AMS 20-10

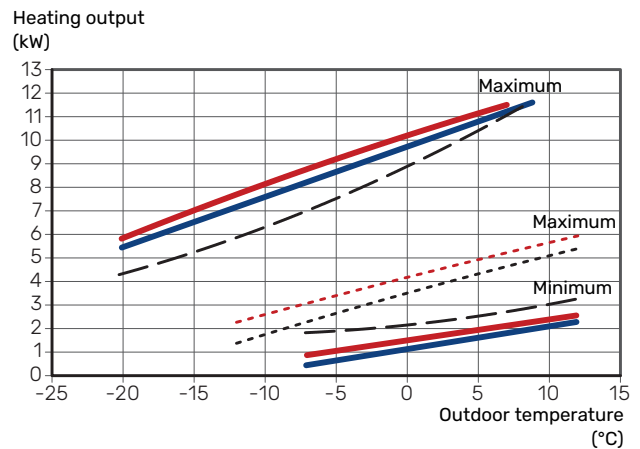

- Flow line temperature 35 °C
- Flow line temperature 45 °C
- Flow line temperature 55 °C
- - - Silent mode, supply temperature 35°C
- - - Silent mode, supply temperature 55°C

Power during cooling operation

Maximum and minimum capacity during continuous operation.

AMS 20-6

Cooling output (kW)

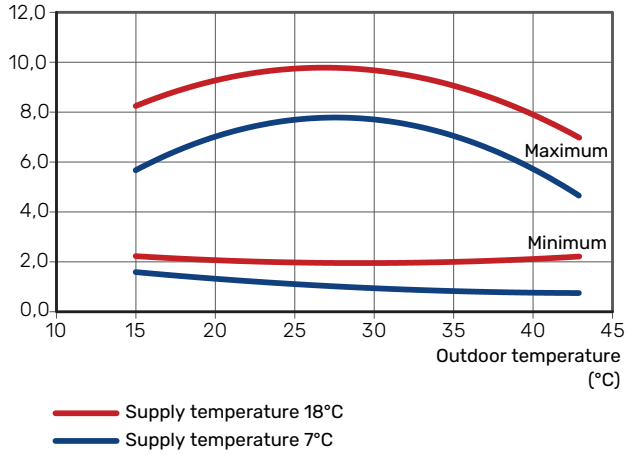

COP during heating operation

AMS 20-6

COP

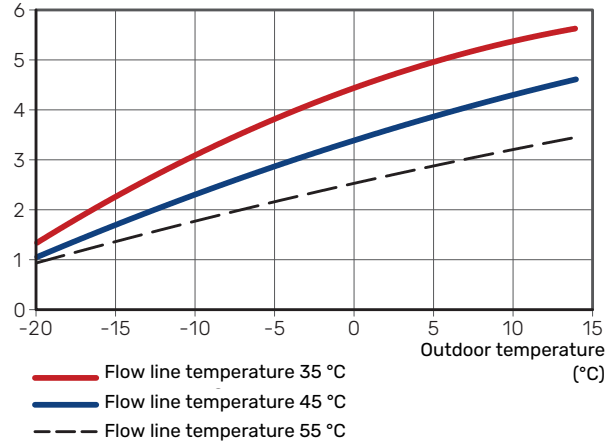

AMS 20-10

Cooling output (kW)

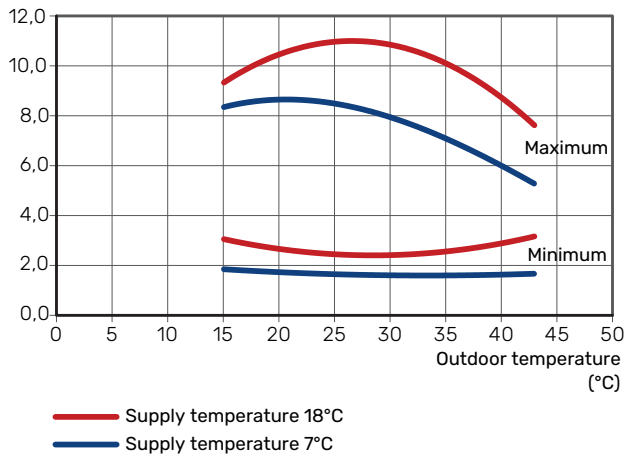

AMS 20-10

COP

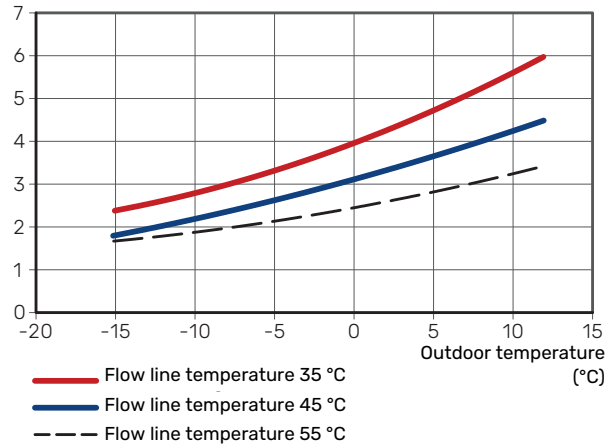

| Indoor unit SVM S332 | | 6 | 10 | 6 | 10 |
|---|-----------|---------------|---------------|------------------|------------------|
| Voltage | | 1 x 230 V | 1 x 230 V | 3 x 400 V | 3 x 400 V |
| Electrical data | | | | | |
| Max power, immersion heater (factory setting) | kW | 7 (7) | 7 (7) | 9 (9) | 9 (9) |
| Rated voltage | | 230 V ~ 50 Hz | 230 V ~ 50 Hz | 400 V 3N ~ 50 Hz | 400 V 3N ~ 50 Hz |
| Max operating current | A | 30.1 | 30.1 | 13.5 | 13.5 |
| Fuse | A | 32 | 32 | 16 | 16 |
| Output, heating medium pump (GP1) | W | 2 - 75 | 2 - 75 | 2 - 75 | 2 - 75 |
| Output, heating medium pump (GP1) | W | - | | | |
| Output, charge pump for hot water (GP8) | W | 2 - 45 | 2 - 45 | 2 - 45 | 2 - 45 |
| Enclosure class | | IPX1B | | | |
| Equipment Compliant with IEC 61000-3-12 | | | | | |
| For Connection Design Purposes, Compliant with IEC 61000-3-3 technical requirements | | | | | |
| WLAN | | | | | |
| 2.412 - 2.484 GHz max power | dbm | 11 | | | |
| Wireless units | | | | | |
| 2.405 - 2.480 GHz max power | dbm | 4 | | | |
| Heating medium circuit | | | | | |
| Min pressure in the heating medium circuit | MPa (bar) | 0.05 (0.5) | | | |
| Max pressure in the heating medium circuit | MPa (bar) | 0.3 (3) | | | |
| Max. pressure in brine system | MPa (bar) | 4 (40) | | | |
| Opening pressure, safety valve | MPa (bar) | 0.25 (2.5) | | | |
| Max. heating medium temperature | °C | 80 | | | |
| Pipe connections | | | | | |
| Heating medium ext Ø | mm | 22 | | | |
| Hot water connection ext Ø | mm | 22 | | | |
| Cold water connection ext Ø | mm | 22 | | | |
| Connection, gas pipe (Cu) Ø | mm | 12.7 (1/2") | 15.9 (5/8") | 12.7 (1/2") | 15.9 (5/8") |
| Connection, liquid pipe (Cu) Ø ¹ | mm | 6.35 (1/4") | | | |
| Hot water and heating section | | | | | |
| Volume storage tank hot water | litre | 140 | | | |
| Volume, total indoor | litre | 192 | | | |
| Volume buffer vessel | litre | 52 | | | |
| Min. permitted pressure in hot water heat exchanger | MPa (bar) | 0.01 (0.1) | | | |
| Max. permitted pressure in hot water heat exchanger | MPa (bar) | 1.0 (10) | | | |
| Capacity, hot water heating according to EN 16 147 | | | | | |
| Tap volume 40 °C (comfort mode Medium) ² | litre | 185 | | | |
| Dimensions and weight | | | | | |
| Width | mm | 600 | | | |
| Depth | mm | 620 | | | |
| Height ³ | mm | 1,800 | | | |
| Required ceiling height ⁴ | mm | 2,010 | | | |
| Weight | kg | 125 | 127 | 128 | 130 |
| Corrosion protection in the hot water heat exchanger | | Stainless | | | |
| Part no. | | | | | |
| Part no. | | 069 247 | 069 248 | 069 255 | 069 256 |

¹ If the length of the refrigerant pipes exceeds 15 metres, extra refrigerant must be added at 0.02 kg/m.

² This applies at a tap flow of 10 l/min.

³ Enclosed filterball valve (QZ2.1) is 120 mm high.

⁴ With feet removed, the height is approx. 1,940 mm.

| Outdoor module AMS 20 | | 6 | 10 |
|--|-------------------|----------------------------|----------------------------|
| Output data according to EN 14 511, partial load¹ | | | |
| Heating | -7 / 35 °C | 5.55 / 2.05 / 2.71 | 7.18 / 2.93 / 2.45 |
| Capacity / power input / COP (kW/kW/-) at nominal flow | 2 / 35 °C | 2.31 / 0.56 / 4.13 | 3.46 / 0.83 / 4.17 |
| Outdoor temp. / Supply temp. | 2 / 45 °C | 2.02 / 0.67 / 3.01 | 3.24 / 1.12 / 3.24 |
| | 7 / 35 °C | 2.64 / 0.49 / 5.42 | 4.00 / 0.75 / 5.33 |
| | 7 / 45 °C | 2.43 / 0.65 / 3.74 | 5.00 / 1.28 / 3.91 |
| Cooling | 35 / 7 °C | 5.32 / 1.94 / 2.74 | 7.07 / 2.40 / 2.95 |
| Capacity / power input / EER (kW/kW/-) at maximum flow | 35 / 18 °C | 7.55 / 2.11 / 3.58 | 10.79 / 3.00 / 3.60 |
| Outdoor temp. / Supply temp. | | | |
| SCOP according to EN 14 825 | | | |
| P _{designc} /SEER 7 / 12 / 35 °C | kW/- | 5.3 / 4.12 | 7.1 / 4.03 |
| P _{designc} /SEER 18 / 23 / 35 °C | kW/- | 7.6 / 6.08 | 10.8 / 5.17 |
| Nominal heat output (P _{designh}) average climate 35 °C / 55 °C (Europe) | kW | 5.20 / 5.60 | 6.30 / 6.45 |
| Nominal heat output (P _{designh}) cold climate 35 °C / 55 °C | kW | 5.80 / 5.70 | 6.50 / 6.20 |
| Nominal heat output (P _{designh}) warm climate 35 °C / 55 °C | kW | 5.57 / 5.48 | 6.80 / 6.60 |
| SCOP average climate, 35 °C / 55 °C (Europe) | | 5.08 / 3.56 | 4.59 / 3.36 |
| SCOP cold climate, 35 °C / 55 °C | | 4.10 / 3.05 | 3.95 / 2.94 |
| SCOP warm climate, 35 °C / 55 °C | | 6.70 / 4.53 | 6.59 / 4.49 |
| Energy rating, average climate² | | | |
| The product's room heating efficiency class 35 C / 55 C ³ | | A+++ / A++ | |
| The system's room heating efficiency class 35 C / 55 C ⁴ | | A+++ / A++ | |
| Electrical data | | | |
| Rated voltage | | 230 V ~ 50 Hz | |
| Max. operating current outdoor unit | A _{rms} | 15 | 16 |
| Max operating current, compressor | A _{rms} | 14 | 15 |
| Max. power, fan | W | 50 | 86 |
| Drain pan heating (integrated) | W | 110 | 100 |
| Fuse | A _{rms} | 16 | |
| Starting current | A _{rms} | 5 | |
| Enclosure class | | IP24 | |
| Refrigerant circuit | | | |
| Type of refrigerant | | R32 | |
| GWP refrigerant | | 675 | |
| Filling amount | kg | 1.3 | 1.84 |
| Type of compressor | | Twin Rotary | |
| CO ₂ equivalent | t | 0.88 | 1.24 |
| Cut-out value pressure switch HP (BP1) | MPa (bar) | - | 4.15 (41.5) |
| Cut-out value pressure switch LP (BP2) | MPa (bar) | - | 0.079 (0.79) |
| Max. length, refrigerant pipe, one way | m | 30 | 50 |
| Max height difference, when AMS 20 is placed higher than SVM S332 | m | 20 | 30 |
| Max height difference, when AMS 20 is placed lower than SVM S332 | m | 20 | 15 |
| Dimensions, refrigerant pipes, Gas pipe/Liquid pipe (Cu) Ø ⁵ | mm | 12.7 (1/2") / 6.35 (1/4") | 15.88 (5/8") / 6.35 (1/4") |
| Airflow | | | |
| Max airflow | m ³ /h | 2,530 | 3,000 |
| Working area | | | |
| Min./max. air temperature, heating | °C | -20 / 43 | |
| Min./max. air temperature, cooling | °C | 15 / 43 | |
| Defrosting system | | Reverse cycle | |
| Pipe connections | | | |
| Pipe connection option | | Right-hand side | |
| Pipe connections | | Flare | |
| Dimensions and weight | | | |
| Width | mm | 800 (+71 valve protection) | 880 (+88 valve protection) |
| Depth | mm | 290 | 340 (+ 110 with foot rail) |
| Height with stand | mm | 640 | 750 |
| Weight | kg | 46 | 60 |
| Miscellaneous | | | |
| Part no. | | 064 235 | 064 319 |
| EPREL | | 174 28 96 | 175 65 17 |

¹ Power statements including defrosting according to EN 14511 at heating medium supply corresponding to DT=5 K at 7 / 45.

² Reported efficiency for the system also takes the temperature regulator into account. If the system is supplemented with an external auxiliary boiler or solar heating, the total efficiency of the system must be recalculated.

- 3 Scale for the product's room heating efficiency class A+++ to D.
- 4 Scale for the system's room heating efficiency class A+++ to G.
- 5 If the length of the refrigerant pipes exceeds 15 metres, extra refrigerant must be added at 0.02 kg/m.

Energy labelling

INFORMATION SHEET

| Supplier | | NIBE | |
|---|-----|-----------------------|-------------------------|
| Model | | AMS 20-6 / SVM S332-6 | AMS 20-10 / SVM S332-10 |
| Temperature application | °C | 35 / 55 | 35 / 55 |
| Declared load profile for water heating | | XL | XL |
| Seasonal space heating energy efficiency class, average climate | | A+++ / A++ | A+++ / A++ |
| Water heating energy efficiency class, average climate | | A | A |
| Rated heat output (P_{designh}), average climate | kW | 5 / 6 | 6 / 6 |
| Annual energy consumption space heating, average climate | kWh | 2,116 / 3,250 | 2,834 / 3,961 |
| Annual energy consumption water heating, average climate | kWh | 1,558 | 1,627 |
| Seasonal space heating energy efficiency, average climate | % | 200 / 139 | 181 / 132 |
| Water heating energy efficiency, average climate | % | 107 | 103 |
| Sound power level L_{WA} indoors | dB | 35 | 35 |
| Rated heat output (P_{designh}), cold climate | kW | 6 / 6 | 7 / 6 |
| Rated heat output (P_{designh}), warm climate | kW | 6 / 5 | 7 / 7 |
| Annual energy consumption space heating, cold climate | kWh | 3,487 / 4,604 | 4,059 / 5,204 |
| Annual energy consumption water heating, cold climate | kWh | 1,869 | 2,030 |
| Annual energy consumption space heating, warm climate | kWh | 1,110 / 1,617 | 1,379 / 1,964 |
| Annual energy consumption water heating, warm climate | kWh | 1,300 | 1,336 |
| Seasonal space heating energy efficiency, cold climate | % | 161 / 119 | 155 / 114 |
| Water heating energy efficiency, cold climate | % | 90 | 82 |
| Seasonal space heating energy efficiency, warm climate | % | 265 / 178 | 260 / 177 |
| Water heating energy efficiency, warm climate | % | 129 | 125 |
| Sound power level L_{WA} outdoors | dB | 54 | 54 |

DATA FOR ENERGY EFFICIENCY OF THE PACKAGE

| Model | | AMS 20-6 / SVM S332-6 | AMS 20-10 / SVM S332-10 |
|--|----|-----------------------|-------------------------|
| Temperature application | °C | 35 / 55 | 35 / 55 |
| Controller, class | | VI | |
| Controller, contribution to efficiency | % | 4.0 | |
| Seasonal space heating energy efficiency of the package, average climate | % | 204 / 143 | 185 / 136 |
| Seasonal space heating energy efficiency class of the package, average climate | | A+++ / A++ | A+++ / A++ |
| Seasonal space heating energy efficiency of the package, cold climate | % | 165 / 123 | 159 / 118 |
| Seasonal space heating energy efficiency of the package, warm climate | % | 269 / 182 | 264 / 181 |

Reported efficiency for the system also takes the temperature regulator into account. If the system is supplemented with external additional heat or solar heating, the total efficiency of the system must be recalculated.

TECHNICAL DOCUMENTATION

| Model | | AMS 20-6 / SVM S332-6 | | | | | |
|---|---|-----------------------|-----|---|--------------------|-------|-------------------|
| Type of heat pump | <input checked="" type="checkbox"/> Air-water <input type="checkbox"/> Exhaust-water <input type="checkbox"/> Brine-water <input type="checkbox"/> Water-water | | | | | | |
| Low-temperature heat pump | <input type="checkbox"/> Yes <input checked="" type="checkbox"/> No | | | | | | |
| Integrated immersion heater for additional heat | <input checked="" type="checkbox"/> Yes <input type="checkbox"/> No | | | | | | |
| Heat pump combination heater | <input checked="" type="checkbox"/> Yes <input type="checkbox"/> No | | | | | | |
| Climate | <input checked="" type="checkbox"/> Average <input type="checkbox"/> Cold <input type="checkbox"/> Warm | | | | | | |
| Temperature application | <input checked="" type="checkbox"/> Medium (55°C) <input type="checkbox"/> Low (35°C) | | | | | | |
| Applied standards | EN 14825:2022, EN 16147:2017+A1:2022, EN 12102-1:2022 | | | | | | |
| Rated heat output | Prated | 5.6 | kW | Seasonal space heating energy efficiency | η_s | 139 | % |
| Declared capacity for space heating at part load and at outdoor temperature T_j | | | | Declared coefficient of performance for space heating at part load and at outdoor temperature T_j | | | |
| $T_j = -7\text{ °C}$ | Pdh | 5.0 | kW | $T_j = -7\text{ °C}$ | COPd | 1.95 | - |
| $T_j = +2\text{ °C}$ | Pdh | 2.9 | kW | $T_j = +2\text{ °C}$ | COPd | 3.51 | - |
| $T_j = +7\text{ °C}$ | Pdh | 1.9 | kW | $T_j = +7\text{ °C}$ | COPd | 4.99 | - |
| $T_j = +12\text{ °C}$ | Pdh | 1.7 | kW | $T_j = +12\text{ °C}$ | COPd | 6.33 | - |
| $T_j = \text{biv}$ | Pdh | 5.0 | kW | $T_j = \text{biv}$ | COPd | 1.95 | - |
| $T_j = \text{TOL}$ | Pdh | 4.6 | kW | $T_j = \text{TOL}$ | COPd | 1.75 | - |
| $T_j = -15\text{ °C}$ (if TOL < -20 °C) | Pdh | | kW | $T_j = -15\text{ °C}$ (if TOL < -20 °C) | COPd | | - |
| Bivalent temperature | T_{biv} | -7 | °C | Min. outdoor air temperature | TOL | -10 | °C |
| Cycling interval capacity | P _{cy} | | kW | Cycling interval efficiency | COP _{cy} | | - |
| Degradation coefficient | Cdh | 0.96 | - | Max supply temperature | WTOL | 58 | °C |
| <i>Power consumption in modes other than active mode</i> | | | | <i>Additional heat</i> | | | |
| Off mode | P _{OFF} | 0.007 | kW | Rated heat output | P _{sup} | 1.0 | kW |
| Thermostat-off mode | P _{TO} | 0.011 | kW | | | | |
| Standby mode | P _{SB} | 0.011 | kW | Type of energy input | Electric | | |
| Crankcase heater mode | P _{CK} | 0.000 | kW | | | | |
| <i>Other items</i> | | | | | | | |
| Capacity control | Variable | | | Rated airflow (air-water) | | 2,340 | m ³ /h |
| Sound power level, indoors/outdoors | L _{WA} | 35 / 54 | dB | Nominal heating medium flow | | | m ³ /h |
| Annual energy consumption | Q _{HE} | 3,250 | kWh | Brine flow brine-water or water-water heat pumps | | | m ³ /h |
| <i>For heat pump combination heater</i> | | | | | | | |
| Declared load profile for water heating | XL | | | Water heating energy efficiency | η_{wh} | 107 | % |
| Daily energy consumption | Q _{elec} | 7.357 | kWh | Daily fuel consumption | Q _{fuel} | | kWh |
| Annual energy consumption | AEC | 1,558 | kWh | Annual fuel consumption | AFC | | GJ |
| Contact information | NIBE Energy Systems - Box 14 - Hannabadsvägen 5 - 285 21 Markaryd - Sweden | | | | | | |

| Model | | AMS 20-10 / SVM S332-10 | | | | | | |
|---|---|-------------------------|-----|---|--------------------|-------|-------------------|--|
| Type of heat pump | <input checked="" type="checkbox"/> Air-water <input type="checkbox"/> Exhaust-water <input type="checkbox"/> Brine-water <input type="checkbox"/> Water-water | | | | | | | |
| Low-temperature heat pump | <input type="checkbox"/> Yes <input checked="" type="checkbox"/> No | | | | | | | |
| Integrated immersion heater for additional heat | <input checked="" type="checkbox"/> Yes <input type="checkbox"/> No | | | | | | | |
| Heat pump combination heater | <input checked="" type="checkbox"/> Yes <input type="checkbox"/> No | | | | | | | |
| Climate | <input checked="" type="checkbox"/> Average <input type="checkbox"/> Cold <input type="checkbox"/> Warm | | | | | | | |
| Temperature application | <input checked="" type="checkbox"/> Medium (55°C) <input type="checkbox"/> Low (35°C) | | | | | | | |
| Applied standards | EN 14825:2022, EN 16147:2017+A1:2022, EN 12102-1:2022 | | | | | | | |
| Rated heat output | Prated | 6.5 | kW | Seasonal space heating energy efficiency | η_s | 132 | % | |
| Declared capacity for space heating at part load and at outdoor temperature T_j | | | | Declared coefficient of performance for space heating at part load and at outdoor temperature T_j | | | | |
| $T_j = -7\text{ °C}$ | Pdh | 5.8 | kW | $T_j = -7\text{ °C}$ | COPd | 1.98 | - | |
| $T_j = +2\text{ °C}$ | Pdh | 3.5 | kW | $T_j = +2\text{ °C}$ | COPd | 3.17 | - | |
| $T_j = +7\text{ °C}$ | Pdh | 2.3 | kW | $T_j = +7\text{ °C}$ | COPd | 4.98 | - | |
| $T_j = +12\text{ °C}$ | Pdh | 2.2 | kW | $T_j = +12\text{ °C}$ | COPd | 5.50 | - | |
| $T_j = \text{biv}$ | Pdh | 5.8 | kW | $T_j = \text{biv}$ | COPd | 1.98 | - | |
| $T_j = \text{TOL}$ | Pdh | 5.8 | kW | $T_j = \text{TOL}$ | COPd | 1.69 | - | |
| $T_j = -15\text{ °C}$ (if TOL < -20 °C) | Pdh | | kW | $T_j = -15\text{ °C}$ (if TOL < -20 °C) | COPd | | - | |
| | | | | | | | | |
| Bivalent temperature | T_{biv} | -7 | °C | Min. outdoor air temperature | TOL | -10 | °C | |
| Cycling interval capacity | P _{cy} | | kW | Cycling interval efficiency | COP _{cy} | | - | |
| Degradation coefficient | Cdh | 0.98 | - | Max supply temperature | WTOL | 60 | °C | |
| <i>Power consumption in modes other than active mode</i> | | | | <i>Additional heat</i> | | | | |
| Off mode | P _{OFF} | 0.003 | kW | Rated heat output | P _{sup} | 0.7 | kW | |
| Thermostat-off mode | P _{TO} | 0.008 | kW | | | | | |
| Standby mode | P _{SB} | 0.008 | kW | Type of energy input | Electric | | | |
| Crankcase heater mode | P _{CK} | 0.000 | kW | | | | | |
| | | | | | | | | |
| <i>Other items</i> | | | | | | | | |
| Capacity control | Variable | | | Rated airflow (air-water) | | 3,000 | m ³ /h | |
| Sound power level, indoors/outdoors | L _{WA} | 35 / 54 | dB | Nominal heating medium flow | | | m ³ /h | |
| Annual energy consumption | Q _{HE} | 3,961 | kWh | Brine flow brine-water or water-water heat pumps | | | m ³ /h | |
| | | | | | | | | |
| <i>For heat pump combination heater</i> | | | | | | | | |
| Declared load profile for water heating | XL | | | Water heating energy efficiency | η_{wh} | 103 | % | |
| Daily energy consumption | Q _{elec} | 7,720 | kWh | Daily fuel consumption | Q _{fuel} | | kWh | |
| Annual energy consumption | AEC | 1,627 | kWh | Annual fuel consumption | AFC | | GJ | |
| Contact information | NIBE Energy Systems – Box 14 – Hannabadsvägen 5 – 285 21 Markaryd – Sweden | | | | | | | |

Electrical circuit diagram

SVM S332, 1X230 V

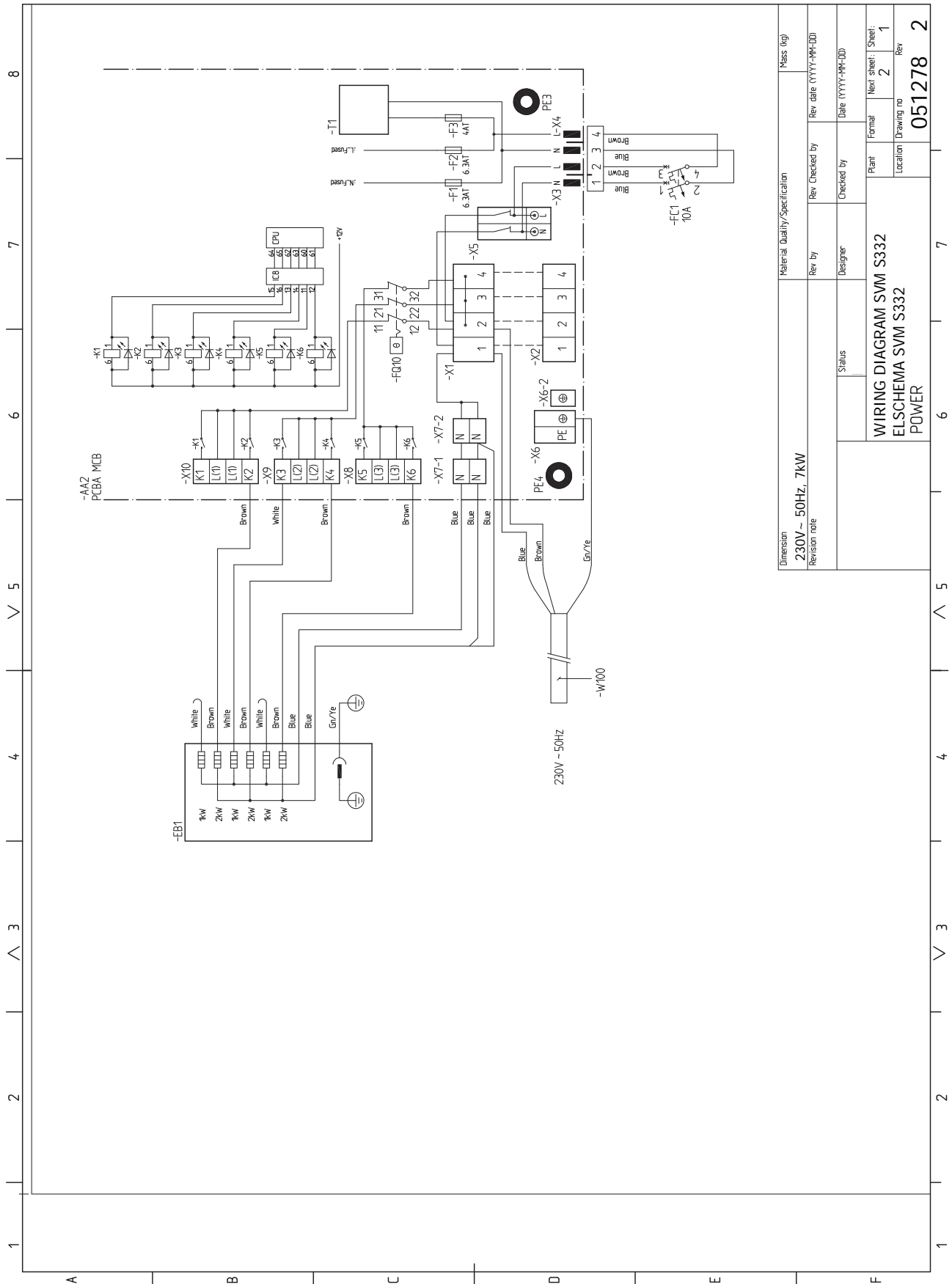

| | | | |
|--------------------------------|----------------|------------|-----------------------|
| Material Quality/Specification | | Mass (kg) | |
| Dimension | 230V-50Hz, 7kW | Rev by | Rev date (YYYY-MM-DD) |
| Revision note | | Designer | Date (YYYY-MM-DD) |
| Status | | Plant | Next sheet / Sheet |
| WIRING DIAGRAM SVM S332 | | Location | 051278 |
| ELSCHEMA SVM S332 | | Drawing no | 2 |
| POWER | | Rev | 1 |

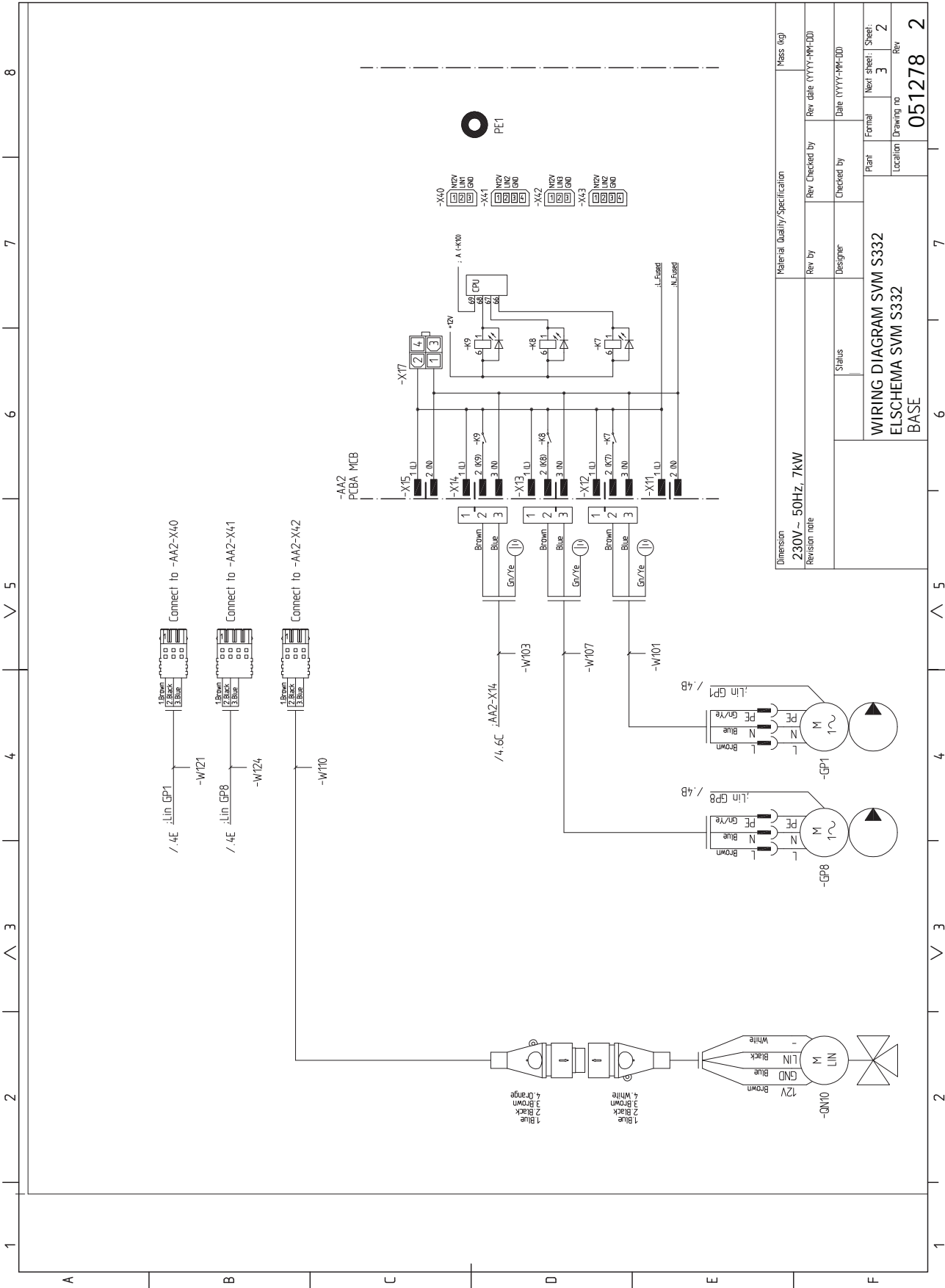

| | | | | | |
|------------------|--|--------------------------------|-----------------|------------------------|---|
| Dimension | | Material Quality/Specification | | Mass (kg) | |
| 230V ~ 50Hz, 7kW | | | | | |
| Revision note | | Rev. by | Rev. Checked by | Rev. date (YYYY-MM-DD) | |
| | | Designer | Checked by | Date (YYYY-MM-DD) | |
| | | Status | | | |
| | | Plant | Format | Next sheet / Sheet | |
| | | Location | | 3 / 2 | |
| | | | | Drawing no | |
| | | | | 051278 | |
| | | | | Rev | 2 |

WIRING DIAGRAM SVM S332
ELSCHEMA SVM S332
BASE

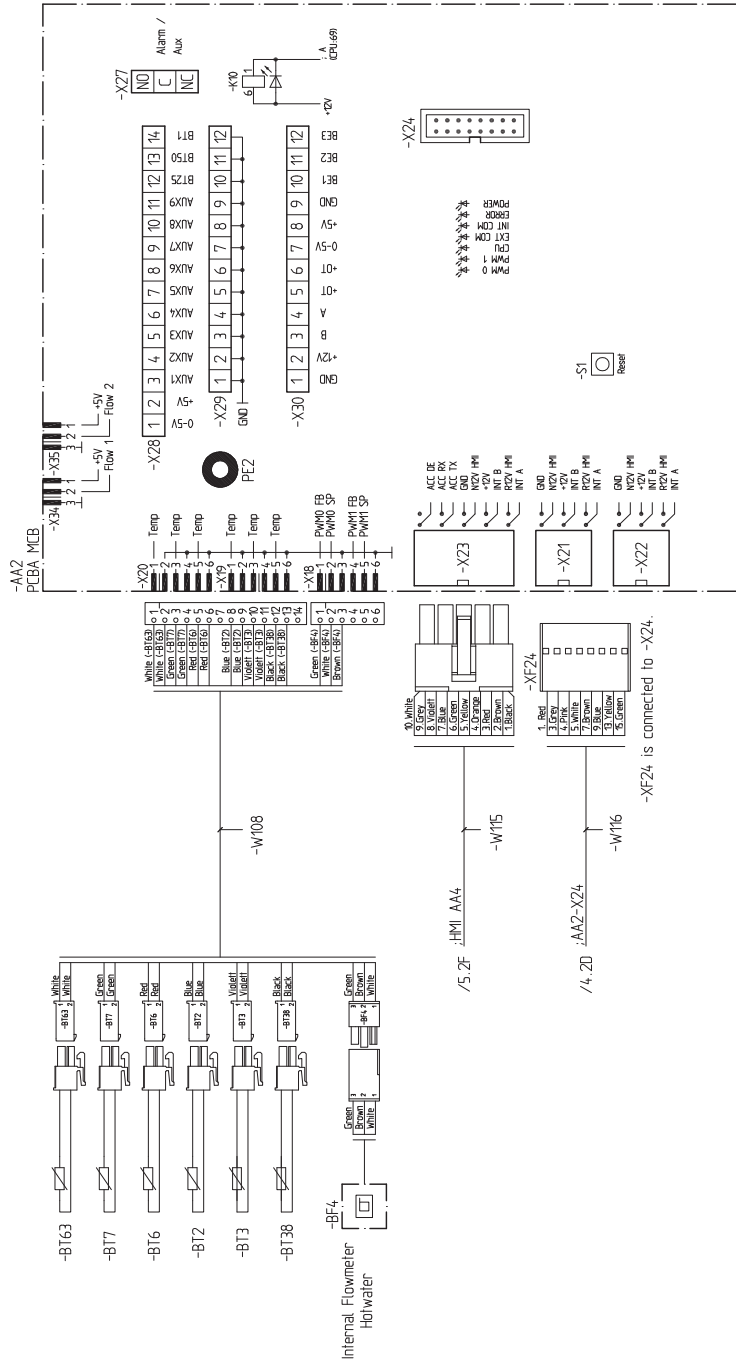

| | | | | | |
|------------------|--|--------------------------------|----------------|-----------------------|--------------------|
| Dimension | | Material Quality/Specification | | Mass (kg) | |
| 230V ~ 50Hz, 7kW | | | | | |
| Revision note | | Rev by | Rev Checked by | Rev date (YYYY-MM-DD) | |
| | | Designer | Checked by | Date (YYYY-MM-DD) | |
| | | Status | | Plant | Next sheet / Sheet |
| | | | | Location | 4 / 3 |
| | | | | Drawing no | 051278 |
| | | | | Rev | 2 |

**WIRING DIAGRAM SVM S332
ELSCHEMA SVM S332
INPUT**

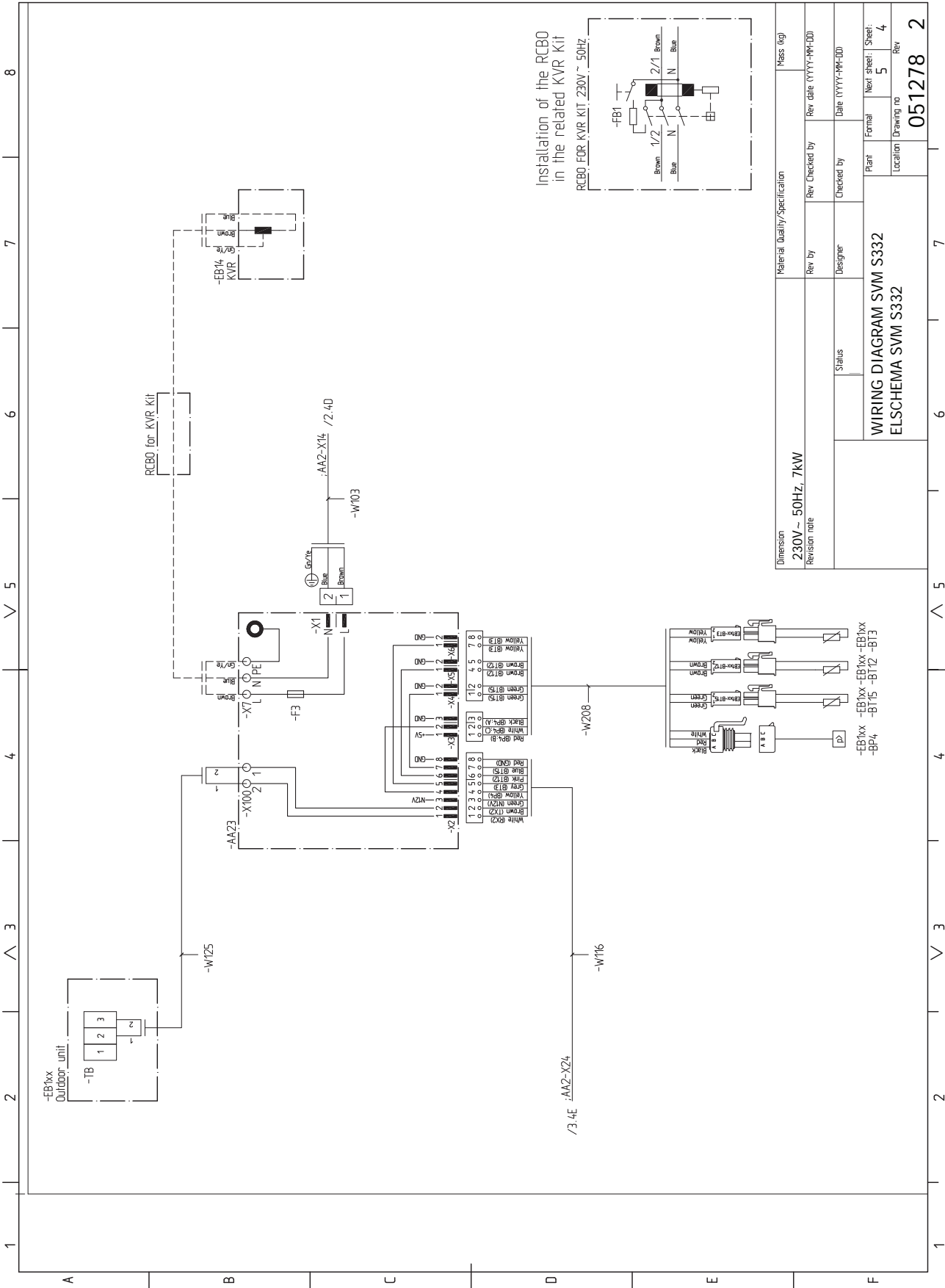

Installation of the RCBO
in the related KVR kit

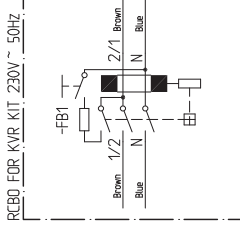

| | | |
|--|------------------------|----------------------|
| Material Quality/Specification | | Mass (kg) |
| Dimension | 230V ~ 50Hz, 7KW | |
| Revision note | | |
| Rev. Checked by | Rev. date (YYYY-MM-DD) | |
| Designer | Checked by | Date (YYYY-MM-DD) |
| Status | | |
| Plant | Format | Next sheet: Sheet: 4 |
| Location | Drawing no | Rev |
| WIRING DIAGRAM SVM S332 ELSCHEMA SVM S332 | | 051278 2 |

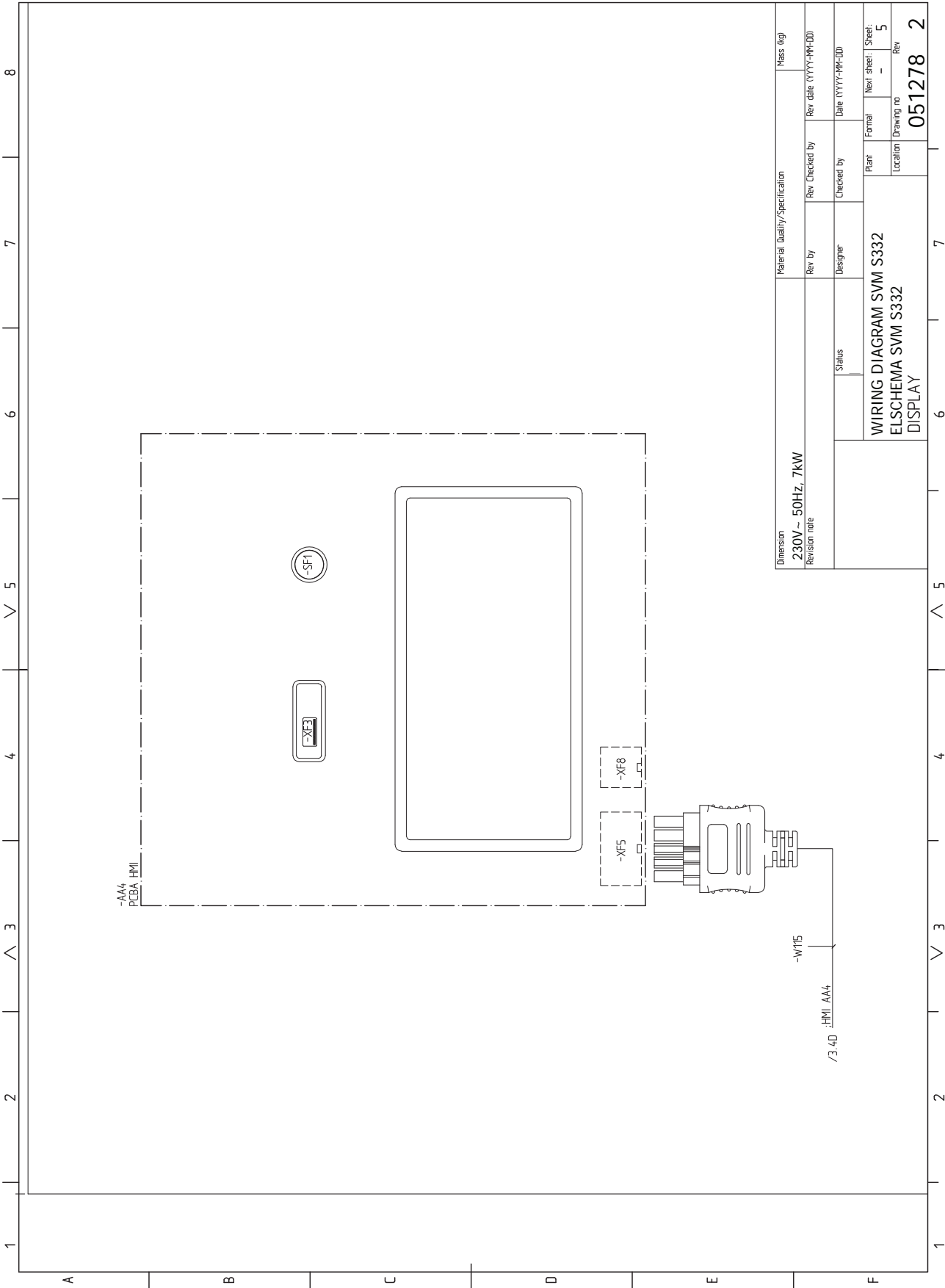

| | | | |
|-------------------------|--------------------------------|----------------|-----------------------|
| Dimension | Material Quality/Specification | | Mass (kg) |
| 230V ~ 50Hz, 7kW | Rev by | Rev Checked by | Rev date (YYYY-MM-DD) |
| Revision note | Designer | Checked by | Date (YYYY-MM-DD) |
| | Status | | |
| WIRING DIAGRAM SVM S332 | | Plant | Formal |
| ELSCHEMA SVM S332 | | Location | Next sheet: Sheet: 5 |
| DISPLAY | | Drawing no | Rev |
| | | 051278 | 2 |

1 2 3 4 5 6 7 8

A B C D E F

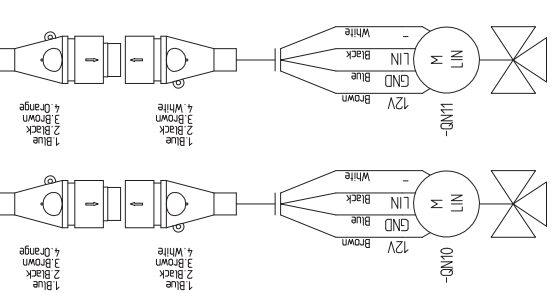
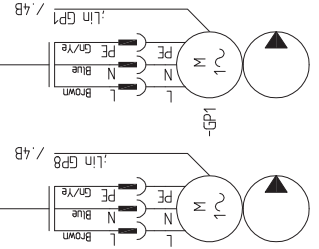
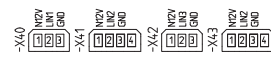
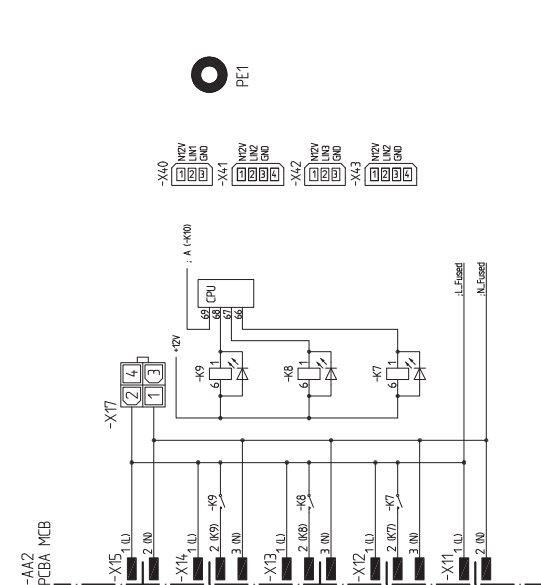
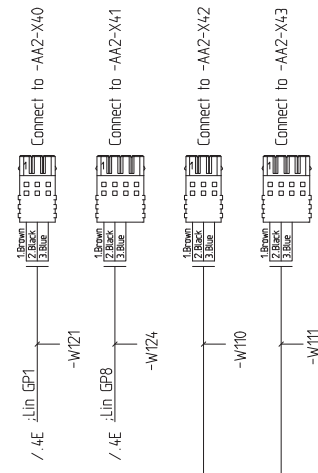

| | | | | | |
|-------------------------|--|--------------------------------|----------------|-----------------------|-------|
| Dimension | | Material Quality/Specification | | Mass (kg) | |
| 400V 3N~ 50Hz, 9KW | | | | | |
| Revision note | | Rev by | Rev Checked by | Rev date (YYYY-MM-DD) | |
| | | Designer | Checked by | Date (YYYY-MM-DD) | |
| | | Status | | | |
| WIRING DIAGRAM SVM S332 | | Plant | Format | Next sheet | Sheet |
| ELSCHEMA SVM S332 | | Location | | 3 | 2 |
| BASE | | Drawing no | | 051294 | 3 |
| | | Rev | | | |

1 2 3 4 5 6 7 8

A B C D E F

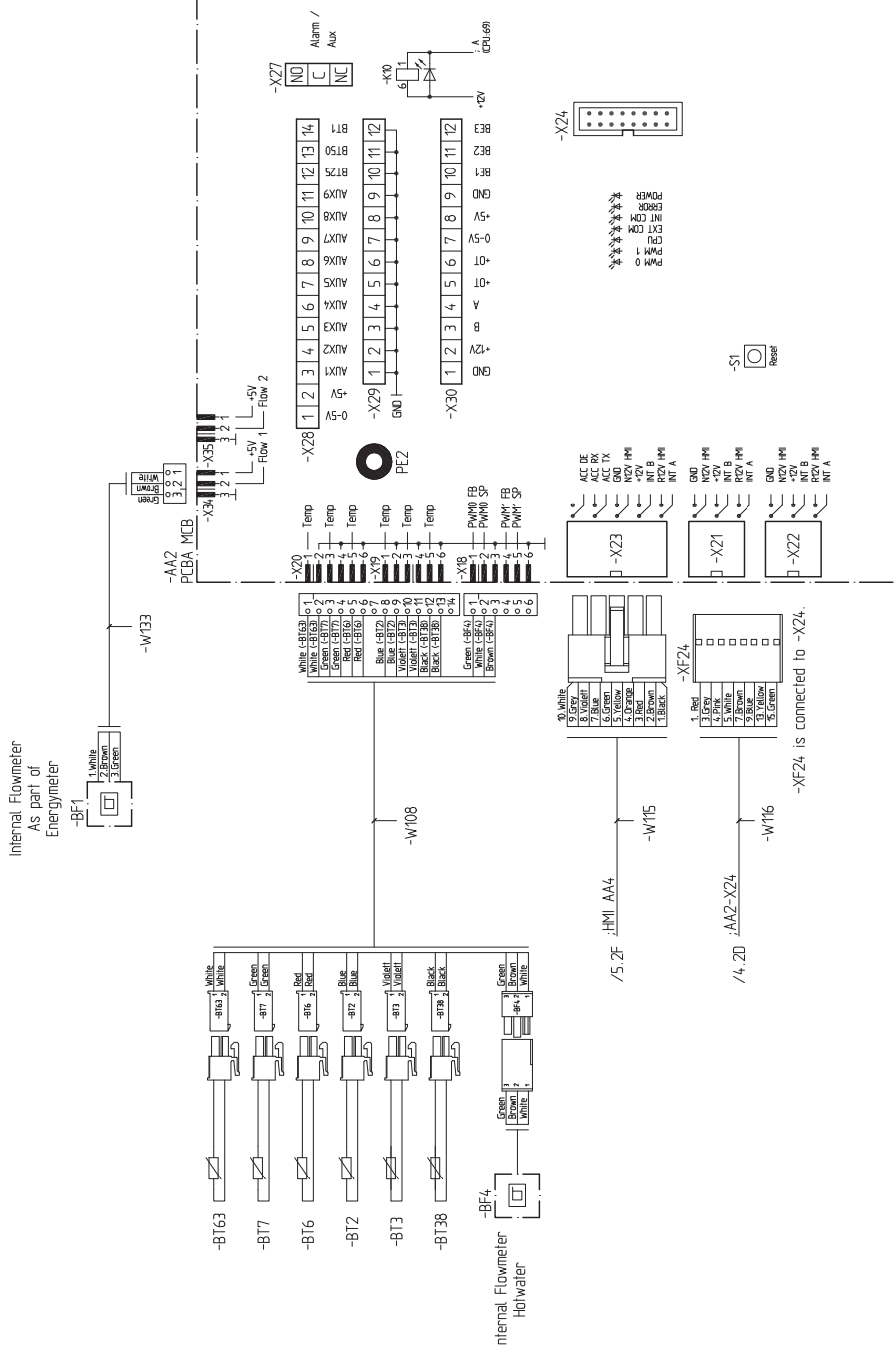

| | | | |
|---|-------------------|-----------|-----------------------|
| Material Quality/Specification | | Mass (kg) | |
| Dimension | 400V 3N-50HZ, 9KW | Rev by | Rev date (YYYY-MM-DD) |
| Revision note | | Designer | Date (YYYY-MM-DD) |
| Status | | Plant | Next sheet / Sheet |
| WIRING DIAGRAM SVM S332 ELSCHEMA SVM S332 INPUT | | Location | Drawing no |
| | | 051294 | 3 |

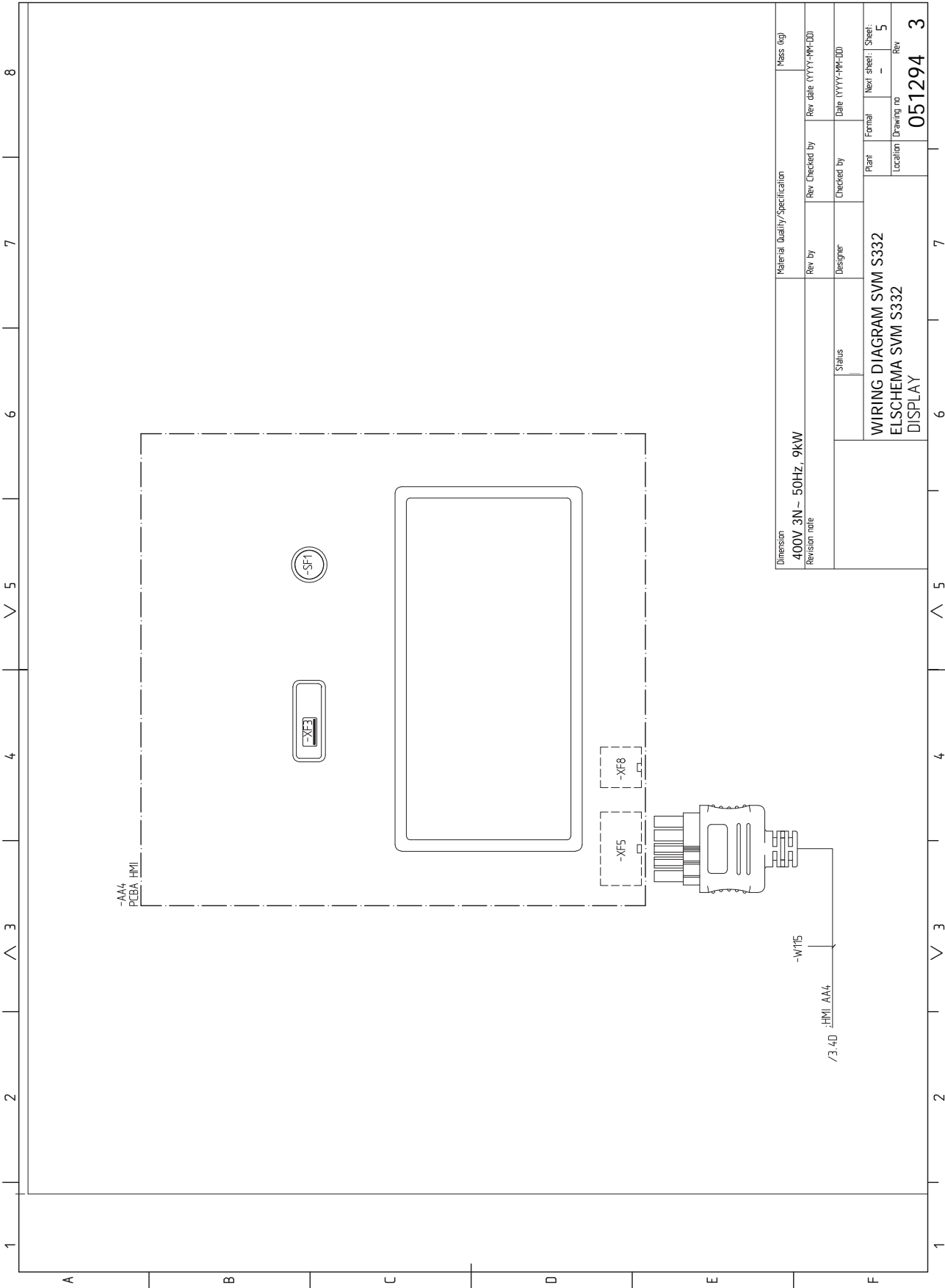

| | | | | |
|-------------------------|--|--------------------------------|----------------|-----------------------|
| Dimension | | Material Quality/Specification | | Mass (kg) |
| 400V 3N~ 50HZ, 9KW | | | | |
| Revision note | | Rev by | Rev Checked by | Rev date (YYYY-MM-DD) |
| | | Designer | Checked by | Date (YYYY-MM-DD) |
| | | Status | | |
| WIRING DIAGRAM SVM S332 | | Plant | Formal | Next sheet / Sheet |
| ELSCHEMA SVM S332 | | Location | Drawing no | Rev |
| DISPLAY | | | 051294 | 3 |

AMS 20-6

POWER SOURCE
1 PHASE
220-240V 50Hz
220V 60Hz

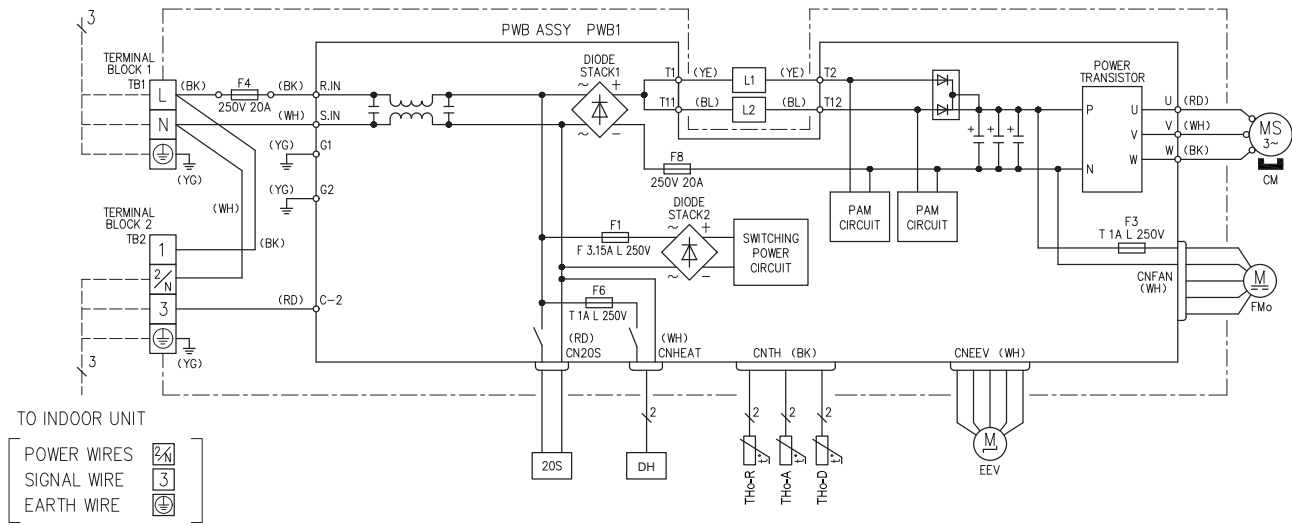

AMS 20-10

230V ~ 50Hz

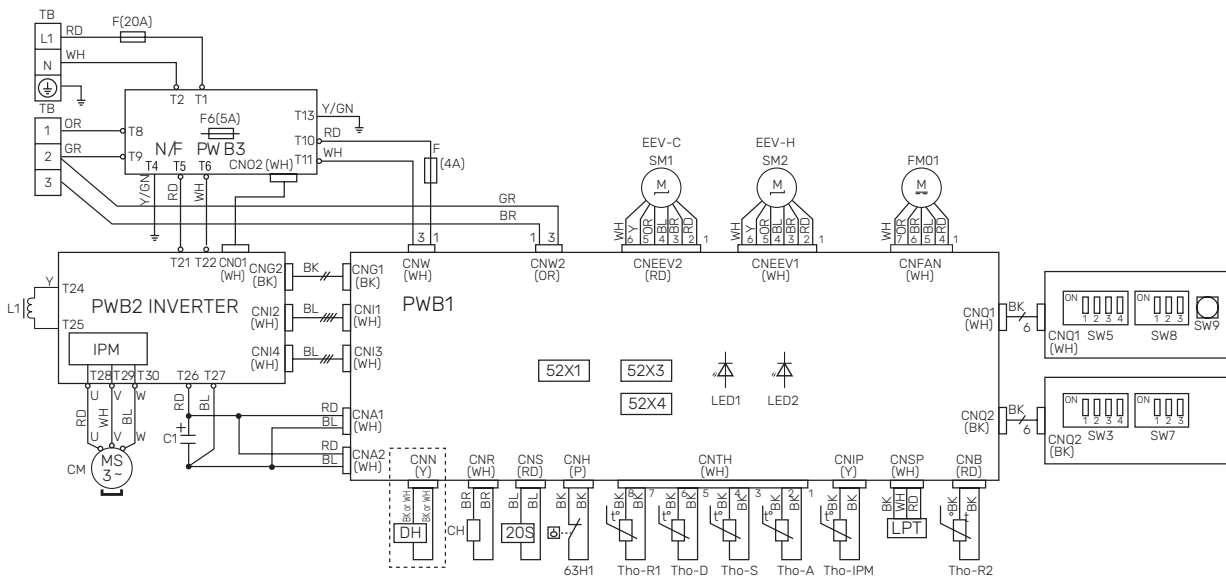

| Designation | Description |
|--------------|--|
| 20S | Reversing valve |
| 63H1 | High pressure switch |
| C1 | Capacitor |
| CH | Compressor heater |
| CM | Compressor |
| CnA-Z | Terminal block |
| CT | Current sensor |
| DH | Drip tray heater |
| F | Fuse |
| FM01 | Fan |
| L/L1 | Induction coil |
| LED1 | Indication lamp (red) |
| LED2 | Indication lamp (green) |
| LPT | Low-pressure sensor |
| EEV | Expansion valve |
| EEV-H | Expansion valve, heating |
| EEV-C | Expansion valve, cooling |
| TB | Terminal block, supply voltage and communication |
| BT28 (Tho-A) | Ambient sensor |
| Tho-D | Hot gas sensor |
| Tho-R | Evaporator sensor, out |
| Tho-R2 | Evaporator sensor, in |
| Tho-S | Suction gas sensor |

Item register

- A**
- Accessories, 78
- Air/water heat pump, 34
- Alarm, 74
- Alarm list, 76
- Assembly, 7
- C**
- Climate system, 25
- Climate systems and zones, 48
 - Control - Introduction, 48
- Cold and hot water, 26
 - Connecting cold and hot water, 26
- Commissioning, 41
- Commissioning and adjusting, 39
 - Commissioning, 41
 - Commissioning without outdoor unit, 42
 - Compressor heater, 39
 - Filling and venting, 40
 - Preparations, 39
 - Setting the cooling/heating curve, 42
 - Start guide, 41
- Commissioning without outdoor unit, 42
- Communication, 34
- Communication connection, 34
- Component placement
 - Sensor placement, 20
- Compressor heater, 39
- Condensation, 11
- Connecting accessories, 35
- Connecting current sensors, 33
- Connecting external operating voltage for the control system, 30
- Connecting hot water circulation, 27
- Connecting sensors, 32
- Connecting the climate system, 25
- Connections, 30
- Control, 45
 - Control - Introduction, 45
- Control - Introduction, 45
- Control - Menus
 - Menu 1 - Indoor climate, 49
 - Menu 2 - Hot water, 53
 - Menu 3 - Info, 54
 - Menu 4 - My system, 55
 - Menu 5 - Connection, 59
 - Menu 6 - Scheduling, 60
 - Menu 7 - Service, 61
- Cooling, 26
- D**
- Data for sensor in SVM S332-10, 71
- Data for sensor in SVM S332-6, 71
- Delivery and handling, 7
 - Assembly, 7
 - Condensation, 11
 - Handling panels, 15
 - Installation area, 7, 10
 - Removing the covers, 13
 - Supplied components, 12
 - Transport, 7, 9
- Dimensions, 80-81
- Dimensions, indoor unit, 80
- Disruption to comfort
 - Info menu, 74
- Disturbances in comfort, 74
 - Alarm, 74
 - Alarm list, 76
 - Manage alarm, 74
 - Troubleshooting, 74
- Docking alternatives
 - Two or more climate systems, 26
- Draining the climate system, 70
- Draining the hot water heat exchanger, 69
- E**
- Electrical addition - maximum output, 38
 - Power steps of the immersion heater, 38
- Electrical circuit diagram, 92, 102
- Electrical connection, 28
 - General, 28
- Electrical connections, 28
 - Air/water heat pump, 34
 - Communication, 34
 - Communication connection, 34
 - Connecting accessories, 35
 - Connecting external operating voltage for the control system, 30
 - Connecting sensors, 32
- Connections, 30
 - Electrical addition - maximum output, 38
 - External connection options, 35
 - External connections, 32
 - External energy meter, 32
 - External heating cable (KVR 10), 34
 - External supply temperature sensor, 32
 - Load monitor, 33
 - Outdoor sensor, 32
 - Power connection, 30-31
 - Room sensor, 32
 - Settings, 38
 - Single phase compressor, 38
 - Supply voltage, 30
 - Tariff control, 31
- Energy labelling, 89
 - Data for energy efficiency of the package, 89
 - Information sheet, 89
 - Technical documentation, 90
- External connection options, 35
 - Possible selection for AUX inputs, 36
 - Possible selection for AUX output (potential free variable relay), 37
- External connections, 32
- External energy meter, 32
- External heating cable (KVR 10), 34
- External supply temperature sensor, 32
- F**
- Filling, 40
- Filling and venting, 40
 - Filling, 40
 - Filling the hot water heat exchanger, 40
 - Venting the climate system, 40
- Filling the hot water heat exchanger, 40
- H**
- Handling panels, 15
- Heating medium side, 25

Help menu, 46

I

Important information, 4

Inspection of the installation, 5

Marking, 4

Safety information, 4

Symbols, 4

Indoor module's design

Component locations, 16

Info menu, 74

Inspection of the installation, 5

Installation alternative, 26

Connecting hot water circulation, 27

Water heater with immersion heater, 27

Installation area, 7, 10

L

List of components SVM S332 (EZ101), 19

Load monitor, 33

M

Manage alarm, 74

Marking, 4

Menu 1 - Indoor climate, 49

Menu 2 - Hot water, 53

Menu 3 - Info, 54

Menu 4 - My system, 55

Menu 5 - Connection, 59

Menu 6 - Scheduling, 60

Menu 7 - Service, 61

Modbus TCP/IP, 73

myUplink, 44

N

Navigation

Help menu, 46

O

Outdoor sensor, 32

P

Pipe and ventilation connections

Climate system, 25

Connecting the climate system, 25

Pipe connections, 21

Boiler and radiator volumes, 21

Cold and hot water

Connecting cold and hot water, 26

Cooling, 26

General pipe connections, 21

Heating medium side, 25

Installation alternative, 26

Refrigerant pipe, 24

Symbol key, 22

System diagram, 22

Use without heat pump, 25

Possible selection for AUX inputs, 36

Possible selection for AUX output (potential free variable relay), 37

Power connection, 30–31

Preparations, 39

Pump speed, 42

R

Refrigerant pipe, 24

Removing the covers, 13

Room sensor, 32

S

Safety information, 4

Inspection of the installation, 5

Marking, 4

Serial number, 4

Symbols, 4

Sensor placement, 20

Serial number, 4

Service, 69

Data for sensor in SVM S332-10, 71

Data for sensor in SVM S332-6, 71

Service actions, 69

Service actions, 69

Draining the climate system, 70

Modbus TCP/IP, 73

Standby mode, 69

Temperature sensor data, 70

USB service outlet, 72

Service measures

Draining the hot water heat exchanger, 69

Settings, 38

Emergency mode, 38

Setting the cooling/heating curve, 42

Single phase compressor, 38

Sound levels, 83

Standby mode, 38, 69

Start guide, 41

Start-up and inspection

Pump speed, 42

Supplied components, 12

Supply voltage, 30

Symbol key, 22

Symbols, 4

System diagram, 22

T

Tariff control, 31

Technical data, 80

Dimensions, 80–81

Dimensions, indoor unit, 80

Electrical circuit diagram, 92, 102

Energy labelling, 89

Sound pressure levels, 83

Technical Data, 84

Technical Data, 84

Temperature sensor data, 70

The heat pump design

List of components SVM S332 (EZ101), 19

The outdoor unit's design

Component placement, 18

The split system's design, 16

Transport, 7, 9

Troubleshooting, 74

U

USB service outlet, 72

Use without heat pump, 25

V

Venting the climate system, 40

Contact information

AUSTRIA

KNV Energietechnik GmbH
Gahberggasse 11, 4861 Schörfling
Tel: +43 (0)7662 8963-0
mail@knv.at
knv.at

FINLAND

NIBE Energy Systems Oy
Juurakkotie 3, 01510 Vantaa
Tel: +358 (0)9 274 6970
info@nibe.fi
nibe.fi

GREAT BRITAIN

NIBE Energy Systems Ltd
3C Broom Business Park,
Bridge Way, S41 9QG Chesterfield
Tel: +44 (0)330 311 2201
info@nibe.co.uk
nibe.co.uk

POLAND

NIBE-BIAWAR Sp. z o.o.
Al. Jana Pawla II 57, 15-703 Białystok
Tel: +48 (0)85 66 28 490
biawar.com.pl

CZECH REPUBLIC

Družstevní závody Dražice - strojírna
s.r.o.
Dražice 69, 29471 Benátky n. Jiz.
Tel: +420 326 373 801
nibe@nibe.cz
nibe.cz

FRANCE

NIBE Energy Systems France SAS
Zone industrielle RD 28
Rue du Pou du Ciel, 01600 Reyrieux
Tél: 04 74 00 92 92
info@nibe.fr
nibe.fr

NETHERLANDS

NIBE Energietechnik B.V.
Energieweg 31, 4906 CG Oosterhout
Tel: +31 (0)168 47 77 22
info@nibenl.nl
nibenl.nl

SWEDEN

NIBE Energy Systems
Box 14
Hannabadsvägen 5, 285 21 Markaryd
Tel: +46 (0)433-27 30 00
info@nibe.se
nibe.se

DENMARK

Vølund Varmeteknik A/S
Industrivej Nord 7B, 7400 Herning
Tel: +45 97 17 20 33
info@volundvt.dk
volundvt.dk

GERMANY

NIBE Systemtechnik GmbH
Am Reiherpfahl 3, 29223 Celle
Tel: +49 (0)5141 75 46 -0
info@nibe.de
nibe.de

NORWAY

ABK-Qviller AS
Brobekkeveien 80, 0582 Oslo
Tel: (+47) 23 17 05 20
post@abkqviller.no
nibe.no

SWITZERLAND

NIBE Wärmetechnik c/o ait Schweiz AG
Industriepark, CH-6246 Altishofen
Tel. +41 (0)58 252 21 00
info@nibe.ch
nibe.ch

For countries not mentioned in this list, contact NIBE Sweden or check nibe.eu for more information.

NIBE Energy Systems
Hannabadsvägen 5
Box 14
SE-285 21 Markaryd
info@nibe.se
nibe.eu

IHB EN 2547-3 631467

This is a publication from NIBE Energy Systems. All product illustrations, facts and data are based on the available information at the time of the publication's approval.

NIBE Energy Systems makes reservations for any factual or printing errors in this publication.

©2026 NIBE ENERGY SYSTEMS

