

Installer manual

NIBE

Air/water heat pump

NIBE S2125



IHB EN 2525-1
831880

Table of Contents

1	Important information _____	4	8	Service _____	37
	Safety information _____	4		Service actions _____	37
	Symbols _____	4			
	Marking _____	4	9	Disturbances in comfort _____	38
	Serial number _____	4		Troubleshooting _____	38
	Inspection of the installation _____	5		Alarm list _____	40
	System solutions _____	5	10	Accessories _____	43
2	Delivery and handling _____	6	11	Technical data _____	44
	Transport _____	6		Dimensions _____	44
	Assembly _____	7		Sound levels _____	46
	Condensation _____	8		Technical specifications _____	47
	Supplied components _____	9		Energy labelling _____	54
	Removing panels _____	10		Electrical circuit diagram _____	64
	Installation of automatic gas separator _____	11			
3	The heat pump design _____	14		Item register _____	80
	General _____	14		Contact information _____	83
	Distribution boxes _____	21			
4	Pipe connections _____	23			
	General _____	23			
	Symbol key _____	23			
	Pipe coupling heating medium circuit _____	24			
5	Electrical connections _____	25			
	General _____	25			
	Accessibility, electrical connection _____	25			
	Connections _____	26			
6	Commissioning and adjusting _____	29			
	Preparations _____	29			
	Filling and venting _____	29			
	Readjusting, heating medium side _____	29			
	Commissioning _____	29			
	Adjustment, charge flow _____	30			
	Charge pump _____	30			
	Pressure drop, heating medium side _____	30			
7	Control _____	31			
	General _____	31			
	Master control _____	31			
	Control conditions _____	32			
	Activating S2125 _____	33			

Important information

Safety information

This manual describes installation and service procedures for implementation by specialists.

The manual must be left with the customer.

For the latest version of the product's documentation, see nibe.eu.



CAUTION!

Also read the enclosed Safety Manual before starting the installation.

Symbols

Explanation of symbols that may be present in this manual.



CAUTION!

This symbol indicates danger to person or machine.



NOTE!

This symbol indicates important information about what you should consider when installing or servicing the installation.



TIP!

This symbol indicates tips on how to facilitate using the product.

Marking

Explanation of symbols that may be present on the product's label(s).



Fire hazard!



Dangerous voltage.



Read the User Manual.



Read the Installer Manual.



Disconnect the voltage supply before starting work.

Serial number

The serial number on S2125 can be found on the rear cover and at the bottom on the side on the type plate (PZ1).

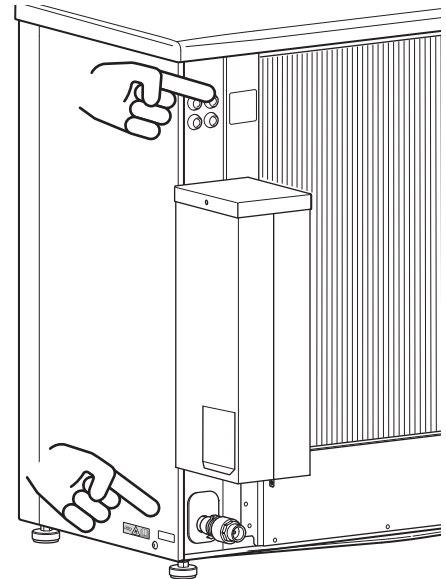

NOTE!

You need the product's (14 digit) serial number for servicing and support.

Inspection of the installation

Current regulations require the heating installation to undergo an installation inspection before it is commissioned. The inspection must be carried out by a suitably qualified person. In addition, fill in the page for information regarding the installation data in the User Manual.

✓	Description	Notes	Signature	Date
	Heating medium (page 23)			
	Automatic gas separator installed			
	System flushed			
	System vented			
	Particle filter			
	Shut-off valve			
	Charge flow set			
	Electricity (page 25)			
	Fuses property			
	Safety breaker			
	Earth circuit-breaker			
	Heating cable type/effect			
	Fuse size, heating cable (F3)			
	Communication cable connected			
	S2125 addressed (only when cascade connection)			
	Cooling permitted			
	Connections			
	Main voltage			
	Phase voltage			
	Miscellaneous			
	Condensation water pipe			
	Insulation for condensation water pipe, thickness (unless KVR 11 is used)			



CAUTION!

Check the connections, main voltage and phase voltage before powering up the heat pump, to prevent damage to the heat pump electronics.

System solutions

Go to [CompatibilityAWHP](#) or scan the QR code below.



This provides information about possible combinations with S2125. (Some products are not sold in all markets).

Delivery and handling

Transport

S2125 should be transported and stored vertically in a dry place.



CAUTION!

Ensure that the heat pump cannot fall over during transport.

Check that S2125 has not been damaged during transport.

LIFT FROM THE STREET TO THE SET UP LOCATION

If the surface allows, the easiest method is to use a pallet truck to move the heat pump to the installation area.



CAUTION!

The centre of gravity is offset to one side (see print on the packaging).

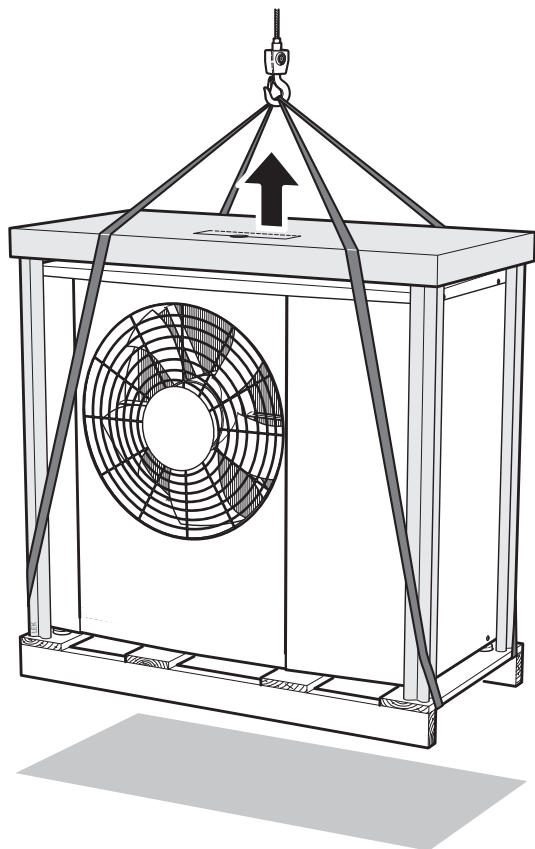

If the heat pump needs to be transported across soft ground, such as a lawn, we recommend using a crane truck that can lift it to the installation location. When the heat pump is lifted with a crane, the packaging must be intact

If a crane truck cannot be used, the heat pump can be transported on an extended sack truck. The heat pump must be taken hold of from its heaviest side and two people are required to lift it.

LIFT FROM THE PALLET TO FINAL POSITIONING

Before lifting remove the packaging and the securing strap to the pallet.

Place lifting straps around each foot. Four people are recommended for lifting from the pallet to the foundation, one for each lifting strap.

SCRAPPING

When scrapping, remove the heat pump in reverse order. In this case, lift by the base plate rather than the pallet!

Assembly

- Place the heat pump in a suitable location outdoors to prevent any risk of the refrigerant flowing in through ventilation openings, doors or similar openings in the event of a leak. It must also not constitute a hazard to people or property in any other way.
- If the heat pump is placed in a location where any refrigerant leak could accumulate, for example below ground level (in a dip or low-lying recess), the installation must satisfy the same requirements that apply for gas detection and the ventilation of engineering rooms. Requirements regarding sources of ignition must be applied where appropriate.
- Place S2125 outdoors on a solid level base that can take the weight, preferably a concrete foundation. If concrete slabs are used they must rest on asphalt or shingle.
- S2125 should not be positioned next to noise sensitive walls, for example, next to a bedroom.
- Also ensure that the placement does not inconvenience the neighbours.
- S2125 must not be placed so that recirculation of the outdoor air is possible. Recirculation entails reduced power and impaired efficiency.
- The evaporator must be sheltered from direct wind / , which negatively affects the defrosting function. Place S2125 protected from wind / against the evaporator.
- A small amount of water may drip from the drainage hole under S2125. Make sure that the water can run away by selecting a suitable material underneath S2125 (see section "Condensation").
- If the product has a plug covering the condensation drain connection (XL40), remove it.

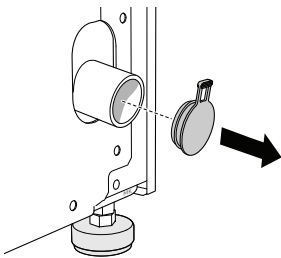

If there is a risk of snow slip from roof, a protective roof or cover must be erected to protect the heat pump, pipes and wiring.

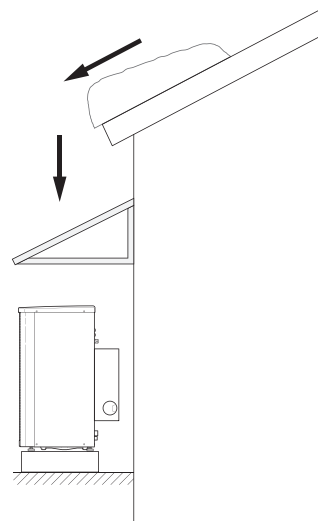

INSTALLATION AREA

Leave a free space of at least 350 mm between S2125 and the house wall, but not more than 500 mm in windy locations.

Leave a free space of 1,000 mm in front of, and 1,000 mm above, the product.

Approx. 600 mm free space is required on the right-hand side to allow the side panel to be removed.

The lower edge of the evaporator must not be lower than the level of the average local snow depth, or at least 300 mm above ground level. The base should be at least 70 mm tall.

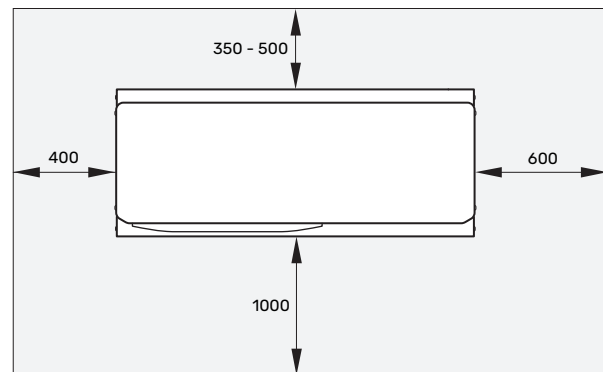

Condensation

The condensate drain pan collects and leads away the condensation water.



CAUTION!

It is important to the heat pump function that condensation water is led away and that the drain for the condensation water run off is not positioned so that it can cause damage to the house.

Pipe with heating cable (KVR), for draining the condensate drip tray, is not included. To guarantee this function, the accessory KVR should be used.

- The condensation water (up to 50 litres/24 hrs) that collects in the trough should be routed away by a pipe to an appropriate drain, it is recommended that the shortest outdoor stretch possible is used.
- The section of the pipe that can be affected by frost must be heated by the heating cable to prevent freezing.
- Route the pipe downward from the heat pump.
- The outlet of the condensation water pipe must be at frost free depth.
- Use a water trap for installations where air circulation may occur in the condensation water pipe.
- The insulation must seal against the bottom of the condensation water trough.

DRAINAGE OF CONDENSATION



NOTE!

If none of the following recommended alternatives is used, good drainage of condensation must be provided.

Stone caisson

If the house has a cellar the stone caisson must be positioned so that condensation water does not affect the house. Otherwise, the stone caisson can be positioned directly below the heat pump.

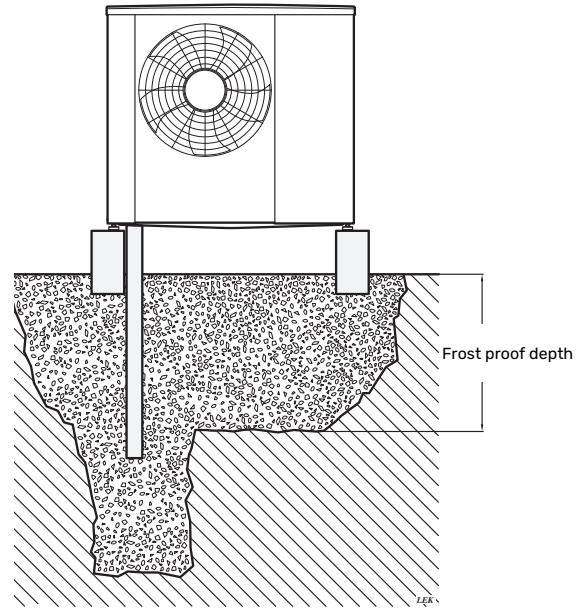

Gutter drainage

Route the pipe sloping down from the heat pump. The condensation water pipe must have a water seal to prevent air circulation in the pipe.

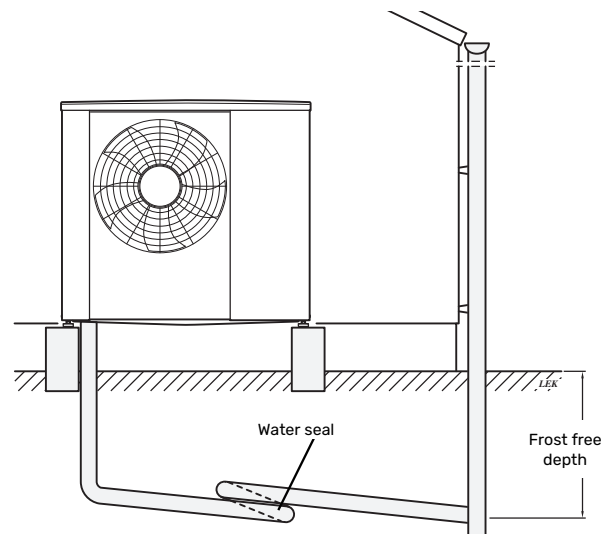

Supplied components

S2125-8, -12

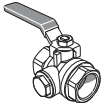

1 x filterball (G1") (QZ2)

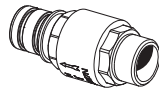

1 x non-return valve (RM1.2)

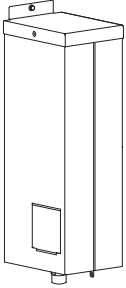

1 x automatic gas separator (QZ3)

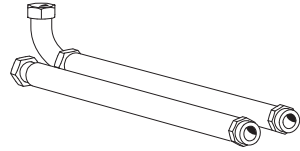

1 x flexible pipe with bend (WN2)
1 x flexible pipe (WN3)
(Dimensions, flexible pipes DN25, G1")
4 x gaskets

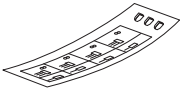

2 x labels for external control voltage of the control system

S2125-16, -20

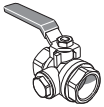

1 x filterball (G1¼") (QZ2)

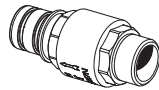

1 x non-return valve (RM1.2)

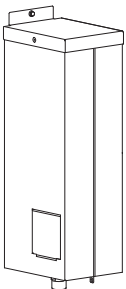

1 x automatic gas separator (QZ3)

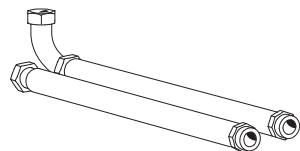

1 x flexible pipe with bend (WN2)
1 x flexible pipe (WN3)
(Dimensions, flexible pipes DN25, G1¼")
4 x gaskets

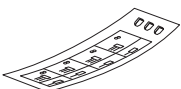

2 x labels for external control voltage of the control system

Removing panels

Undo the screws, lift off the top panel and the top insulation¹.

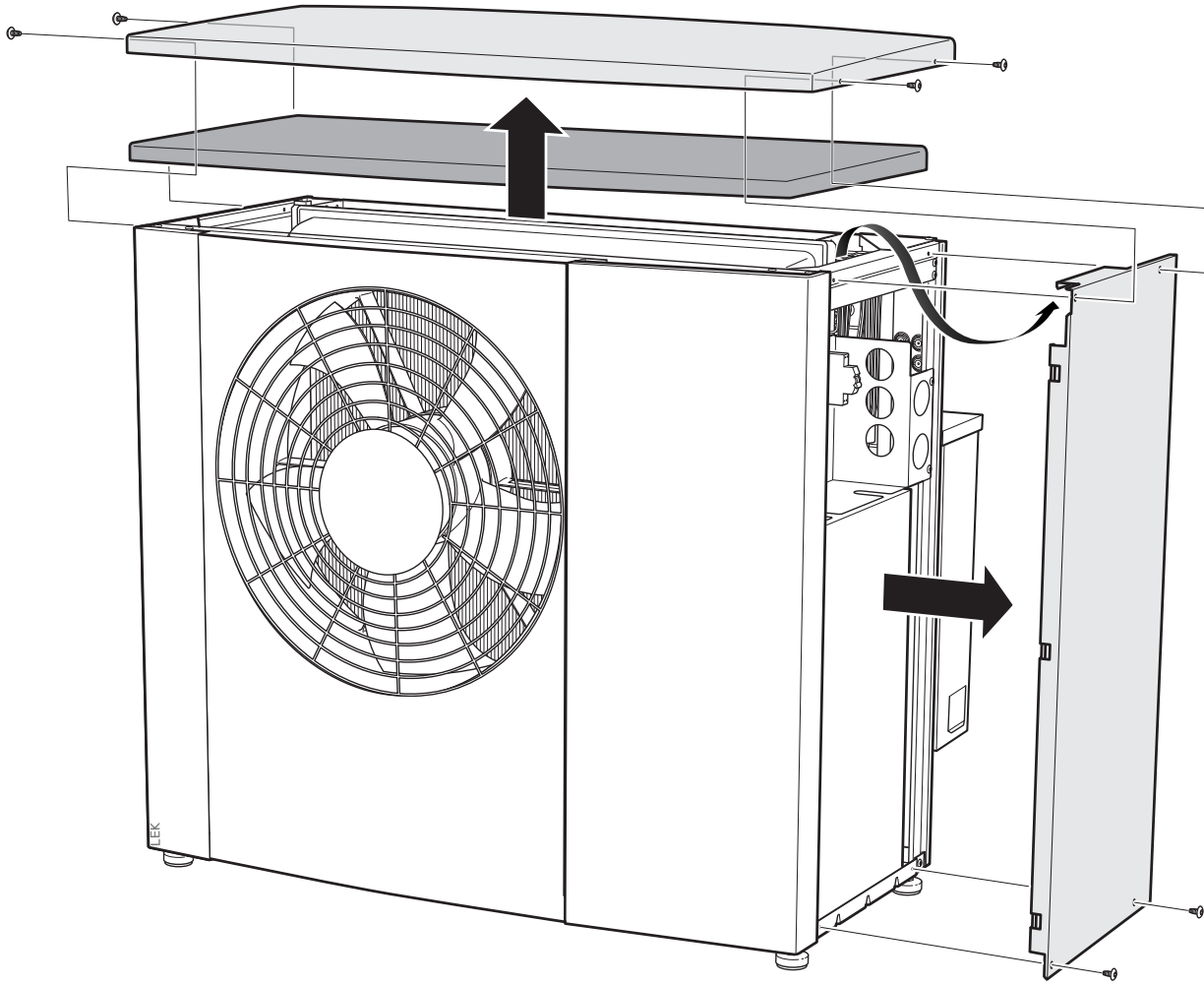

¹ Top insulation is only used for S2125-8/-12.

Installation of automatic gas separator

The automatic gas separator and the safety valve should always be installed as instructed below.

1. Check that all O-rings are present and that they are undamaged. Lubricate them with soapy water or similar to make installation easier.

Press the gas separator into place. Fit the clip. Twist the clip to ensure that it fastens properly.

Place the bracket in position, parallel with the outer edge. Secure the bracket with a screw. Use a socket wrench, size 10 mm.

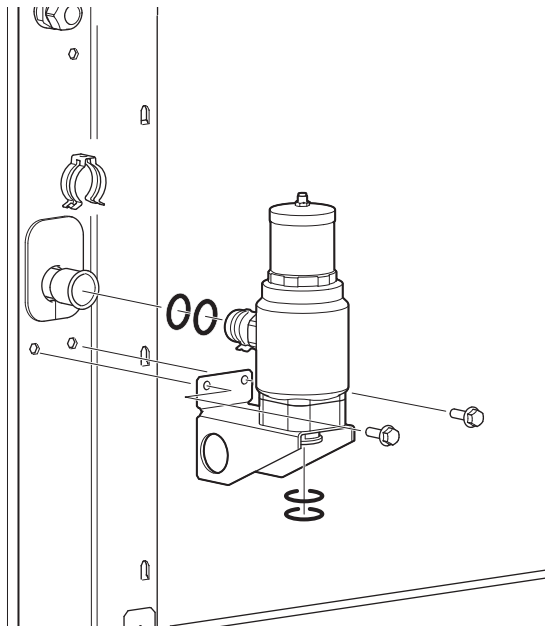

2. Assemble the parts of the safety valve. Ensure that the arrow for the outlet is pointing down.

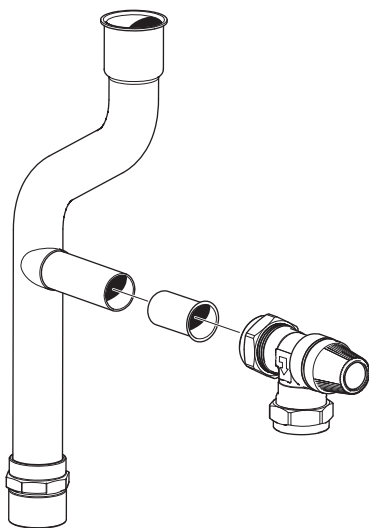

3. Then fit the safety valve with the associated pipes. The safety valve must be at an angle of 45°. Fit the clip. Twist the clip to ensure that it fastens properly.

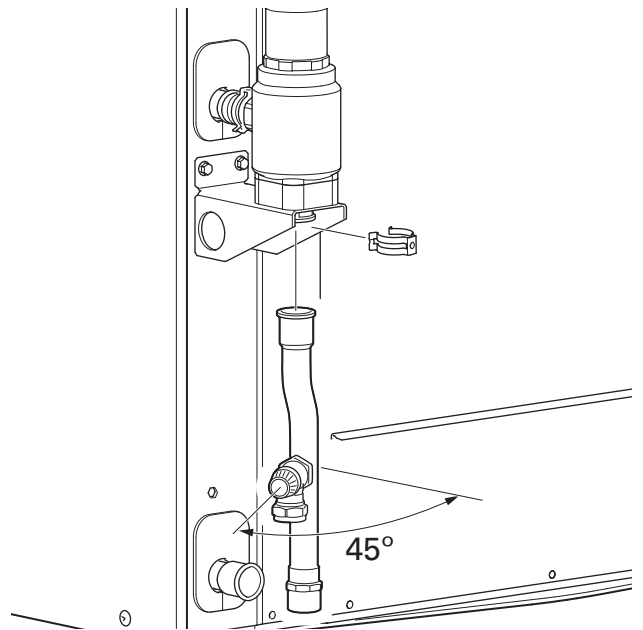

4. Install the non-return valve. Fit the clip. Twist the clip to ensure that it fastens properly.

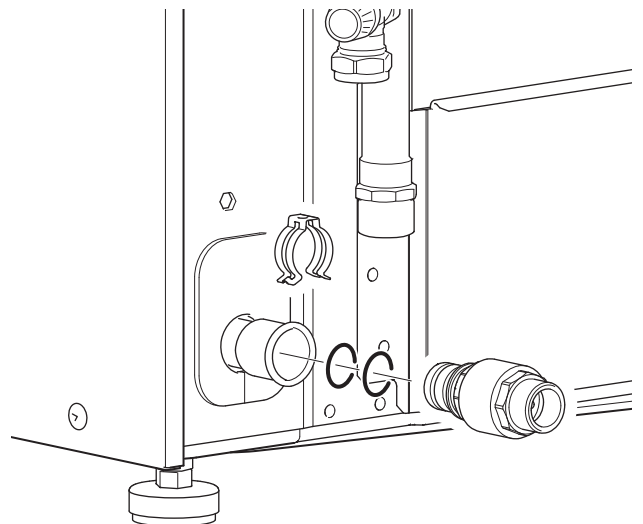

5. Install the right-hand side of the metal box. The lug in the insulation must go into the round hole in the bracket.

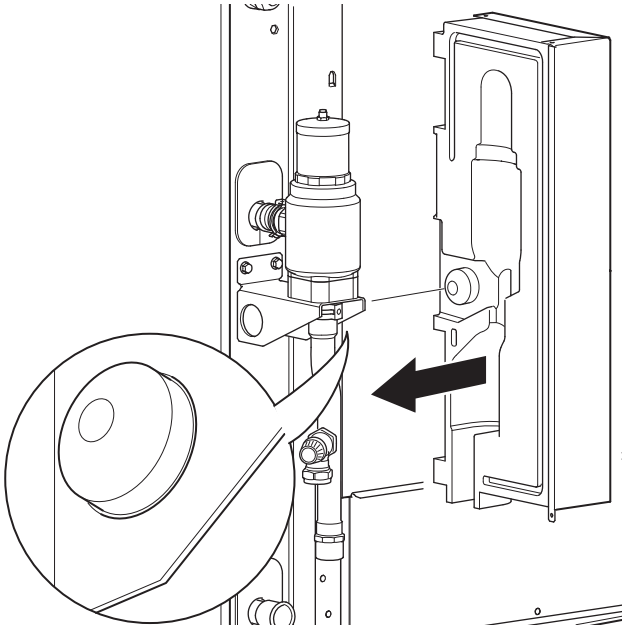

7. Check that both halves of the gas separator are properly in place, parallel with the edge of the heat pump.

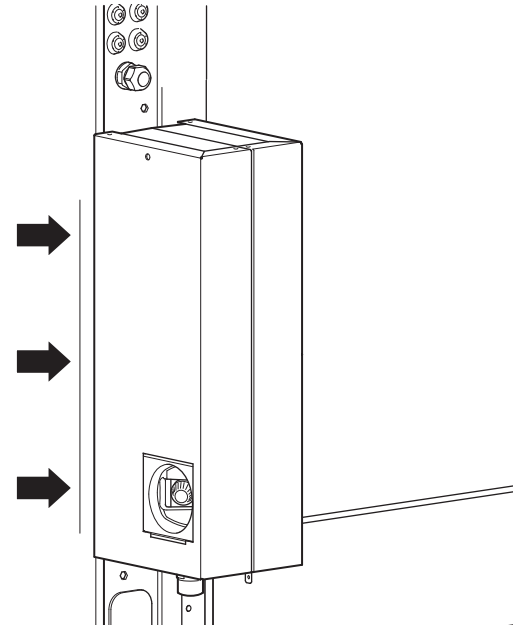

6. Fit the left-hand side in the same way.

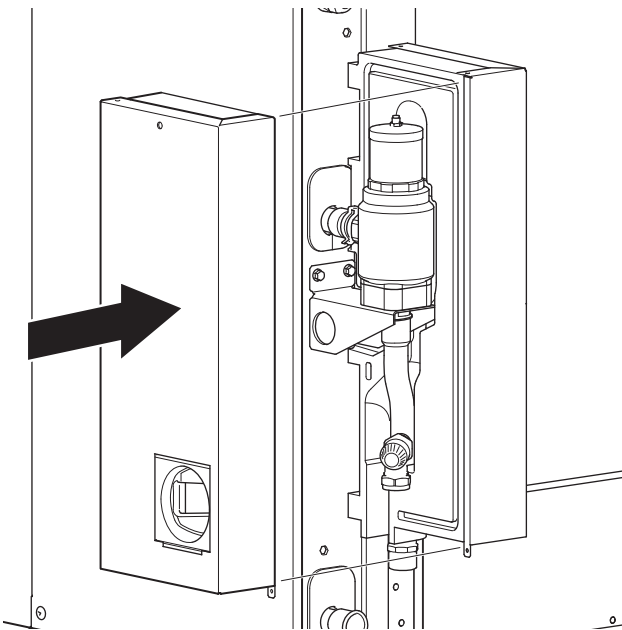

8. Fit the cover. Secure with three screws. Two screws in the lid, on the right and left-hand sides, and one screw in the bottom.

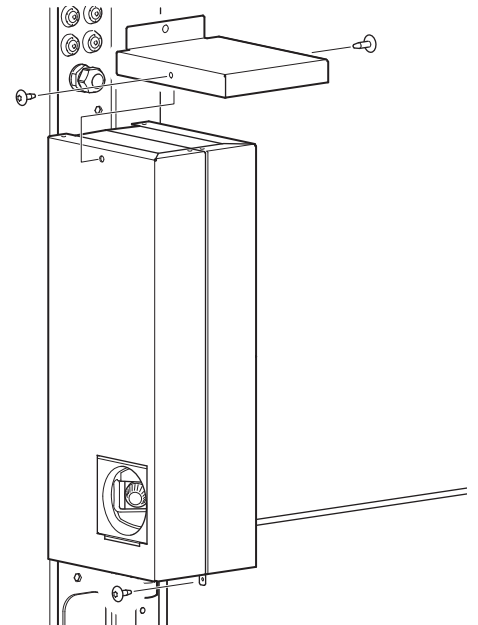

- Secure the gas separator to the heat pump using two screws, one at the top and one at the bottom.

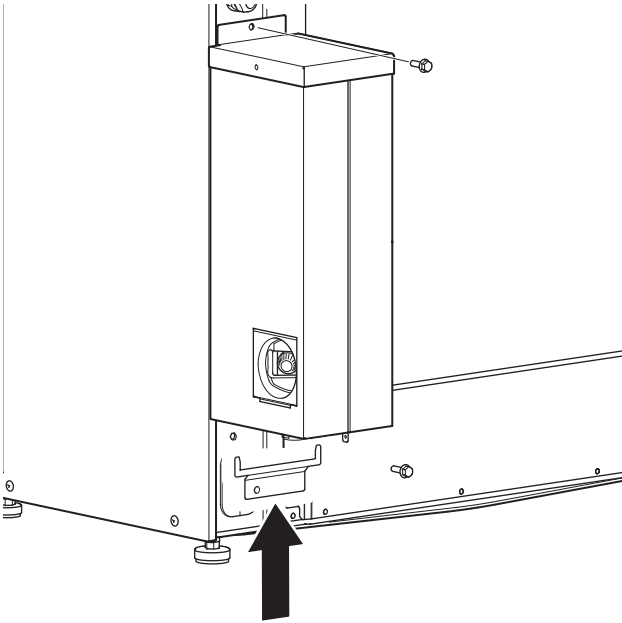

- Install the lid that conceals the safety valve.

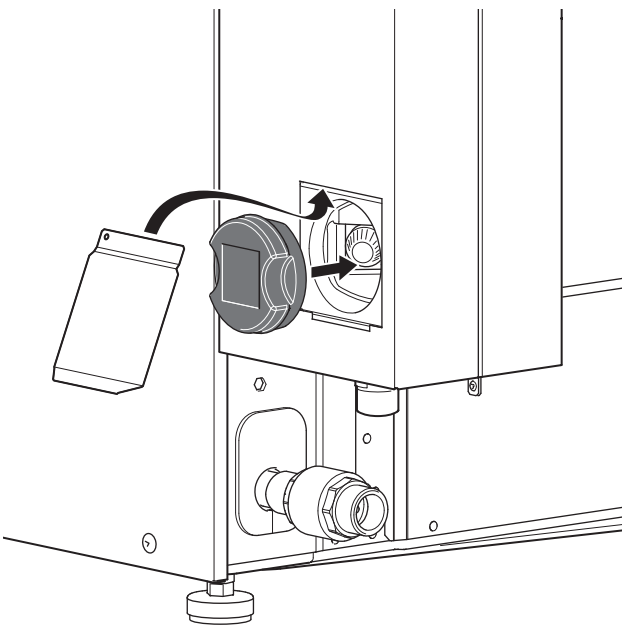

- Screw the flexible pipes into place. The flexible pipes can be installed angled straight back or down, depending on which of the pipe connections the 90° bend is in-

stalled on. Install the flexible pipes with a slight bend, so they can absorb any vibrations that would otherwise be propagated through the building.

CAUTION!
Don't forget the flat gaskets.

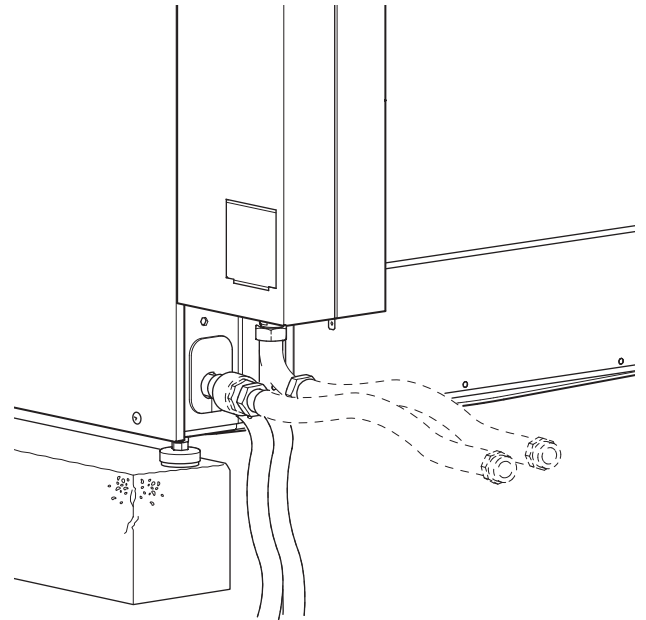

- Check that the venting opening is not covered with pipe insulation. Pipe insulation should extend as far as the coupling and must not cover the opening.

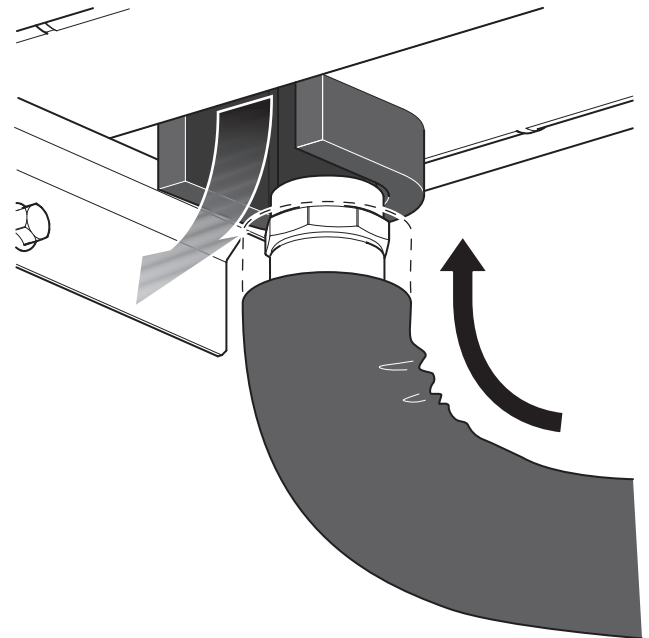

The heat pump design

General

S2125-8, -12 (1x230 V)

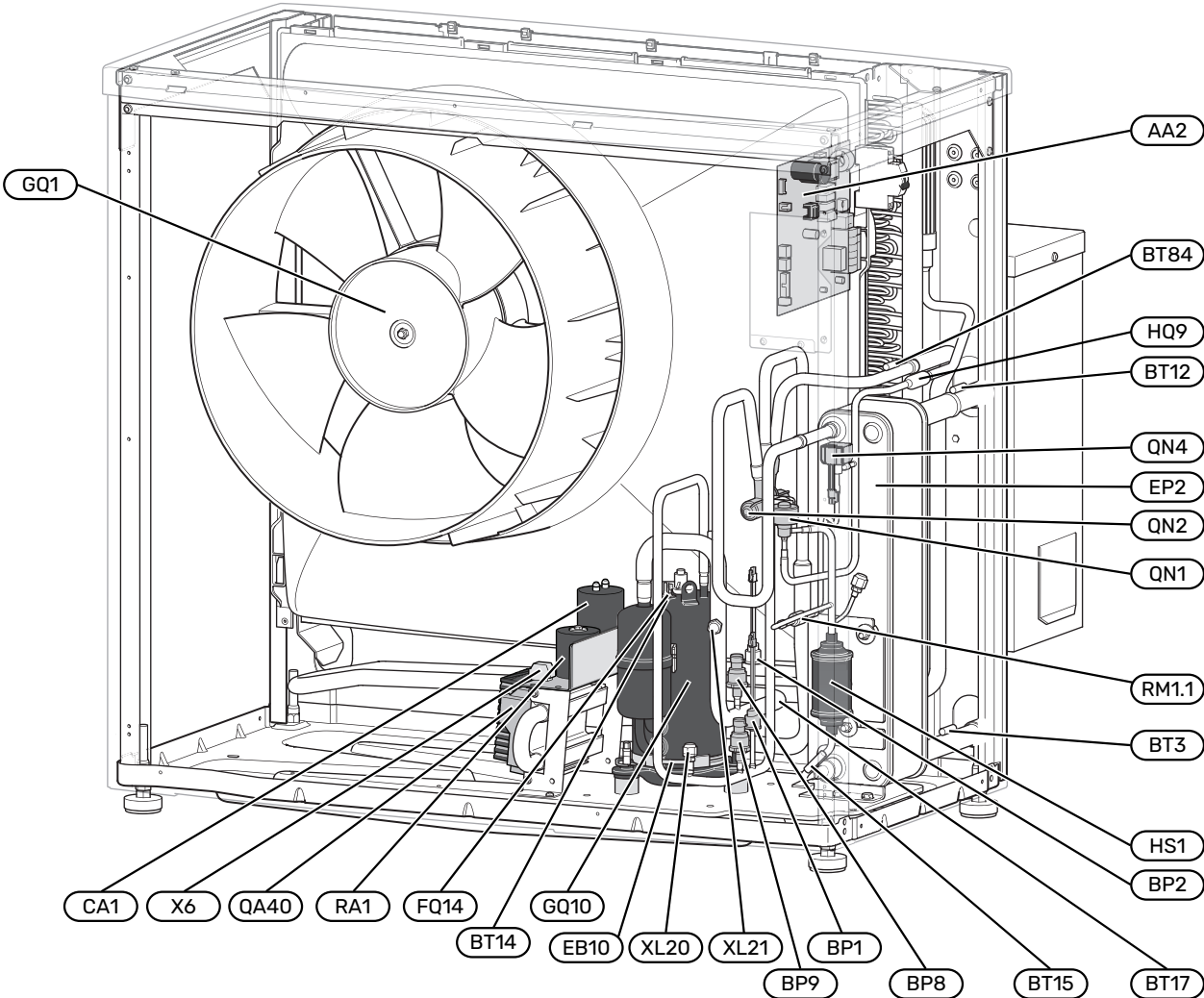

S2125-8, -12 (3x400 V)

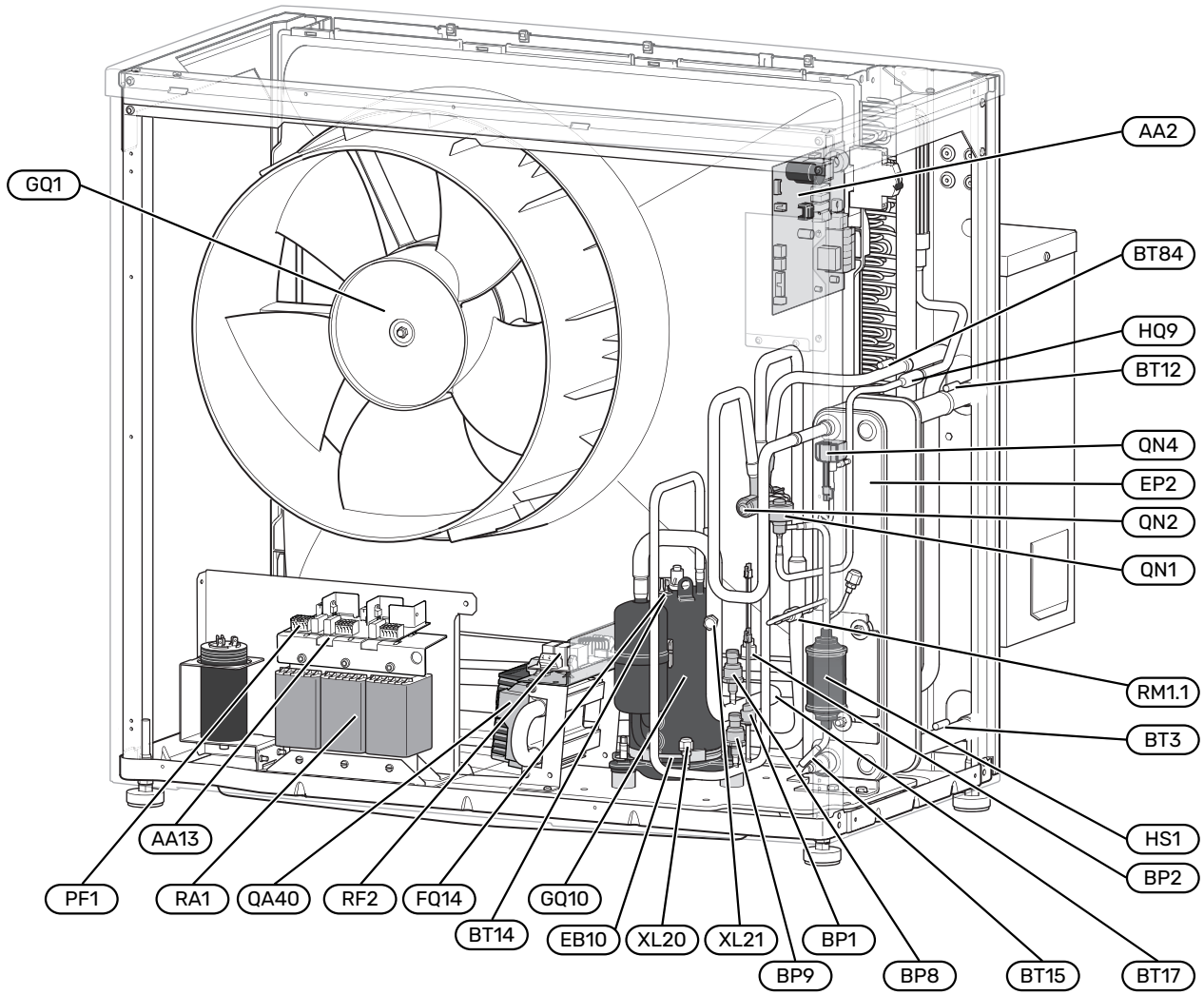

S2125-8, -12

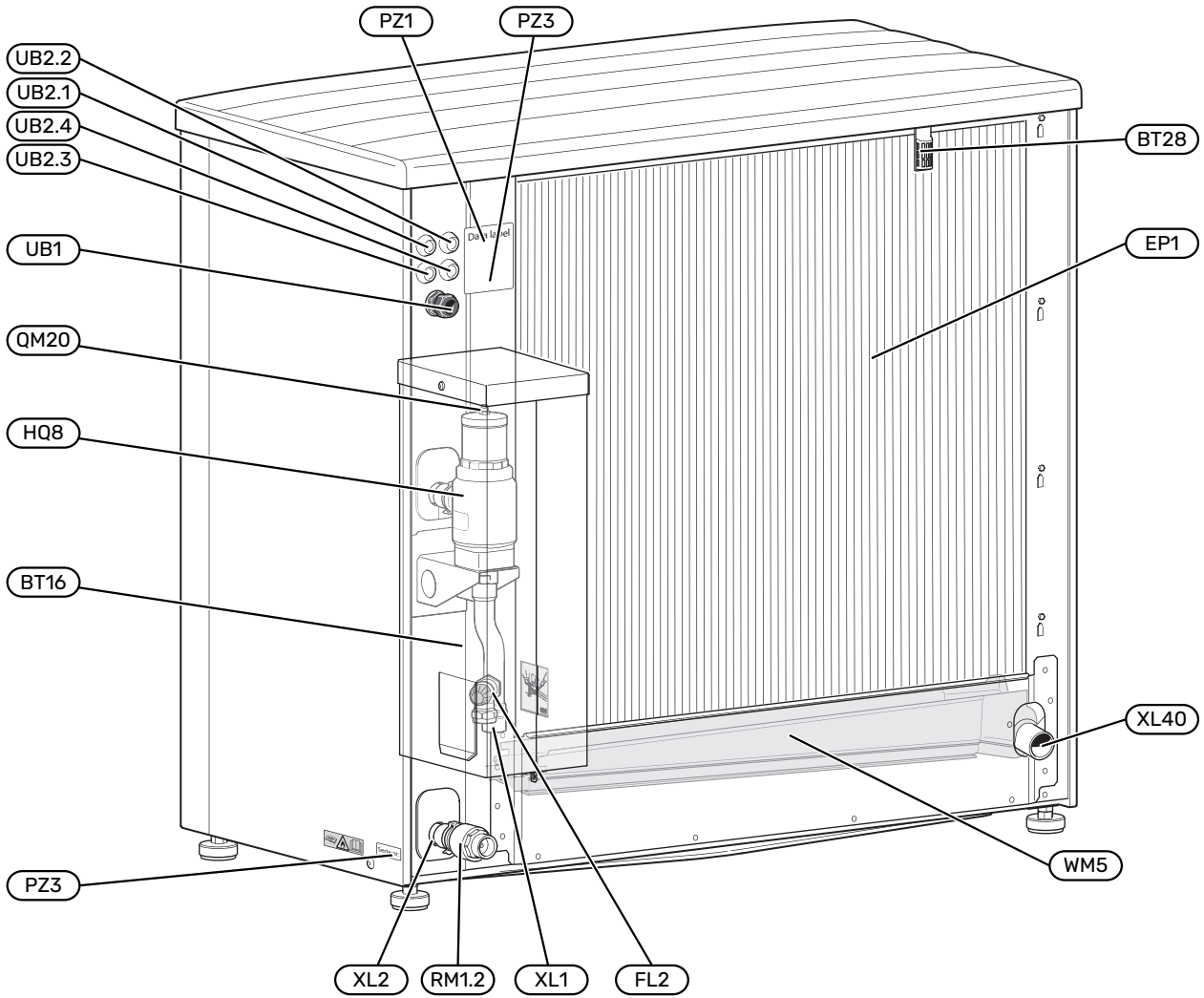

S2125-16, -20 (1x230 V)

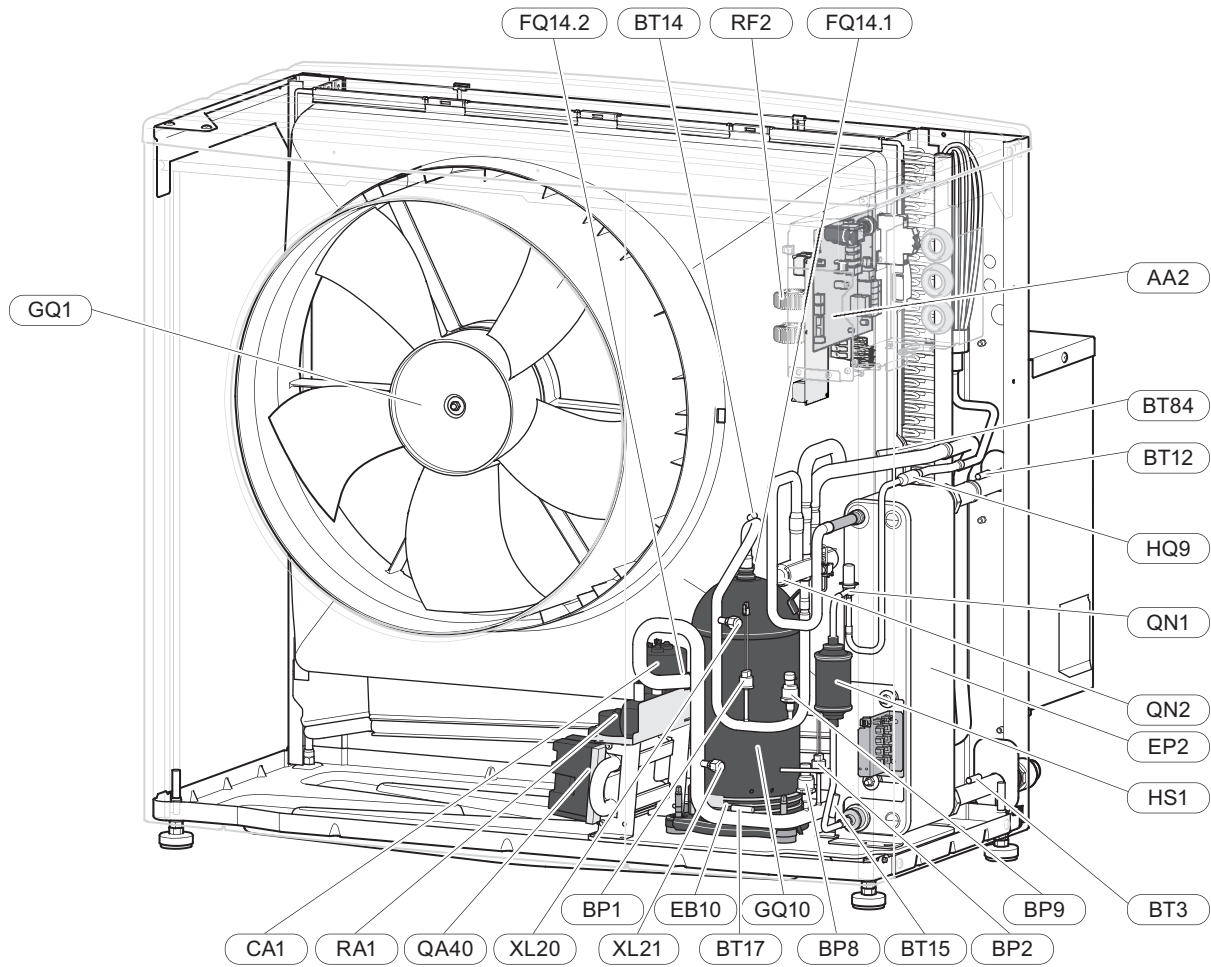

S2125-16, -20 (3x400 V)

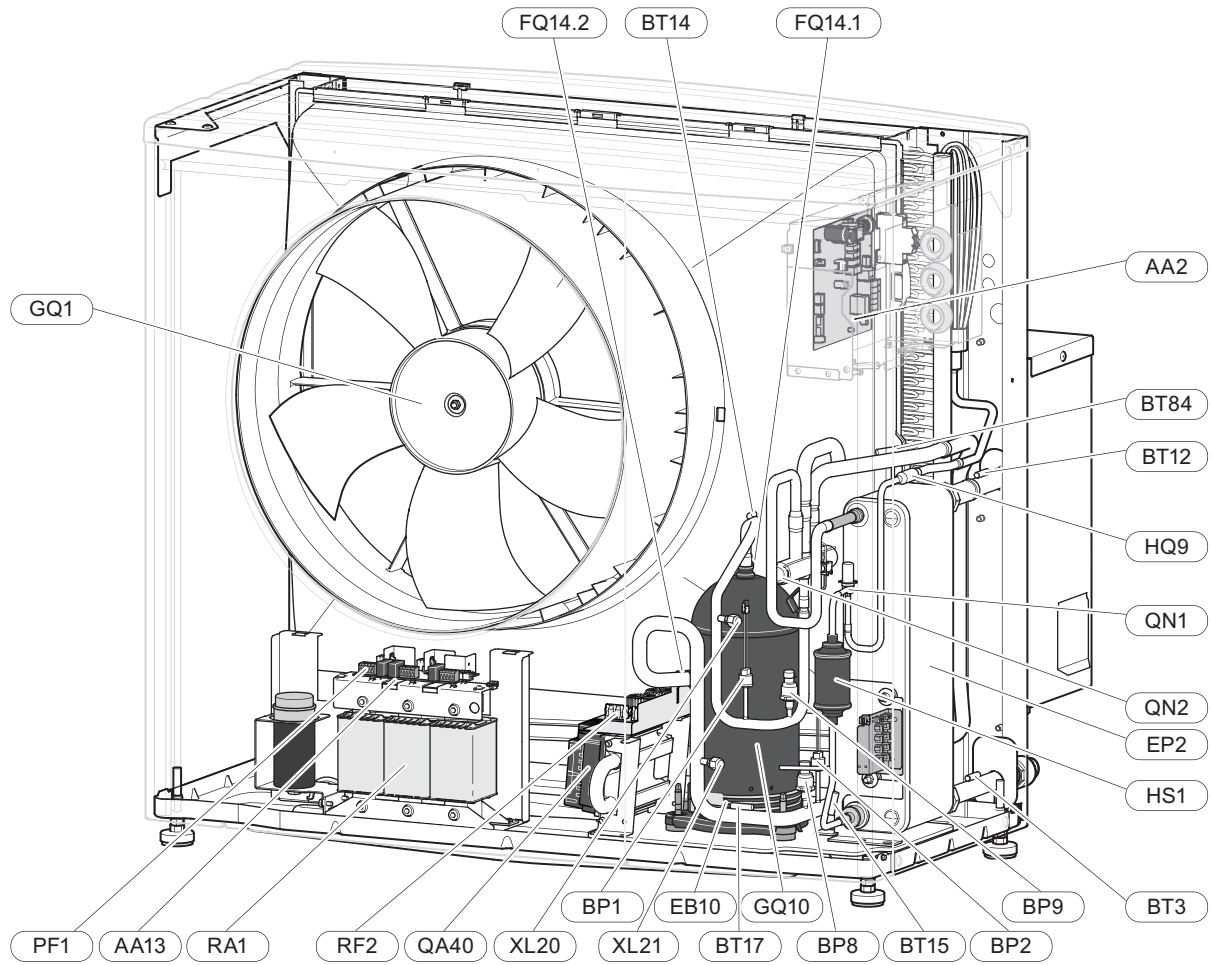

S2125-16, -20

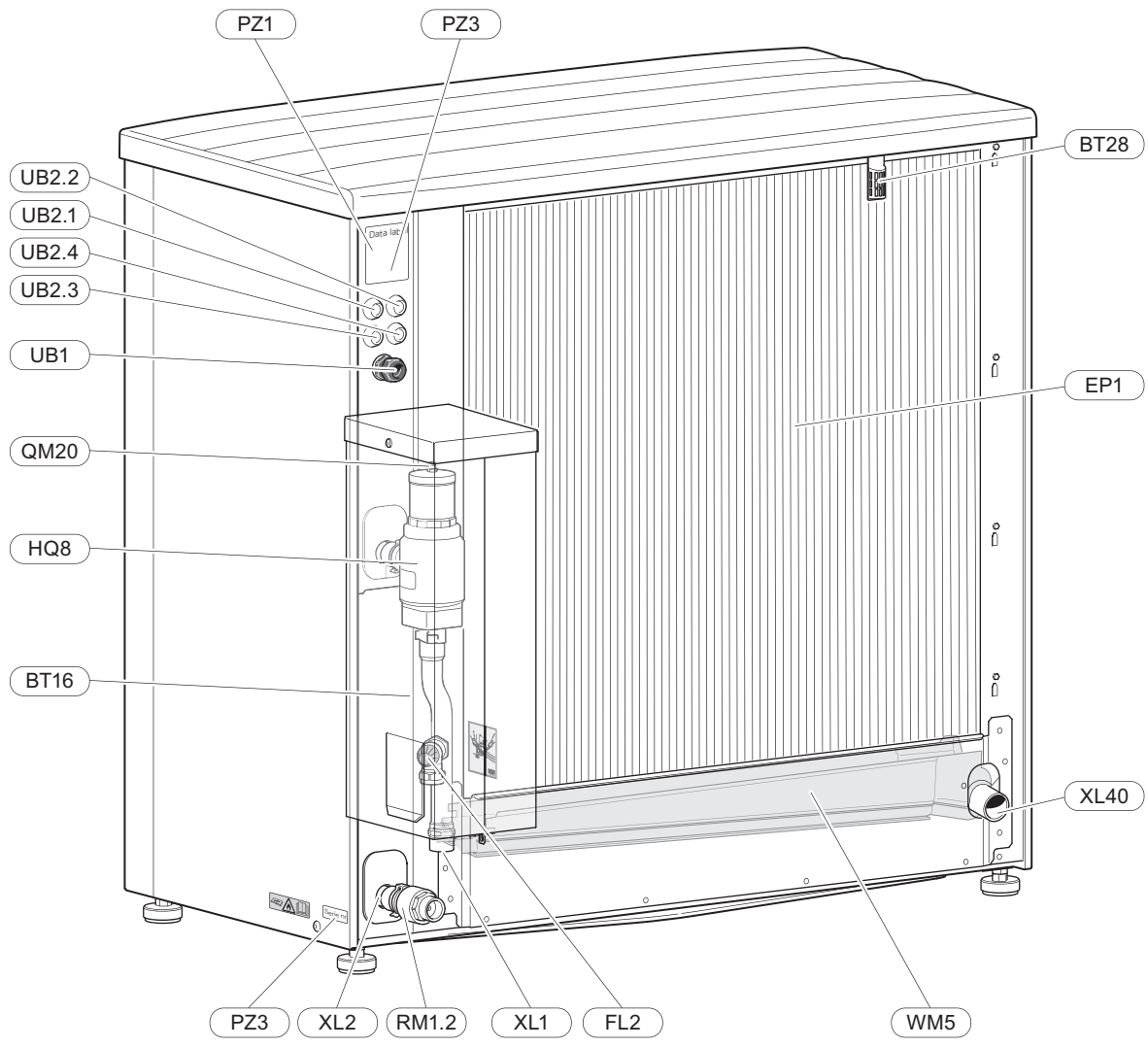

PIPE CONNECTIONS

XL1	Heating medium connection, supply (out from S2125)
XL2	Heating medium connection, return (to S2125)
XL20	Service connection, high pressure
XL21	Service connection, low pressure
XL40	Condensation drain connection

HVAC COMPONENTS

FL2	Safety valve, climate system
HQ8	Automatic gas separator ¹
RM1.2	Non-return valve ¹
QM20	Vent valve, heating medium
WM5	Condensation water trough

¹ Enclosed (not factory-fitted).

SENSORS ETC.

BP1	High pressure pressostat
BP2	Low pressure pressostat
BP8	Low pressure transmitter
BP9	High pressure sensor
BT3	Return line sensor
BT12	Condenser sensor, supply line
BT14	Hot gas sensor
BT15	Fluid line sensor
BT16	Evaporator sensor
BT17	Suction gas sensor
BT28	Ambient sensor
BT84	Suction gas sensor, evaporator

ELECTRICAL COMPONENTS

AA2	Base card
AA13	Triac board
CA1	Capacitor (1x230 V)
EB10	Compressor heater ¹
FQ14	Temperature limiter, compressor ²
FQ14.1	Temperature limiter (Discharge), compressor ³
FQ14.2	Temperature limiter (Suction gas), compressor ³
GQ1	Fan
PF1	Signal lamp (LED)
QA40	Inverter module
RA1	Harmonic filter (3x400 V)
RA1	Choke (1x230 V)
RF2	EMC filter (3x400 V)
RF2	EMC Filter (1x230 V) ³
X6	Terminal block (1x230 V)

¹ S2125-8, -12 has 1 x compressor heater and S2125-16, -20 has 2 x compressor heaters.

² Included only in S2125-8/-12

³ Included only in S2125-16, -20

COOLING COMPONENTS

EP1	Evaporator
EP2	Condenser
GQ10	Compressor
HQ9	Particle filter
HS1	Drying filter
QN1	Expansion valve
QN2	Reversing valve
QN4	Bypass valve
RM1.1	Non-return valve

MISCELLANEOUS

PZ1	Rating plate
PZ3	Serial number plate
UB1	Cable gland, incoming supply
UB2	Cable grommet, communication

Designations according to standard EN 81346-2.

Distribution boxes

S2125-8, -12

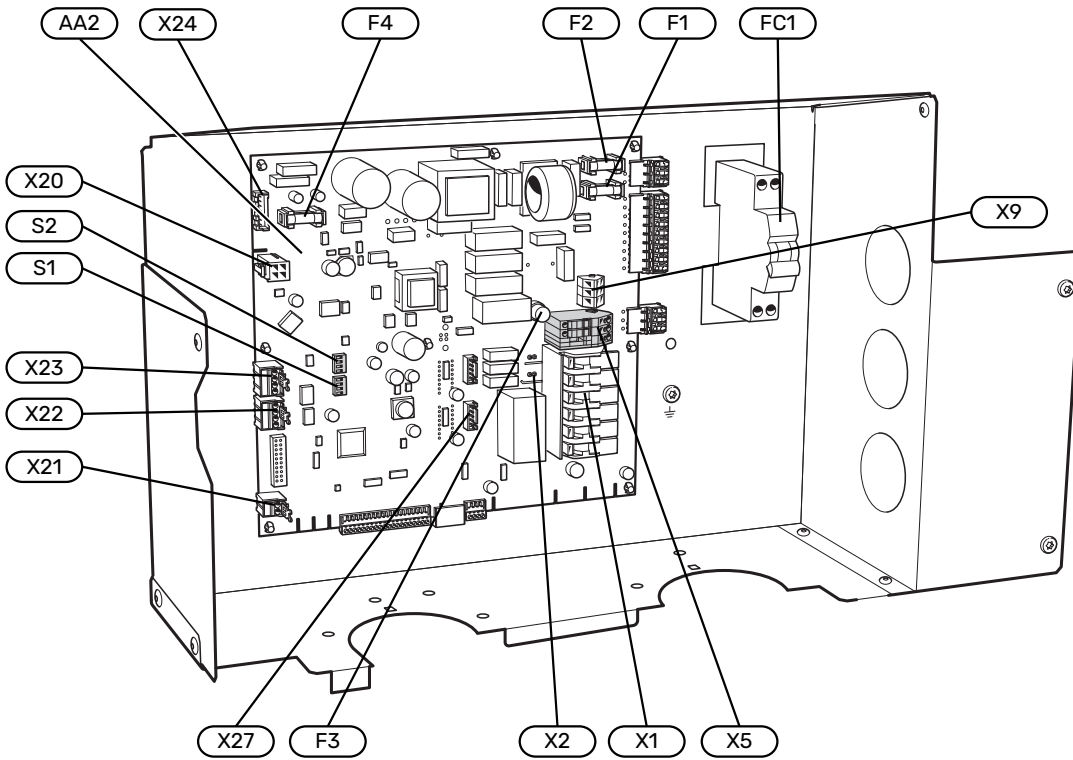

S2125-16, -20

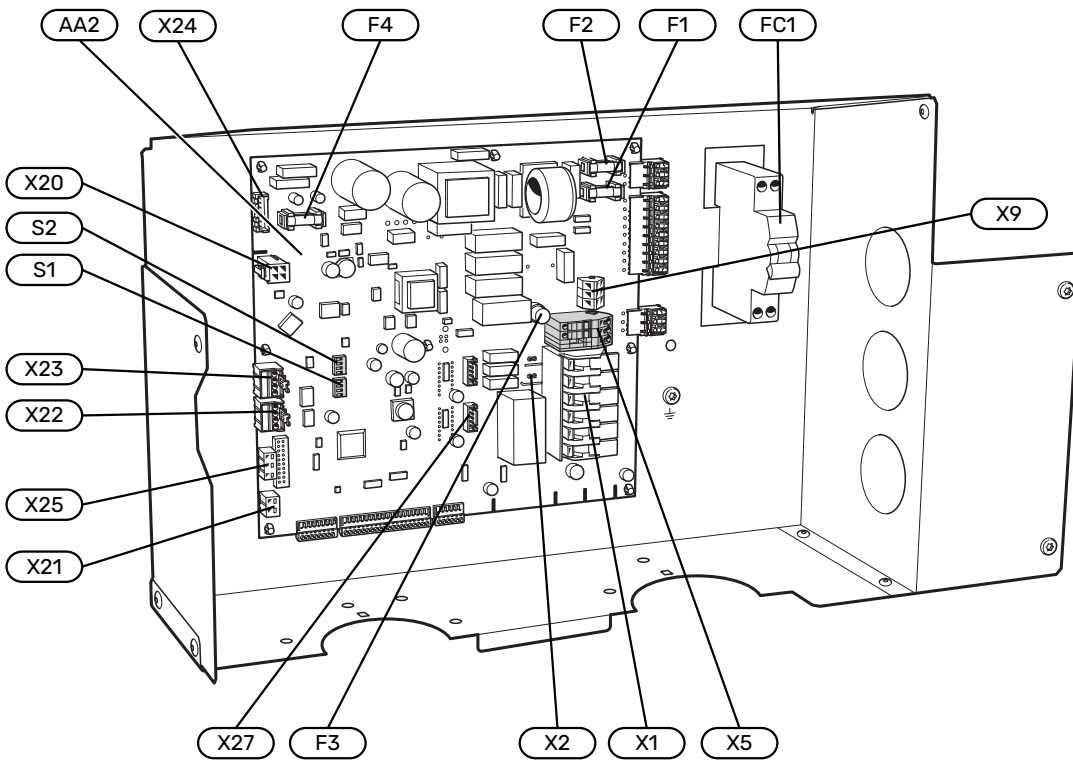

ELECTRICAL COMPONENTS

AA2	Base card
X1	Terminal block, incoming supply
X2	Terminal block, compressor supply
X5	Terminal block, external control voltage
X9	Terminal block, connection KVR
X20	Terminal block, inverter
X21	Terminal block, Compressor blocking, Tariff
X22	Terminal block, communications
X23	Terminal block, communications
X24	Terminal block, fan
X25	Terminal block, flow meter BF1 ¹
X27	Terminal block, expansion valve QN1
	¹ Included only in S2125-16/-20
F1	Fuse, operating 230V~, 4A
F2	Fuse, operating 230V~, 4A
F3	Fuse for external heating cable, KVR, 250mA
F4	Fuse, fan, 4A
FC1	Miniature circuit-breaker (Replaced with automatic protection (FB1) when installing accessory KVR.)
S1	DIP switch, addressing heat pump during multi operation
S2	DIP switch, different options

Pipe connections

General

Pipe installation must be carried out in accordance with current norms and directives.

S2125 is not equipped with shut-off valves on the heating medium side, rather these must be installed to facilitate any future servicing.

MINIMUM SYSTEM FLOW DEFROSTING



CAUTION!

An undersized climate system can result in damage to the product and lead to malfunctions.

The pipe dimension in the climate system(s) should not be less than the recommended pipe diameter. However, each climate system must be dimensioned individually to provide the recommended system flows.

The installation must be dimensioned to provide at least the minimum defrosting flow at 100 % circulation pump operation.

Air/water heat pump	Minimum flow during defrosting 100% circulation pump operation (l/s)	Minimum recommended pipe dimension (DN)	Minimum recommended pipe dimension (mm)
S2125-8	0.32	25	28
S2125-12			
S2125-16	0.38		
S2125-20	0.48	32	35

WATER VOLUMES

To prevent short operating times, and to enable defrosting, a certain available water volume is required. For the optimum operation of S2125, a minimum available water volume is recommended, see table. This applies separately to heating and cooling systems.

Air/water heat pump	Water volume (litres)
S2125-8, -12	120
S2125-16	160
S2125-20	200



CAUTION!

The pipe installation must be flushed out before the heat pump is connected so debris cannot damage component parts.

SYSTEM DIAGRAM

Principle of operation with indoor module, hot water and climate system.

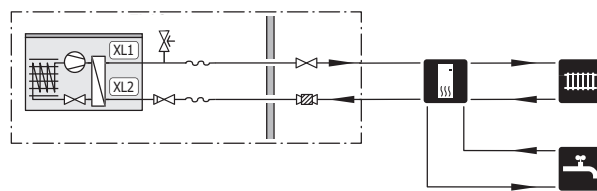

- XL1 Heating medium connection, supply (out from S2125)
- XL2 Heating medium connection, return (to S2125)

Symbol key

Symbol	Meaning
	Shut-off valve
	Circulation pump
	Expansion vessel
	Filterball
	Pressure gauge
	Safety valve
	Diverter valve/shunt
	Indoor module
	Control module
	Domestic hot water
	Outdoor module
	Water heater
	Heating system

Pipe coupling heating medium circuit

S2125-12 in combination with VVM 225 requires that the system must be supplemented with NIBE UKV.

See "Flow equalisation" in the "Buffer vessel (UKV)" section in the Installer Manual for VVM 225.



NOTE!

There is a difference between connection to a control module compared with connection to an indoor module.

See the Installer Manual for the indoor module/control module.

Install as follows:

- expansion vessel
- pressure gauge
- safety valves
- charge pump
- shut-off valve

To facilitate any future servicing.

- enclosed filterball (QZ2)

Installed before connection "heating medium return" (XL2) (the lower connection) on the vacuum pump.

- diverter valve.

When connecting to the control module, and if the system is to be able to work with both the climate system and the hot water heater.

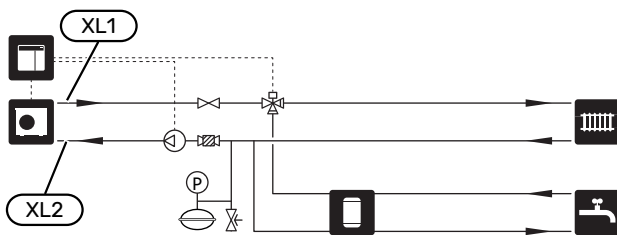

The image shows connection to the control module.

PIPE CONNECTIONS FLEX HOSE

The supplied flexible hoses act as vibration dampers. The flexible pipes are fitted so an elbow is created, thus acting as vibration damping.

All outdoor pipes must be insulated with at least 19 mm thick pipe insulation.

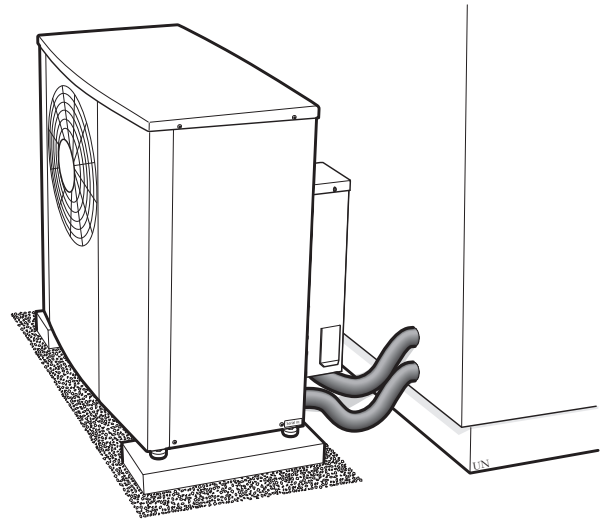

Electrical connections

General

- Electrical installation and wiring must be carried out in accordance with national provisions.
- Prior to insulation testing the house wiring, disconnect the air/water heat pump installation.
- If a miniature circuit breaker is used, this must have at least triggering characteristic "C". See section "Technical specifications" for fuse size.
- S2125 must be fitted with a residual current device. If the property is equipped with a residual current device, S2125 must be equipped with a separate one.
- The RCD must have a nominal tripping current of no more than 30 mA.
- S2125 must be installed via an isolator switch. The cable area has to be dimensioned based on the fuse rating used.
- The communication cable must be a screened cable with three conductors. (0,75 mm²)
- To prevent interference, communication cables to external connections must not be laid in the vicinity of high voltage cables.
- Connect the charge pump to the control module. See where the charge pump is to be connected in the Installer Manual for your control module.
- When cable routing in S2125, the cable grommets (UB1 and UB2) must be used.

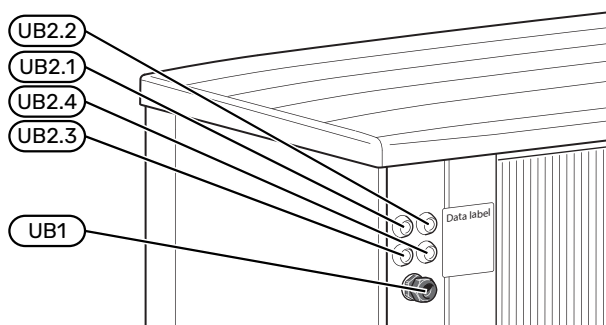

CAUTION!

The live external control must be taken into consideration when connecting.



CAUTION!

If the supply cable is damaged, only NIBE, its service representative or similar authorised person may replace it to prevent any danger and damage.



CAUTION!

Do not start the system before filling up with water. Components in the system could be damaged.

Accessibility, electrical connection

See section "Removing panels".



CAUTION!

Electrical installation and any servicing must be carried out under the supervision of a qualified electrician. Turn off the power with the circuit breaker before servicing.



CAUTION!

Check the connections, main voltage and phase voltage before the product is started, to prevent damage to the heat pump electronics.

Connections

TERMINAL BLOCKS

The following terminal blocks are used on the base board (AA2).

S2125-8, -12

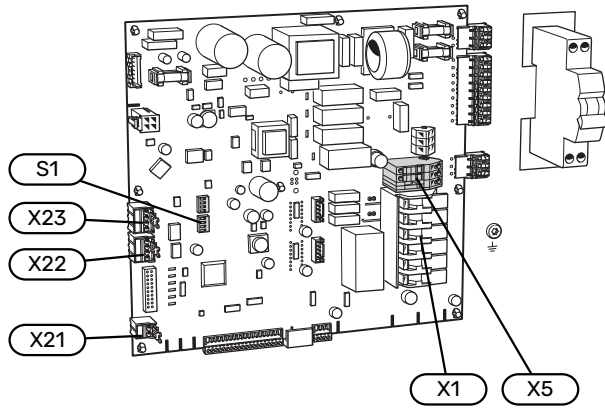

S2125-16, -20

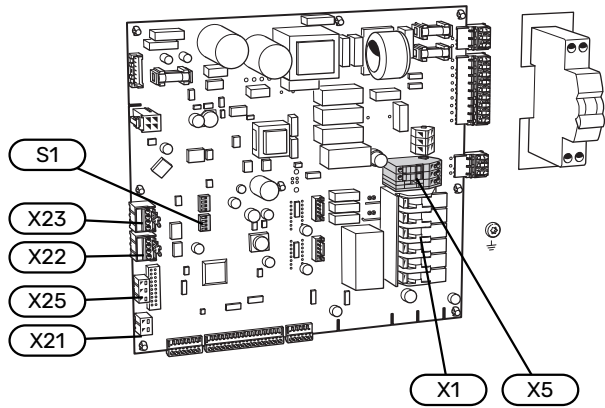

External control voltage for the control system

If the control system is to be powered separately from other components in S2125 (e.g. for tariff control), a separate operating cable is connected.



CAUTION!

During service, all supply circuits must be disconnected.

1. Remove the bridges from terminal block AA2-X5.

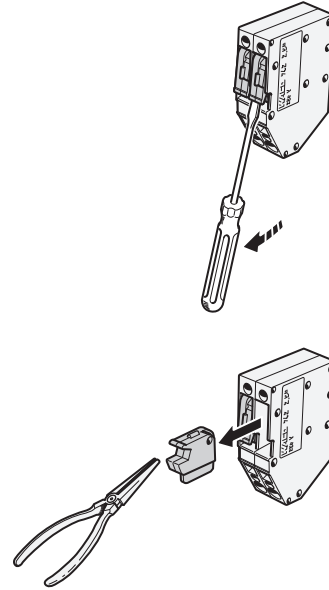

2. Connect control voltage (230V ~ 50Hz) to X5:N, X5:L and X5:PE.

POWER CONNECTION

Supply voltage

The enclosed cable (length 1.8 m) for incoming electricity is connected to terminal block X1.

1x230 V

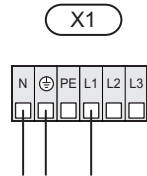

3x400 V

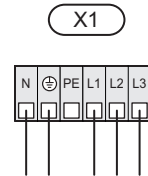

During installation, fit the screwed connection (UB1) on the rear of the heat pump. The part of the screwed connection that tensions the cable must be tightened to a tightening torque greater than 3.5Nm.

Enclosed labels

The small label is placed on the outside of the side panel.

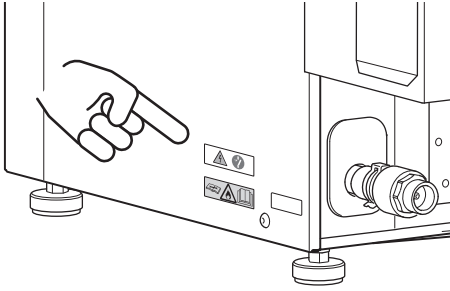

The large label is placed on the inside of the side panel, next to the insulation.

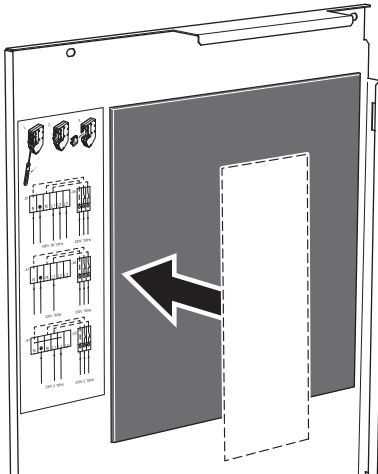

Tariff control

If the voltage to the compressor is lost for a period, "Tariff blocking" must be selected at the same time via the selectable inputs in the indoor module / control module or an external contact must be connected to the air/water heat pump.

The closing contact connects to AA2-X21:1 and X21:2.

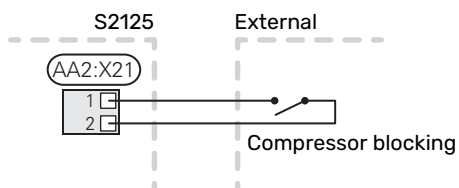

COMMUNICATION

Disconnect the connections in S2125

Remove the connectors (X22, X23) in S2125 when connecting communication to an indoor module / control module.

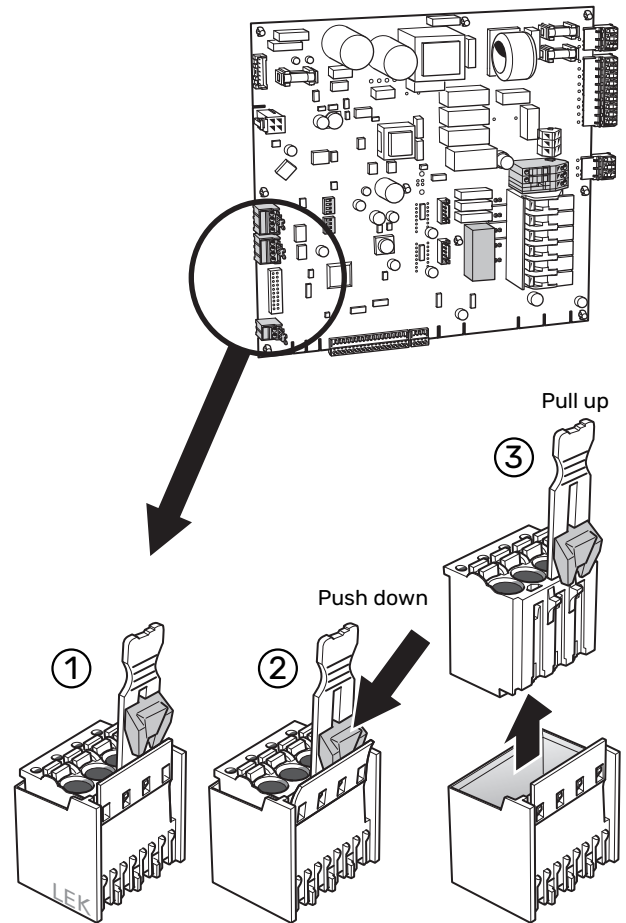

Cable routing, communication

1. Route the communication cable in through “cable grommet, communication” (UB2) on the rear of the S2125.
2. Connect the communication cable to the terminal block for communication (AA2-X22:1-3) in S2125.
3. Connect the cable’s screen to the terminal block for communication (AA2-X22:4) in S2125.

S2125

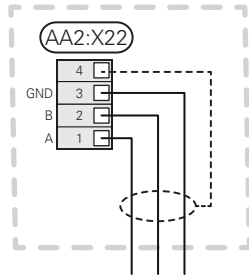

For connection in the indoor module/control module:

See the Installer Manual for the indoor module/control module.

Cascade connection

1. Connect terminal block (AA2-X23:1-3 with the next heat pump’s terminal block (AA2-X22:1-3) for cascade connection.
2. Connect the cable’s screen to (AA2-X23:4) in each S2125.

S2125

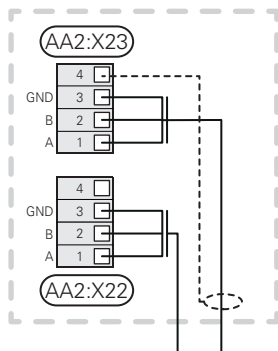

S2125

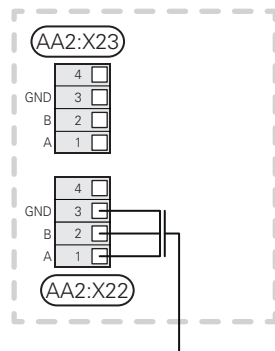

DIP SWITCH

S2125 is equipped with a DIP switch (S1) on the base board (AA2).



CAUTION!

Only change the position of the DIP switch when S2125 is not powered up.

Cascade connection

In installations with multiple outdoor units, each outdoor unit must have a unique address, which is set with the DIP switch.

Outdoor module	Position (1 / 2 / 3)	Address (com)	Default setting
1 (EB101)	off / off / off	01	OFF
2 (EB102)	on / off / off	02	OFF
3 (EB103)	off / on / off	03	OFF
4 (EB104)	on / on / off	04	OFF
5 (EB105)	off / off / on	05	OFF
6 (EB106)	on / off / on	06	OFF
7 (EB107)	off / on / on	07	OFF
8 (EB108)	on / on / on	08	OFF

Cooling

S2125 can supply cooling with cooling supply down to +7°C.

To enable cooling operation, the DIP switch must be set.

Function	Position (4)	Default setting
Permits cooling	ON	OFF

Commissioning and adjusting

Preparations



NOTE!

Check the miniature circuit-breaker (FC1). It could have tripped during transport.

COMPRESSOR HEATER

S2125 is equipped with compressor heaters that heat the compressor before start-up and when the compressor is cold.

Compressor heater (EB10) is activated when the heat pump is connected to the supply voltage. The compressor needs to be heated up before starting for the first time. From the time the indoor module/control module is connected and a heating demand arises, it may take a while before the compressor reaches the permitted start value.

Filling and venting

Fill the heating system to the necessary pressure.

The heat pump is vented automatically with the aid of the gas separator (HQ8). The gas separator closes automatically when the valve housing has been vented and filled with liquid.

Readjusting, heating medium side

Air is initially released from the hot water and venting may be necessary. If bubbling sounds can be heard from the heat pump, the charge pump or radiators, the entire system requires further venting. When the system has stabilised (correct pressure and all air eliminated), the automatic heating control system can be set as required.

Commissioning



CAUTION!

Do not start S2125 if there is a risk that the water in the system has frozen.

1. Check that the communication cable between the outdoor unit and the indoor module/control module is connected.
2. If cooling operation with S2125 is wanted, DIP switch S1 position 4 must be changed, according to the description in section "Cooling".
3. Power-up S2125 and the indoor module/control module.
4. Check that the miniature circuit-breaker (FC1) is in the on position.
5. Reinstall the removed panels and cover.
6. After the power to S2125 has been switched on, and there is a compressor demand from the indoor module/control module, the compressor starts once it has warmed up.
7. Adjust the charge flow according to size. Also see section "Adjustment, charge flow".
8. Follow the instructions in the start guide in the indoor module's/control module's display.
9. Fill in "Inspection of the installation", in section "Important information".

The live external control must be taken into consideration when connecting.

Adjustment, charge flow

For correct function of the heat pump over the entire year, the charge flow must be correctly adjusted.

If an NIBE indoor module or accessory-controlled charge pump is used for the control module, the control tries to maintain an optimal flow across the heat pump.

Adjustment may be required, especially for charging a separate water heater. It is therefore recommended to have the option of adjusting the flow across the water heater using a trim valve.

1. Recommendation if there is insufficient hot water and information message "high condenser out" during hot water charging: increase the flow
2. Recommendation if there is insufficient hot water and information message "high condenser in" during hot water charging: reduce the flow

Charge pump

The charge pump (not included in the product) is powered and controlled from the indoor module/control module. It has a built-in frost protection function and, for this reason, must not be switched off when there is a risk of freezing.

At outdoor temperatures below +2 °C, the charge pump runs periodically, to prevent the water from freezing in the charge circuit. The function also protects against excess temperatures in the charge circuit.

Pressure drop, heating medium side

The diagram shows the pressure drop on the heating medium side, including the gas separator.

S2125-8, -12

Pressure drop (kPa)

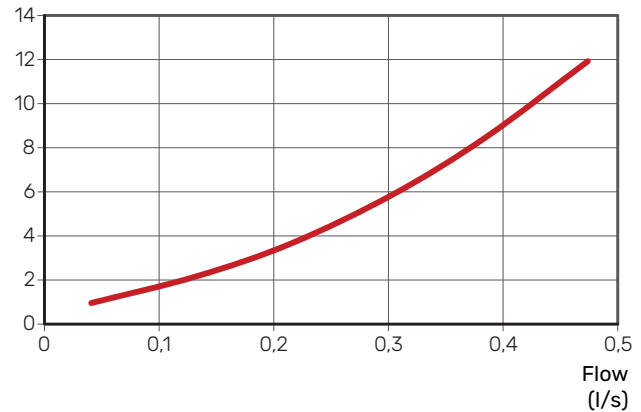

S2125-16, -20

Pressure drop (kPa)

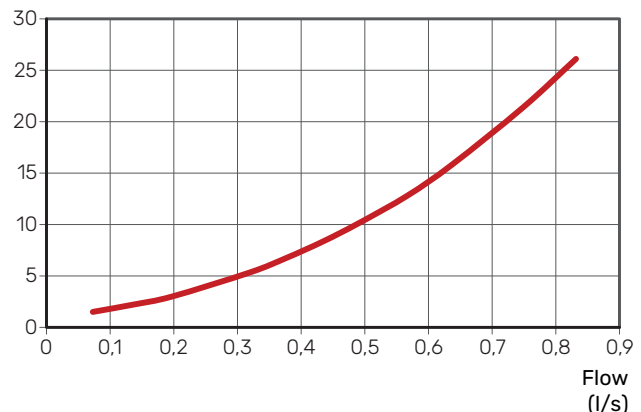

Control

General

S2125 is equipped with an internal electronic controller that handles all functions necessary for operation of the heat pump, e. g. defrosting, stop at max/min temperature, connection of the compressor heater, and protective functions during operation.

The integrated control shows information via status-LEDs and can be used during servicing.

Under normal operating conditions the home owner does not need to have access to the controller.

S2125 communicates with the NIBE indoor module/control module, which means that all settings and measurement values from S2125 are adjusted and read off on the indoor module/control module.



NOTE!

The main product's software must be the latest version.

Master control

To control S2125, a NIBE indoor module/control module is required, which calls upon S2125 according to demand. All settings for S2125 are made via the indoor module/control module. It also shows the status and sensor values from S2125.

Control conditions

CONTROL CONDITIONS DEFROSTING

- If the temperature of the evaporator sensor (BT16) is below the start temperature for the defrosting function, S2125 counts the time to "active defrosting" for each minute that the compressor is running, to create a defrosting requirement.
- Time until "active defrosting" is shown in minutes on the indoor module / control module. Defrosting starts when this value is 0 minutes.
- "Passive defrosting" is started, if the compressor requirement has been fulfilled, at the same time as there is a defrosting requirement and the outdoor temperature (BT28) is greater than 4 °C.
- Defrosting occurs actively (with compressor on and fan off) or passively (with compressor off and fan on).
- If the evaporator becomes too cold during operation, a "safety defrost" is started to reduce the amount of ice formation on the evaporator. A safety defrost can lead to defrosting being performed more often than normal, for a limited period of time. If safety defrosting occurs ten times in a row, the evaporator (EP1) on S2125 must be checked, which is indicated by an alarm.
- If "de-icing fan" is activated in the indoor module/control module, "de-icing fan" starts at the next "active defrosting". "De-icing fan" removes the build-up of ice on the fan blades and the front fan grille.

Active defrosting:

1. The reversing valve shifts to defrosting.
2. The fan stops and the compressor continues to run.
3. When defrosting is complete, the reversing valve switches back to heating operation. The compressor speed is locked for a short period.
4. The ambient temperature is locked and the high return temperature alarm is blocked for two minutes after defrosting.

Passive defrosting:

1. If there is no compressor demand, passive defrosting can start.
2. The reversing valve does not shift.
3. Fan runs at high speed.
4. If there is a compressor demand, passive defrosting stops and the compressor starts.
5. When passive defrosting is complete, the fan stops.
6. The ambient temperature is locked and the high return temperature alarm is blocked for two minutes after defrosting.

Activating S2125

S-SERIES – INDOOR MODULE / CONTROL MODULE

Settings for S2125 can be made via the start guide or directly in the menu system.

The main product's software must be the latest version.

Start guide

The start guide appears upon first start-up after heat pump installation, but is also found in menu 7.7.

Menu system

If you do not make all settings via the "Start guide", or if you need to change any of the settings, you can do this in the menu system.

Menu 7.3.2 - Installed heat pump

Here, you make specific settings for the installed heat pump.

Menu 7.3.2.1 - Heat pump settings

Here, you make settings that are specific for the installed heat pumps.

Silent mode permitted

Alternative: on/off

Max. frequency 1

Setting range: 25 Hz –

The setting range depends on the outdoor unit's size and sound requirements.

Max. frequency 2

Setting range: 25 Hz –

The setting range depends on the outdoor unit's size and sound requirements.

Compressor phase

Setting range S2125 1 x 230 V: L1, L2, L3

Detect compressor phase

Alternative S2125 1 x 230 V: on/off

Current limit

Alternative S2125 1 x 230 V: on/off

Max. current

Setting range S2125 1 x 230 V: 6 – 34 A

BlockFreq 1 and 2

Setting range, heating: 25 – 120 Hz

Flow meter

Options: None, EMK 300, EMK 500

Start manual defrosting

Alternative: on/off

Start temperature for defrost function

Setting range: -3 – 0 °C

Cut-out value activation passive defrosting

Setting range: 2 – 10 °C

Defrost more often

Alternatives: Yes / No

Silent mode permitted: Here, you set whether silent mode will be activated for the heat pump. Note, it is now possible to schedule when silent mode will be active. The function should only be used for limited periods, because S2125 might not reach its dimensioned power.

Detect compressor phase: This shows in which phase the heat pump detected that you have S2125 1x230 V. Phase detection normally occurs automatically in connection with start-up of the indoor module/control module. This setting can be changed manually.

Current limitation: Here, you set whether the current limitation function will be activated for the outdoor unit, if you have S2125 1x230 V. During active function, you can limit the value of the maximum current.

BlockFreq 1-2: Here, you can select the frequency ranges within which the outdoor unit is not permitted to work. This function can be used if certain compressor speeds cause disruptive noise in the house. The setting range varies depending on heat pump model and size.

Flow meter: Here, you choose the accessory that is installed.

Defrosting

Here you can change the settings that affect the defrost function.

Start manual defrosting: Here, you can start "active defrosting" manually, if the function needs to be tested for servicing or if necessary. This can also be used to accelerate the start of "fan de-icing".

Start temperature for defrost function: Here, you set the temperature (BT16) at which the defrost function will start. The value must only be changed in consultation with the installer.

Cut-out value activation passive defrosting: Here, you set the temperature (BT28) at which "passive defrosting" will be activated. During passive defrosting, the ice is melted by the energy from the ambient air. The fan is active during passive defrosting. The value must only be changed in consultation with the installer.

Defrost more often: Here, you activate whether defrosting will occur more frequently than normal. This selection can be made if the heat pump receives an alarm due to build-up of ice during operation caused, for example, by snow.

Menu 4.11.3 - Fan de-icing

Fan de-icing

Options: on/off

Continuous fan de-icing

Options: on/off

Operate fan during defrosting

Options: on/off

Fan de-icing: Here, you set whether the "fan de-icing" function will be activated during the next "active defrosting". This can be activated if ice/snow sticks to the fan, grille or fan cone, which may be noticed due to abnormal fan noise from the outdoor unit.

"Fan de-icing" means that the fan, grille and fan cone are heated using hot air from the evaporator (EP1).

Continuous fan de-icing: There is the option to set recurring de-icing. In this case, every tenth defrosting will be "Fan de-icing". (This can increase annual energy consumption.)

Operate fan during defrosting: Activate "Operate fan during defrosting" if you experience problems with the fan in connection with defrosting. The fan will then never stop during the defrosting process. For S2125-8, -12, this will apply when the ambient temperature is above -10 °C and for S2125-16, -20 when the ambient temperature is above -25 °C. (This can increase annual energy consumption.)

F-SERIES – INDOOR MODULE / CONTROL MODULE

Settings for S2125 can be made via the start guide or directly in the menu system.

The main product's software must be the latest version.

Start guide

The start guide appears upon first start-up after heat pump installation, but is also found in menu 5.7.

Menu system

If you do not make all settings via the "Start guide", or if you need to change any of the settings, you can do this in the menu system.

Menu 5.11.1.1 - heat pump

Here, you make specific settings for the installed heat pump.

Silent mode permitted

Setting range: yes / no

Detect compressor phase

Setting range S2125 1 x 230 V: off/on

Current limit

Setting range: 6 – 34 A

Factory setting: 32 A

blockFreq 1

Setting range: yes / no

blockFreq 2

Setting range: yes / no

Defrosting

Start manual defrosting

Setting range: on/off

Start temperature for defrost function

Setting range: -3 – 3 °C

Factory setting: -3 °C

Cut-out value activation passive defrosting

Setting range: 2 – 10 °C

Factory setting: 4 °C

Defrost more often

Setting range: Yes / No

Silent mode permitted: Here, you set whether silent mode will be activated for the heat pump. Please note that you now have the option to schedule when silent mode will be active.

The function should only be used for limited periods, because S2125 possibly may not reach its dimensioned output.

Detect compressor phase: This shows in which phase the heat pump detected that you have S2125 230V-50Hz. Phase detection normally occurs automatically in connection with start-up of the indoor module/control module. This setting can be changed manually.

Current limitation: Here, you set whether the current limitation function will be activated for the heat pump, if you have S2125 230V-50Hz. During active function, you can limit the value of the maximum current.

BlockFreq 1: Here, you can select a frequency range within which the heat pump is not permitted to work. This function can be used if certain compressor speeds cause disturbing noise in the house.

BlockFreq 2: Here, you can select a frequency range within which the heat pump is not permitted to work.

Defrosting

Here you can change the settings that affect the defrost function.

Start manual defrosting: Here, you can start "active defrosting" manually, if the function needs to be tested for servicing or if necessary. This can be justified together with "fan de-icing".

Start temperature for defrost function: Here, you set the temperature (BT16) at which the defrost function will start. The value must only be changed in consultation with the installer.

Cut-out value activation passive defrosting: Here, you set the temperature (BT28) at which "passive defrosting" will be activated. During passive defrosting, the ice is melted by the energy from the ambient air. The fan is active during passive defrosting. The value must only be changed in consultation with the installer.

Defrost more often: Here, you activate whether defrosting will occur more frequently than normal. This selection can be made if the heat pump receives an alarm due to build-up of ice during operation caused, for example, by snow.

Menu 4.9.7 - tools

Fan de-icing

Setting range: off/on

Continuous fan de-icing

Setting range: off/on

Operate fan during defrosting

Setting range: off/on

This function ensures that any ice on the fan or fan grille is removed.

Fan de-icing: Here, you set whether the "fan de-icing" function will be activated during the next "active defrosting". This can be activated if ice/snow sticks to the fan, grille or fan cone, which may be noticed due to abnormal fan noise from the outdoor unit.

"Fan de-icing" means that the fan, grille and fan cone are heated using hot air from the evaporator (EP1).

Continuous fan de-icing: There is the option to set recurring de-icing. In this case, every tenth defrosting will be "Fan de-icing". (This can increase annual energy consumption.)

Operate fan during defrosting: Activate "Operate fan during defrosting" if you experience problems with the fan in connection with defrosting. The fan will then never stop during the defrosting process. For S2125-8, -12, this will apply when the ambient temperature is above -10 °C and for S2125-16, -20 when the ambient temperature is above -25 °C. (This can increase annual energy consumption.)

Service

Service actions



CAUTION!

Servicing should only be carried out by persons with the necessary expertise.

When replacing components on S2125 only replacement parts from NIBE may be used.

DRAINING THE CONDENSER

In the event of a prolonged power failure or similar, for example, the condenser in S2125 may need to be drained of water.



CAUTION!

There may be some hot water, risk of scalding.

1. Close the shut-off valves.
2. Release the pressure using the vent valve (QM20) on the automatic gas separator (HQ8).
3. Release the clip and pull out the non-return valve (RM1.2) on the heating medium connection, return (to S2125) (XL2).

ACTUATING THE SAFETY VALVE (FL2)

The safety valve (FL2) must be actuated regularly, to remove dirt and to check that it is not blocked.

Remember to also check that the vent valve (QM20) is working.

TEMPERATURE SENSOR DATA

Return line (BT3), condenser supply (BT12), liquid line (BT15)

Temperature (°C)	Resistance (kOhm)	Voltage (VDC)
-10	56.20	3.047
0	33.02	2.889
10	20.02	2.673
20	12.51	2.399
30	8.045	2.083
40	5.306	1.752
50	3.583	1.426
60	2.467	1.136
70	1.739	0.891
80	1.246	0.691

Discharge sensor (BT14)

Temperature (°C)	Resistance (kOhm)	Voltage (V)
40	118.7	4.81
45	96.13	4.77
50	78.30	4.72
55	64.11	4.66
60	52.76	4.59
65	43.64	4.51
70	36.26	4.43
75	30.27	4.33
80	25.38	4.22
85	21.37	4.10
90	18.07	3.97
95	15.33	3.83
100	13.06	3.68
105	11.17	3.52
110	9.59	3.36
115	8.26	3.19
120	7.13	3.01

Evaporator sensor (BT16), ambient sensor (BT28), suction gas sensor (BT17) and suction gas, evaporator (BT84)

Temperature (°C)	Resistance (kOhm)	Voltage (VDC)
-40	43.34	4.51
-30	25.17	4.21
-20	15.13	3.82
-10	9.392	3.33
0	6.000	2.80
10	3.935	2.28
20	2.644	1.80
30	1.817	1.39
40	1.274	1.07

Disturbances in comfort

In most cases, the indoor module/control module notes a malfunction (a malfunction can lead to disturbance in comfort) and indicates this with alarms and action instructions in the display.

Troubleshooting



CAUTION!

In the event of action to rectify malfunctions that require work within screwed hatches, the incoming supply electricity must be isolated at the safety switch by or under the supervision of a qualified electrician.



NOTE!

Alarms are acknowledged on the indoor module / control module.

If the operational interference is not shown in the display the following tips can be used:

BASIC ACTIONS

Start by checking the following:

- All supply cables to the heat pump are connected.
- Group and main fuses of the accommodation.
- The property's earth circuit breaker.
- The heat pump's fuse / automatic protection. (FC1 / FB1, FB1 only if KVR is installed.)
- The indoor module's/control module's fuses.
- The indoor module's/control module's temperature limiters.
- That the air flow to S2125 is not blocked by foreign objects.
- That S2125 does not have any external damage.

S2125 DOES NOT START

- There is no demand.
 - The indoor module/control module does not call on heating, cooling or hot water.
- Compressor blocked due to the temperature conditions.
 - Wait until the temperature is within the product's working range.
- Minimum time between compressor starts has not been reached.
 - Wait for at least 30 minutes and then check if the compressor has started.
- Alarm tripped.
 - Follow the display instructions.

S2125 NOT COMMUNICATING

- Check that S2125 is correctly installed in the indoor module or the control module.
- Check that the communication cable is correctly connected and working.

LOW HOT WATER TEMPERATURE OR A LACK OF HOT WATER

This part of the troubleshooting chapter only applies if the heat pump is docked to the hot water heater or indoor module.

- Large hot water consumption.
 - Wait until the hot water has heated up.
- Incorrect hot water settings in indoor module or control module.
 - See the Installer Manual for the indoor module/control module.
- Clogged filterball.
 - Switch off the system. Check and clean the filterball.

LOW ROOM TEMPERATURE

- Closed thermostats in several rooms.
 - Set the thermostats to max in as many rooms as possible.
- Incorrect settings in indoor module or control module.
 - See the Installer Manual for the indoor module/control module.
- Air-filled radiators/underfloor heating coils.
 - Bleed the system.

HIGH ROOM TEMPERATURE

- Incorrect settings in indoor module or control module.
 - See the Installer Manual for the indoor module/control module.

ICE BUILD-UP IN THE FAN, GRILLE AND/OR FAN CONE

- Activate "fan de-icing" in the indoor module/control module. Alternatively "continuous fan de-icing" if the problem recurs.
- Check that the air flow across the evaporator is correct.

LARGE AMOUNT OF WATER BELOW S2125

- The accessory KVR is required.
- If KVR is installed, check that the water drainage can flow freely.

ACTIVE DEFROSTING IS TERMINATED

There are several possible reasons for an active defrosting to end:

- If the temperature of the evaporator sensor has reached its stop value (normal stop).
- When defrosting has gone on for longer than 15 minutes. This may be due to too little energy in the heat source, too strong a wind effect on the evaporator and/or that the sensor on the evaporator is not correct and therefore displays too low a temperature (at cold outdoor air).
- When the temperature on the return line sensor, BT3, falls below 10 °C.
- If the temperature of the evaporator (BP8) falls below its lowest permitted value. After failing to defrost ten times, S2125 must be checked. This is indicated by an alarm.
- The flow is less than the min. dimensioned flow at 100 % pump speed.

Alarm list

Alarm F-series	Alarms S-series	Alarm text on the display	Description existing alarm	May be due to
156 (80)	212	Low pressure alarm, cooling operation	5 repeated alarms for low low-pressure within 4 hours.	Poor flow. Significant wind effect.
224 (182)	233	Fan alarm in outd air heat pump	5 unsuccessful start attempt.	Fan blocked or not connected.
225 (8)	234	Flow fault	Return is hotter than flow.	Connection, supply line return line switched around,
228 (2)	236	Defrosting fault	10 failed consecutive defrostings.	System temperature and/or flow too low. Insufficient available system volume. Significant wind effect.
229 (4)	237	Short compressor oper time	Operation is stopped from the indoor section after less than 5 minutes.	Poor flow, poor heat transfer. Incorrect settings for heating and/or hot water.
230 (78)	238	High discharge	3 repeated alarms for high discharge within 4 hours.	Disruption in the refrigerant circuit. Lack of refrigerant.
232 (76)	240	Low evaporation	5 repeated alarms for low evaporation temperature within 4 hours.	Lack of refrigerant. Blocked expansion valve. Significant wind effect.
264 (203)	254	Communication fault to inverter	Alarm 203 from heat pump for 20 seconds.	Poor connection between PCB and inverter. Inverter unpowered or broken.
298 (92)	494	Preheat. failed, long run time	The inverter has tried to heat up the compressor, but has failed.	Defective inverter. Discharge sensor (BT14) has come loose from its mount.
300 (94)	495	Sensor BT14 or BP9 loose or defective	Sensor BT14 or BP9 has come loose or is otherwise defective.	The discharge sensor, BT14, or high pressure sensor, BP9, has come loose and is not giving correct measurement values.
341 (6)	291	Recurring safety defrosts	10 repeated defrostings according to the protection conditions.	Poor airflow, e.g. because of leaves, snow or ice. Lack of refrigerant.
344 (72)	294	Recurring low pressure	5 repeated low pressure alarm within 4 hours.	Lack of refrigerant. Blocked expansion valve. Disruption in the refrigerant circuit.
346 (74)	295	Recurring high pressure	5 repeated high pressure alarm within 4 hours.	Clogged particle filter, air or stoppage in the heating medium flow. Poor system pressure.
400 (207) 400 (209) 400 (211) 400 (213)	314	Undefined fault	Initiation fault, inverter. The inverter is not compatible Configuration file missing. Charge error configuration.	The inverter is not compatible
425 (108)	322	Press. switch or temp. alarm	2 repeated LP/HP/FQ alarms within 2.5 hours.	Poor heating medium flow. Lack of refrigerant. For FQ14: High temperature compressor peak. S2125-8, -12: 120 °C For FQ14.1: High temperature compressor peak. S2125-16, -20: 130 °C
427 (110)	323	Safety stop, inverter	Temporary fault in inverter, 2 times within 60 minutes.	Disruption in supply voltage.
429 (112)	324	Safety stop, inverter	Temporary fault in inverter, 3 times within 2 hours.	Disruption in supply voltage.

Alarm F-series	Alarms S-series	Alarm text on the display	Description existing alarm	May be due to
437 (120)	328	Mains disturbance	Temporary fault in inverter, 3 times within 2 hours or continuously for 1 hour.	Disruption in supply voltage. Incorrect connection in the inverter's terminal block X1.
439 (122)	329	Overheated inverter	The inverter has temporarily reached max working temperature, due to poor cooling 3 times within 2 hours or continuously for 1 hour.	Poor cooling of inverter. Defective inverter.
441 (124)	330	Safety stop, inverter	Current to inverter too high, 3 times within 2 hours or continuously for 1 hour.	Too high current to inverter. Low supply voltage.
443 (126)	331	Overheated inverter	The inverter has temporarily reached max working temperature, due to poor cooling 3 times within 2 hours or continuously for 1 hour.	Poor cooling of inverter. Defective inverter.
447 (130)	333	Phase drop	Compressor phase is missing, 3 times within 2 hours or continuously for 1 minute.	Disruption in supply voltage. Incorrectly connected compressor cable.
449 (132)	334	Failed compressor start	Compressor does not start when required, 3 times within 2 hours.	Defective inverter. Defective compressor.
453 (136)	336	High current load, compr.	The output current from the inverter to the compressor has been temporarily too high 3 times within 2 hours or continuously for 1 hour.	Disruption in supply voltage. Poor heating medium flow. Defective compressor.
455 (138)	337	High power load, compr.	The power output from the inverter has been too high 3 times within 2 hours or continuously for 1 hour.	Disruption in supply voltage. Poor heating medium flow. Defective compressor.
501 (184)	353	Failed start, no press. diff	The pressure difference between BP9 and BP8 has been too low at compressor start 3 times within 30 minutes.	Fault in pressure sensor BP8, BP9. The compressor does not compress the refrigerant sufficiently. Compressor breakdown.
503 (186)	354	Compressor speed too low	Compressor speed below lowest permitted speed.	The inverter's safety function reduces the speed outside of the compressor's working range.
523	418	Low defrosting flow	The flow is low. Check particle filter and pump.	Clogged particle filter. Defective circulation pump (charge pump). The pressure drop in the climate system is too large.
589 (216)	437	Incorrect PCB in heat pump.	The heat pump has the wrong base board.	The base board has been replaced with a base board that was not intended for this product.
740 (56)	541	Sens flt BT84 outd air ht pump	Sensor fault BT84.	Open-circuit or short-circuit on sensor input.
742 (52)	539	Sens flt BP9 outd air ht pump	Sensor fault BP9.	Open-circuit or short-circuit on sensor input.
744 (50)	538	Sens flt BP8 outd air ht pump	Sensor fault BP8.	Open-circuit or short-circuit on sensor input.
746 (46)	536	Sens flt BT28 outd air ht pump	Sensor fault BT28	Open-circuit or short-circuit on sensor input.
748 (44)	535	Sens flt BT17 outd air ht pump	Sensor fault BT17.	Open-circuit or short-circuit on sensor input.
750 (34)	530	Sens flt BT3 outd air ht pump	Sensor fault BT3.	Open-circuit or short-circuit on sensor input.
752 (42)	534	Sens flt BT16 outd air ht pump	Sensor fault BT16.	Open-circuit or short-circuit on sensor input.
754 (40)	533	Sens flt BT15 outd air ht pump	Sensor fault BT15.	Open-circuit or short-circuit on sensor input.
756 (38)	532	Sens flt BT14 outd air ht pump	Sensor fault BT14.	Open-circuit or short-circuit on sensor input.
758 (36)	531	Sens flt BT12 outd air ht pump	Sensor fault BT12.	Open-circuit or short-circuit on sensor input.

Alarm F-series	Alarms S-series	Alarm text on the display	Description existing alarm	May be due to
762 (90)	617	Temperature protection compressor activated	2 repeated FQ alarms within 2.5 hours.	Poor heating medium flow. Lack of refrigerant. S2125-16, -20: FQ14.1, High temperature compressor peak, 130 °C. FQ14.2, High temperature compressor intake, 75 °C.
765 (88)	616	Persistent high pressure switch alarm.	2 repeated HP alarms within 2.5 hours.	Poor heating medium flow. Lack of refrigerant.
767 (82)	615	Low pressure switch tripped	2 repeated LP alarms within 2.5 hours.	Poor heating medium flow. Lack of refrigerant.

Accessories

Detailed information about the accessories and complete accessories list available at nibe.eu.

Not all accessories are available on all markets.

CONDENSATION WATER PIPE KVR

Condensation water pipe with heating cable, different lengths.

KVR 11-10

1 metres
Part no. 067 823

KVR 11-30

3 metres
Part no. 067 824

KVR 11-60

6 metres
Part no. 067 825

Technical data

Dimensions

S2125-8, -12

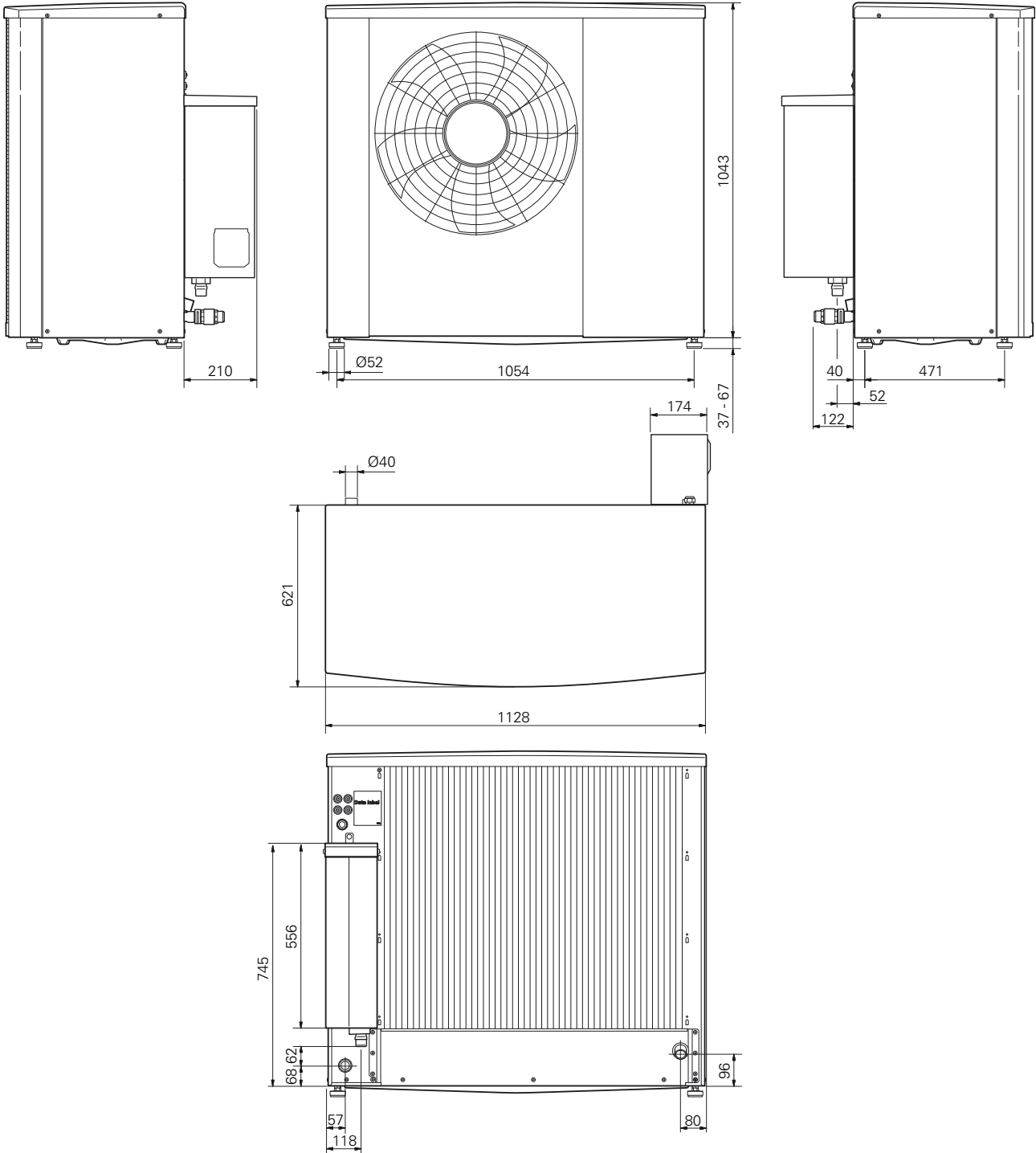

S2125-16, -20

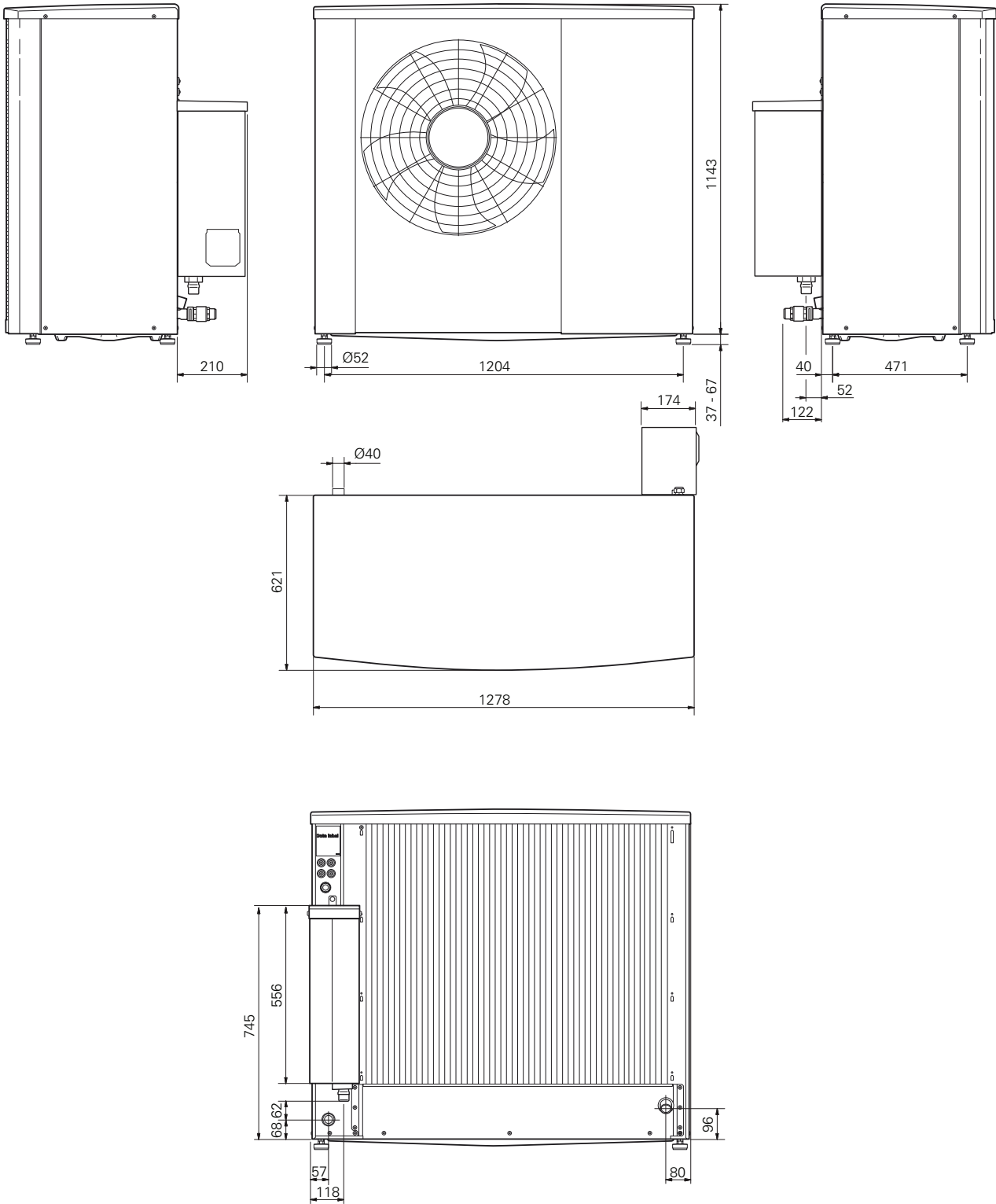

Sound levels

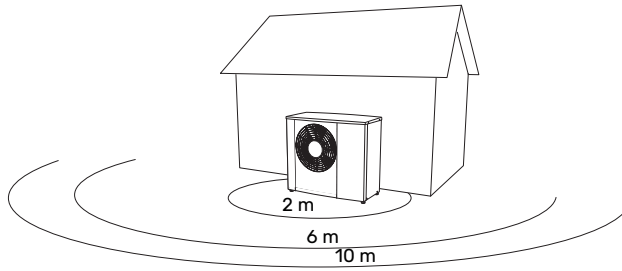

S2125 is usually placed next to a house wall, which gives a directed sound distribution that has to be taken into consideration. Accordingly, when setting up, you should always attempt to select the side that faces the least sound-sensitive neighbouring area.

The sound pressure levels are further affected by walls, bricks, differences in ground level, etc and should therefore only be seen as guide values.

		Sound power ¹	Sound pressure at distance (m) ²									
			1	2	3	4	5	6	7	8	9	10
S2125-8	Nominal sound value	49	44.0	38.0	34.5	32.0	30.0	28.5	27.0	26.0	25.0	24.0
	Max. sound value	55	50.0	44.0	40.5	38.0	36.0	34.5	33.0	32.0	31.0	30.0
	Max. sound value, silent mode	50	45.0	39.0	35.5	33.0	31.0	29.5	28.0	27.0	26.0	25.0
S2125-12	Nominal sound value	49	44.0	38.0	34.5	32.0	30.0	28.5	27.0	26.0	25.0	24.0
	Max. sound value	59	54.0	48.0	44.5	42.0	40.0	38.5	37.0	36.0	35.0	34.0
	Max. sound value, silent mode	54	49.0	43.0	39.5	37.0	35.0	33.5	32.0	31.0	30.0	29.0
S2125-16	Nominal sound value	55	50.0	44.0	40.5	38.0	36.0	34.5	33.0	32.0	31.0	30.0
	Max. sound value	60	55.0	49.0	45.5	43.0	41.0	39.5	38.0	37.0	36.0	35.0
	Max. sound value, silent mode	54	49.0	43.0	39.5	37.0	35.0	33.5	32.0	31.0	30.0	29.0
S2125-20	Nominal sound value	55	50.0	44.0	40.5	38.0	36.0	34.5	33.0	32.0	31.0	30.0
	Max. sound value	63	58.0	52.0	48.5	46.0	44.0	42.5	41.0	40.0	39.0	38.0
	Max. sound value, silent mode	55	50.0	44.0	40.5	38.0	36.0	34.5	33.0	32.0	31.0	30.0

¹ Sound power level, $L_w(A)$, according to EN12102

² Sound pressure calculated according to directivity factor $Q=4$

Technical specifications

WORKING RANGE, HEATING

S2125-8, -12

Supply temperature (°C)

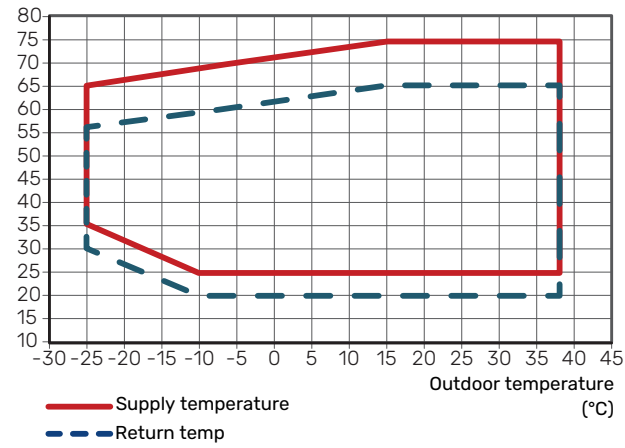

S2125-16, -20

Supply temperature (°C)

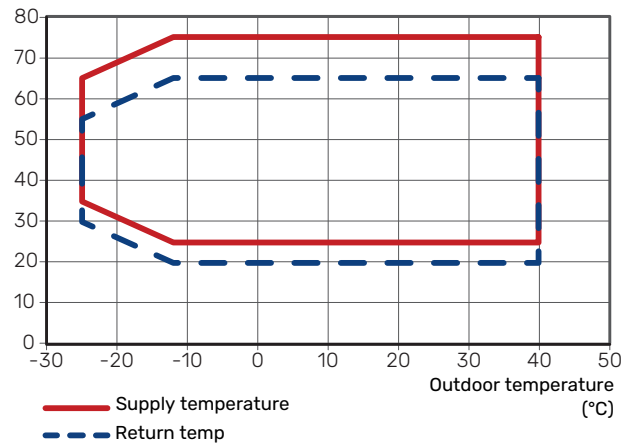

WORKING RANGE, COOLING

S2125-8, -12

Supply temperature (°C)

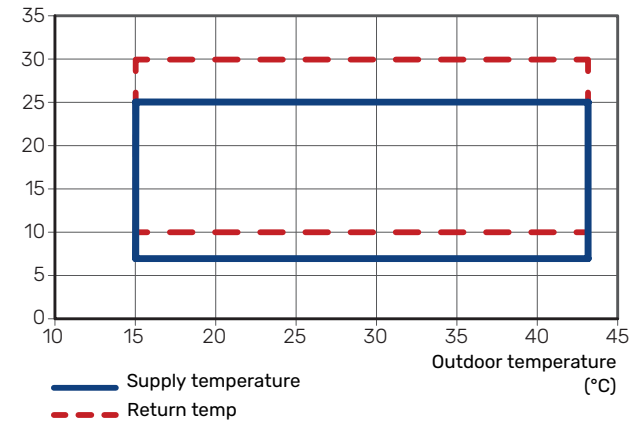

S2125-16, -20

Supply temperature (°C)

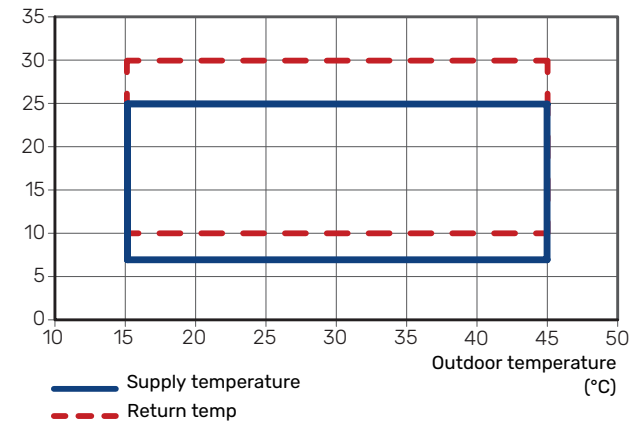

During shorter time it is allowed to have lower working temperatures on the water side, e.g. during start up.

POWER DURING HEATING OPERATION

Maximum and minimum capacity during continuous operation. Defrosting is not included.

S2125-8

Heating output (kW)

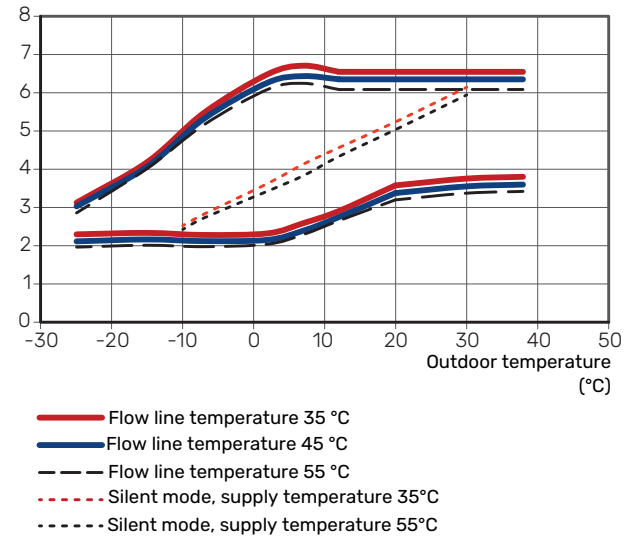

S2125-16

Heating output (kW)

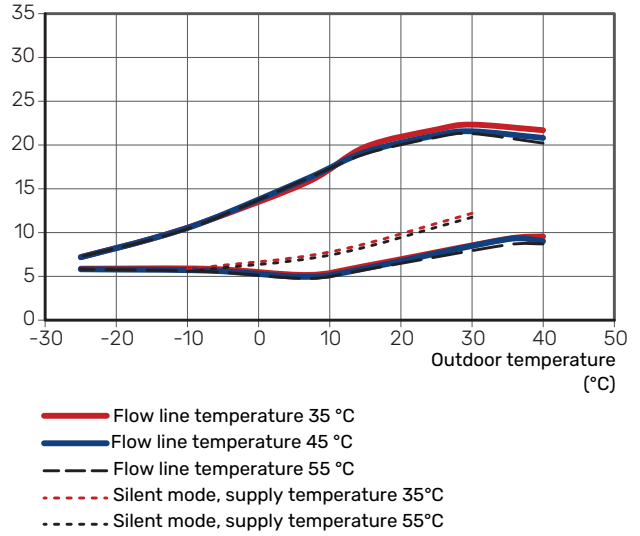

S2125-12

Heating output (kW)

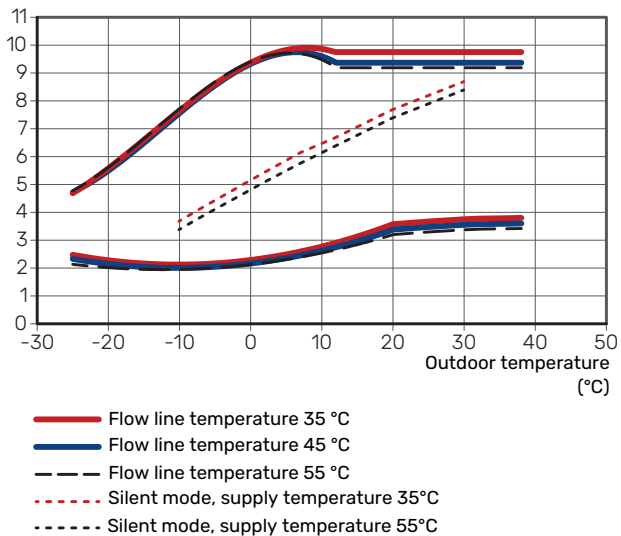

S2125-20

Heating output (kW)

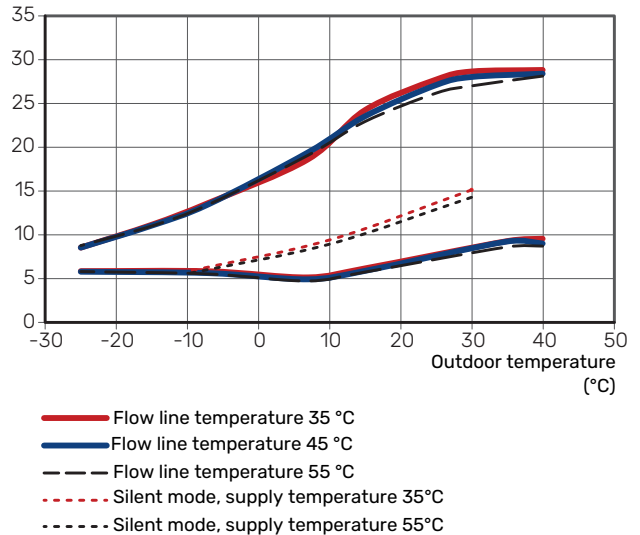

POWER DURING COOLING OPERATION

Maximum and minimum capacity during continuous operation.

S2125-8, -12

Cooling output (kW)

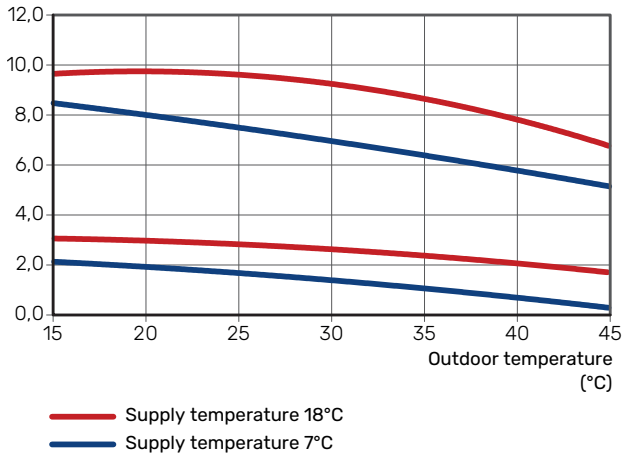

S2125-16, -20

Cooling output (kW)

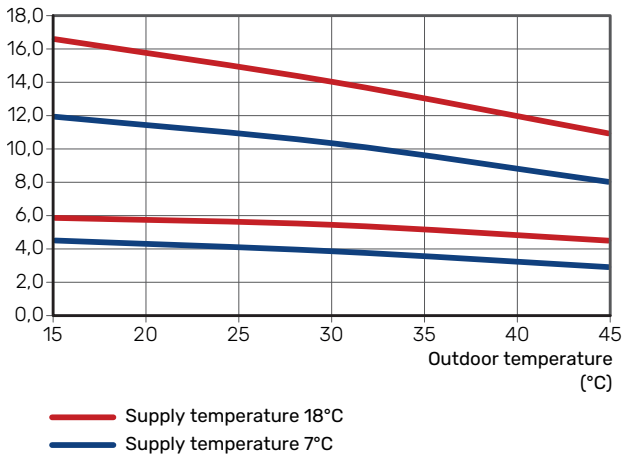

S2125		8	12	16	20
Voltage		1 x 230 V	1 x 230 V	1 x 230 V	1 x 230 V
Output data according to EN 14 511, partial load¹					
Heating	-7 / 35 °C	4.72 / 1.72 / 2.74	7.23 / 2.73 / 2.65	10.31 / 3.72 / 2.77	12.03 / 4.56 / 2.64
Capacity / power input / COP (kW/kW/-) at nominal flow	2 / 35 °C	3.20 / 0.72 / 4.44	3.67 / 0.85 / 4.32	6.58 / 1.41 / 4.66	7.38 / 1.59 / 4.63
Outdoor temp. / Supply temp.	2 / 45 °C	2.95 / 0.87 / 3.39	3.46 / 1.02 / 3.40	6.65 / 1.81 / 3.68	7.44 / 2.02 / 3.67
	7 / 35 °C	3.15 / 0.61 / 5.16	3.67 / 0.70 / 5.24	5.10 / 0.92 / 5.55	5.10 / 0.92 / 5.55
	7 / 45 °C	2.97 / 0.76 / 3.90	3.35 / 0.85 / 3.94	4.85 / 1.18 / 4.12	4.85 / 1.18 / 4.12
Cooling	35 / 7 °C	6.69 / 2.41 / 2.77	6.69 / 2.41 / 2.77	9.74 / 3.16 / 3.08	9.74 / 3.16 / 3.08
Capacity / power input / EER (kW/kW/-) at maximum flow	35 / 18 °C	8.68 / 2.60 / 3.34	8.68 / 2.60 / 3.34	13.62 / 3.46 / 3.93	13.62 / 3.46 / 3.93
Outdoor temp. / Supply temp.					
Maximum capacity					
Maximum capacity, heating, at A2W55 with / without defrosting	kW	5.22 / 6.79	7.54 / 9.63	12.42 / 14.44	13.89 / 16.48
Maximum capacity, heating, at A-7W35 without defrosting	kW	5.52	8.34	11.42	13.64
SCOP according to EN 14825					
Nominal heat output (P _{designh}) average climate 35 °C / 55 °C (Europe)	kW	5.33 / 5.30	6.80 / 7.60	11.00 / 11.00	11.00 / 11.00
Nominal heat output (P _{designh}) cold climate 35 °C / 55 °C	kW	5.40 / 5.20	8.40 / 8.40	13.00 / 14.00	13.00 / 14.00
Nominal heat output (P _{designh}) warm climate 35 °C / 55 °C	kW	5.50 / 5.20	7.00 / 7.45	13.00 / 13.00	13.00 / 13.00
SCOP average climate, 35 °C / 55 °C (Europe)		5.00 / 3.70	5.00 / 3.80	5.33 / 4.08	5.30 / 4.08
SCOP cold climate, 35 °C / 55 °C		4.10 / 3.20	4.20 / 3.40	4.47 / 3.59	4.60 / 3.69
SCOP warm climate, 35 °C / 55 °C		6.30 / 4.50	6.30 / 4.60	5.98 / 4.79	6.29 / 4.78
Energy rating, average climate²					
The product's room heating efficiency class 35 °C / 55 °C ³		A+++ / A++	A+++ / A+++	A+++ / A+++	A+++ / A+++
The system's room heating efficiency class 35 °C / 55 °C ⁴		A+++ / A+++			
Electrical data					
Rated voltage		230 V – 50 Hz	230 V – 50 Hz	230 V – 50 Hz	230 V – 50 Hz
Rated current, heat pump	A _{rms}	13	19.6	30	33
Max. power, fan	W	30	50	43	69
Fuse	A _{rms}	16	20	35	35
Enclosure class		IP24			
Refrigerant circuit					
Type of refrigerant		R290			
GWP refrigerant		0.02			
Filling amount	kg	0.8	0.8	1.15	1.15
Type of compressor		Rotary compressor	Rotary compressor	Scroll compressor	Scroll compressor
CO ₂ -equivalent (The cooling circuit is hermetically sealed.)	kg	0.016	0.016	0.023	0.023
Cut-out value pressure switch HP (BP1)	MPa (bar)	3.15 (31.5)			
Difference pressostat HP	MPa (bar)	0.7 (7.0)			
Cut-out value pressure switch LP (BP2)	MPa (bar)	0.03 (0.3)	0.03 (0.3)	0.02 (0.2)	0.02 (0.2)
Difference pressostat LP	MPa (bar)	0.07 (0.7)	0.07 (0.7)	0.05 (0.5)	0.05 (0.5)
Airflow					
Max airflow	m ³ /h	2,400	2,950	3,100	3,800
Working area					
Min./max. air temperature, heating	°C	-25 / 38	-25 / 38	-25 / 40	-25 / 40
Min./max. air temperature, cooling	°C	15 / 43	15 / 43	15 / 45	15 / 45
Defrosting system		Reverse cycle			
Heating medium circuit					
Max system pressure heating medium	MPa (bar)	0.45 (4.5)			
Cut-off pressure, heating medium	MPa (bar)	0.25 (2.5)			
Recommended flow interval, heating operation	l/s	0.08 – 0.32	0.12 – 0.48	0.16 – 0.64	0.20 – 0.80
Min. design flow, defrosting (100% pump speed)	l/s	0.32	0.32	0.38	0.48
Min/max supply temperature for heating medium (HM) during continuous operation	°C	25 / 75			
Connection heating medium S2125		G1" external thread			
Connection heating medium flex pipe		G1" external thread	G1" external thread	G1¼" external thread	G1¼" external thread
Min. recommended pipe dimension (system)	DN (mm)	25 (28)	25 (28)	25 (28)	32 (35)
Dimensions and weight					
Width	mm	1,128	1,128	1,278	1,278

S2125		8	12	16	20
Depth	mm	831			
Height	mm	1,080	1,080	1,180	1,180
Weight	kg	163	163	196	196
Miscellaneous					
Part no.		064 220	064 218	064 216	064 214
EPREL		108 98 05	108 97 19	214 67 41	214 67 26

- 1 Power statements including defrosting according to EN 14511 at heating medium supply corresponding to DT=5 K at 7 / 45.
- 2 The reported efficiency of the package also takes the controller into account. If an external supplementary boiler or solar heating is added to the package, the overall efficiency of the package should be recalculated.
- 3 Scale for the product's efficiency class room heating: A+++ to D. Control module model SMO S.
- 4 Scale for the system's efficiency class room heating: A+++ to G. Reported efficiency for the system takes the product's temperature regulator into account. Control module model SMO S.

S2125		8	12	16	20
Voltage		3 x 400 V	3 x 400 V	3 x 400 V	3 x 400 V
Output data according to EN 14 511, partial load¹					
Heating	-7 / 35 °C	4.72 / 1.72 / 2.74	7.23 / 2.73 / 2.65	10.31 / 3.72 / 2.77	12.03 / 4.56 / 2.64
Capacity / power input / COP (kW/kW/-) at nominal flow	2 / 35 °C	3.20 / 0.72 / 4.44	3.67 / 0.85 / 4.32	6.58 / 1.41 / 4.66	7.38 / 1.59 / 4.63
Outdoor temp: / Supply temp.	2 / 45 °C	2.95 / 0.87 / 3.39	3.46 / 1.02 / 3.40	6.65 / 1.81 / 3.68	7.44 / 2.02 / 3.67
	7 / 35 °C	3.15 / 0.61 / 5.16	3.67 / 0.70 / 5.24	5.10 / 0.92 / 5.55	5.10 / 0.92 / 5.55
	7 / 45 °C	2.97 / 0.76 / 3.90	3.35 / 0.85 / 3.94	4.85 / 1.18 / 4.12	4.85 / 1.18 / 4.12
Cooling	35 / 7 °C	6.69 / 2.41 / 2.77	6.69 / 2.41 / 2.77	9.74 / 3.16 / 3.08	9.74 / 3.16 / 3.08
Capacity / power input / EER (kW/kW/-) at maximum flow	35 / 18 °C	8.68 / 2.60 / 3.34	8.68 / 2.60 / 3.34	13.62 / 3.46 / 3.93	13.62 / 3.46 / 3.93
Outdoor temp: / Supply temp.					
Maximum capacity					
Maximum capacity, heating, at A2W55 with / without defrosting	kW	5.22 / 6.79	7.54 / 9.63	12.42 / 14.44	13.89 / 16.48
Maximum capacity, heating, at A-7W35 without defrosting	kW	5.52	8.34	11.42	13.64
SCOP according to EN 14825					
Nominal heat output (P _{designh}) average climate 35 °C / 55 °C (Europe)	kW	5.33 / 5.30	6.80 / 7.60	11.00 / 11.00	11.00 / 11.00
Nominal heat output (P _{designh}) cold climate 35 °C / 55 °C	kW	5.40 / 5.20	8.40 / 8.40	13.00 / 14.00	13.00 / 14.00
Nominal heat output (P _{designh}) warm climate 35 °C / 55 °C	kW	5.50 / 5.20	7.00 / 7.45	13.00 / 13.00	13.00 / 13.00
SCOP average climate, 35 °C / 55 °C (Europe)		5.00 / 3.70	5.00 / 3.80	5.33 / 4.08	5.30 / 4.08
SCOP cold climate, 35 °C / 55 °C		4.10 / 3.20	4.20 / 3.40	4.47 / 3.59	4.60 / 3.69
SCOP warm climate, 35 °C / 55 °C		6.30 / 4.50	6.30 / 4.60	5.98 / 4.79	6.29 / 4.78
Energy rating, average climate²					
The product's room heating efficiency class 35 °C / 55 °C ³		A+++ / A++	A+++ / A+++	A+++ / A+++	A+++ / A+++
The system's room heating efficiency class 35 °C / 55 °C ⁴		A+++ / A+++			
Electrical data					
Rated voltage		400 V 3N - 50 Hz	400 V 3N - 50 Hz	400 V 3N - 50 Hz	400 V 3N - 50 Hz
Rated current, heat pump	A _{rms}	4.6	6.9	10	11.5
Max. power, fan	W	30	50	43	69
Fuse	A _{rms}	6	10	10	16
Enclosure class		IP24			
Refrigerant circuit					
Type of refrigerant		R290			
GWP refrigerant		0,02			
Filling amount	kg	0.8	0.8	1.15	1.15
Type of compressor		Rotary compressor	Rotary compressor	Scroll compressor	Scroll compressor
CO ₂ -equivalent (The cooling circuit is hermetically sealed.)	kg	0.016	0.016	0.023	0.023
Cut-out value pressure switch HP (BP1)	MPa (bar)	3.15 (31.5)			
Difference pressostat HP	MPa (bar)	0.7 (7.0)			
Cut-out value pressure switch LP (BP2)	MPa (bar)	0.03 (0.3)	0.03 (0.3)	0.02 (0.2)	0.02 (0.2)
Difference pressostat LP	MPa (bar)	0.07 (0.7)	0.07 (0.7)	0.05 (0.5)	0.05 (0.5)
Airflow					
Max airflow	m ³ /h	2,400	2,950	3,100	3,800
Working area					
Min./max. air temperature, heating	°C	-25 / 38	-25 / 38	-25 / 40	-25 / 40
Min./max. air temperature, cooling	°C	15 / 43	15 / 43	15 / 45	15 / 45
Defrosting system		Reverse cycle			
Heating medium circuit					
Max system pressure heating medium	MPa (bar)	0.45 (4.5)			
Cut-off pressure, heating medium	MPa (bar)	0.25 (2.5)			
Recommended flow interval, heating operation	l/s	0.08 - 0.32	0.12 - 0.48	0.16 - 0.64	0.20 - 0.80
Min. design flow, defrosting (100% pump speed)	l/s	0.32	0.32	0.38	0.48
Min./max. HM temp, continuous operation	°C	25 / 75			
Connection heating medium S2125		G1" external thread			
Connection heating medium flex pipe		G1" external thread	G1" external thread	G1¼" external thread	G1¼" external thread
Min. recommended pipe dimension (system)	DN (mm)	25 (28)	25 (28)	25 (28)	32 (35)
Dimensions and weight					
Width	mm	1,128	1,128	1,278	1,278
Depth	mm	831			

S2125		8	12	16	20
Height	mm	1,080	1,080	1,180	1,180
Weight	kg	179	179	215	215
Miscellaneous					
Part no.		064 219	064 217	064 215	064 213
EPREL		213 97 57	214 04 04	214 67 41	214 67 26

- 1 Power statements including defrosting according to EN 14511 at heating medium supply corresponding to DT=5 K at 7 / 45.
- 2 The reported efficiency of the package also takes the controller into account. If an external supplementary boiler or solar heating is added to the package, the overall efficiency of the package should be recalculated.
- 3 Scale for the product's efficiency class room heating: A+++ to D. Control module model SMO S.
- 4 Scale for the system's efficiency class room heating: A+++ to G. Reported efficiency for the system takes the product's temperature regulator into account. Control module model SMO S.

Energy labelling

INFORMATION SHEET

Supplier		NIBE			
Model		S2125-8 1x230 V	S2125-12 1x230 V	S2125-16 1x230 V	S2125-20 1x230 V
Temperature application	°C	35 / 55	35 / 55	35 / 55	35 / 55
Seasonal space heating energy efficiency class, average climate		A+++ / A++	A+++ / A+++	A+++ / A+++	A+++ / A+++
Rated heat output (P _{design,h}), average climate	kW	5.3 / 5.3	6.8 / 7.6	11.0 / 11.0	11.0 / 11.0
Annual energy consumption space heating, average climate	kWh	2,196 / 2,939	2,835 / 4,102	4,264 / 5,571	4,288 / 5,571
Seasonal space heating energy efficiency, average climate	%	196 / 146	195 / 150	210 / 160	209 / 160
Sound power level L _{WA} indoors	dB	-	-	-	-
Rated heat output (P _{design,h}), cold climate	kW	5.4 / 5.2	8.4 / 8.4	13.0 / 14.0	13.0 / 14.0
Rated heat output (P _{design,h}), warm climate	kW	5.5 / 5.2	7.0 / 7.5	13.0 / 13.0	13.0 / 13.0
Annual energy consumption space heating, cold climate	kWh	3,238 / 4,055	4,990 / 6,189	7,170 / 9,638	6,960 / 9,361
Annual energy consumption space heating, warm climate	kWh	1,161 / 1,570	1,494 / 2,180	2,903 / 3,627	2,759 / 3,631
Seasonal space heating energy efficiency, cold climate	%	161 / 123	163 / 131	176 / 140	181 / 144
Seasonal space heating energy efficiency, warm climate	%	250 / 174	247 / 180	236 / 189	249 / 188
Sound power level L _{WA} outdoors	dB	49	49	55	55

Supplier		NIBE			
Model		S2125-8 3x400 V	S2125-12 3x400 V	S2125-16 3x400 V	S2125-20 3x400 V
Temperature application	°C	35 / 55	35 / 55	35 / 55	35 / 55
Seasonal space heating energy efficiency class, average climate		A+++ / A++	A+++ / A+++	A+++ / A+++	A+++ / A+++
Rated heat output (P _{design,h}), average climate	kW	5.3 / 5.3	6.8 / 7.6	11.0 / 11.0	11.0 / 11.0
Annual energy consumption space heating, average climate	kWh	2,196 / 2,939	2,835 / 4,102	4,264 / 5,571	4288 / 5571
Seasonal space heating energy efficiency, average climate	%	196 / 146	195 / 150	210 / 160	209 / 160
Sound power level L _{WA} indoors	dB	-	-	-	-
Rated heat output (P _{design,h}), cold climate	kW	5.4 / 5.2	8.4 / 8.4	13.0 / 14.0	13.0 / 14.0
Rated heat output (P _{design,h}), warm climate	kW	5.5 / 5.2	7.0 / 7.5	13.0 / 13.0	13.0 / 13.0
Annual energy consumption space heating, cold climate	kWh	3,238 / 4,055	4,990 / 6,189	7170 / 9638	6960 / 9361
Annual energy consumption space heating, warm climate	kWh	1,161 / 1,570	1,494 / 2,180	2903 / 3627	2759 / 3631
Seasonal space heating energy efficiency, cold climate	%	161 / 123	163 / 131	176 / 140	181 / 144
Seasonal space heating energy efficiency, warm climate	%	250 / 174	247 / 180	236 / 189	249 / 188
Sound power level L _{WA} outdoors	dB	49	49	55	55

DATA FOR ENERGY EFFICIENCY OF THE PACKAGE

Model		S2125-8 1x230 V	S2125-12 1x230 V	S2125-16 1x230 V	S2125-20 1x230 V
Control module model		SMO S	SMO S	SMO S	SMO S
Temperature application	°C	35 / 55	35 / 55	35 / 55	35 / 55
Controller, class		VI			
Controller, contribution to efficiency	%	4.0			
Seasonal space heating energy efficiency of the package, average climate	%	200 / 150	199 / 154	214 / 164	213 / 164
Seasonal space heating energy efficiency class of the package, average climate		A+++ / A+++	A+++ / A+++	A+++ / A+++	A+++ / A+++
Seasonal space heating energy efficiency of the package, cold climate	%	165 / 127	167 / 135	180 / 144	185 / 148
Seasonal space heating energy efficiency of the package, warm climate	%	254 / 178	251 / 184	240 / 193	253 / 192

Model		S2125-8 3x400 V	S2125-12 3x400 V	S2125-16 3x400 V	S2125-20 3x400 V
Control module model		SMO S	SMO S	SMO S	SMO S
Temperature application	°C	35 / 55	35 / 55	35 / 55	35 / 55
Controller, class		VI			
Controller, contribution to efficiency	%	4.0			
Seasonal space heating energy efficiency of the package, average climate	%	200 / 150	199 / 154	214 / 164	213 / 164
Seasonal space heating energy efficiency class of the package, average climate		A+++ / A+++	A+++ / A+++	A+++ / A+++	A+++ / A+++
Seasonal space heating energy efficiency of the package, cold climate	%	165 / 127	167 / 135	180 / 144	185 / 148
Seasonal space heating energy efficiency of the package, warm climate	%	254 / 178	251 / 184	240 / 193	253 / 192

The reported efficiency of the package also takes the controller into account. If an external supplementary boiler or solar heating is added to the package, the overall efficiency of the package should be recalculated.

TECHNICAL DOCUMENTATION

Model		S2125-8 1x230 V					
Type of heat pump	<input checked="" type="checkbox"/> Air-water <input type="checkbox"/> Exhaust-water <input type="checkbox"/> Brine-water <input type="checkbox"/> Water-water						
Low-temperature heat pump	<input type="checkbox"/> Yes <input checked="" type="checkbox"/> No						
Integrated immersion heater for additional heat	<input type="checkbox"/> Yes <input checked="" type="checkbox"/> No						
Heat pump combination heater	<input type="checkbox"/> Yes <input checked="" type="checkbox"/> No						
Climate	<input checked="" type="checkbox"/> Average <input type="checkbox"/> Cold <input type="checkbox"/> Warm						
Temperature application	<input checked="" type="checkbox"/> Medium (55°C) <input type="checkbox"/> Low (35°C)						
Applied standards	EN14825 / EN14511 / EN12102						
Rated heat output	Prated	5.3	kW	Seasonal space heating energy efficiency	η_s	146	%
Declared capacity for space heating at part load and at outdoor temperature T_j				Declared coefficient of performance for space heating at part load and at outdoor temperature T_j			
$T_j = -7\text{ °C}$	Pdh	4.6	kW	$T_j = -7\text{ °C}$	COPd	2.19	-
$T_j = +2\text{ °C}$	Pdh	2.8	kW	$T_j = +2\text{ °C}$	COPd	3.77	-
$T_j = +7\text{ °C}$	Pdh	2.1	kW	$T_j = +7\text{ °C}$	COPd	4.75	-
$T_j = +12\text{ °C}$	Pdh	2.3	kW	$T_j = +12\text{ °C}$	COPd	5.70	-
$T_j = \text{biv}$	Pdh	4.6	kW	$T_j = \text{biv}$	COPd	2.19	-
$T_j = \text{TOL}$	Pdh	4.8	kW	$T_j = \text{TOL}$	COPd	2.21	-
$T_j = -15\text{ °C}$ (if TOL < -20 °C)	Pdh		kW	$T_j = -15\text{ °C}$ (if TOL < -20 °C)	COPd		-
Bivalent temperature	T_{biv}	-10	°C	Min. outdoor air temperature	TOL	-10	°C
Cycling interval capacity	P _{cy}		kW	Cycling interval efficiency	COP _{cy}		-
Degradation coefficient	Cdh	0.97	-	Max supply temperature	WTOL	65	°C
Power consumption in modes other than active mode				Additional heat			
Off mode	P _{OFF}	0.008	kW	Rated heat output	P _{sup}	0.0	kW
Thermostat-off mode	P _{TO}	0.013	kW				
Standby mode	P _{SB}	0.011	kW	Type of energy input	Electric		
Crankcase heater mode	P _{CK}	0.005	kW				
<i>Other items</i>							
Capacity control	Variable			Rated airflow (air-water)		2,400	m ³ /h
Sound power level, indoors/outdoors	L _{WA}	- / 49	dB	Nominal heating medium flow			m ³ /h
Annual energy consumption	Q _{HE}	2,939	kWh	Brine flow brine-water or water-water heat pumps			m ³ /h
Contact information	NIBE Energy Systems - Box 14 - Hannabadsvägen 5 - 285 21 Markaryd - Sweden						

Model		S2125-12 1x230 V							
Type of heat pump	<input checked="" type="checkbox"/> Air-water <input type="checkbox"/> Exhaust-water <input type="checkbox"/> Brine-water <input type="checkbox"/> Water-water								
Low-temperature heat pump	<input type="checkbox"/> Yes <input checked="" type="checkbox"/> No								
Integrated immersion heater for additional heat	<input type="checkbox"/> Yes <input checked="" type="checkbox"/> No								
Heat pump combination heater	<input type="checkbox"/> Yes <input checked="" type="checkbox"/> No								
Climate	<input checked="" type="checkbox"/> Average <input type="checkbox"/> Cold <input type="checkbox"/> Warm								
Temperature application	<input checked="" type="checkbox"/> Medium (55°C) <input type="checkbox"/> Low (35°C)								
Applied standards	EN14825 / EN14511 / EN12102								
Rated heat output	Prated	7,6	kW	Seasonal space heating energy efficiency	η_s	150	%		
Declared capacity for space heating at part load and at outdoor temperature T_j				Declared coefficient of performance for space heating at part load and at outdoor temperature T_j					
$T_j = -7\text{ °C}$	Pdh	6.7	kW	$T_j = -7\text{ °C}$	COPd	2.17	-		
$T_j = +2\text{ °C}$	Pdh	4.2	kW	$T_j = +2\text{ °C}$	COPd	3.83	-		
$T_j = +7\text{ °C}$	Pdh	2.7	kW	$T_j = +7\text{ °C}$	COPd	5.12	-		
$T_j = +12\text{ °C}$	Pdh	2.4	kW	$T_j = +12\text{ °C}$	COPd	5.87	-		
$T_j = \text{biv}$	Pdh	7.6	kW	$T_j = \text{biv}$	COPd	2.11	-		
$T_j = \text{TOL}$	Pdh	7.6	kW	$T_j = \text{TOL}$	COPd	2.11	-		
$T_j = -15\text{ °C}$ (if TOL < -20 °C)	Pdh		kW	$T_j = -15\text{ °C}$ (if TOL < -20 °C)	COPd		-		
Bivalent temperature	T_{biv}	-10	°C	Min. outdoor air temperature	TOL	-10	°C		
Cycling interval capacity	P _{cy}		kW	Cycling interval efficiency	COP _{cy}		-		
Degradation coefficient	Cdh	0.97	-	Max supply temperature	WTOL	65	°C		
Power consumption in modes other than active mode				Additional heat					
Off mode	P _{OFF}	0.008	kW	Rated heat output	P _{sup}	0	kW		
Thermostat-off mode	P _{TO}	0.013	kW						
Standby mode	P _{SB}	0.011	kW	Type of energy input	Electric				
Crankcase heater mode	P _{CK}	0.005	kW						
Other items									
Capacity control	Variable			Rated airflow (air-water)		2,900	m ³ /h		
Sound power level, indoors/outdoors	L _{WA}	- / 49	dB	Nominal heating medium flow			m ³ /h		
Annual energy consumption	Q _{HE}	4,102	kWh	Brine flow brine-water or water-water heat pumps			m ³ /h		
Contact information	NIBE Energy Systems – Box 14 – Hannabadsvägen 5 – 285 21 Markaryd – Sweden								

Model		S2125-16 1x230 V							
Type of heat pump	<input checked="" type="checkbox"/> Air-water <input type="checkbox"/> Exhaust-water <input type="checkbox"/> Brine-water <input type="checkbox"/> Water-water								
Low-temperature heat pump	<input type="checkbox"/> Yes <input checked="" type="checkbox"/> No								
Integrated immersion heater for additional heat	<input type="checkbox"/> Yes <input checked="" type="checkbox"/> No								
Heat pump combination heater	<input type="checkbox"/> Yes <input checked="" type="checkbox"/> No								
Climate	<input checked="" type="checkbox"/> Average <input type="checkbox"/> Cold <input type="checkbox"/> Warm								
Temperature application	<input checked="" type="checkbox"/> Medium (55°C) <input type="checkbox"/> Low (35°C)								
Applied standards	EN14825 / EN14511 / EN12102								
Rated heat output	Prated	11.0	kW	Seasonal space heating energy efficiency	η_s	160	%		
Declared capacity for space heating at part load and at outdoor temperature T_j				Declared coefficient of performance for space heating at part load and at outdoor temperature T_j					
$T_j = -7\text{ °C}$	Pdh	9.6	kW	$T_j = -7\text{ °C}$	COPd	2.49	-		
$T_j = +2\text{ °C}$	Pdh	5.8	kW	$T_j = +2\text{ °C}$	COPd	4.07	-		
$T_j = +7\text{ °C}$	Pdh	5.1	kW	$T_j = +7\text{ °C}$	COPd	5.25	-		
$T_j = +12\text{ °C}$	Pdh	5.7	kW	$T_j = +12\text{ °C}$	COPd	6.25	-		
$T_j = \text{biv}$	Pdh	10.5	kW	$T_j = \text{biv}$	COPd	2.16	-		
$T_j = \text{TOL}$	Pdh	10.5	kW	$T_j = \text{TOL}$	COPd	2.16	-		
$T_j = -15\text{ °C}$ (if TOL < -20 °C)	Pdh		kW	$T_j = -15\text{ °C}$ (if TOL < -20 °C)	COPd		-		
Bivalent temperature	T_{biv}	-10	°C	Min. outdoor air temperature	TOL	-10	°C		
Cycling interval capacity	P _{cy}		kW	Cycling interval efficiency	COP _{cy}		-		
Degradation coefficient	Cdh	0.98	-	Max supply temperature	WTOL	65	°C		
Power consumption in modes other than active mode				Additional heat					
Off mode	P _{OFF}	0.007	kW	Rated heat output	P _{sup}	0.0	kW		
Thermostat-off mode	P _{TO}	0.014	kW						
Standby mode	P _{SB}	0.010	kW	Type of energy input	Electric				
Crankcase heater mode	P _{CK}	0.011	kW						
Other items									
Capacity control	Variable			Rated airflow (air-water)		2,900	m ³ /h		
Sound power level, indoors/outdoors	L _{WA}	- / 55	dB	Nominal heating medium flow			m ³ /h		
Annual energy consumption	Q _{HE}	5,571	kWh	Brine flow brine-water or water-water heat pumps			m ³ /h		
Contact information	NIBE Energy Systems – Box 14 – Hannabadsvägen 5 – 285 21 Markaryd – Sweden								

Model		S2125-20 1x230 V							
Type of heat pump	<input checked="" type="checkbox"/> Air-water <input type="checkbox"/> Exhaust-water <input type="checkbox"/> Brine-water <input type="checkbox"/> Water-water								
Low-temperature heat pump	<input type="checkbox"/> Yes <input checked="" type="checkbox"/> No								
Integrated immersion heater for additional heat	<input type="checkbox"/> Yes <input checked="" type="checkbox"/> No								
Heat pump combination heater	<input type="checkbox"/> Yes <input checked="" type="checkbox"/> No								
Climate	<input checked="" type="checkbox"/> Average <input type="checkbox"/> Cold <input type="checkbox"/> Warm								
Temperature application	<input checked="" type="checkbox"/> Medium (55°C) <input type="checkbox"/> Low (35°C)								
Applied standards	EN14825 / EN14511 / EN12102								
Rated heat output	Prated	11.0	kW	Seasonal space heating energy efficiency	η_s	160	%		
Declared capacity for space heating at part load and at outdoor temperature T_j				Declared coefficient of performance for space heating at part load and at outdoor temperature T_j					
$T_j = -7\text{ °C}$	Pdh	9.6	kW	$T_j = -7\text{ °C}$	COPd	2.49	-		
$T_j = +2\text{ °C}$	Pdh	5.8	kW	$T_j = +2\text{ °C}$	COPd	4.07	-		
$T_j = +7\text{ °C}$	Pdh	5.1	kW	$T_j = +7\text{ °C}$	COPd	5.25	-		
$T_j = +12\text{ °C}$	Pdh	5.7	kW	$T_j = +12\text{ °C}$	COPd	6.25	-		
$T_j = \text{biv}$	Pdh	10.5	kW	$T_j = \text{biv}$	COPd	2.16	-		
$T_j = \text{TOL}$	Pdh	10.5	kW	$T_j = \text{TOL}$	COPd	2.16	-		
$T_j = -15\text{ °C}$ (if TOL < -20 °C)	Pdh		kW	$T_j = -15\text{ °C}$ (if TOL < -20 °C)	COPd		-		
Bivalent temperature	T_{biv}	-10	°C	Min. outdoor air temperature	TOL	-10	°C		
Cycling interval capacity	P _{cy}		kW	Cycling interval efficiency	COP _{cy}		-		
Degradation coefficient	Cdh	0.98	-	Max supply temperature	WTOL	65	°C		
Power consumption in modes other than active mode				Additional heat					
Off mode	P _{OFF}	0.007	kW	Rated heat output	P _{sup}	0.0	kW		
Thermostat-off mode	P _{TO}	0.014	kW						
Standby mode	P _{SB}	0.010	kW	Type of energy input	Electric				
Crankcase heater mode	P _{CK}	0.011	kW						
Other items									
Capacity control	Variable			Rated airflow (air-water)		2,900	m ³ /h		
Sound power level, indoors/outdoors	L _{WA}	- / 55	dB	Nominal heating medium flow			m ³ /h		
Annual energy consumption	Q _{HE}	5,571	kWh	Brine flow brine-water or water-water heat pumps			m ³ /h		
Contact information	NIBE Energy Systems – Box 14 – Hannabadsvägen 5 – 285 21 Markaryd – Sweden								

Model		S2125-8 3x400 V							
Type of heat pump	<input checked="" type="checkbox"/> Air-water <input type="checkbox"/> Exhaust-water <input type="checkbox"/> Brine-water <input type="checkbox"/> Water-water								
Low-temperature heat pump	<input type="checkbox"/> Yes <input checked="" type="checkbox"/> No								
Integrated immersion heater for additional heat	<input type="checkbox"/> Yes <input checked="" type="checkbox"/> No								
Heat pump combination heater	<input type="checkbox"/> Yes <input checked="" type="checkbox"/> No								
Climate	<input checked="" type="checkbox"/> Average <input type="checkbox"/> Cold <input type="checkbox"/> Warm								
Temperature application	<input checked="" type="checkbox"/> Medium (55°C) <input type="checkbox"/> Low (35°C)								
Applied standards	EN14825 / EN14511 / EN12102								
Rated heat output	Prated	5.3	kW	Seasonal space heating energy efficiency	η_s	146	%		
Declared capacity for space heating at part load and at outdoor temperature T_j				Declared coefficient of performance for space heating at part load and at outdoor temperature T_j					
$T_j = -7\text{ °C}$	Pdh	4.6	kW	$T_j = -7\text{ °C}$	COPd	2.19	-		
$T_j = +2\text{ °C}$	Pdh	2.8	kW	$T_j = +2\text{ °C}$	COPd	3.77	-		
$T_j = +7\text{ °C}$	Pdh	2.1	kW	$T_j = +7\text{ °C}$	COPd	4.75	-		
$T_j = +12\text{ °C}$	Pdh	2.3	kW	$T_j = +12\text{ °C}$	COPd	5.70	-		
$T_j = \text{biv}$	Pdh	4.6	kW	$T_j = \text{biv}$	COPd	2.19	-		
$T_j = \text{TOL}$	Pdh	4.8	kW	$T_j = \text{TOL}$	COPd	2.21	-		
$T_j = -15\text{ °C}$ (if TOL < -20 °C)	Pdh		kW	$T_j = -15\text{ °C}$ (if TOL < -20 °C)	COPd		-		
Bivalent temperature	T_{biv}	-10	°C	Min. outdoor air temperature	TOL	-10	°C		
Cycling interval capacity	P _{cy}		kW	Cycling interval efficiency	COP _{cy}		-		
Degradation coefficient	Cdh	0.97	-	Max supply temperature	WTOL	65	°C		
Power consumption in modes other than active mode				Additional heat					
Off mode	P _{OFF}	0.008	kW	Rated heat output	P _{sup}	0.0	kW		
Thermostat-off mode	P _{TO}	0.013	kW						
Standby mode	P _{SB}	0.011	kW	Type of energy input	Electric				
Crankcase heater mode	P _{CK}	0.005	kW						
Other items									
Capacity control	Variable			Rated airflow (air-water)		2,400	m ³ /h		
Sound power level, indoors/outdoors	L _{WA}	- / 49	dB	Nominal heating medium flow			m ³ /h		
Annual energy consumption	Q _{HE}	2,939	kWh	Brine flow brine-water or water-water heat pumps			m ³ /h		
Contact information	NIBE Energy Systems – Box 14 – Hannabadsvägen 5 – 285 21 Markaryd – Sweden								

Model		S2125-12 3x400 V							
Type of heat pump	<input checked="" type="checkbox"/> Air-water <input type="checkbox"/> Exhaust-water <input type="checkbox"/> Brine-water <input type="checkbox"/> Water-water								
Low-temperature heat pump	<input type="checkbox"/> Yes <input checked="" type="checkbox"/> No								
Integrated immersion heater for additional heat	<input type="checkbox"/> Yes <input checked="" type="checkbox"/> No								
Heat pump combination heater	<input type="checkbox"/> Yes <input checked="" type="checkbox"/> No								
Climate	<input checked="" type="checkbox"/> Average <input type="checkbox"/> Cold <input type="checkbox"/> Warm								
Temperature application	<input checked="" type="checkbox"/> Medium (55°C) <input type="checkbox"/> Low (35°C)								
Applied standards	EN14825 / EN14511 / EN12102								
Rated heat output	Prated	7.6	kW	Seasonal space heating energy efficiency	η_s	150	%		
Declared capacity for space heating at part load and at outdoor temperature T_j				Declared coefficient of performance for space heating at part load and at outdoor temperature T_j					
$T_j = -7\text{ °C}$	Pdh	6.7	kW	$T_j = -7\text{ °C}$	COPd	2.17	-		
$T_j = +2\text{ °C}$	Pdh	4.2	kW	$T_j = +2\text{ °C}$	COPd	3.83	-		
$T_j = +7\text{ °C}$	Pdh	2.7	kW	$T_j = +7\text{ °C}$	COPd	5.12	-		
$T_j = +12\text{ °C}$	Pdh	2.4	kW	$T_j = +12\text{ °C}$	COPd	5.87	-		
$T_j = \text{biv}$	Pdh	7.6	kW	$T_j = \text{biv}$	COPd	2.11	-		
$T_j = \text{TOL}$	Pdh	7.6	kW	$T_j = \text{TOL}$	COPd	2.11	-		
$T_j = -15\text{ °C}$ (if TOL < -20 °C)	Pdh		kW	$T_j = -15\text{ °C}$ (if TOL < -20 °C)	COPd		-		
Bivalent temperature	T_{biv}	-10	°C	Min. outdoor air temperature	TOL	-10	°C		
Cycling interval capacity	P _{cych}		kW	Cycling interval efficiency	COP _{cyc}		-		
Degradation coefficient	Cdh	0.97	-	Max supply temperature	WTOL	65	°C		
Power consumption in modes other than active mode				Additional heat					
Off mode	P _{OFF}	0.008	kW	Rated heat output	P _{sup}	0.0	kW		
Thermostat-off mode	P _{TO}	0.013	kW						
Standby mode	P _{SB}	0.011	kW	Type of energy input	Electric				
Crankcase heater mode	P _{CK}	0.005	kW						
Other items									
Capacity control	Variable			Rated airflow (air-water)		2,900	m ³ /h		
Sound power level, indoors/outdoors	L _{WA}	- / 49	dB	Nominal heating medium flow			m ³ /h		
Annual energy consumption	Q _{HE}	4,102	kWh	Brine flow brine-water or water-water heat pumps			m ³ /h		
Contact information	NIBE Energy Systems – Box 14 – Hannabadsvägen 5 – 285 21 Markaryd – Sweden								

Model		S2125-16 3x400 V							
Type of heat pump	<input checked="" type="checkbox"/> Air-water <input type="checkbox"/> Exhaust-water <input type="checkbox"/> Brine-water <input type="checkbox"/> Water-water								
Low-temperature heat pump	<input type="checkbox"/> Yes <input checked="" type="checkbox"/> No								
Integrated immersion heater for additional heat	<input type="checkbox"/> Yes <input checked="" type="checkbox"/> No								
Heat pump combination heater	<input type="checkbox"/> Yes <input checked="" type="checkbox"/> No								
Climate	<input checked="" type="checkbox"/> Average <input type="checkbox"/> Cold <input type="checkbox"/> Warm								
Temperature application	<input checked="" type="checkbox"/> Medium (55°C) <input type="checkbox"/> Low (35°C)								
Applied standards	EN14825 / EN14511 / EN12102								
Rated heat output	Prated	11.0	kW	Seasonal space heating energy efficiency	η_s	160	%		
Declared capacity for space heating at part load and at outdoor temperature T_j				Declared coefficient of performance for space heating at part load and at outdoor temperature T_j					
$T_j = -7\text{ °C}$	Pdh	9.6	kW	$T_j = -7\text{ °C}$	COPd	2.49	-		
$T_j = +2\text{ °C}$	Pdh	5.8	kW	$T_j = +2\text{ °C}$	COPd	4.07	-		
$T_j = +7\text{ °C}$	Pdh	5.1	kW	$T_j = +7\text{ °C}$	COPd	5.25	-		
$T_j = +12\text{ °C}$	Pdh	5.7	kW	$T_j = +12\text{ °C}$	COPd	6.25	-		
$T_j = \text{biv}$	Pdh	10.5	kW	$T_j = \text{biv}$	COPd	2.16	-		
$T_j = \text{TOL}$	Pdh	10.5	kW	$T_j = \text{TOL}$	COPd	2.16	-		
$T_j = -15\text{ °C}$ (if TOL < -20 °C)	Pdh		kW	$T_j = -15\text{ °C}$ (if TOL < -20 °C)	COPd		-		
Bivalent temperature	T_{biv}	-10	°C	Min. outdoor air temperature	TOL	-10	°C		
Cycling interval capacity	P _{cyh}		kW	Cycling interval efficiency	COP _{cyh}		-		
Degradation coefficient	Cdh	0.98	-	Max supply temperature	WTOL	65	°C		
Power consumption in modes other than active mode				Additional heat					
Off mode	P _{OFF}	0.007	kW	Rated heat output	P _{sup}	0.0	kW		
Thermostat-off mode	P _{TO}	0.014	kW						
Standby mode	P _{SB}	0.010	kW	Type of energy input	Electric				
Crankcase heater mode	P _{CK}	0.011	kW						
Other items									
Capacity control	Variable			Rated airflow (air-water)		2,900	m ³ /h		
Sound power level, indoors/outdoors	L _{WA}	- / 55	dB	Nominal heating medium flow			m ³ /h		
Annual energy consumption	Q _{HE}	5,571	kWh	Brine flow brine-water or water-water heat pumps			m ³ /h		
Contact information	NIBE Energy Systems – Box 14 – Hannabadsvägen 5 – 285 21 Markaryd – Sweden								

Model		S2125-20 3x400 V							
Type of heat pump	<input checked="" type="checkbox"/> Air-water <input type="checkbox"/> Exhaust-water <input type="checkbox"/> Brine-water <input type="checkbox"/> Water-water								
Low-temperature heat pump	<input type="checkbox"/> Yes <input checked="" type="checkbox"/> No								
Integrated immersion heater for additional heat	<input type="checkbox"/> Yes <input checked="" type="checkbox"/> No								
Heat pump combination heater	<input type="checkbox"/> Yes <input checked="" type="checkbox"/> No								
Climate	<input checked="" type="checkbox"/> Average <input type="checkbox"/> Cold <input type="checkbox"/> Warm								
Temperature application	<input checked="" type="checkbox"/> Medium (55°C) <input type="checkbox"/> Low (35°C)								
Applied standards	EN14825 / EN14511 / EN12102								
Rated heat output	Prated	11.0	kW	Seasonal space heating energy efficiency	η_s	160	%		
Declared capacity for space heating at part load and at outdoor temperature T_j				Declared coefficient of performance for space heating at part load and at outdoor temperature T_j					
$T_j = -7\text{ °C}$	Pdh	9.6	kW	$T_j = -7\text{ °C}$	COPd	2.49	-		
$T_j = +2\text{ °C}$	Pdh	5.8	kW	$T_j = +2\text{ °C}$	COPd	4.07	-		
$T_j = +7\text{ °C}$	Pdh	5.1	kW	$T_j = +7\text{ °C}$	COPd	5.25	-		
$T_j = +12\text{ °C}$	Pdh	5.7	kW	$T_j = +12\text{ °C}$	COPd	6.25	-		
$T_j = \text{biv}$	Pdh	10.5	kW	$T_j = \text{biv}$	COPd	2.16	-		
$T_j = \text{TOL}$	Pdh	10.5	kW	$T_j = \text{TOL}$	COPd	2.16	-		
$T_j = -15\text{ °C}$ (if TOL < -20 °C)	Pdh		kW	$T_j = -15\text{ °C}$ (if TOL < -20 °C)	COPd		-		
Bivalent temperature	T_{biv}	-10	°C	Min. outdoor air temperature	TOL	-10	°C		
Cycling interval capacity	P _{cy}		kW	Cycling interval efficiency	COP _{cy}		-		
Degradation coefficient	Cdh	0.98	-	Max supply temperature	WTOL	65	°C		
Power consumption in modes other than active mode				Additional heat					
Off mode	P _{OFF}	0.007	kW	Rated heat output	P _{sup}	0.0	kW		
Thermostat-off mode	P _{TO}	0.014	kW						
Standby mode	P _{SB}	0.010	kW	Type of energy input	Electric				
Crankcase heater mode	P _{CK}	0.011	kW						
Other items									
Capacity control	Variable			Rated airflow (air-water)		2,900	m ³ /h		
Sound power level, indoors/outdoors	L _{WA}	- / 55	dB	Nominal heating medium flow			m ³ /h		
Annual energy consumption	Q _{HE}	5,571	kWh	Brine flow brine-water or water-water heat pumps			m ³ /h		
Contact information	NIBE Energy Systems – Box 14 – Hannabadsvägen 5 – 285 21 Markaryd – Sweden								

Electrical circuit diagram

S2125-8, -12

1x230 V

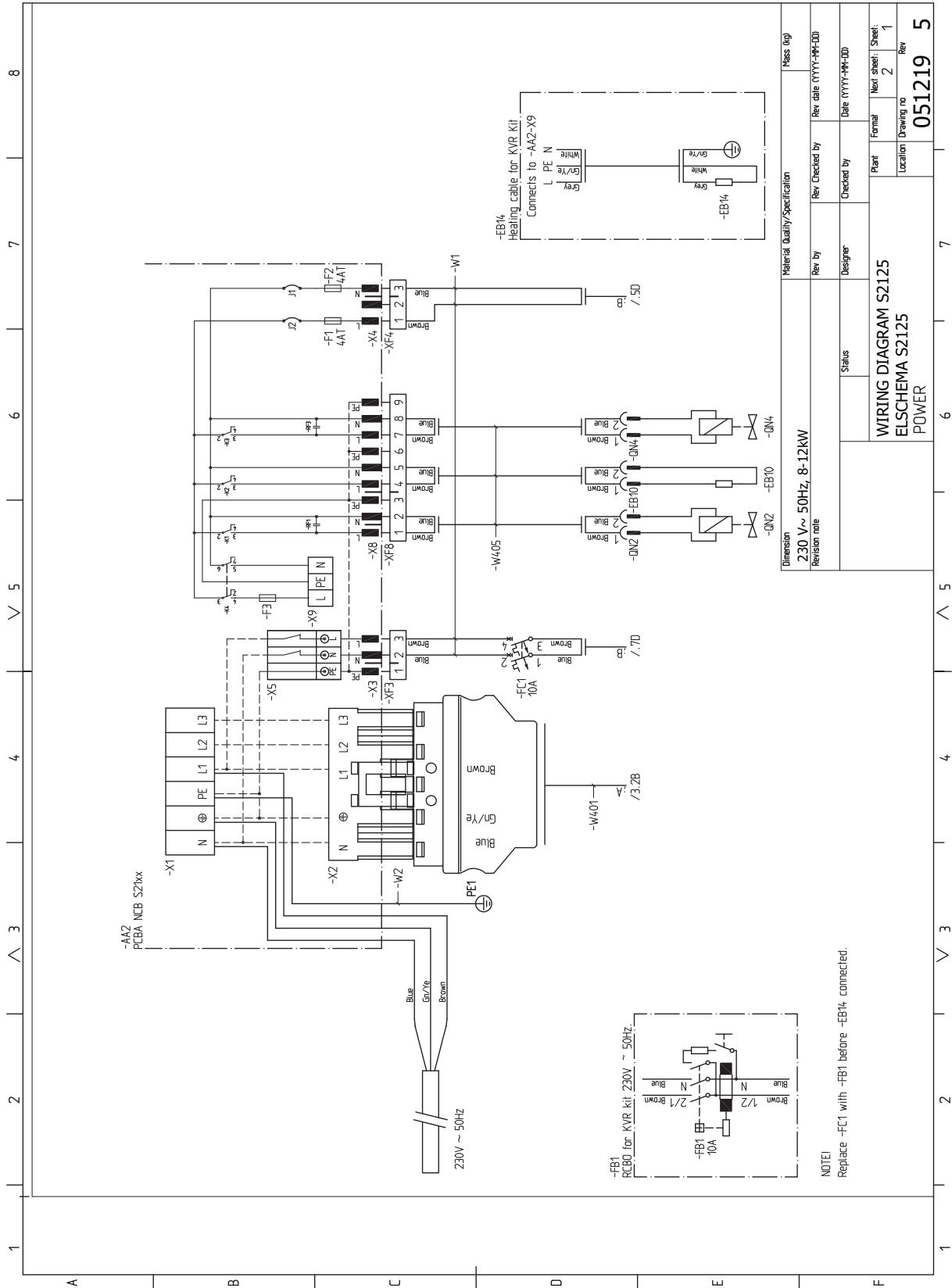

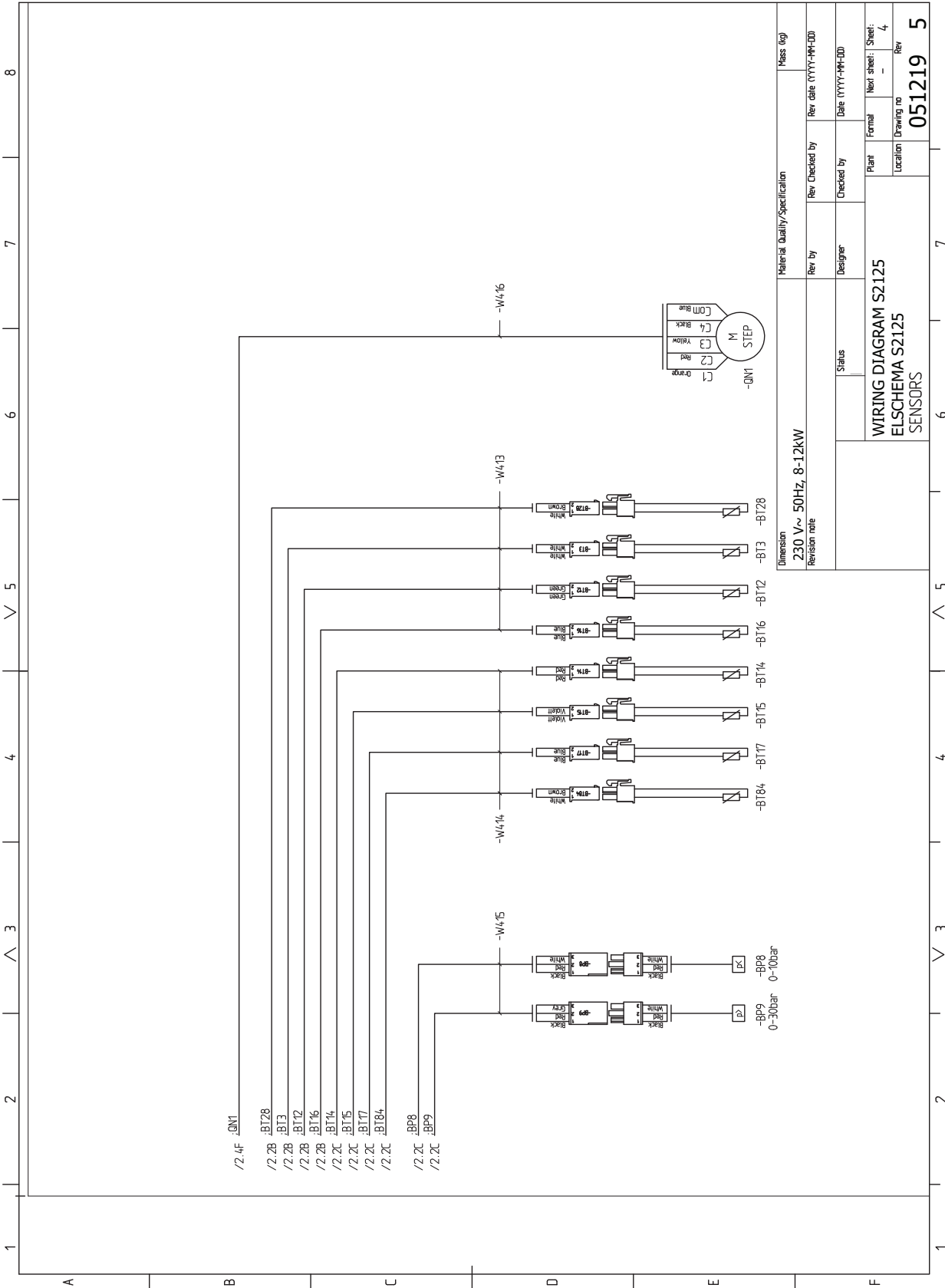

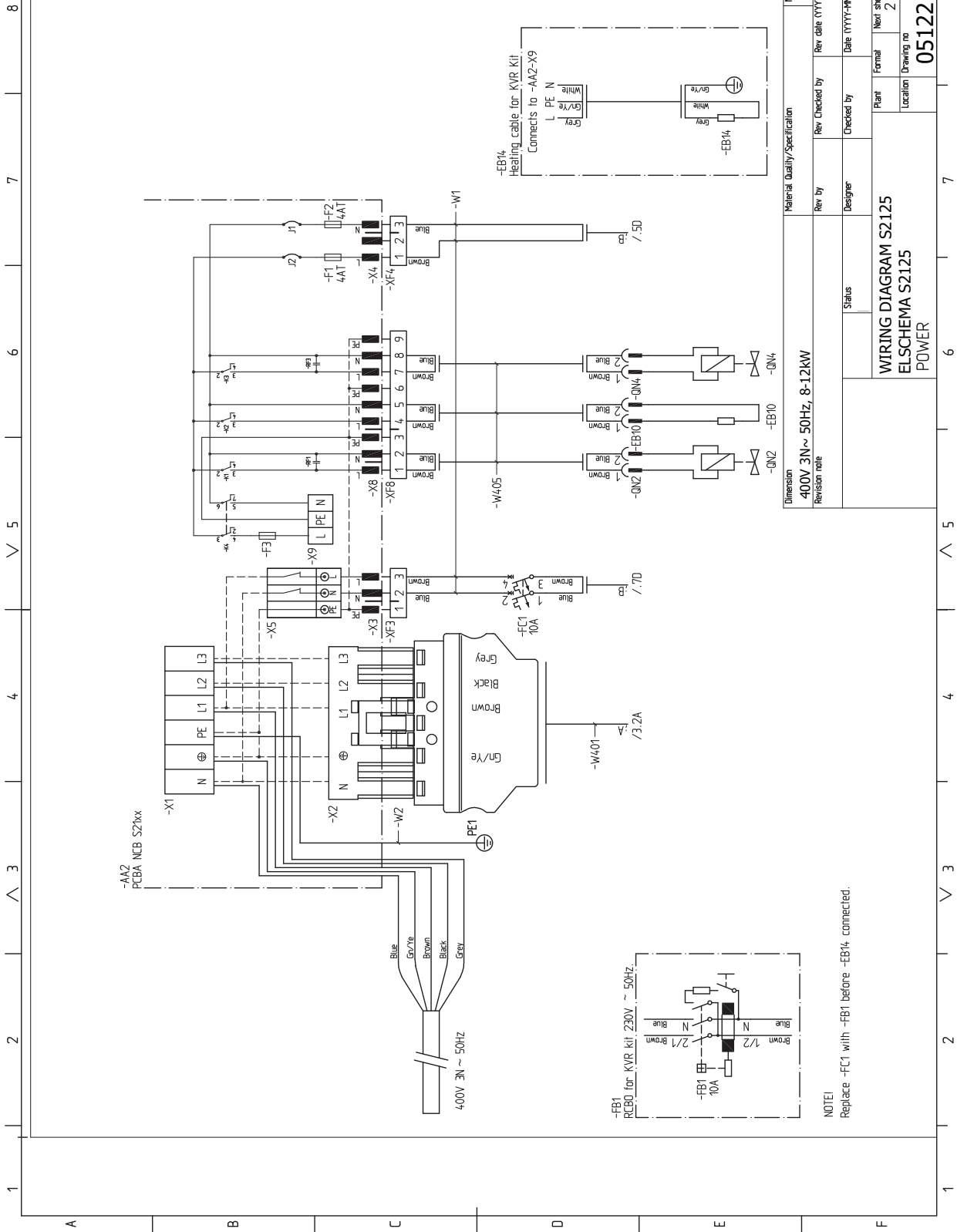

Material Quality/Specification		Mass (kg)	
Dimension	400V 3N~ 50HZ, 8-12KW	Rev Checked by	Rev Date (YYYY-MM-DD)
Revision note		Designer	Date (YYYY-MM-DD)
Status		Plant	Formal
WIRING DIAGRAM S2125		Location	Next sheet: 1
ELSCHEMA S2125		Drawing no	Rev
POWER		051221	4

NOTE!
Replace +FB1 with +FB1 before +EB14 connected.

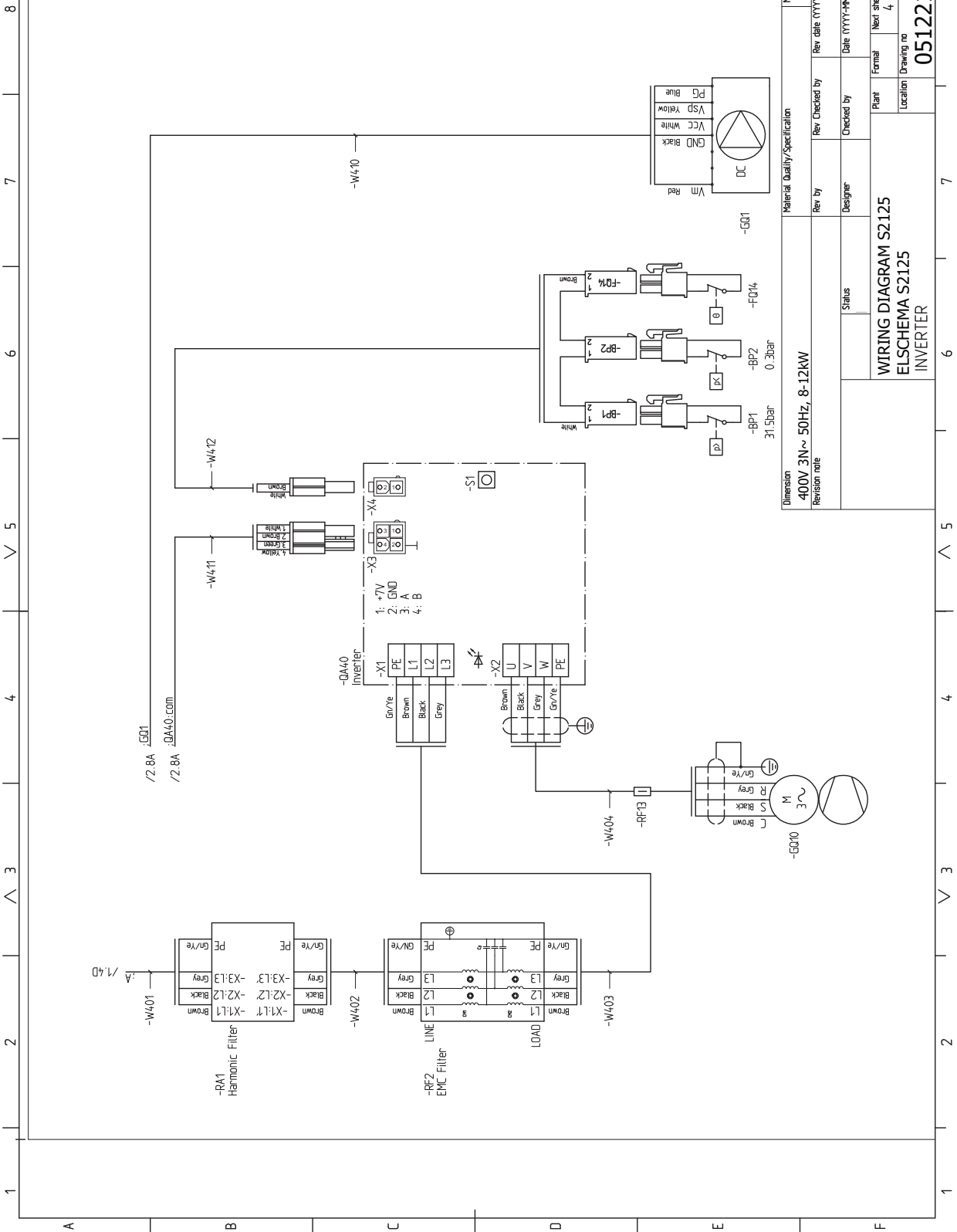

Material Quality/Specification		Mass (kg)	
Dimension	400V 3N~ 50Hz, 8-12kW	Rev By	Rev date (YYYY-MM-DD)
Revision note		Checked by	Date (YYYY-MM-DD)
Status		Rev	Rev
WIRING DIAGRAM S2125		Formal	Next sheet: Sheet
ELSCHEMA S2125		Location	Drawing no
INVERTER			Rev
			051221
			4

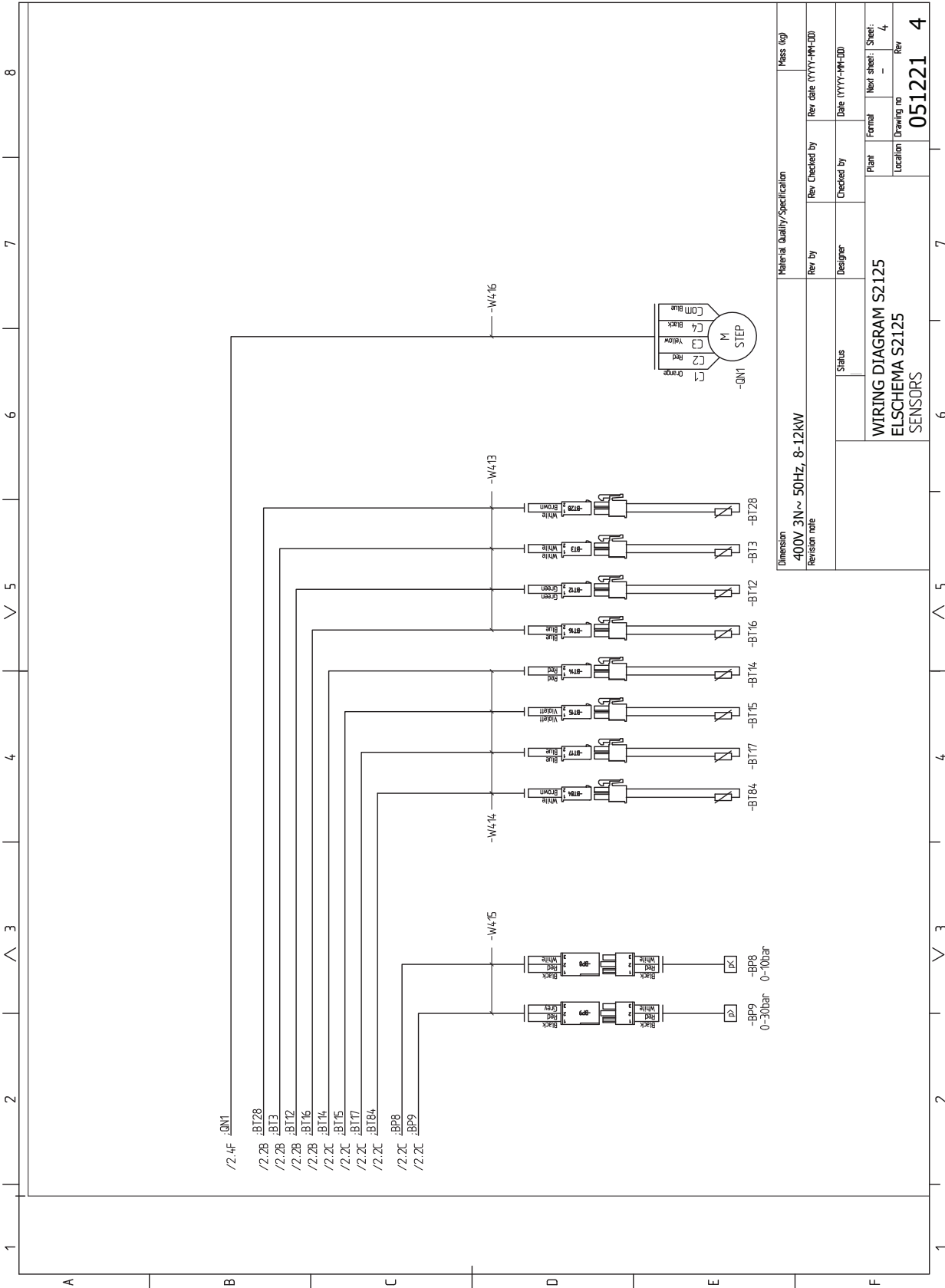

Material Quality/Specification		Mass (kg)	
Dimension	400V 3N~ 50Hz, 8-12KW	Rev. Checked by	Rev. date (YYYY-MM-DD)
Revision note		Designer	Date (YYYY-MM-DD)
Status		Plant	Formal
WIRING DIAGRAM S2125		Location	Next sheet: Sheet: 4
ELSCHEMA S2125		Drawing no	Rev
SENSORS		051221	4

S2125-16, -20

1x230 V

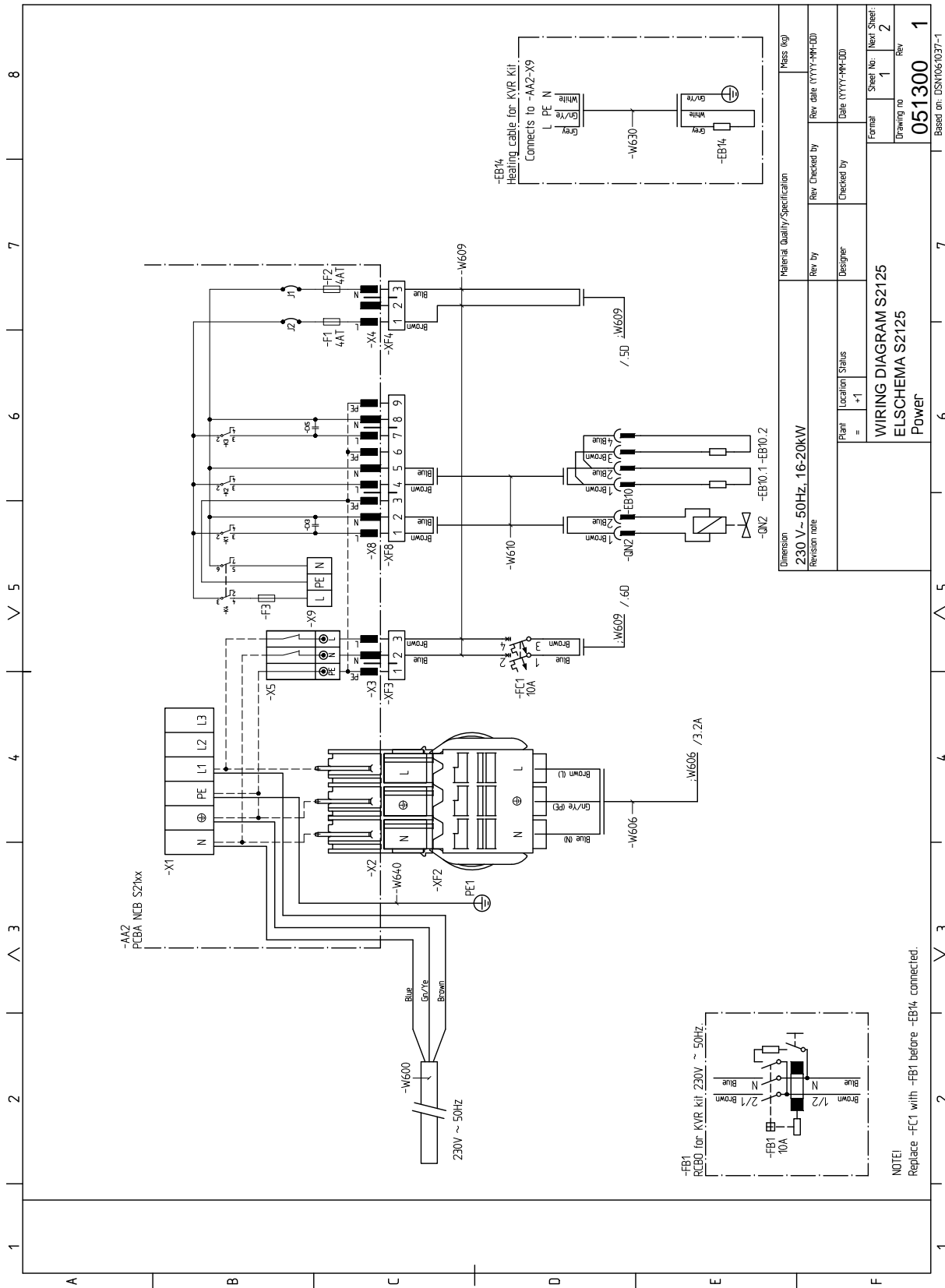

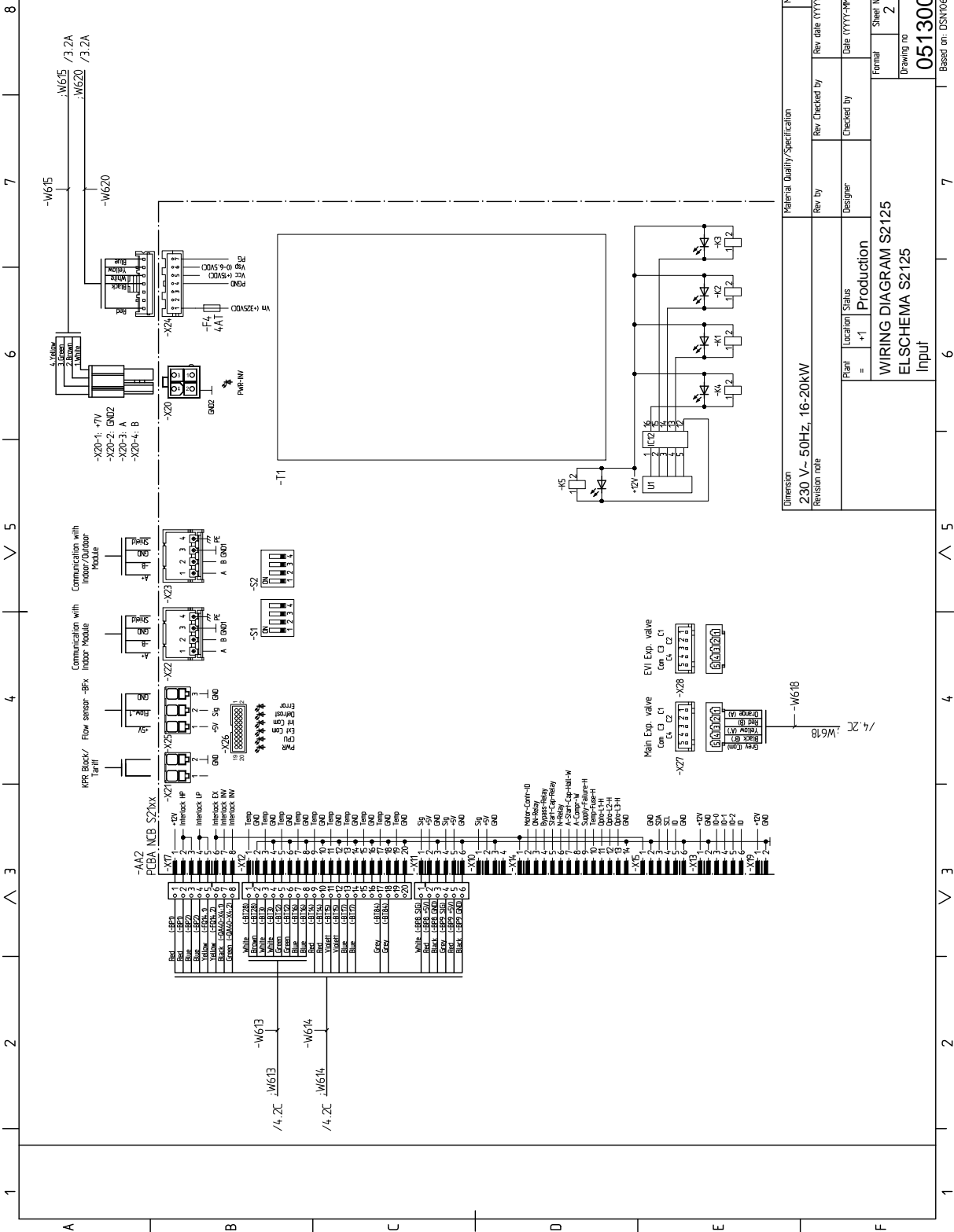

Dimension	Material Quality/Specification		Mass (kg)
Revision note	Rev by	Rev Checked by	Rev date (YYYY-MM-DD)
	Plaint	Location Status	Checked by
	=	+1	Production
	WIRING DIAGRAM S2125		
	ELSCHEMA S2125		
	Input		
Formal	Sheet No.	Next Sheet	
Drawing no	2	3	
	Rev		
	051300	1	

Based on: DSN061037-1

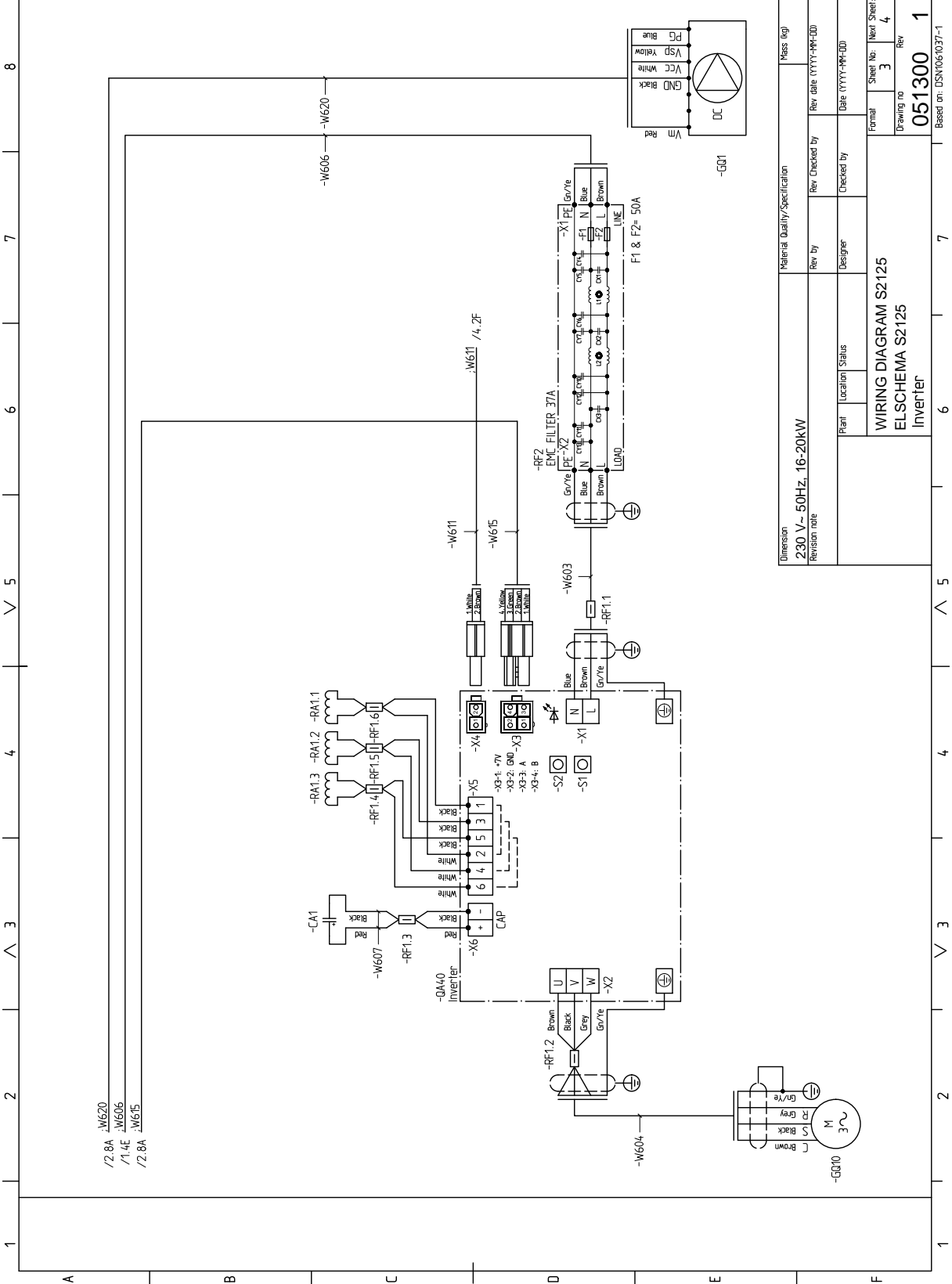

1 2 3 4 5 6 7 8

/2.8A -W620
/1.4E -W606
/2.8A -W615

Dimension	Material Quality/Specification	Mass (kg)
230 V~ 50HZ, 16-20KW		
Revision note	Rev by	Rev date (YYYY-MM-DD)
	Designer	Date (YYYY-MM-DD)
	Location Status	Checked by
WIRING DIAGRAM S2125 ELSHEMA S2125 Inverter		
Formal	Sheet No.	Next Sheet:
Drawing no	3	4
	Rev	
	051300	1
Based on: DSNV061037-1		

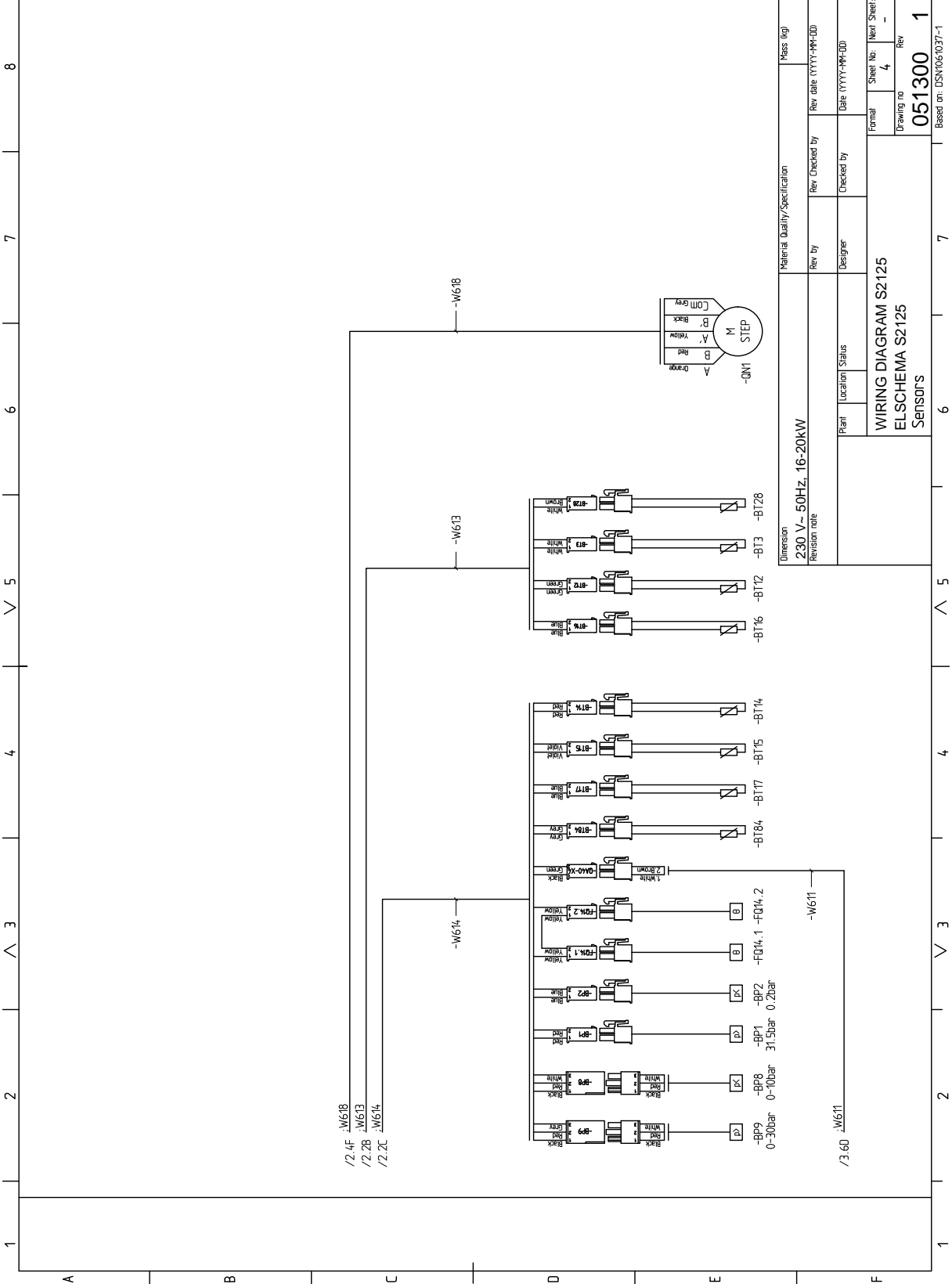

Material Quality/Specification		Mass (kg)
Rev by	Rev Checked by	Rev date (YYYY-MM-DD)
Plant	Location	Status
Checked by		Date (YYYY-MM-DD)
WIRING DIAGRAM S2125		Formal Sheet No. 4
ELSCHEMA S2125		Next Sheet: -
Sensors		Drawing no. 051300
		Rev. 1

Dimension
230 V~ 50Hz, 16-20kW
Revision note

Based on: DSNV061037-1

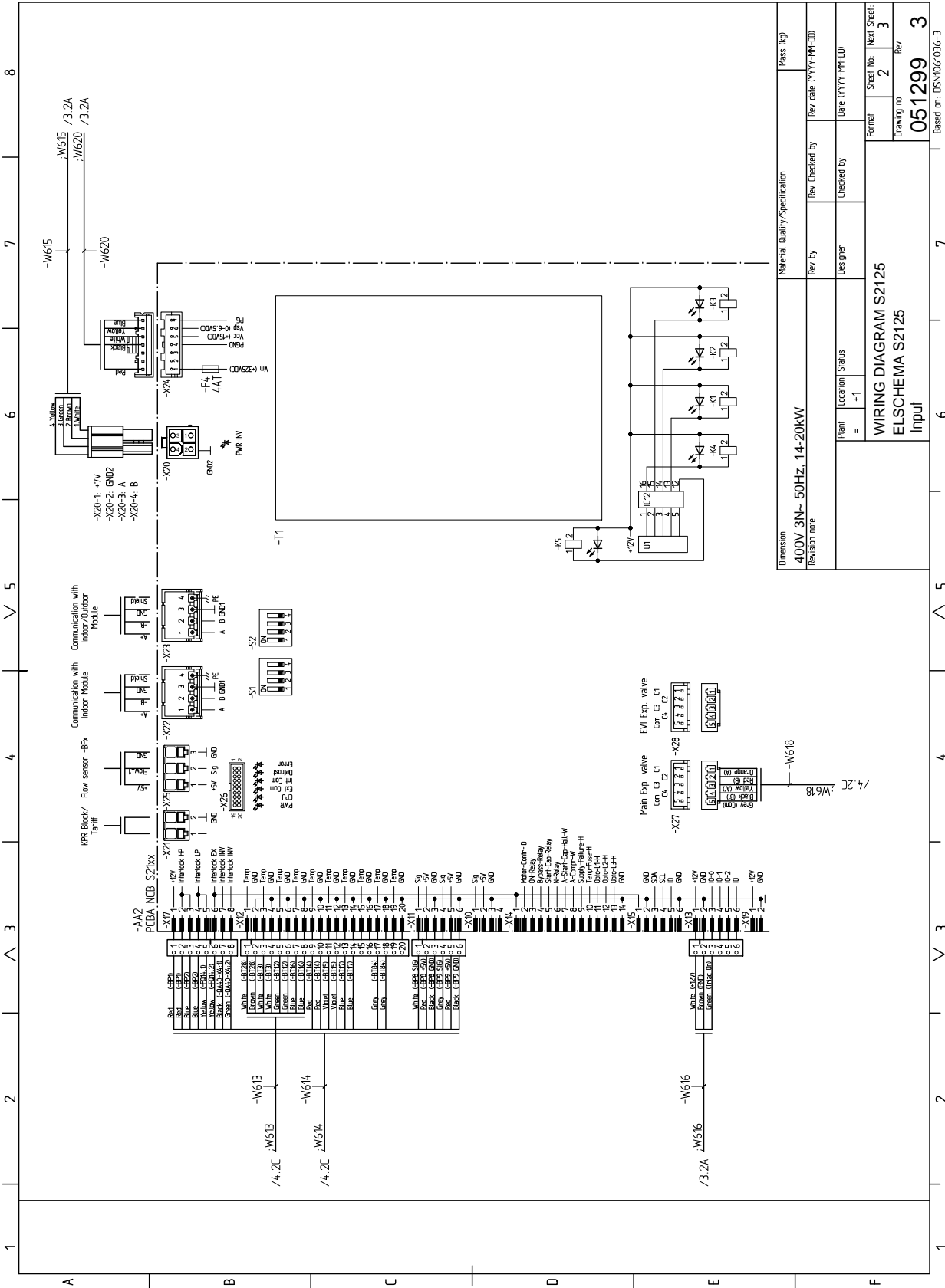

Part Specification Sheet 051299-3
 Page 5/5 Created: 2025-05-27 14:08

Material Quality/Specification		Mass (kg)	
400V 3N- 50Hz, 14-20kW			
Revision note	Rev. by	Rev. Checked by	Rev. Date (YYYY-MM-DD)
	Designer	Checked by	Date (YYYY-MM-DD)
Print = +1	Location Status	Formal	Sheet No. / Next Sheet:
WIRING DIAGRAM S2125			2 / 3
ELSCHEMA S2125			Drawing no
Input			051299
			Rev
			3
Based on: DSN061036-3			

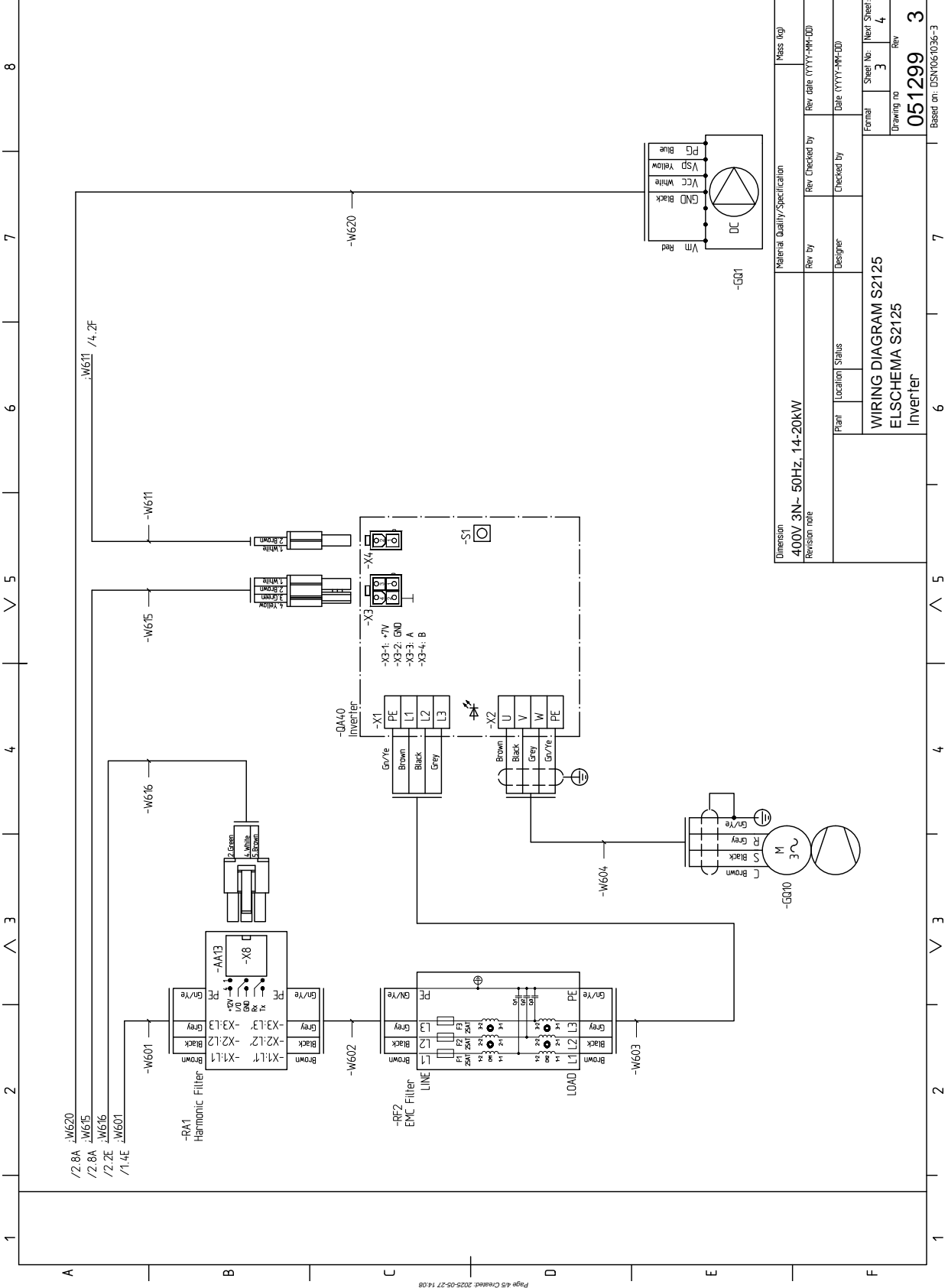

Part Specification Sheet 051299-3
 Page 4/5 Created: 2025-05-27 14:08

Dimension		Material Quality/Specification		Mass (kg)	
400V 3N- 50Hz, 14-20kW					
Revision table		Rev. by	Rev. Checked by	Rev. date (YYYY-MM-DD)	
		Designer	Checked by	Date (YYYY-MM-DD)	
Print	Location	Status		Formal	Sheet No: Next Sheet:
					3 4
WIRING DIAGRAM S2125 ELSCHEMA S2125 Inverter				Drawing no	051299
				Rev	3
				Rev	4
				Rev	051299
				Rev	3
Based on: DSN/061036-3					

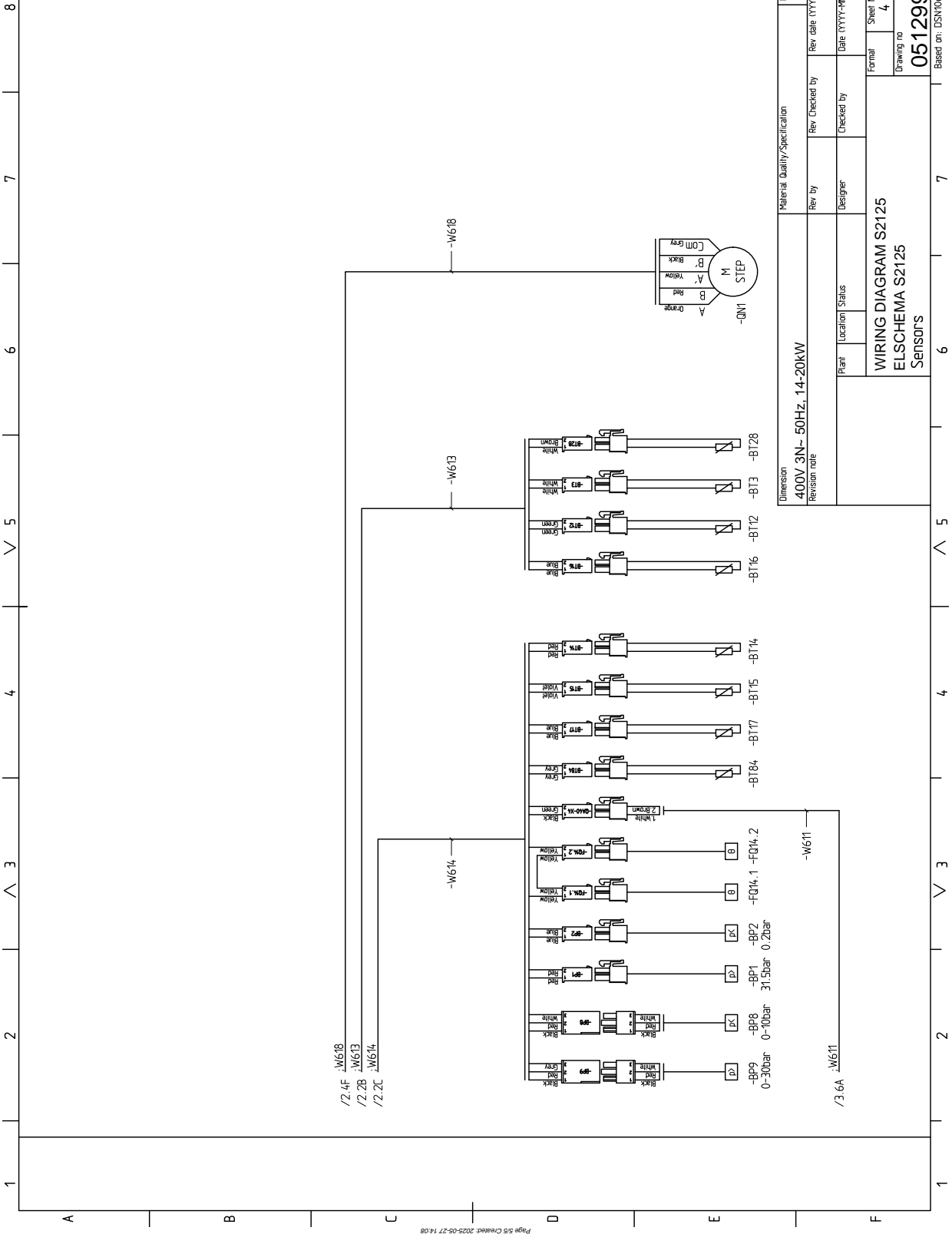

Material Quality/Specification		Mass (kg)	
Dimension	400V 3N-50Hz, 14-20kW	Rev. Checked by	Rev. Date (YYYY-MM-DD)
Revision note		Designer	Date (YYYY-MM-DD)
Print	Location	Status	
WIRING DIAGRAM S2125		Formal	Sheet No: 1 Next Sheet: 4
ELSCHEMA S2125		Drawing no	Rev
Sensors		051299	3

1 2 3 4 5 6 7 8

Item register

- A**
 - Accessories, 43
 - Adjustment, charge flow, 30
 - Alarm list, 40
 - Assembly, 7
- B**
 - Basic actions, 38
- C**
 - Charge pump, 30
 - Commissioning, 29
 - Commissioning and adjusting, 29
 - Adjustment, charge flow, 30
 - Charge pump, 30
 - Commissioning, 29
 - Filling and venting the heating medium system, 29
 - Post adjustment and bleeding, 29
 - Preparations, 29
 - Communication, 27
 - Compressor heater, 29
 - Condensation, 8
 - Connections, 26
 - Control, 31
 - Control conditions, 32
 - Control conditions, defrosting, 32
 - Control - Introduction, 31
 - General, 31
 - Control conditions, 32
 - Control conditions defrosting, 32
 - Control - Heat pump EB101, 33
 - Control - Heat pump EB101
 - Heat pump settings - 5.11.1.1, 35
 - Heat pump settings - Menu 7.3.2, 33
 - Control - Introduction, 31
 - Master control, 31
- D**
 - Data for energy efficiency of the system, 55
 - Delivery and handling, 6
 - Assembly, 7
 - Compressor heater, 29
 - Condensation, 8
 - Installation area, 7
 - Installation of automatic gas separator, 11
 - Removing panels, 10
 - Supplied components, 9
 - Transport, 6
 - Dimensions, 44
 - DIP switches, 28
 - Disruption to comfort
 - Temperature sensor data, 37
 - Distribution boxes, 21
 - Disturbances in comfort, 38
 - Alarm list, 40
 - Troubleshooting, 38
 - Draining the heat pump, 37
- E**
 - Electrical circuit diagram, 64
 - Electrical connections, 25
 - Communication, 27
 - Connections, 26
 - DIP switches, 28
 - General, 25
 - Power connection, 26
 - Tariff control, 27
 - Terminal blocks, 26
 - Energy labelling, 54
 - Data for energy efficiency of the package, 55
 - Information sheet, 54
 - Technical documentation, 56, 60
- F**
 - Filling and venting the heating medium system, 29
- G**
 - General, 25
- H**
 - Heat pump settings - 5.11.1.1, 35
 - Heat pump settings - Menu 7.3.2, 33
 - High room temperature, 38
- I**
 - Ice build-up in the fan, grille and/or fan cone, 38
 - Important information, 4
 - Inspection of the installation, 5
 - Safety information, 4
 - System solutions, 5
 - Information sheet, 54
 - Inspection of the installation, 5
 - Installation area, 7
 - Installation of automatic gas separator, 11
 - Installing the installation
 - Symbol key, 23
- L**
 - Large amount of water below S2125, 38
 - Low hot water temperature or no hot water, 38
 - Low room temperature, 38
- M**
 - Marking, 4
 - Master control, 31
- P**
 - Pipe connections, 23
 - General, 23
 - Pipe coupling, heating medium, 24
 - Symbol key, 23
 - Water volumes, 23
 - Pipe coupling, heating medium, 24
 - Post adjustment and bleeding, 29
 - Power connection, 26
 - Preparations, 29
- R**
 - Removing panels, 10
- S**
 - S2125 does not start, 38
 - S2125 not communicating, 38
 - Safety information, 4
 - Marking, 4
 - Serial number, 4
 - Symbols, 4
 - Serial number, 4
 - Service, 37
 - Service actions, 37
 - Service actions, 37
 - Service measures
 - Draining the heat pump, 37

Sound levels, 46
Supplied components, 9
Symbol key, 23
Symbols, 4
System solutions, 5

T

Tariff control, 27
Technical data, 44
 Dimensions, 44
 Electrical circuit diagram, 64
 Energy labelling, 54
 Data for energy efficiency of the system, 55
 Information sheet, 54
 Technical documentation, 56
 Sound pressure levels, 46
 Technical Data, 47
Technical Data, 47
Technical documentation, 56
Temperature sensor data, 37
Terminal blocks, 26
The heat pump design, 14
 Component locations, 14
 List of components, 14
The heat pump's design
 Distribution boxes, 21
Transport, 6
Troubleshooting, 38
 Basic actions, 38
 High room temperature, 38
 Ice build-up in the fan, grille and/or fan cone, 38
 Large amount of water below S2125, 38
 Low hot water temperature or no hot water, 38
 Low room temperature, 38
 S2125 does not start, 38
 S2125 not communicating, 38

Contact information

AUSTRIA

KNV Energietechnik GmbH
Gahberggasse 11, 4861 Schörfling
Tel: +43 (0)7662 8963-0
mail@knv.at
knv.at

FINLAND

NIBE Energy Systems Oy
Juurakkotie 3, 01510 Vantaa
Tel: +358 (0)9 274 6970
info@nibe.fi
nibe.fi

GREAT BRITAIN

NIBE Energy Systems Ltd
3C Broom Business Park,
Bridge Way, S41 9QG Chesterfield
Tel: +44 (0)330 311 2201
info@nibe.co.uk
nibe.co.uk

POLAND

NIBE-BIAWAR Sp. z o.o.
Al. Jana Pawla II 57, 15-703 Bialystok
Tel: +48 (0)85 66 28 490
biawar.com.pl

CZECH REPUBLIC

Družstevní závody Dražice - strojírna
s.r.o.
Dražice 69, 29471 Benátky n. Jiz.
Tel: +420 326 373 801
nibe@nibe.cz
nibe.cz

FRANCE

NIBE Energy Systems France SAS
Zone industrielle RD 28
Rue du Pou du Ciel, 01600 Reyrieux
Tél: 04 74 00 92 92
info@nibe.fr
nibe.fr

NETHERLANDS

NIBE Energietechnik B.V.
Energieweg 31, 4906 CG Oosterhout
Tel: +31 (0)168 47 77 22
info@nibenl.nl
nibenl.nl

SWEDEN

NIBE Energy Systems
Box 14
Hannabadsvägen 5, 285 21 Markaryd
Tel: +46 (0)433-27 30 00
info@nibe.se
nibe.se

DENMARK

Vølund Varmeteknik A/S
Industrivej Nord 7B, 7400 Herning
Tel: +45 97 17 20 33
info@volundvt.dk
volundvt.dk

GERMANY

NIBE Systemtechnik GmbH
Am Reiherpfahl 3, 29223 Celle
Tel: +49 (0)5141 75 46 -0
info@nibe.de
nibe.de

NORWAY

ABK-Qviller AS
Brobekkeveien 80, 0582 Oslo
Tel: (+47) 23 17 05 20
post@abkqviller.no
nibe.no

SWITZERLAND

NIBE Wärmetechnik c/o ait Schweiz AG
Industriepark, CH-6246 Altishofen
Tel. +41 (0)58 252 21 00
info@nibe.ch
nibe.ch

For countries not mentioned in this list, contact NIBE Sweden or check nibe.eu for more information.

NIBE Energy Systems
Hannabadsvägen 5
Box 14
SE-285 21 Markaryd
info@nibe.se
nibe.eu

IHB EN 2525-1 831880

This is a publication from NIBE Energy Systems. All product illustrations, facts and data are based on the available information at the time of the publication's approval.

NIBE Energy Systems makes reservations for any factual or printing errors in this publication.

©2025 NIBE ENERGY SYSTEMS

