



NIBE

Heat pump water heater

NIBE VPB S

The NIBE VPB S is efficient heat pump water heaters which is designed for connection to a heat pump.

The NIBE VPB S and the ground source heat pump NIBE S1156 have a customised design, providing a stylish system solution with the option of concealed piping between the products.

The NIBE VPB S has insulation made of polyurethane, which provides very good heat insulation.

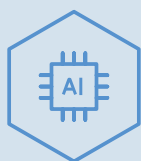

- **Efficient heat pump water heater designed for connection to a heat pump or other energy source.**
- **Stylish design for customisation with NIBE heat pump.**
- **Minimal heat loss with polyurethane insulation.**

Good to know about NIBE VPB S

SYSTEM DIAGRAM

This is the outline diagram. Actual installations must be planned according to applicable standards.

VPB S is a series of water heaters that are suitable for connection to e.g. a heat pump.

Further information about the system principle is available at nibe.eu and in the manuals for the heat sources used.

VPB S200 / VPB S300

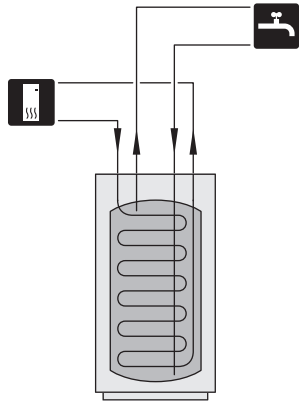

DESIGN

VPB S has internal copper, stainless steel or enamel corrosion protection.

VPB S is equipped with a charge coil that heats the domestic water, resulting in excellent properties for hot water charging.

VPB S is designed and manufactured for a maximum cut-off pressure of 10 bar.

The insulation is polyurethane, which provides excellent thermal insulation.

VPB S is equipped with three sensors for external control and display of the hot water heating.

VPB S Enamel is supplied from the factory with a direct-current anode and an enclosed potentiostat.

TRANSPORT AND STORAGE

VPB S must be transported and stored vertically.

Check that VPB S has not been damaged during transport.

COMPATIBLE PRODUCTS

Information about compatible products can be found at nibe.eu.

INSTALLATION AND POSITIONING

- VPB S must only be installed vertically.
- Position VPB S on a firm base that can take the weight, preferably on a concrete floor or foundation. Use the adjustable feet to obtain a horizontal and stable set-up.
- The area where the VPB S is located must be frost-proof and equipped with a floor drain.

SUPPLIED COMPONENTS

VPB S (Enamel)

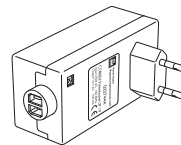

Potentiostat

Pressure drop diagram, charge coil

VPB S200

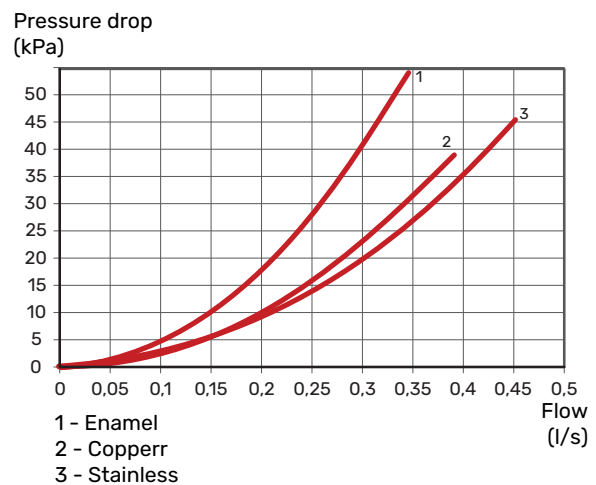

VPB S300

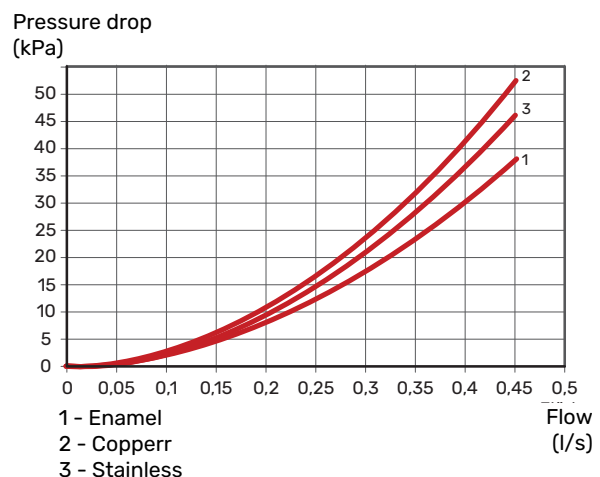

Electrical installation

Electrical installation and service must be carried out under the supervision of a qualified electrician. Electrical installation and wiring must be carried out in accordance with the stipulations in force.

SENSORS

VPB S200 and VPB S300 have three sensors supplied from the factory, one for display and two for control. The sensors are placed in submerged tubes. Connect the sensor cables to a compatible product according to the list on page 2. See the product manual for connecting sensors.

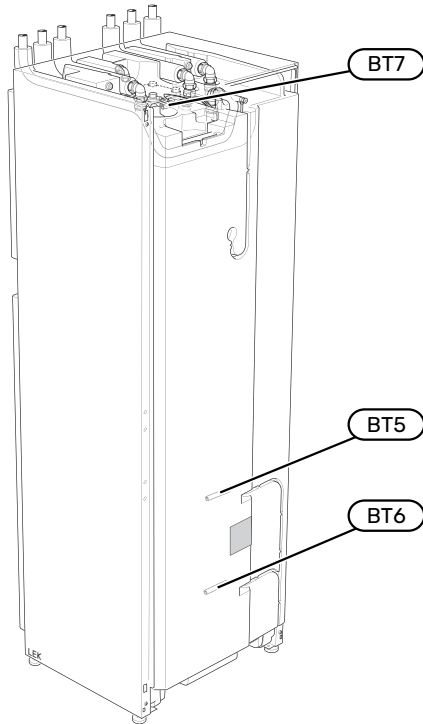

DIRECT-CURRENT ANODE

VPB S Enamel is supplied from the factory with a direct-current anode and an enclosed potentiostat. The anode cable is installed in the anode from the factory and only needs to be connected to the potentiostat.

VPB S Enamel is equipped with direct-current anode and supplied with potentiostat from the factory. The anode cable (W1) is installed in the anode from the factory and only needs to be connected to the potentiostat.

1. Route the anode cable (W1) along the docking pipe, flow line (XL8).
2. Connect the anode cable (W1) to the potentiostat.
3. Connect the potentiostat to a suitable 230 V wall socket.

The cable between the potentiostat and the anode must either be extended or shortened.

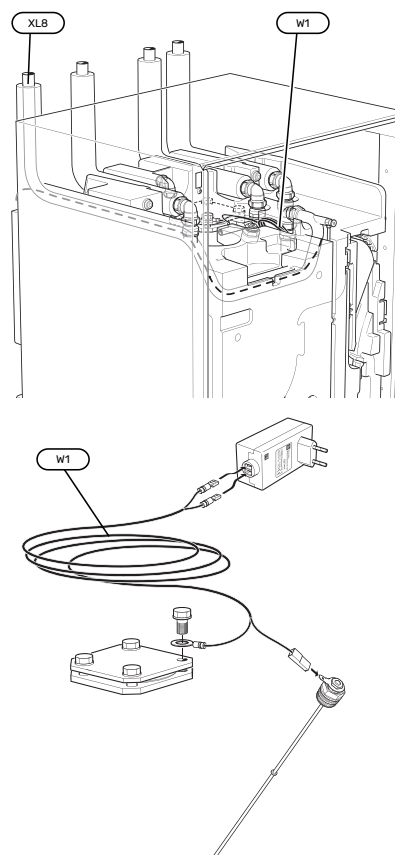

The figure shows VPB S200 Enamel.

Technical data

DIMENSIONS

VPB S200 / VPB S300

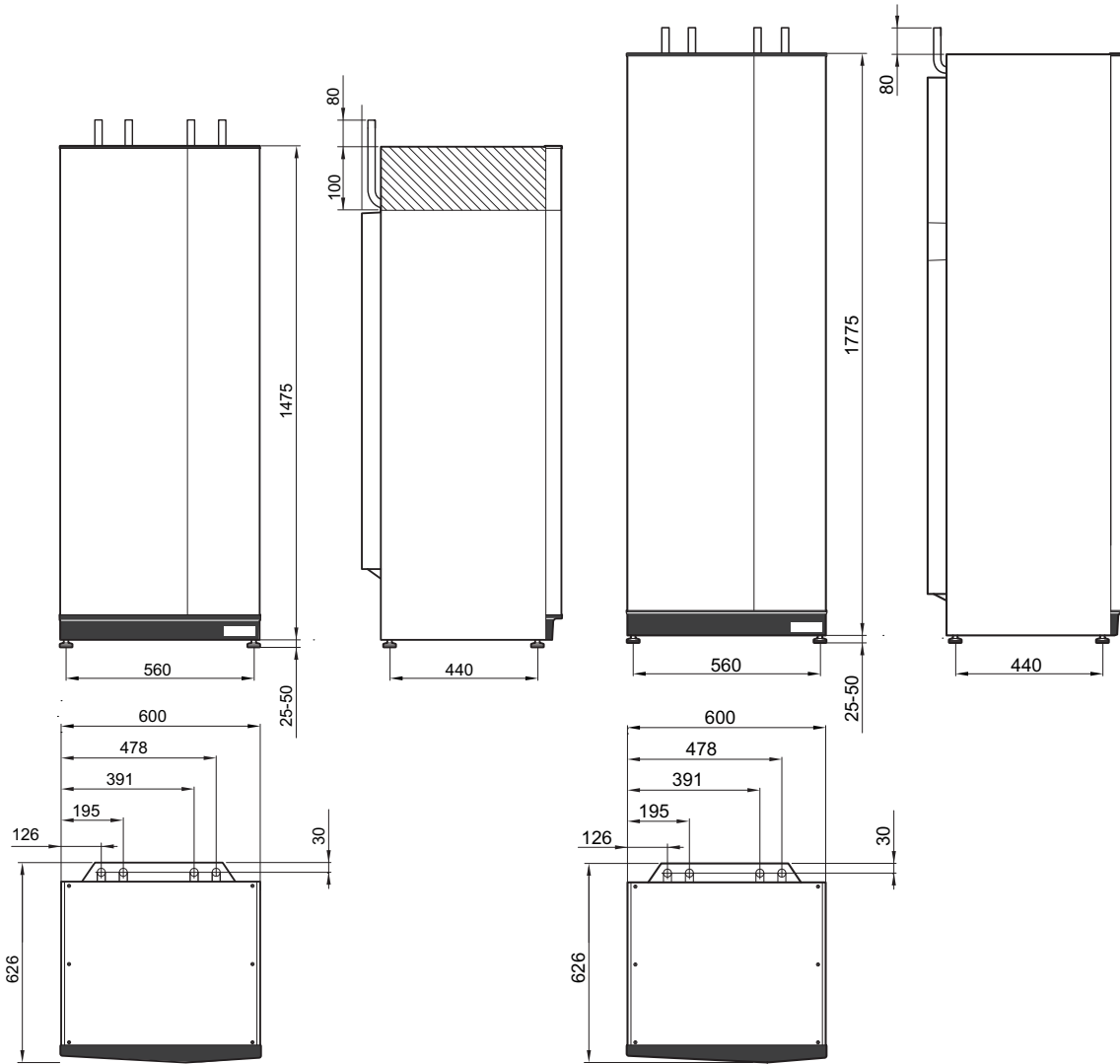

PIPE CONNECTIONS

VPB S200 / VPB S300

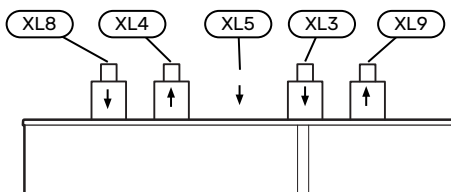

Connection	mm	
XL3 Cold water Ø	mm	22
XL4 Hot water Ø	mm	22
XL5 Hot water circulation Ø	mm	15
XL8 Docking connection, supply line Ø	mm	22
XL9 Docking connection, return line Ø	mm	22

TECHNICAL SPECIFICATIONS

VPB S200		Copper	Enamel	Stainless
Heating medium circuit				
Max pressure in the heating medium circuit	bar/MPa	0.3 (3)		
Pipe connections				
Hot water ext Ø	mm	22		
Cold water ext Ø	mm	22		
Hot water circulation ext Ø	mm	15		
Docking ext Ø	mm	22		
Max operating temperature	°C	85		
Opening pressure, safety valve	MPa (bar)	1.0 (10)		
Heating time (10°C to 50°C) 8 kW charge power	h	1		
Equivalent amount of hot water (40 °C) ¹	litre	230	238	235
Dimensions and weight				
Width	mm	600		
Depth	mm	626		
Height	mm	1500		
Ceiling height	mm	1670 ²		
Weight	kg	101	111	80
Part No.		081 139	081 140	081 141
EPREL		248 646	248 647	248 648

¹ At incoming temperature 10 °C and a domestic water flow of 0.25 l/s.

² Med fötterna avmonterade blir reshöjden ca. 1650 mm.

VPB S300		Copper	Enamel	Stainless
Heating medium circuit				
Max pressure in the heating medium circuit	bar/MPa	0.3 (3)		
Pipe connections				
Hot water ext Ø	mm	22		
Cold water ext Ø	mm	22		
Hot water circulation ext Ø	mm	15		
Docking ext Ø	mm	22		
Max operating temperature	°C	85		
Opening pressure, safety valve	MPa (bar)	1.0 (10)		
Heating time (10°C to 50°C) 8 kW charge power	h	1.5		
Equivalent amount of hot water (40 °C) ¹	litre	362	364	376
Dimensions and weight				
Width	mm	600		
Depth	mm	626		
Height	mm	1800		
Ceiling height	mm	1950 ²		
Weight	kg	130	143	101
Part No.		081 142	081 144	081 143
EPREL		248 649	248 651	248 650

¹ At incoming temperature 10 °C and a domestic water flow of 0.5 l/s.

² Med fötterna avmonterade blir reshöjden ca. 1930 mm.

ENERGY LABELLING

Supplier		NIBE	
Model		VPB S200 Koppar/Emalj/Rostfritt	VPB S300 Koppar/Emalj/Rostfritt
Efficiency class ¹		C	C
Heat loss	W	66	88
Volume	l	178 / 178 / 176	278 / 274 / 282

¹ Scale for the product's efficiency class A+ to F.





Sustainable energy solutions since 1952

NIBE has since 1952 been manufacturing energy-efficient and sustainable climate solutions for your home. It all began in Markaryd, in the southern Swedish province of Småland, and we recognise our Nordic heritage by utilising the power of nature. We combine renewable energy with smart technology to offer efficient solutions, allowing us to work together to create a more sustainable future.

Regardless of whether it is a chilly winter's day or a warm afternoon in the summer sun, we need a balanced indoor climate that allows us to enjoy a comfortable life, whatever the weather. Our extensive range of products supply your home with cooling, heating, ventilation and hot water, making it possible for you to create a pleasant indoor climate with little impact on the environment.

NIBE Energy Systems
Box 14, SE-285 21 Markaryd
nibe.eu

NIBE

This product sheet is a publication from NIBE Energy Systems. All product illustrations, facts and data are based on current information at the time of the publication's approval. NIBE Energy Systems makes reservations for any factual or printing errors in this product sheet.

©2025 NIBE ENERGY SYSTEMS
PBD EN 2512-3 M12525