

Heat pump water heater **NIBE VPB S200, S300**

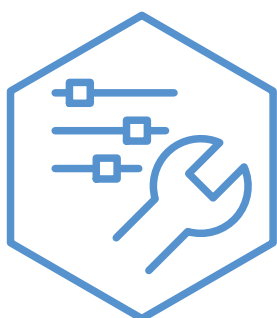

Table of Contents

1	Important information _____	4
	Safety information _____	4
	General _____	4
	Serial number _____	4
	Recovery _____	4
2	For the User _____	5
	Maintenance _____	5
3	For the Installer _____	6
	Compatible products _____	6
	Delivery and handling _____	6
	The water heater design _____	8
	Pipe connections _____	8
	Electrical installation _____	10
	Commissioning and adjusting _____	12
4	Technical data _____	13
	Dimensions _____	13
	Technical specifications _____	14
	Energy labelling _____	14
	Contact information _____	15

Important information

Safety information

This manual describes installation and service procedures for implementation by specialists.

The manual must be left with the customer.

For the latest version of the product's documentation, see nibe.eu.

This appliance can be used by children aged from 8 years and above and persons with reduced physical, sensory or mental capabilities or lack of experience and knowledge if they have been given supervision or instruction concerning use of the appliance in a safe way and understand the hazards involved. Children shall not play with the appliance. Cleaning and user maintenance shall not be made by children without supervision.

This is an original manual. It may not be translated without the approval of NIBE.

Rights to make any design or technical modifications are reserved.

©NIBE 2025.

Water may drip from the safety valve's overflow pipe. The overflow pipe must be routed to a suitable drain, to prevent hot water splashes from causing harm. The overflow pipe must be inclined along its entire length to prevent pockets where water can accumulate, and must be frost-proof. The overflow pipe must be at least the same size as the safety valve. The overflow pipe must be visible and its mouth must be open and not placed close to electrical components.

The safety valves must be actuated regularly to remove dirt and to check that they are not blocked.

SYMBOLS

Explanation of symbols that may be present in this manual.



CAUTION!

This symbol indicates danger to person or machine.



NOTE!

This symbol indicates important information about what you need to consider when installing, servicing or maintaining the installation.

MARKING

Explanation of symbols that may be present on the product's label(s).



Danger to person or machine.



Read the User Manual.

General

NIBE VPB S is designed and manufactured according sound engineering practice¹ in order to ensure safe usage.

¹ Pressure Equipment Directive 2014/68/EU Article 4 point 3.

Serial number

The serial number can be found at the bottom right of the front cover.



NOTE!

You need the product's (14 digit) serial number for servicing and support.

Recovery



Leave the disposal of the packaging to the installer who installed the product or to special waste stations.

Do not dispose of used products with normal household waste. It must be disposed of at a special waste station or dealer who provides this type of service.

Improper disposal of the product by the user results in administrative penalties in accordance with current legislation.

For the User

Maintenance

SAFETY VALVE(NOT ENCLOSED)

You can find the safety valve on the incoming pipe (cold water) to NIBE VPB S.

The water heater's safety valve sometimes releases a little water after hot water usage. This is because the cold water, which enters the water heater to replace the hot water, expands when heated causing the pressure to rise and the safety valve to open.

The function of the safety valve must be checked regularly. Perform checks as follows:

1. Open the valve.
2. Check that water is flowing through it.
3. Close the valve.



CAUTION!

If this pressurised water heater develops a fault, e.g. a flow of hot water from the overflow pipe, turn the heat pump off and contact your installer.



CAUTION!

Do not remove or adjust any components that are part of this pressurised water heater. Contact your installer!



TIP!

The safety valve is not delivered with NIBE VPB S. Contact your installer if you are unsure how to check it.

EMPTYING

The water heater

Draining is performed through the siphon (using hose) in the cold water connection (XL3).

Charge coil

Draining is performed through the siphon (using hose) in the docking connection, return to heat pump (XL9).

VPB S200 / VPB S300

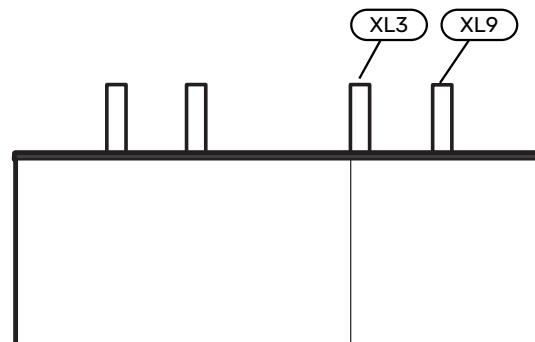

SERVICE

If servicing is required, contact your installer.



NOTE!

You need the product's (14 digit) serial number for servicing and support.

Servicing should only be carried out by persons with the necessary expertise.

When replacing components on NIBE VPB S only replacement parts from NIBE may be used.

For the Installer

Compatible products

Information about compatible products can be found at nibe.eu.

Delivery and handling

TRANSPORT

NIBE VPB S should be transported and stored vertically in a dry place.

However, the NIBE VPB S can be carefully laid on its back when being moved into the building.

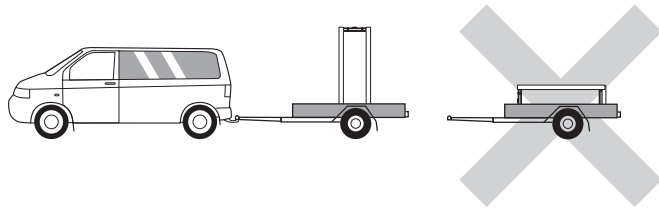

ASSEMBLY

- Position NIBE VPB S on a solid foundation indoors that withstands water and the weight of the product.
- Use the product's adjustable feet to attain a horizontal and stable set-up.

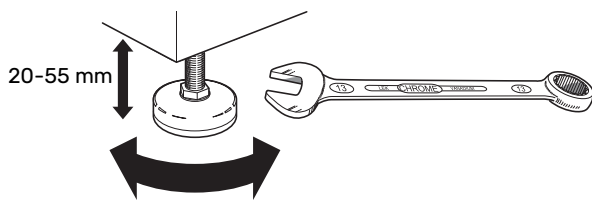

- Since water comes from NIBE VPB S, the area where NIBE VPB S is located must be equipped with floor drainage.
- The space where NIBE VPB S is located must be frost-free.

SUPPLIED COMPONENTS

NIBE VPB S (Only enamel)

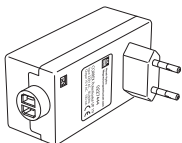

1 x Potentiostat

HANDLING PANELS

Remove the front

1. Pull the panel's top edge towards you and lift diagonally upwards to remove it from the frame.

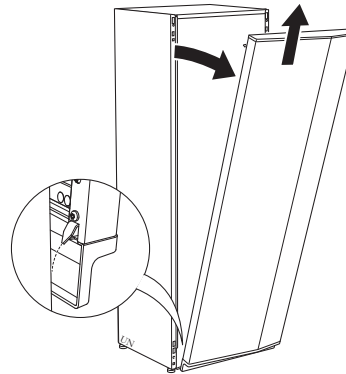

Assemble the front

1. Hook one bottom corner of the front onto the frame.

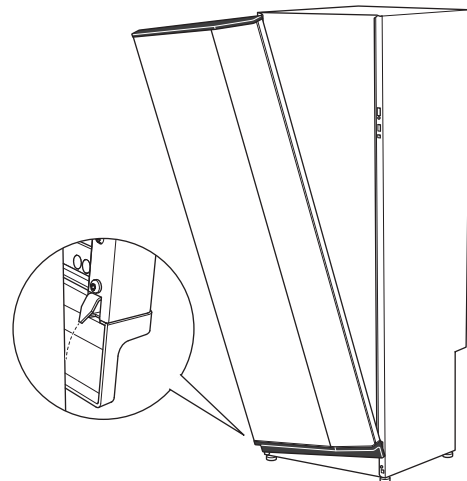

2. Hook the other corner in place.

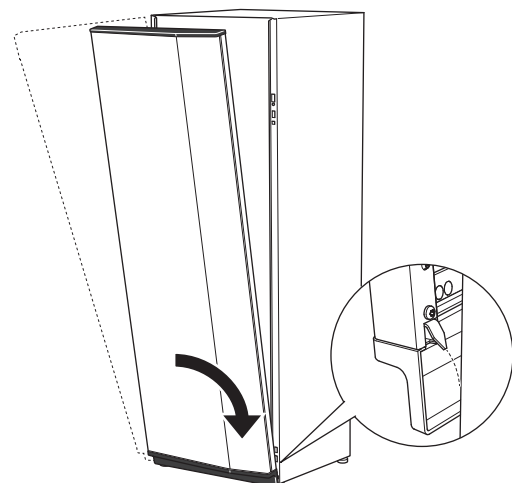

3. Press the front's top section against the frame.

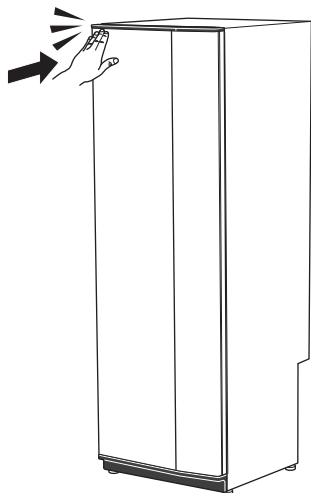

3. Move the panel outwards and backwards.

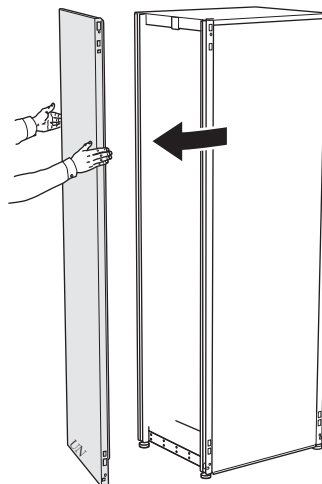

Remove side panels

The side panels can be removed to facilitate the installation.

1. Remove the screws from the upper and lower edges.

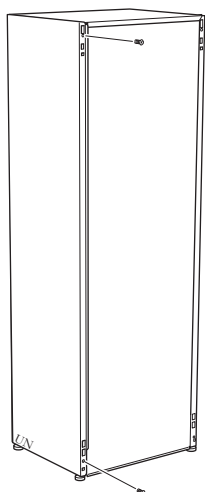

2. Twist the panel slightly outwards.

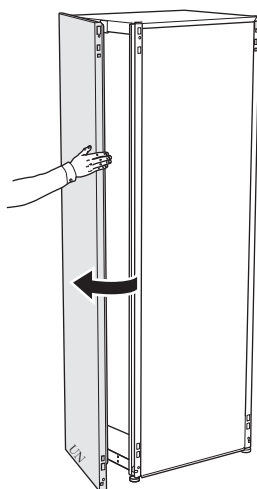

4. Assembly takes place in the reverse order.

The water heater design

VPB S200

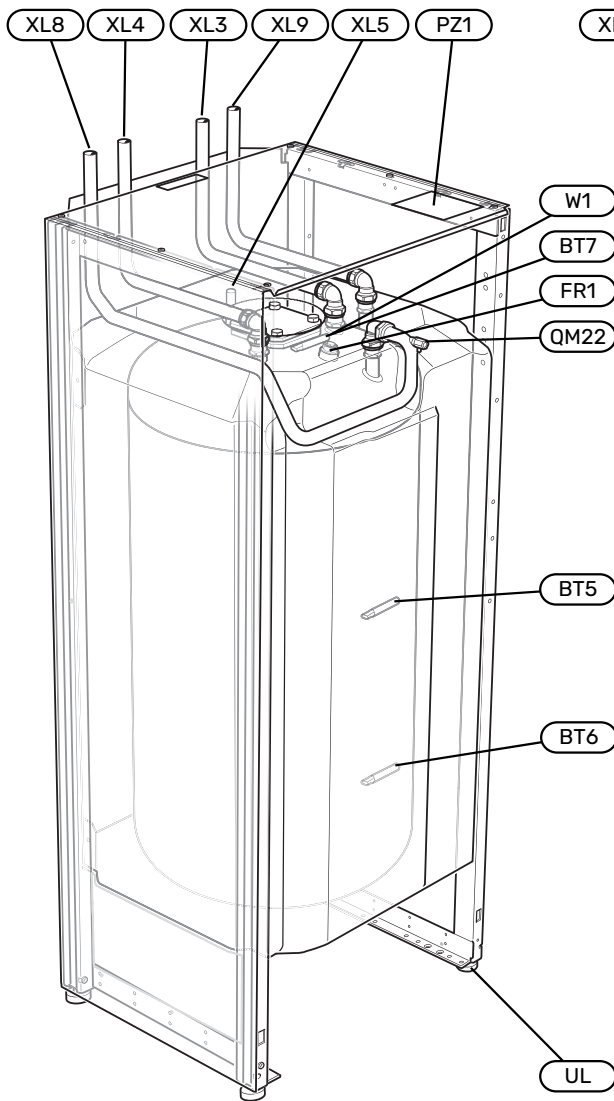

VPB S300

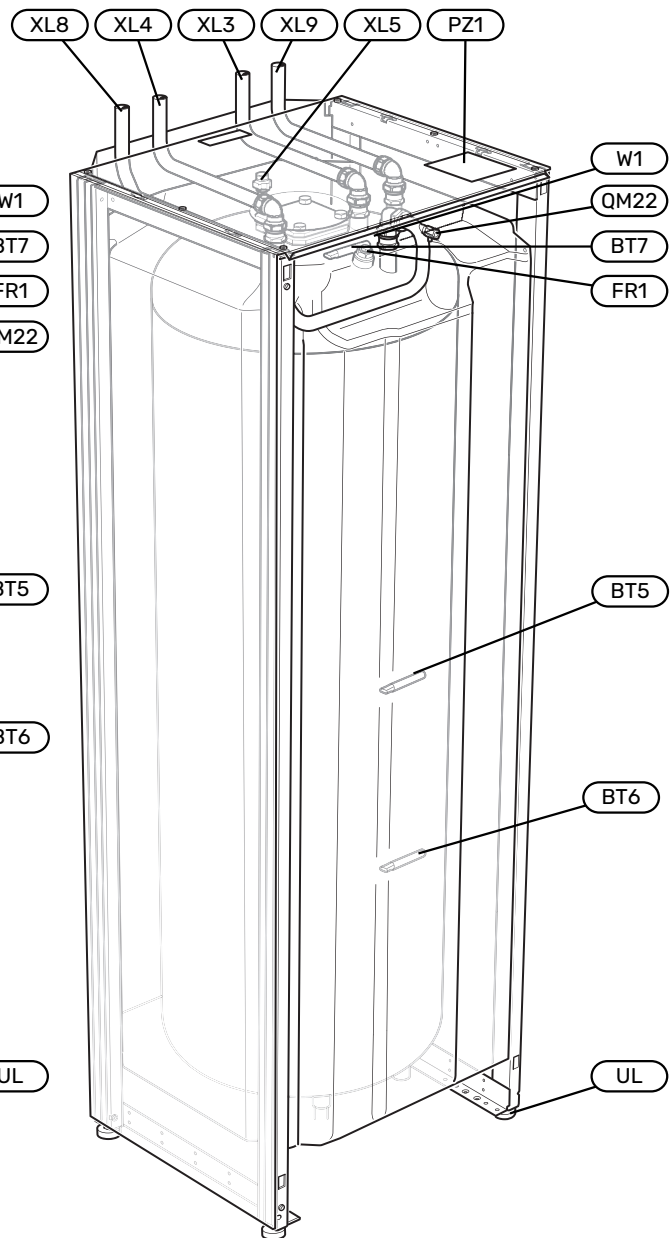

PIPE CONNECTIONS

- XL3 Cold water connection
- XL4 Hot water connection
- XL5 Connection, hot water circulation¹
- XL8 Docking connection, supply line (from heat pump)
- XL9 Docking connection, return line (to heat pump)

¹ Applies only to enamel and stainless steel.

HVAC COMPONENTS

- QM22 Venting, charge coil
- UA4 Submerged tube for control sensor for external heat source (BT54)

SENSORS

- BT5 Controlling hot water sensor
- BT6 Controlling hot water sensor
- BT7 Display hot water sensor

ELECTRICAL COMPONENTS

- FR1 Direct-current anode (NIBE VPB S enamel only)
- W1 Cable to direct-current anode (NIBE VPB S enamel only)

MISCELLANEOUS

- PZ1 Rating plate
- UL Adjustable feet

Designations according to standard EN 81346-2.

Pipe connections

GENERAL

Pipe installation must be carried out in accordance with current norms and directives.



NOTE!

Ensure that incoming water is clean. When using a private well, it may be necessary to supplement with an extra water filter.



CAUTION!

The pipe systems have to be flushed clean before the product is connected, to prevent any contaminants from damaging the components.



CAUTION!

Water may drip from the safety valve's overflow pipe. The overflow pipe must be routed to a suitable drain, to prevent hot water splashes from causing harm. The overflow pipe must be inclined along its entire length to prevent pockets where water can accumulate, and must be frost-proof. The overflow pipe must be at least the same size as the safety valve. The overflow pipe must be visible and its mouth must be open and not placed close to electrical components.

PIPE DIMENSIONS

VPB S200 / VPB S300

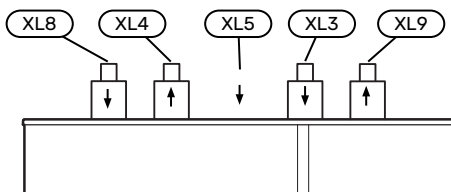

Connection			
XL3 Cold water \varnothing	mm	22	
XL4 Hot water \varnothing	mm	22	
XL5 Hot water circulation \varnothing	mm	15	
XL8 Docking connection, supply line \varnothing	mm	22	
XL9 Docking connection, return line \varnothing	mm	22	

SYMBOL KEY

Symbol	Meaning
	Unit box
	Shut-off valve
	Non-return valve
	Mixing valve
	Circulation pump
	Expansion vessel
	Filterball
	Pressure gauge

Symbol	Meaning
	Safety valve
	Temperature sensor
	Trim valve
	Domestic hot water
	Addition
	Hot water circulation
	Heat pump
	Heating system

SYSTEM DIAGRAM



CAUTION!

This is the outline diagram. Actual installations must be planned according to applicable standards.

NIBE VPB S is a series of water heaters that are suitable for connection to e.g. a heat pump.

Further information about the system principle is available at nibe.eu and in the manuals for the heat sources used.

VPB S200 / VPB S300

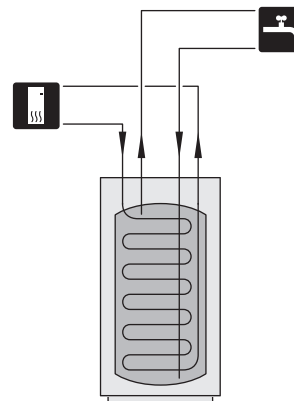

TO HEAT PUMP

NIBE VPB S may only be docked with a NIBE heat pump, for example NIBE S1156.

The heat pump's supply and return lines are connected to docking connection, supply (XL8) and docking connection, return (XL9) on NIBE VPB S.

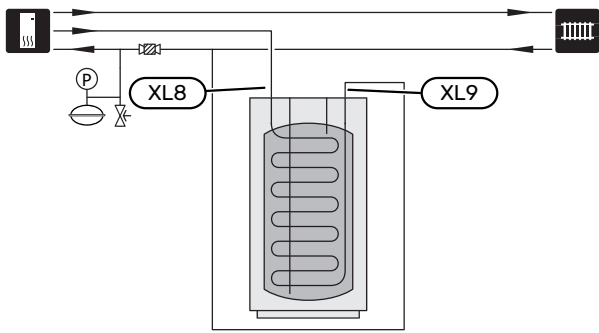

COLD AND HOT WATER

Connecting cold and hot water

Install as follows:

- shut-off valve
- non-return valve
- mixing valve

A mixer valve must also be installed, if the factory setting for hot water is changed. National regulations must be observed.

- pressure relief valve

The safety valve must have an opening pressure of max. 1.0 MPa (10.0 bar).

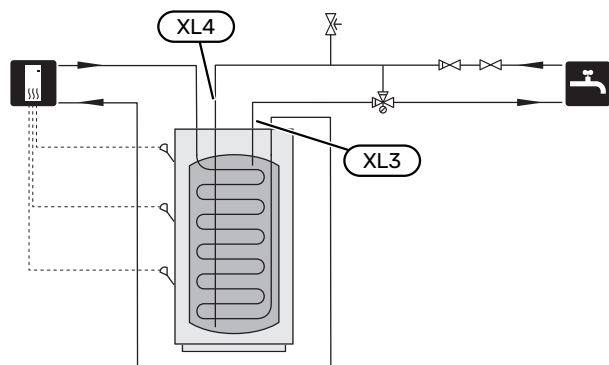

HOT WATER CIRCULATION (HWC)

A circulation pump can be controlled by the main product to circulate the hot water. The circulating water must have a temperature that prevents bacterial growth and scalding, and national standards must be met.

The HWC return is connected to the HWC connection (XL5).

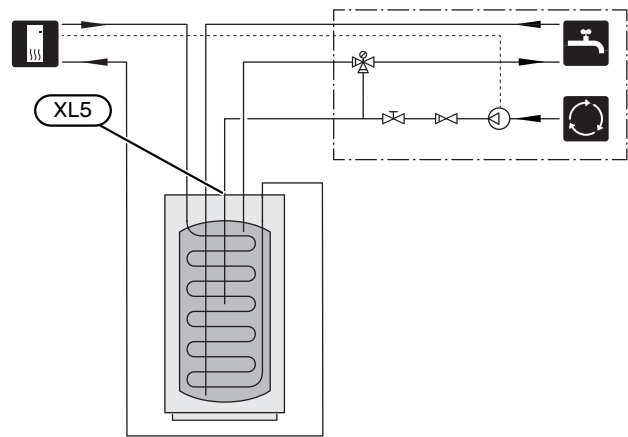

Electrical installation

GENERAL

Electrical installation and wiring must be carried out in accordance with national provisions.



CAUTION!

Electrical installation and any servicing must be carried out under the supervision of a qualified electrician. Turn off the power with the circuit breaker before servicing.

DIRECT-CURRENT ANODE

NIBE VPB S Enamel is equipped with direct-current anode and enclosed with potentiostat from the factory. The anode cable (W1) is installed in the anode from the factory and only needs to be connected to the potentiostat.

1. Route the anode cable (W1) along the docking pipe, supply line (XL8).
2. Connect the anode cable (W1) to the potentiostat.
3. Connect the potentiostat to a suitable 230 V wall socket.



CAUTION!

The cable between the potentiostat and the anode must either be extended or shortened.

The figure shows VPB S200 enamel

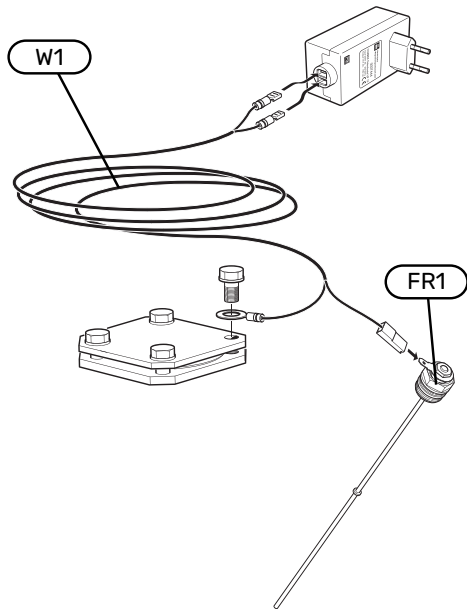
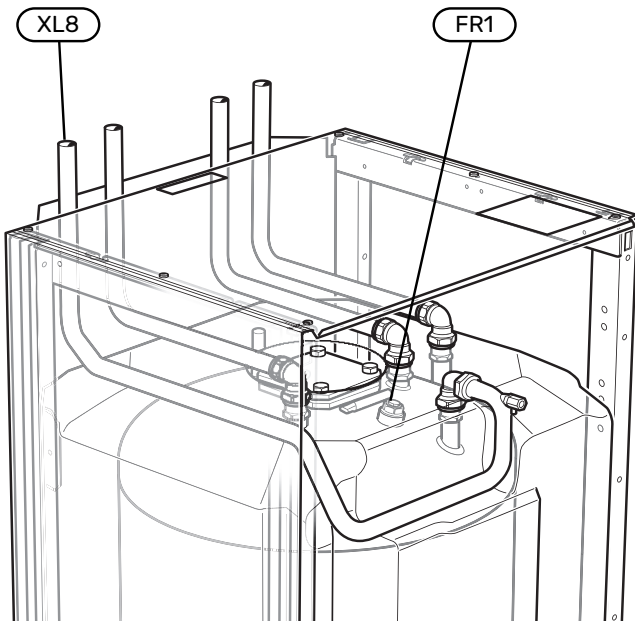

Commissioning and adjusting

FILLING AND VENTING

Filling the hot water heater

1. Open a hot water tap in the house.
2. Fill the hot water heater through the cold water connection (XL3).
3. When the water that comes out of the hot water tap is no longer mixed with air, the water heater is full and the hot water tap can be closed.

Topping up the charge coil

1. Open the externally mounted filling valve. Fill the coil in the hot water heater and the rest of the climate system with water.
2. Open the vent valve (QM22).
3. When the water that exits the vent valve (QM22) is not mixed with air, close the valve. After a while, the pressure starts to rise.
4. Close the filling valve when the correct pressure is obtained.

Venting the charge coil

1. Vent the coil via the vent valve (QM22) and the rest of the climate system via the relevant vent valves.
2. Keep topping up and venting until all air has been removed and the pressure is correct.

The figure shows VPB S200.

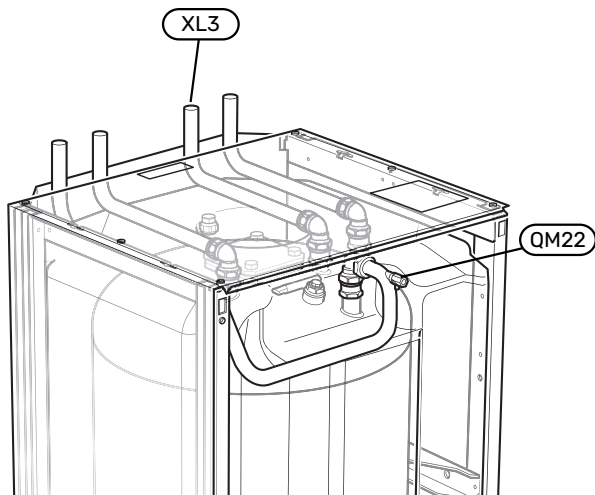

START-UP AND INSPECTION

Pressure drop diagram, charge coil

Docking connection, supply line (XL8) and docking connection, return line (XL9).

VPB S200

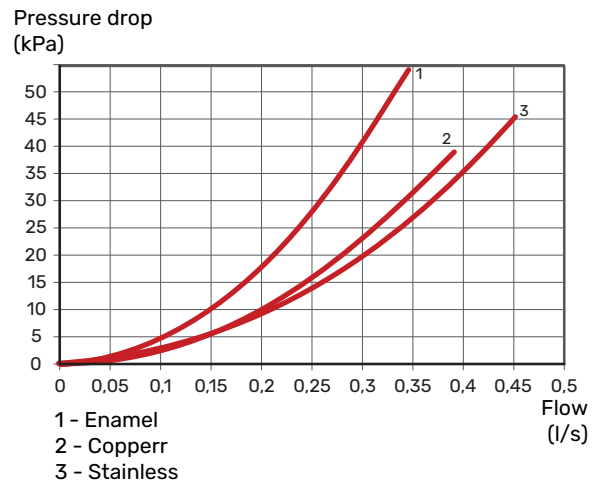

VPB S300

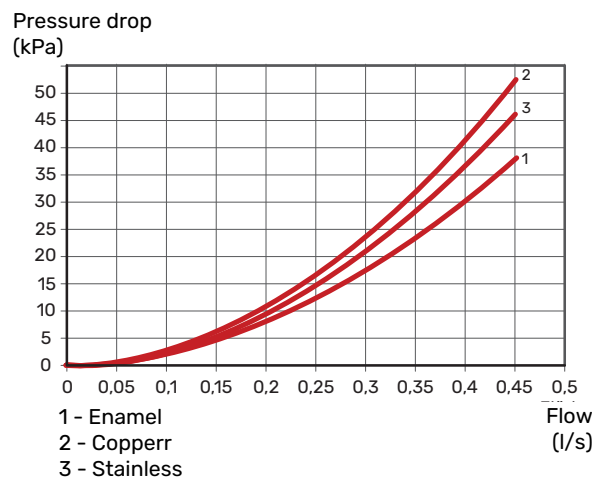

Technical data

Dimensions

VPB S200



VPB S300

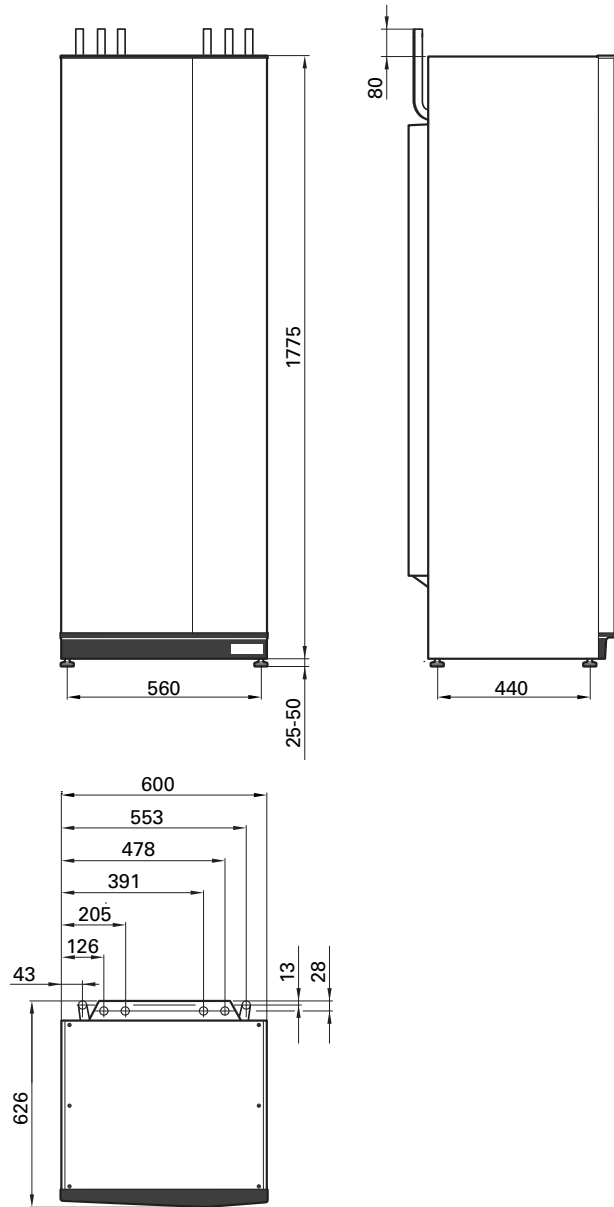

Technical specifications

VPB S200		Copper	Enamel	Stainless
Heating medium circuit				
Max pressure in the heating medium circuit	bar/MPa	0.3 (3)		
Pipe connections				
Hot water ext Ø	mm	22		
Cold water ext Ø	mm	22		
Hot water circulation ext Ø	mm	15		
Docking ext Ø	mm	22		
Hot water and heating section				
Volume coil	litre	2.0	4.8	7.8
Volume hot water heater	litre	178	178	176
Max operating temperature	°C	85		
Opening pressure, safety valve	MPa (bar)	1.0 (10)		
Heating time (10°C to 50°C) 8 kW charge power	h	1		
Equivalent amount of hot water (40 °C) ¹	litre	230	238	235
Dimensions and weight				
Width	mm	600		
Depth	mm	626		
Height	mm	1500		
Ceiling height	mm	1670 ²		
Weight	kg	101	111	80
Part No.		081 139	081 140	081 141
EPREL		248 646	248 647	248 648

¹ At incoming temperature 10 °C and a domestic water flow of 0.25 l/s.

² Med fötterna avmonterade blir reshöjden ca. 1650 mm.

VPB S300		Copper	Enamel	Stainless
Heating medium circuit				
Max pressure in the heating medium circuit	bar/MPa	0.3 (3)		
Pipe connections				
Hot water ext Ø	mm	22		
Cold water ext Ø	mm	22		
Hot water circulation ext Ø	mm	15		
Docking ext Ø	mm	22		
Hot water and heating section				
Volume coil	litre	2.0	8.4	8.8
Volume hot water heater	litre	278	274	282
Max operating temperature	°C	85		
Opening pressure, safety valve	MPa (bar)	1.0 (10)		
Heating time (10°C to 50°C) 8 kW charge power	h	1.5		
Equivalent amount of hot water (40 °C) ¹	litre	362	364	376
Dimensions and weight				
Width	mm	600		
Depth	mm	626		
Height	mm	1800		
Ceiling height	mm	1950 ²		
Weight	kg	130	143	101
Part No.		081 142	081 144	081 143
EPREL		248 649	248 651	248 650

¹ At incoming temperature 10 °C and a domestic water flow of 0.5 l/s.

² Med fötterna avmonterade blir reshöjden ca. 1930 mm.

Energy labelling

Supplier		NIBE		
Model		VPB S200 Cu/E/R	VPB S300 Cu/E/R	VPBS S300 Cu/E
Efficiency class ¹		C	C	C
Heat loss	W	66	88	95
Volume	l	178 / 178 / 176	278 / 274 / 282	277 / 270

¹ Scale for the product's efficiency class A+ to F.

Contact information

AUSTRIA

KNV Energietechnik GmbH
Gahberggasse 11, 4861 Schörfling
Tel: +43 (0)7662 8963-0
mail@knv.at
knv.at

FINLAND

NIBE Energy Systems Oy
Juurakkotie 3, 01510 Vantaa
Tel: +358 (0)9 274 6970
info@nibe.fi
nibe.fi

GREAT BRITAIN

NIBE Energy Systems Ltd
3C Broom Business Park,
Bridge Way, S41 9QG Chesterfield
Tel: +44 (0)330 311 2201
info@nibe.co.uk
nibe.co.uk

POLAND

NIBE-BIAWAR Sp. z o.o.
Al. Jana Pawla II 57, 15-703 Białystok
Tel: +48 (0)85 66 28 490
biawar.com.pl

CZECH REPUBLIC

Družstevní závody Dražice - strojírna
s.r.o.
Dražice 69, 29471 Benátky n. Jiz.
Tel: +420 326 373 801
nibe@nibe.cz
nibe.cz

FRANCE

NIBE Energy Systems France SAS
Zone industrielle RD 28
Rue du Pou du Ciel, 01600 Reyrieux
Tél: 04 74 00 92 92
info@nibe.fr
nibe.fr

NETHERLANDS

NIBE Energietechnik B.V.
Energieweg 31, 4906 CG Oosterhout
Tel: +31 (0)168 47 77 22
info@nibenl.nl
nibenl.nl

SWEDEN

NIBE Energy Systems
Box 14
Hannabadsvägen 5, 285 21 Markaryd
Tel: +46 (0)433-27 30 00
info@nibe.se
nibe.se

DENMARK

Vølund Varmeteknik A/S
Industrivej Nord 7B, 7400 Herning
Tel: +45 97 17 20 33
info@volundvt.dk
volundvt.dk

GERMANY

NIBE Systemtechnik GmbH
Am Reiherpfahl 3, 29223 Celle
Tel: +49 (0)5141 75 46 -0
info@nibe.de
nibe.de

NORWAY

ABK-Qviller AS
Brobekkeveien 80, 0582 Oslo
Tel: (+47) 23 17 05 20
post@abkqviller.no
nibe.no

SWITZERLAND

NIBE Wärmetechnik c/o ait Schweiz AG
Industriepark, CH-6246 Altishofen
Tel. +41 (0)58 252 21 00
info@nibe.ch
nibe.ch

For countries not mentioned in this list, contact NIBE Sweden or check nibe.eu for more information.

NIBE Energy Systems
Hannabadsvägen 5
Box 14
SE-285 21 Markaryd
info@nibe.se
nibe.eu

CHB EN 2512-4 531224

This is a publication from NIBE Energy Systems. All product illustrations, facts and data are based on the available information at the time of the publication's approval.

NIBE Energy Systems makes reservations for any factual or printing errors in this publication.

©2025 NIBE ENERGY SYSTEMS

