

NIBE MEGACOIL

Air to Water Heat Pump Domestic Hot Cylinders

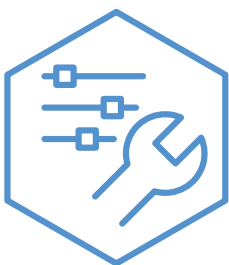

EN User and Installer manual

Table of Contents

1. Important information	4
Safety information	4
2. Delivery and handling	7
Transport	7
Assembly	7
Supplied components	7
3. The water heater design	8
4. Pipe connections	9
General	9
Dimensions and pipe connections	10
Overall dimensions	11
T&P valve	12
Heat pump	12
Horizontal	12
Cold and hot water	13
Docking	14
5. Electrical installation	16
Sensors	16
Temperature limiter	16
6. Commissioning and adjusting	18
Filling and venting	18
Start-up and inspection	18
7. Service and maintenance	20
Maintenance	20
Service actions	20
8. Technical specifications	21
Technical specification	21
Water chemistry	21
Item register	22

EN 12897:2016



1. Important information

Safety information

This manual describes installation and service procedures for implementation by specialists. This appliance is not intended for use by persons (including children) with reduced physical, sensory or mental capabilities, or lack of experience and knowledge, unless they have been given supervision or instruction concerning use of the appliance by a person responsible for their safety. Children should be supervised to ensure that they do not play with the appliance.

Rights to make any design or technical modifications are reserved.

©NIBE 2024

Country specific information

This user and installer manual must be left with the customer.

Great Britain

This installation is subject to building regulation approval, notify the local Authority of intention to install. Use only manufacturer's recommended replacement parts.

Symbols



Note

This symbol indicates danger to water heater or person.



Caution

This symbol indicates important information about what you should observe when maintaining your installation.



Tips

This symbol indicates tips on how to facilitate using the product.

Serial number

The serial number can be found on the rating plate below the front cover.



Caution

Always give the product's serial number when reporting a fault.



Recovery

Leave the disposal of the packaging to the installer who installed the product or to special waste stations. Do not dispose of used products with normal household waste. It must be disposed of at a special waste station or dealer who provides this type of service.

Improper disposal of the product by the user results in administrative penalties in accordance with current legislation.



Caution

When secondary return circuits are used, an additional expansion vessel may be required.

Warranty

Thank you for installing a new NIBE Megacoil. NIBE Megacoils are manufactured to the highest standard so NIBE are pleased to offer a comprehensive guarantee. The product is guaranteed for 24 months for parts and labour from the date of commissioning. The inner stainless steel vessel is guaranteed against material defect or manufacturing faults for a period of 25 years. The installer must complete and return the guarantee registration card, or completes the guarantee form on the NIBE website www.nibe.co.uk within 28 days from commissioning to activate this warranty.

The warranty is valid provided that:

The NIBE Megacoil has been correctly installed in accordance with our printed installation manual by a competent person and all relevant Codes, Best Practice and Regulations in existence at the time of installation have been adhered to.

Any disinfection of the cylinder has been carried out in accordance with BS6700.

The product has only been used for the storage of wholesome water (max.250mg/l chloride at 65 °C).

The installer has fully completed the Benchmark Checklist at the end of the Installation Manual supplied with the product.

The product is serviced annually by a competent person and the relevant Service Record on the Benchmark Checklist completed after each service. The completed Benchmark Checklist & Service Record may be required in the event of a warranty claim and as supporting documentation invoices relating to servicing may also be required.

The unit is registered within 28 days of commissioning via the guarantee form on the NIBE website www.nibe.co.uk or by completing the enclosed warranty card supplied with the product. Failure to do so may result in a reduced or invalid warranty period.

No factory fitted parts have been removed for unauthorised repair or replacement.
The unit has not been damaged by frost and/or freezing pipe work connected to the unit.

This guarantee does not confer any rights other than those expressly set out above and does not cover any claims for consequential loss or damage. This guarantee is offered as an extra benefit and does not affect your statutory rights as a consumer.



Benchmark places responsibilities on both manufacturers and installers. The purpose is to ensure that customers are provided with the correct equipment for their needs, that it is installed, commissioned and serviced in accordance with the manufacturers instructions by competent persons and that it meets the requirements of the appropriate Building Regulations.

The Benchmark Checklist can be used to demonstrate compliance with Building Regulations and should be provided to the customer for future reference. Installers are required to carry out the installation, commissioning and servicing work in accordance with the Benchmark Code of practice which is available from the Heating and Hotwater Industry Council who manage and promote the Scheme.

Please ensure that the installer has fully completed the Benchmark Checklist in the end of the Installation Instructions supplied with the product and that you have signed to say that you have received a full and clear explanation of its operation. The installer is legally required to complete a commissioning checklist as a means of complying with the appropriate Building Regulations (England and Wales).

All installations must be notified to Local Area Building Control either directly or through a Competent Persons Scheme. A Building Regulations Compliance Certificate will then be issued to the customer who should, on receipt, write the Notification Number on the Benchmark Checklist.

This product should be serviced regularly to optimise its safety, efficiency and performance. The service engineer should complete the relevant Service Record on the Benchmark Checklist after each service. The Benchmark Checklist may be required in the event of any warranty work and as supporting documentation relating to home improvements in the optional documents section of the Home Information Pack.

Inspection of the installation

Current regulations require the heating installation to be inspected before it is commissioned. The inspection must be carried out by a suitably qualified person.

✓	Description	Notes	Signature	Date
Hot water (page 14)				
	Shut-off valves			
	Expansion vessel			
	T&P valve			
	Tundish			
Cold water (page 13 and 14)				
	Shut-off valves			
	Non-return valve			
	Mixing valve			
	Safety valve			
	Tundish			
Electricity (page 16)				
	Hot water sensor			
	Temperature limiter			
Miscellaneous				
	Benchmark checklist			

2. Delivery and handling

Transport

The Megacoil should be transported and stored vertically in a dry place.

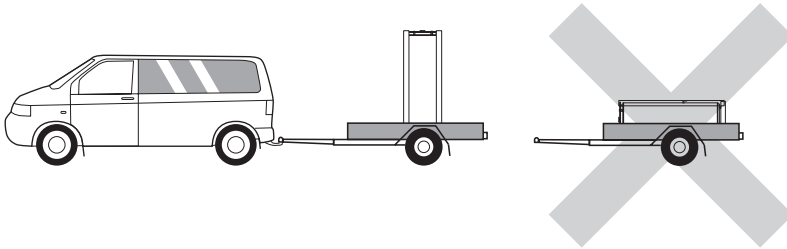

Assembly

- The water heater is only designed for upright installation.
- Position the water heater on a base that can bear its weight, preferably on a concrete floor or foundation. Use the water heater's adjustable feet to obtain a horizontal and stable set-up.
- Pipes must be routed from the safety valve to a suitable drain.
- The water heater's installation area should always have a temperature of at least 10 °C and max 30 °C.
- Remember to rotate the cylinder in a direction that allows easy access to the immersion heater and the electrical box.
- The NIBE Mega coil cylinder can only be installed with a heat pump. The cylinder can be installed without a 2-port safety valve & high limit stat if the heat pump contains a factory fitted, non self-resetting high pressure switch. The High Pressure switch needs to cut out at maximum 80 °C and the heat pump must be CE marked to show compliance with the latest safety regulations and standards.
- Additional expansion vessels may be required where secondary return circuits may be used.

Supplied components



Elbow and drain cock - cold inlet



Tundish



Armoured hose (expansion vessel)



Expansion vessel with holder



Cold water inlet combination (Pressure reduction valve, check valve and expansion relief valve)



Installer manual

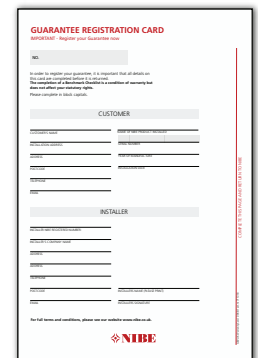

Warranty card

Location

The kit of supplied items comes in a separate box.

3. The water heater design

(See page 8 for explanations)

NIBE MEGACOIL 160, 200 and 300

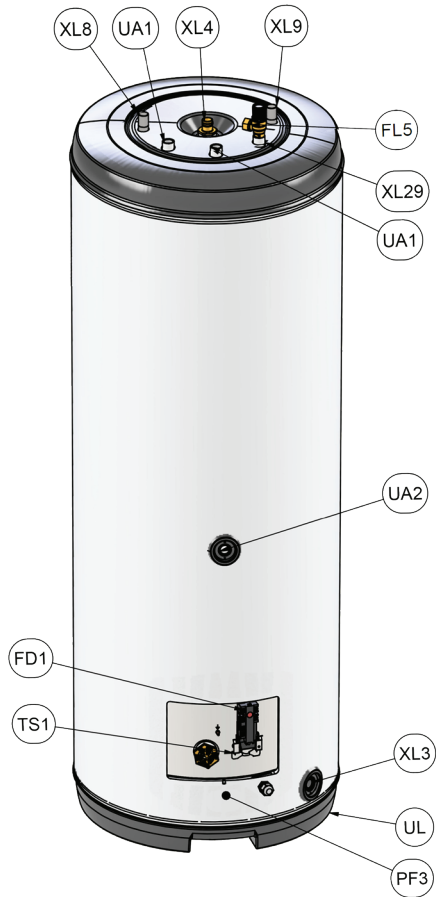

NIBE MEGACOIL 400

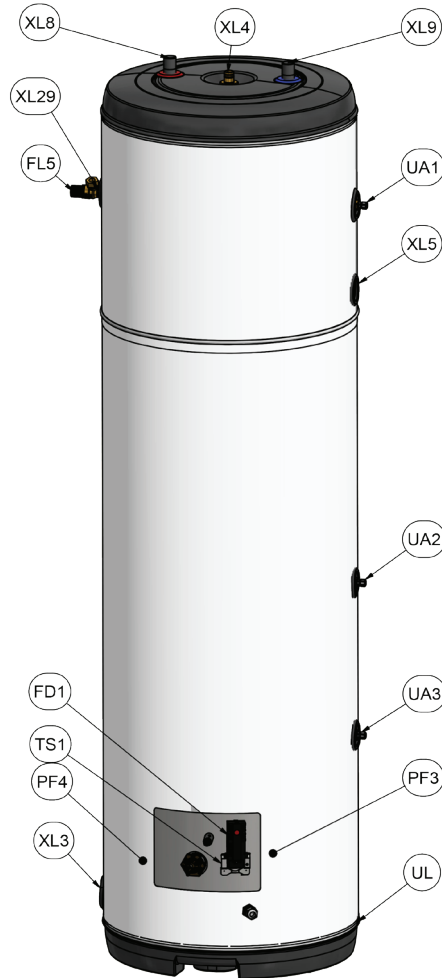

NIBE MEGACOIL Horizontal

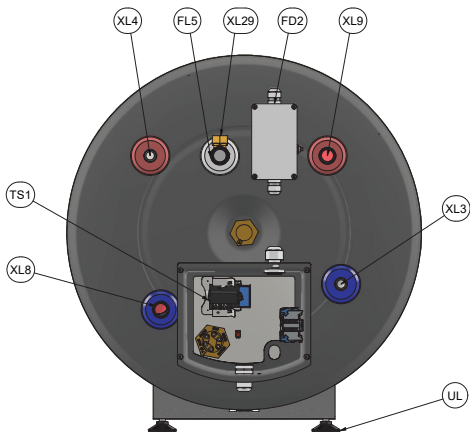

Pipe connections

XL3	Connection, cold water Ø 22 mm Horizontal/ 3/4" Vertical
XL4	Connection, hot water, Ø 22 mm
XL5	Connection, hot water circulation, Ø 1/2" (Not Megacoil 160 L.)
XL8	Docking connection, flow line (from heat pump), Ø22 mm
XL9	Docking connection, return line (to heat pump, Ø22 mm
XL29	Connection, T&P valve, Ø 15 mm

HVAC components

FL5	T&P valve Ø 15 mm
QM22	Venting, charge coil
UA 1	Submerged tube for hot water sensor (display)
UA2	Submerged tube for hot water sensor (control)

Electrical components

FDI	Temperature limiter immersion heater
FD2	Temperature limiter immersion heater Horizontal
TSI	Working thermostat immersion heater

Miscellaneous

PF 3	Serial number plate
PF4	Product/type plate
UL	Adjustable feet

Designations in component locations according to standard IEC 81346-1 and 81346-2.

EN 12897:2016

Cleaning the climate system

When the water heater and the climate system have been filled with water, the Megacoil must operate at maximum normal temperature for at least one hour. Thereafter the system must be drained of water and refilled.

4. Pipe connections

General

Pipe installation must be carried out in accordance with current norms and directives.

Internal support bushes should be fitted when a plastic pipe or annealed copper pipe is used. The water heater must be fitted with the requisite valves, such as a safety valve, shut-off valve, non-return valve, and vacuum valve. An overflow pipe must be routed from the safety valve to a suitable drain. The size of the overflow pipe must be the same as on the safety valve. Route the overflow pipe from the safety valve enclosed along its entire length and ensure that it is frost proof. The outlet of the overflow pipe should be visible and clearly away from any electrical components.

Overflow water from the safety valves goes via non-pressurised collecting pipes to a drain so that hot water splashes cannot cause injury. These non-pressurised collecting pipes must not be used for anything else. A discharge pipe from the tundish connected to the expansion relief valve (safety valve) must also be connected to a drain in the same way.

Please note that the connection of the T&P-valve should not be used for any other purpose.

Valves may not be positioned between the expansion valve and the vessel.

Discharge pipes from tundishes must have a vertical section of pipe at least 300 mm long, before any elbows or bends in the pipework (see following picture).

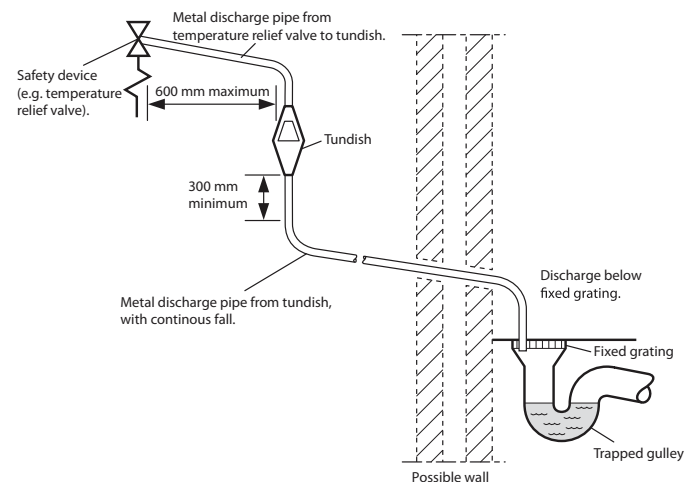

NOTE!

The expansion vessel accommodates expansion that results from heating the water inside the unit.

The expansion vessel must be connected between the expansion valve and the cylinder. The location of the expansion vessel should allow access to recharge the pressure as and when necessary.

The tundish must be installed away from electrical devices.

Valve outlet size	Minimum size of discharge pipe	Minimum size of discharge pipe from tundish	Maximum resistance allowed, expressed as a length of straight pipe (i.e. no elbows or bends)	Resistance created by each elbow or bend
G1/2	15 mm	22 mm	up to 9 m	0,8 mm
G1/2	15 mm	28 mm	up to 18 m	1,0 mm
G1/2	15 mm	35 mm	up to 27 m	1,4 mm
G3/4	22 mm	28 mm	up to 9 m	1,0 mm
G3/4	22 mm	35 mm	up to 18 m	1,4 mm
G3/4	22 mm	42 mm	up to 27 m	1,7 mm
G1	28 mm	35 mm	up to 9 m	1,4 mm
G1	28 mm	42 mm	up to 18 m	1,7 mm
G1	28 mm	54 mm	up to 27 m	2,3 mm

Hard water areas

Usually, there should not be a problem in installing Megacoil in areas of hard water as the operating temperature is 50-60 °C.

Emptying the system:

1. Close the main water supply.
2. Flush the system for some minute. Watch out for water splashes from the safety valve.
3. Close the valves and check the strainer.

Dimensions, pipe connections and setting-out coordinates

NIBE MEGACOIL 160, 200 and 300

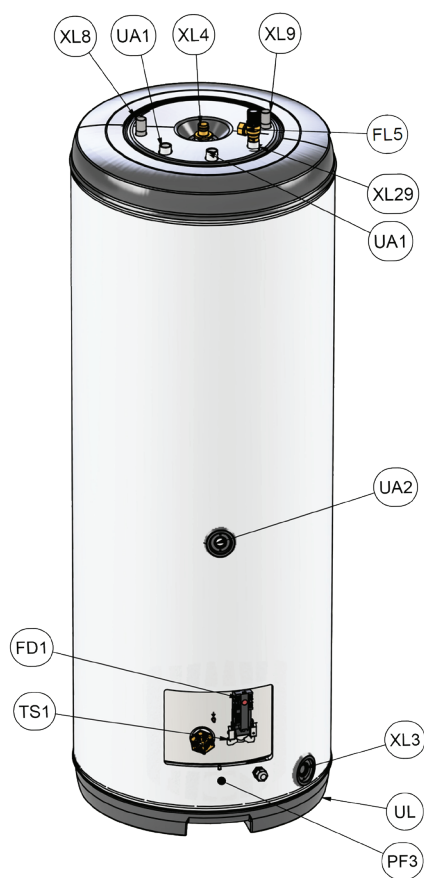

NIBE MEGACOIL 400

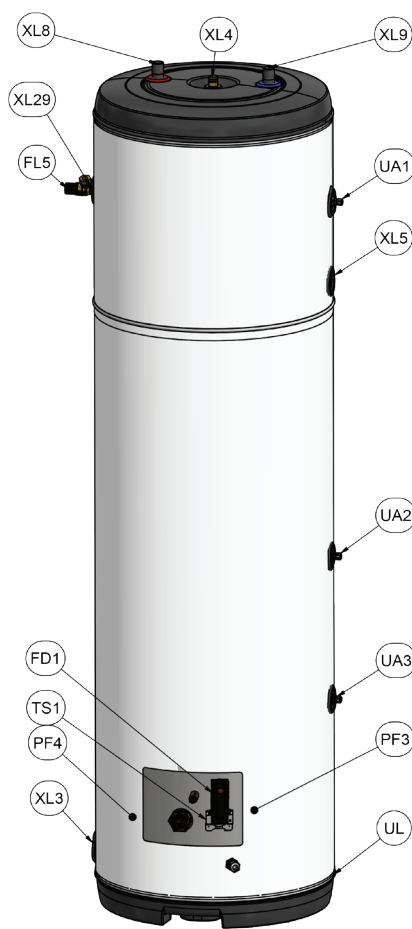

Connection	mm	inch
XL3 Cold water (160, 200, 300, 400)		3/4
XL3 Cold water (Horizontal 300)	22	
XL4 Hot water	22	
XL5 Hot water circulation		1/2
XL8 Docking connection, flow line	22	
XL9 Docking connection, return line	22	
XL29 T&P valve		1/2

NIBE MEGACOIL Horizontal

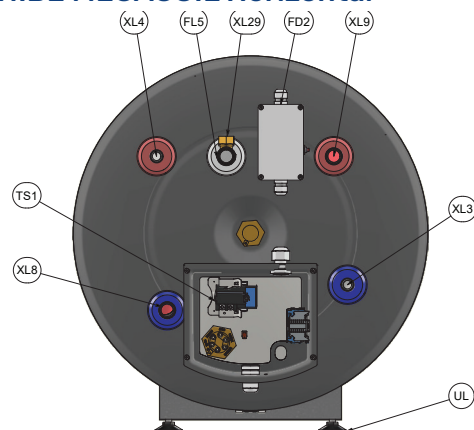

NIBE MEGACOIL

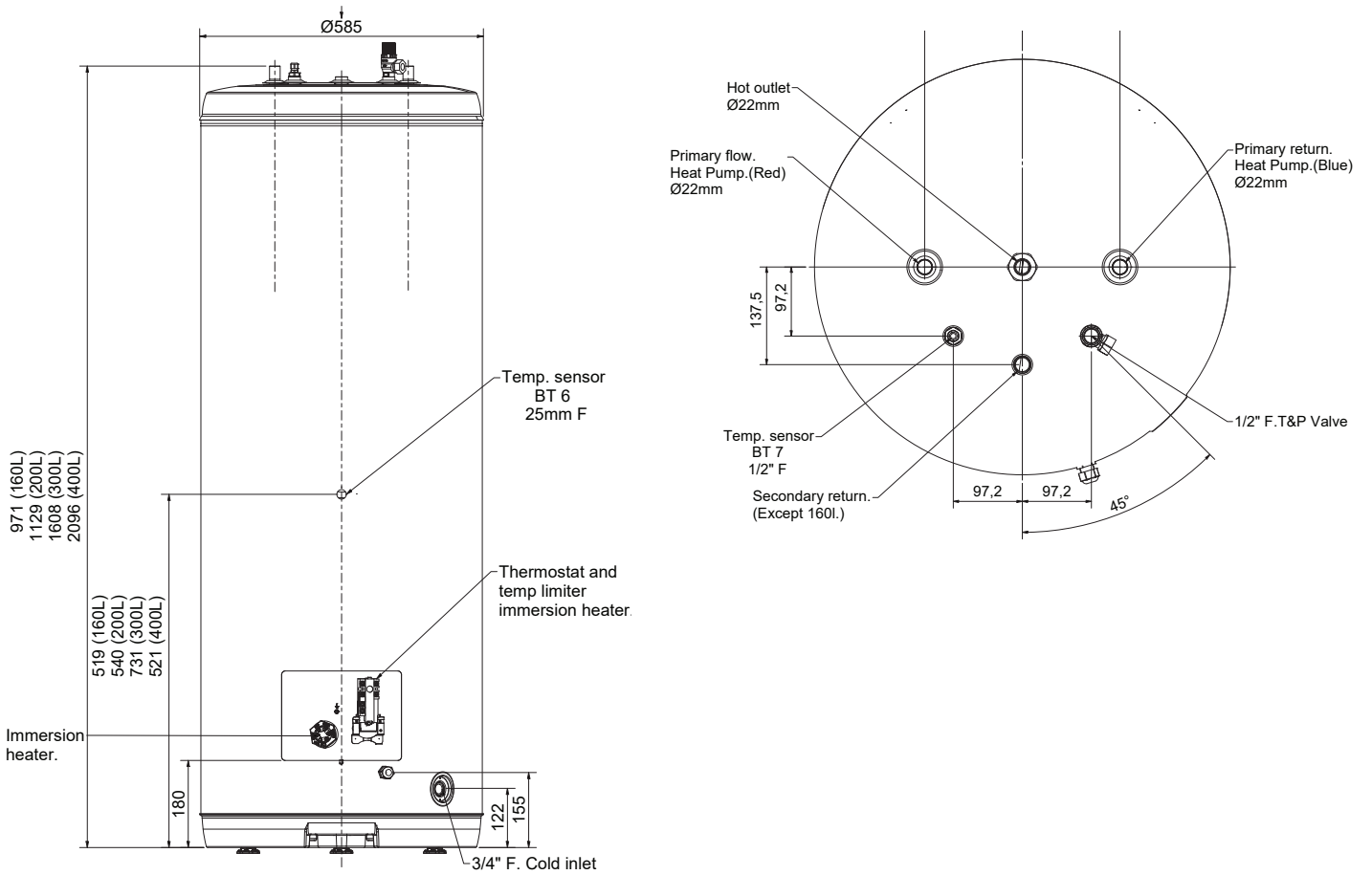

NIBE MEGACOIL Horizontal

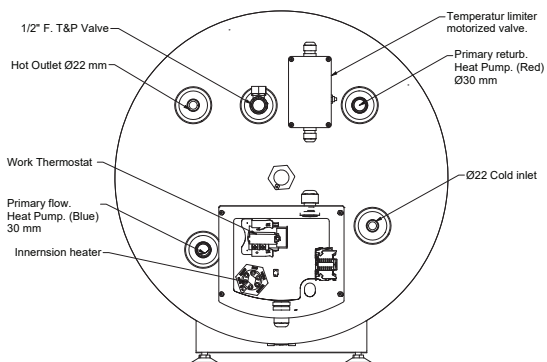
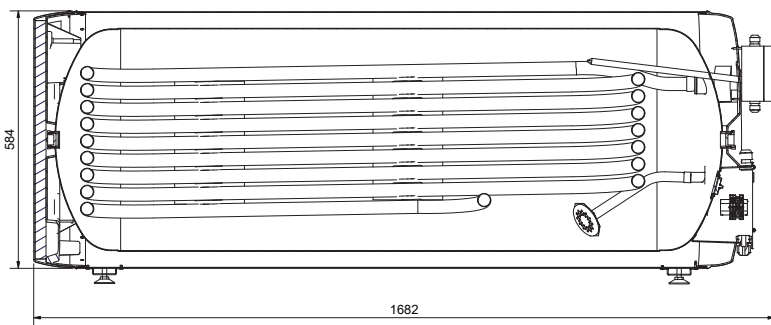

Heat pump connection

Horizontal

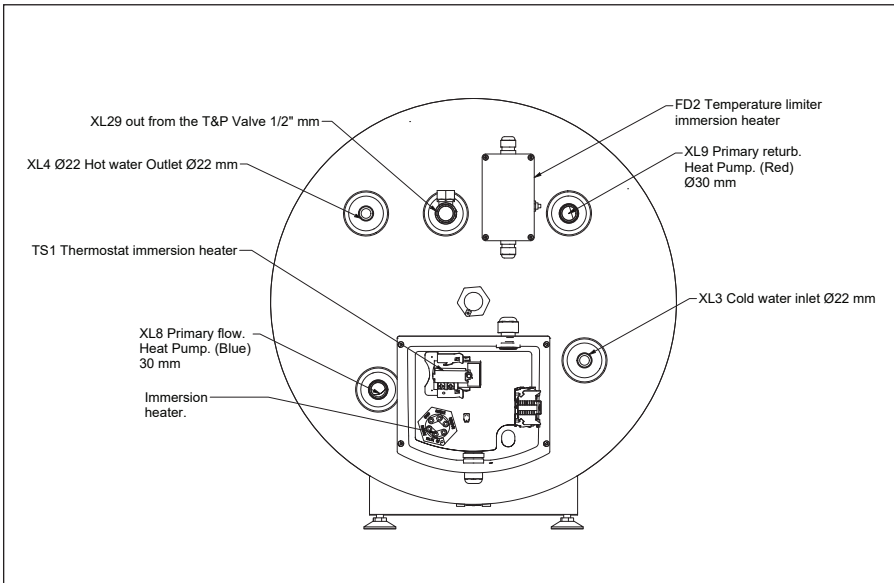

Connecting to heat pump

The heat pump supply and return are connected to the NIBE MEGACOIL.

Vertical

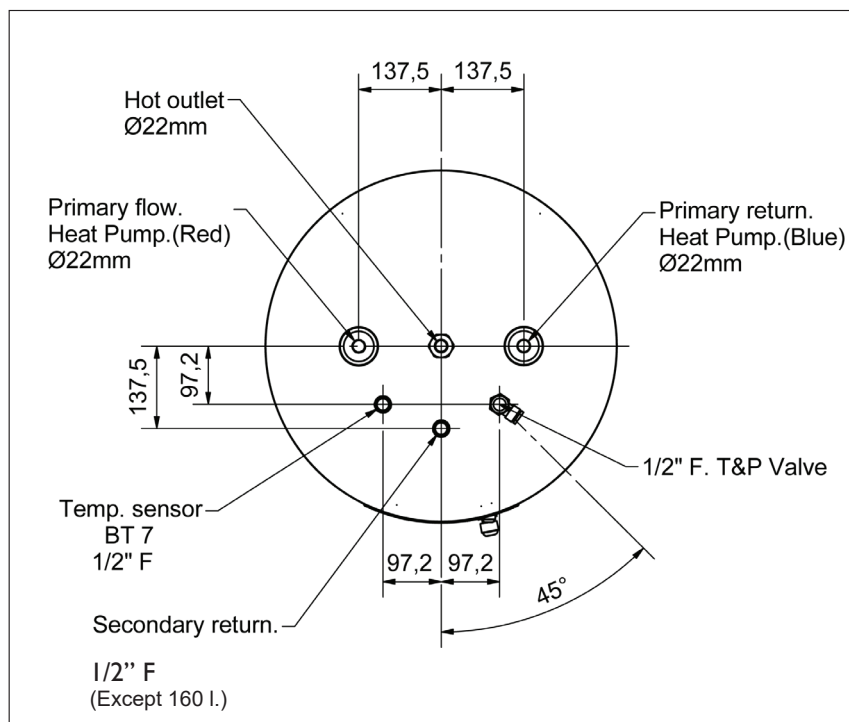

Cold and hot water

Connecting cold and hot water

There must be a mixing valve if the temperature can exceed 60 °C.
The flexible hose to the expansion vessel can be installed in the plugged connection on the safety valve.

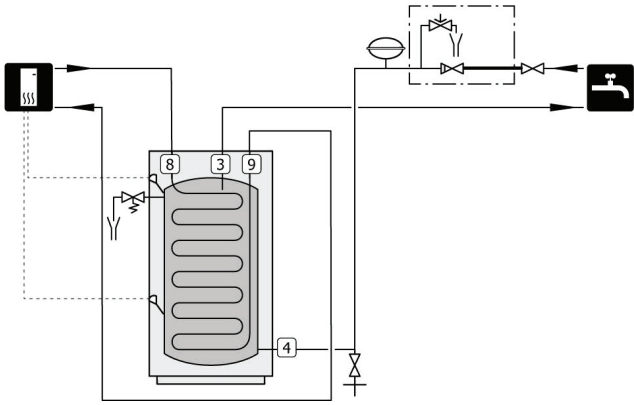

Docking

NIBE MEGACOIL can be connected in several ways, one of which is shown here.

Information on further options is available at www.nibe.co.uk and in the respective assembly instructions for the heat pumps used.

Symbol key

Symbol	Meaning
↑	Venting valve
∩	Shut-off valve
∩	Non-return valve
∩	Mixing valve
∩	Safety valve
∩	T&P valve
∩	Tundish
∩	Temperature sensor
∩	Circulation pump
∩	Particle filter
∩	Pressure reduction valve

Connecting hot water circulation

NIBE MEGACOIL 200, 300 and 400 have a connection that allows hot water circulation.

To reduce the risk of bacterial growth in systems with hot water circulation, the temperature of the circulating water should not fall below 50 °C. There should not be any non-circulatory hot water pipes. Adjust the hot water system so that the temperature does not fall below 50°C at the ends of the system.

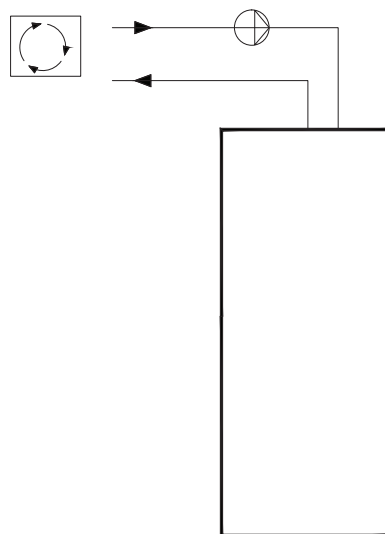

To air source heat pump

NIBE MEGACOIL can be docked with a Nibe air to water heat pump.

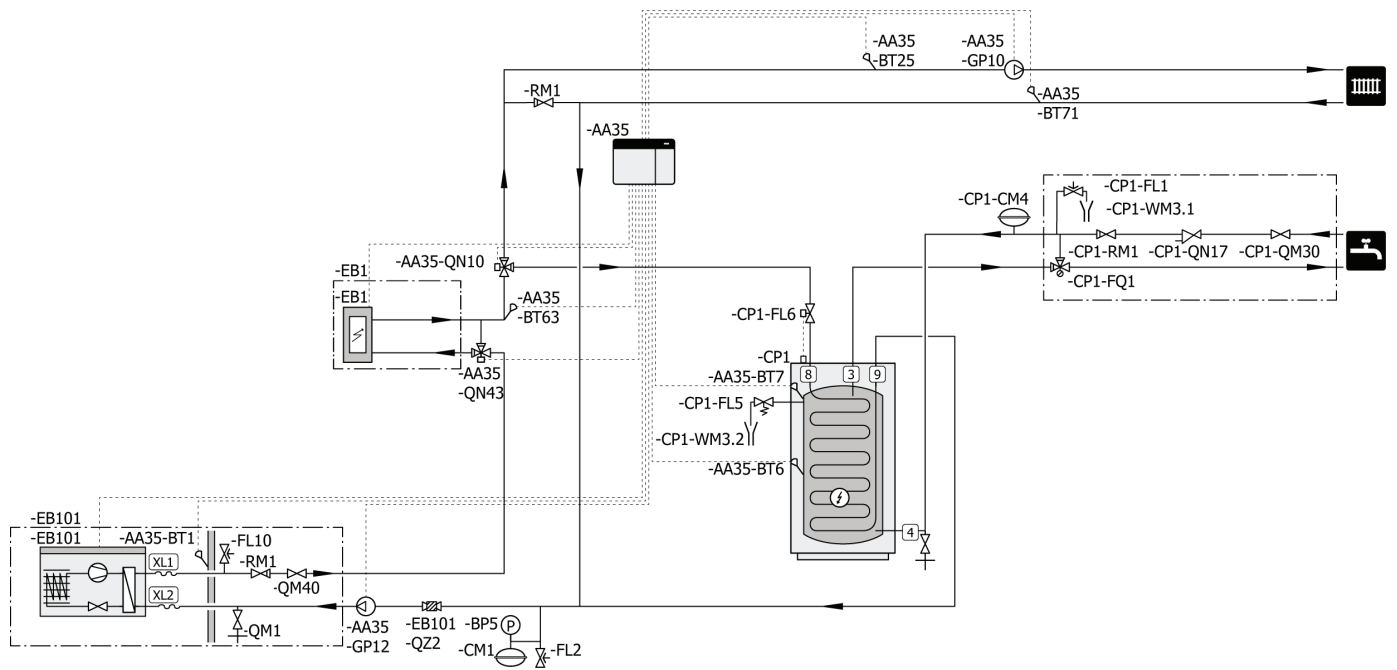

5. Electrical installation



NOTE

Electrical installation and service must be carried out under the supervision of a qualified electrician. Electrical installation and wiring must be carried out in accordance with the stipulations in force.

Sensors

(See page 10)

NIBE MEGACOIL can accommodate up to two hot water sensors, one for SMO Controller display and one to control start and stop of heat pump.

The display sensor is positioned in the submerged tube for the display sensor (UA1) and the control sensor in the submerged tube for control sensor (UA2). In cases where it is only possible to connect one sensor, use the submerged tube for control sensor (UA2).

Use the sensors provided with the heat pump/control module. When no heat sensors have been provided, these must be ordered from the manufacturer of the heatpump/control module.

Thermostats and temperature limiter

(Factory fitted)

NIBE MEGACOIL HORIZONTAL 300

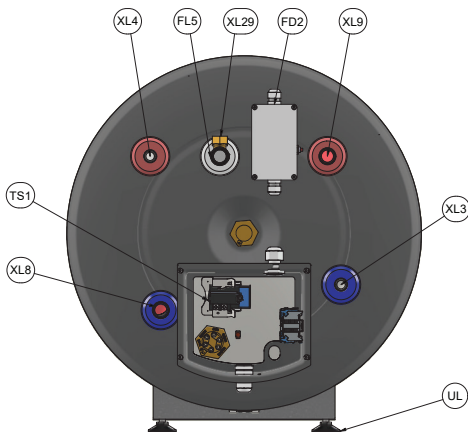

NIBE MEGACOIL 160, 200, 300 & 400

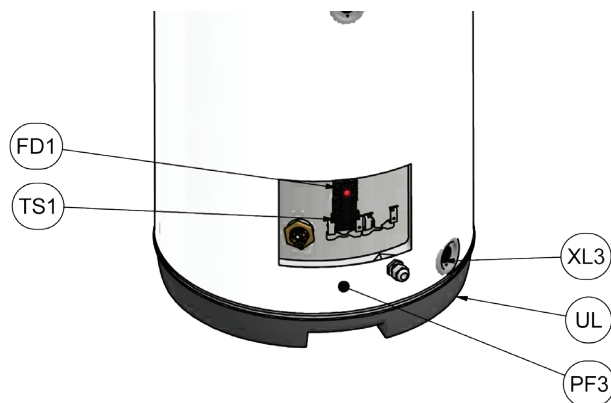

Temperature limiters

Power supply to temperature limiter (FD1) is 230 V. Connect temperature limiter (FD2) electrically to the motorized valves - one to each heat source.

NIBE MEGACOIL HORIZONTAL 300

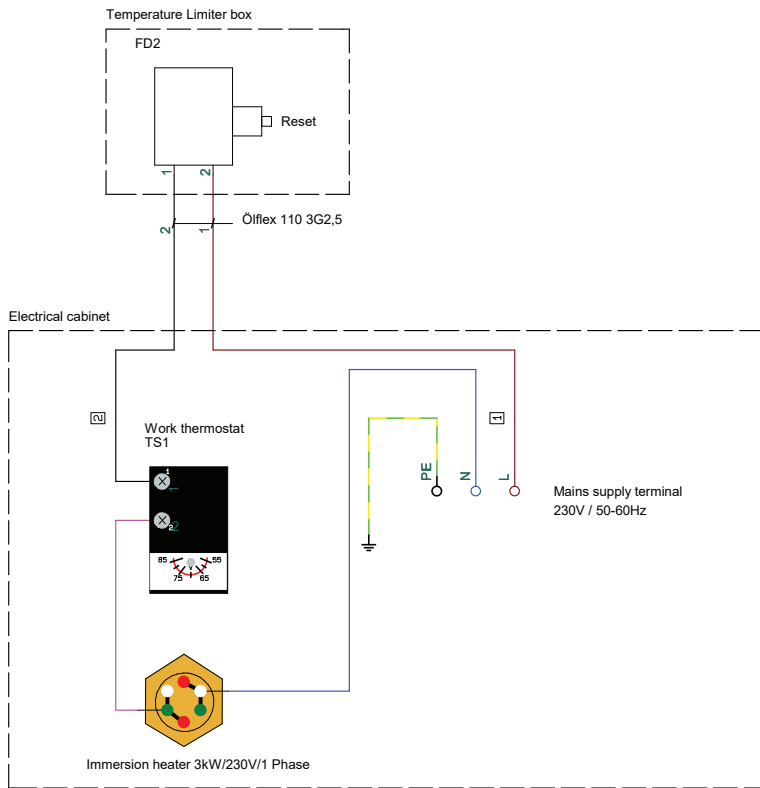

NIBE MEGACOIL 160, 200, 300 & 400

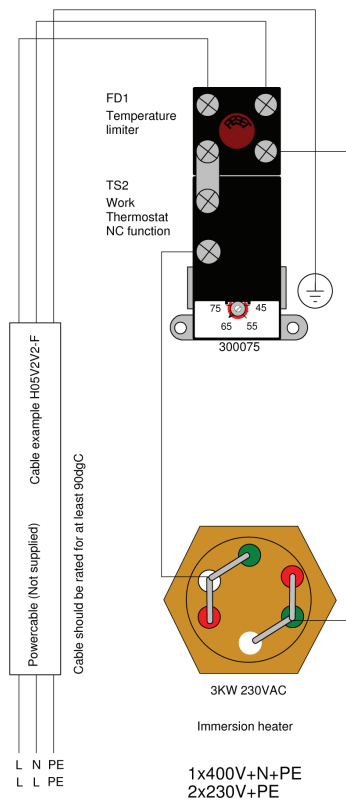

6. Commissioning and adjusting



NOTE

At the time of commissioning, complete all relevant sections of the Benchmark Checklist located at the back of this document.

Completion of the Benchmark Checklist is a condition of warranty. For full terms and conditions of warranty, please see our website www.nibe.co.uk.

Filling and venting the charge coil

Filling and venting

1. Open the filling valve (external, not included with the product). Fill the coil in the hot water heater and the rest of the climate system with water.
2. Vent the coil and the rest of the climate system via the relevant venting valves.
3. Keep topping up and venting until all air has been removed and the pressure is correct.

Filling and venting

Filling the hot water heater

1. Open a hot water tap in the house. (XL4)
2. Fill the hot water heater through the cold water connection (XL3).
3. When the water that comes out of the hot water tap is no longer mixed with air, the water heater is full. Flush the system for several minutes and the tap can be closed.

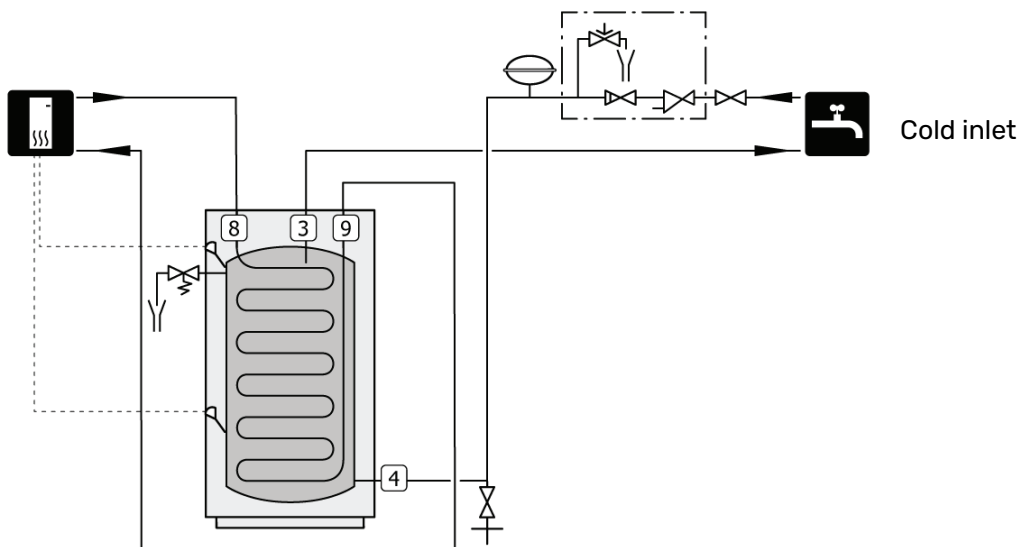

Pressure drop diagram

Pressure drop diagram, charge coil, horizontal coil
Docking connection, flow line (XL8) and
docking connection, return line (XL9).

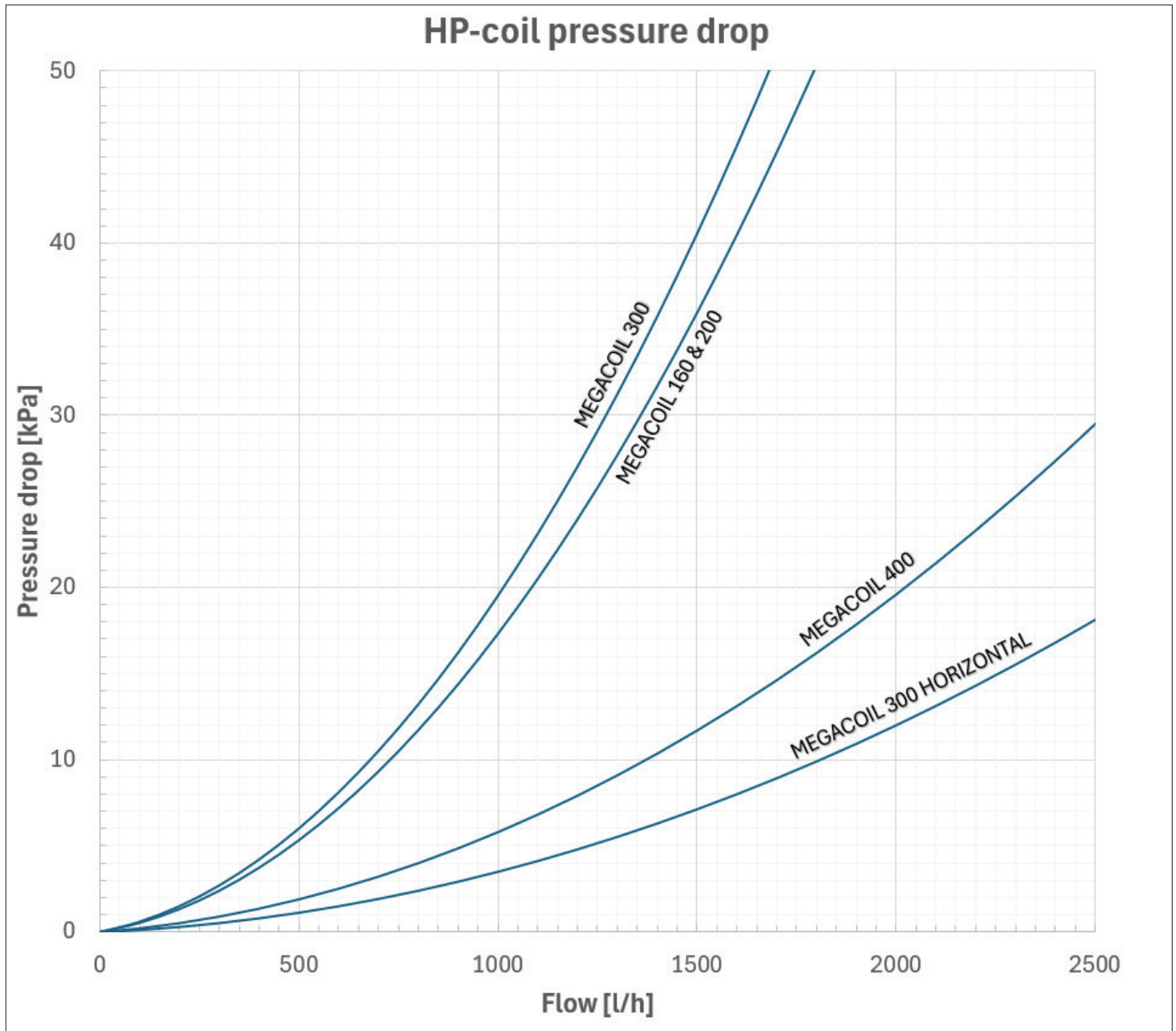

7. Service and maintenance



NOTE

After servicing, complete the relevant Service Interval Record section of the Benchmark Checklist located at the back of this document.

Completion of the Service Interval Record is a condition of warranty. For full terms and conditions of warranty, please see our website www.nibe.co.uk.



NOTE

Any servicing must be carried out by a competent person.



NOTE

If this pressurised water heater develops a fault, e.g. a flow of hot water from the overflow pipe, turn the heat pump off and contact your Installer.

Maintenance

General inspection

Check the following:

1. Condition of casing
2. Electrical connections
3. Pipe connections

Correct any fault before continuing.

Hot water heater

Check the following:

1. Expansion relief valve
2. T&P valve
3. Discharge pipe
4. Expansion vessel

Correct any fault before continuing.

Service actions

Safety valves

The function of the safety valves must be checked regularly.

Perform checks as follows:

1. Open the valve by turning the knob anti-clockwise carefully.
2. Check that water flows through the valve.
3. Close the valve by releasing it. If it does not close automatically when released, turn it anti-clockwise slightly.

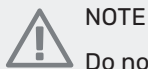

NOTE

Do not remove or adjust any components that are part of this pressurised water heater. Contact your installer!

Cleaning

Inspect and clean the water heater by using a suitable instrument such as an endoscope.

The hot water connection (XL4) must be removed to facilitate access.

Emptying

The water heater is emptied through the drain cock (with hose connection) in the cold water connection (XL3).

Drain the charge coil through the siphon (with hose) on the docking connection, return to heat pump (XL9).

NIBE MEGACOIL HORIZONTAL 300

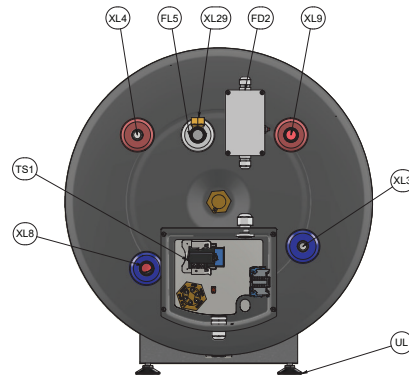

NIBE MEGACOIL 160, 200, 300 and 400

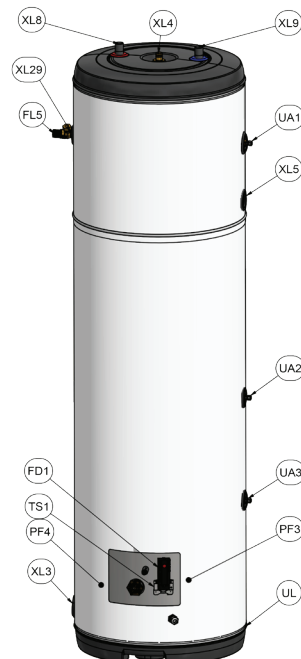

8. Technical specifications

NIBE MEGACOIL		160	200	300	400	Horizontal 300
Volume (net)	litre	143	179	271	346	261
Volume, charge coil	litre	8,1	8,5	10,6	26,5	18
Net weight	kg	42	45	59	84,2	65,6
Gross weight	kg	191	224	330	439	311
Heat content at 50°C	kWh	6,58	8,30	12,57	16,04	12,10
Amount of hot water (40°C) by 60°C	litre	198	234	361	449	237
Heating time (10°C to 60°C) at 80°C supply temperature	min.	10	50	91	26	19
Max operating temperature	°C	80	80	80	80	75
Max pressure, primary side	bar/MPa	3/0,3	3/0,3	3/0,3	3/0,3	3/0,3
Max pressure, water heater	bar/MPa	5,5/0,55	5,5/0,55	5,5/0,55	5,5/0,55	5,5/0,55
Max water supply pressure	bar/MPa	16/1,6	16/1,6	16/1,6	16/1,6	16/1,6
Exp. vessel, tap water, charge pressure	bar/MPa	3,0/0,3	3,0/0,3	3,0/0,3	3/0,3	3/0,3
Expansion relief valve, setting	bar/MPa	6/0,6	6/0,6	6/0,6	6/0,6	6/0,6
Max operating pressure, T&P-valve	bar/MPa	7/0,07	7/0,07	7/0,07	7/0,7	7/0,7
Max operating temperature, T&P-valve	°C	85	85	85	85	75
Heat loss at 45°C	kW/24h	1,24	1,62	2,01	2,39	2,11
Set pressure reducing valve	bar/MPa	3	3	3	3	3
Max temperature heat pump	°C	75	75	75	75	75
Max recommended NIBE heat pump	-	S2125-12 F2050-10	S2125-12 F2050-10	S2125-16 F2050-12	S2125-20 F2050-16	S2125-12 F2050-10
Volume expansion vessel	litre	18	18	24	24	24
Max design Pressure	bar/MPa	6	6	6	6	6
Corrosion protection	Material	Stainless steel	Stainless steel	Stainless steel	Stainless steel	Stainless steel
Part No.	-	081266	081267	081268	081259	081264
Eprel No.	-	2174658	2174660	2174665	2174667	2217950

Water chemistry

Total dissolved solids	-
Total Hardness	3 – 6 dH°
Chloride	200 mg Cl/l
Magnesium	10 mg Mg/l
Calcium	25 mg Ca /l,
Natriumchloride (Salt)	200 mg NaCl/l corresponds to (80 mg Na/l)
Sodium	100 mg Na/l. (ref. Norwegian drinking water regulations)
Iron	0,2 mg Fe/l (ref. Norwegian drinking water regulations)
Kobber	2,0 mg Cu/l (ref. Norwegian drinking water regulations)
pH minimum	6,5
pH maximum	9,5

The limit value for conductivity is 250 milliSiemens (mS/m) at 20°C.

9. Item register

A

Assembly, 6

C

Cold and hot water, 13

Commissioning and adjusting, 17

 Filling and venting, 17

 Pressure drop diagram, solar coil, 18

 Start-up and inspection, 19

Connecting cold and hot water, 13

Connecting hot water circulation, 13

Connecting to heat pump, 12

D

Delivery and handling, 6

 Assembly, 6

 Supplied components, 6

 Transport, 6

Dimensions and pipe connections, 10

Dimensions and setting-out coordinates, 10

E

Electrical installation, 15

 Sensors, 15

 Temperature limiter, 16

Emptying, 19

F

Filling and venting, 17

 Filling and venting the charge coil, 17

 Filling the hot water heater, 17

G

General inspection, 19

H

Heat pump, 12

 Connecting hot water circulation, 13

 Connecting to heat pump, 12

I

Important information, 4

 Safety information, 4

Inspection of the installation, 5

Installation alternative, 13

 To ground source heat pump, 14

M

Maintenance, 19

 General inspection, 19

P

Pipe connections, 9

 Cleaning the climate system, 8

 Cold and hot water, 13

 Connecting cold and hot water, 13

 Dimensions and pipe connections, 10

 General, 9

 Hard water areas, 9

 Heat pump, 12

 Installation alternative, 13

 Sun, 12

 Symbol key, 13

Pressure drop diagram, charge coil, 18

S

Safety information, 4

 Inspection of the installation, 5

 Serial number, 4

 Symbols, 4

 Warranty information, 4

Safety valves, 19

Sensors, 15

Serial number, 4

Service actions, 19

 Emptying, 19

 Safety valves, 19

Service and maintenance, 19

 Maintenance, 19

 Service actions, 19

Start-up and inspection, 19

Pressure drop diagram, charge coil, 18

Supplied components, 6

Symbol key, 13

Symbols, 4

T

Technical data, 20-21

 Dimensions and setting-out coordinates, 10

Temperature limiter, 16

The water heater design, 7

 List of components, 8

Transport, 6

W

Warranty information, 4

Water chemistry, 20

MAINS PRESSURE HOT WATER STORAGE SYSTEM COMMISSIONING CHECKLIST

This Commissioning Checklist is to be completed in full by the competent person who commissioned the storage system as a means of demonstrating compliance with the appropriate Building Regulations and then handed to the customer to keep for future reference.

Failure to install and commission this equipment to the manufacturer's instructions may invalidate the warranty but does not affect statutory rights.

Customer Name _____ Telephone Number _____
Address _____
Cylinder Make and Model _____
Cylinder Serial Number _____
Commissioned by (print name) _____ Registered Operative ID Number _____
Company Name _____ Telephone Number _____
Company Address _____ Commissioning Date _____

To be completed by the customer on receipt of a Building Regulations Compliance Certificate *: _____
Building Regulations Notification Number (if applicable) _____

ALL SYSTEMS PRIMARY SETTINGS (indirect heating only)

Is the primary circuit a sealed or open vented system? Sealed Open
What is the maximum primary flow temperature? _____ °C

ALL SYSTEMS

What is the incoming static cold water pressure at the inlet to the system? _____ bar
Has a strainer been cleaned of installation debris (if fitted)? Yes No
Is the installation in a hard water area (above 200ppm)? Yes No
If yes, has a water scale reducer been fitted? Yes No
What type of scale reducer has been fitted? _____
What is the hot water thermostat set temperature? _____ °C
What is the maximum hot water flow rate at set thermostat temperature (measured at high flow outlet)? _____ l/min
Time and temperature controls have been fitted in compliance with Part L of the Building Regulations? Yes
Type of control system (if applicable) Y Plan S Plan Other
Is the cylinder solar (or other renewable) compatible? Yes No
What is the hot water temperature at the nearest outlet? _____ °C
All appropriate pipes have been insulated up to 1 metre or the point where they become concealed Yes

UNVENTED SYSTEMS ONLY

Where is the pressure reducing valve situated (if fitted)? _____
What is the pressure reducing valve setting? _____ bar
Has a combined temperature and pressure relief valve and expansion valve been fitted and discharge tested? Yes No
The tundish and discharge pipework have been connected and terminated to Part G of the Building Regulations Yes
Are all energy sources fitted with a cut out device? Yes No
Has the expansion vessel or internal air space been checked? Yes No

THERMAL STORES ONLY

What store temperature is achievable? _____ °C
What is the maximum hot water temperature? _____ °C

ALL INSTALLATIONS

The hot water system complies with the appropriate Building Regulations Yes
The system has been installed and commissioned in accordance with the manufacturer's instructions Yes
The system controls have been demonstrated to and understood by the customer Yes
The manufacturer's literature, including Benchmark Checklist and Service Record, has been explained and left with the customer Yes

Commissioning Engineer's Signature _____
Customer's Signature _____
(To confirm satisfactory demonstration and receipt of manufacturer's literature)

*All installations in England and Wales must be notified to Local Authority Building Control (LABC) either directly or through a Competent Persons Scheme. A Building Regulations Compliance Certificate will then be issued to the customer.

Competent Persons Scheme.

SERVICE RECORD

It is recommended that your hot water system is serviced regularly and that the appropriate Service Record is completed.

Service Provider

Before completing the appropriate Service Record below, please ensure you have carried out the service as described in the manufacturer's instructions.

SERVICE 1 Date

Engineer Name _____

Company Name _____

Telephone Number _____

Comments _____

Signature _____

SERVICE 2 Date

Engineer Name _____

Company Name _____

Telephone Number _____

Comments _____

Signature _____

SERVICE 3 Date

Engineer Name _____

Company Name _____

Telephone Number _____

Comments _____

Signature _____

SERVICE 4 Date

Engineer Name _____

Company Name _____

Telephone Number _____

Comments _____

Signature _____

SERVICE 5 Date

Engineer Name _____

Company Name _____

Telephone Number _____

Comments _____

Signature _____

SERVICE 6 Date

Engineer Name _____

Company Name _____

Telephone Number _____

Comments _____

Signature _____

SERVICE 7 Date

Engineer Name _____

Company Name _____

Telephone Number _____

Comments _____

Signature _____

SERVICE 8 Date

Engineer Name _____

Company Name _____

Telephone Number _____

Comments _____

Signature _____

SERVICE 9 Date

Engineer Name _____

Company Name _____

Telephone Number _____

Comments _____

Signature _____

SERVICE 10 Date

Engineer Name _____

Company Name _____

Telephone Number _____

Comments _____

Signature _____

NIBE

NIBE Energy Systems Ltd
3C Broom Business Park
Bridge Way
Chesterfield S41 9QG
Phone 0845 095 1200
Fax 0845 095 1201
info@nibe.co.uk
www.nibe.co.uk

