

---

## Spare parts catalogue

2/2019 edition

Valid from 11/2019

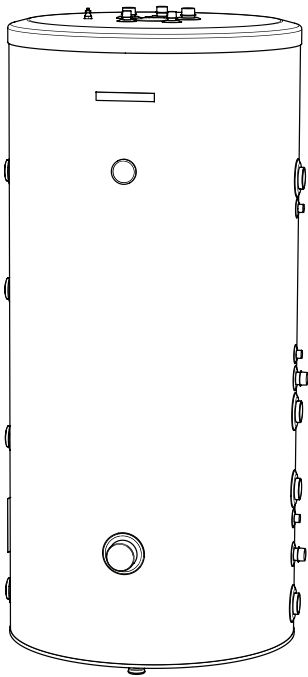

# KEY:

Type of device



**BA-ST 9030-1FEDC**



BA-ST 9030-1FEDC

No.	Index	Description
1	26198	Top cover Mega 300N
2	26196	Top insulation BU-300.8N
3	22612	Isolated magnesium anode 26x1100
...		
14		Flange insulation $\phi$ 120 with hole
15	27988	Flange cover $\phi$ 250 with hole $\phi$ 73

Component order code

Component description

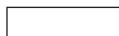
Construction design number

-  Available spare parts
-  Spare parts available on request

# List of contents

MELITE	4
BA-ST 9022-FE 9030-FE 9040-FE 9050-FE 9075-FE 9100-FE	6
BA-ST 9010-1FE 9012-FE 9015-1FE	8
BA-ST 9022-1FE 9030-1FE 9040-1FE 9050-1FE 9075-1FE 9100-1FE	10
BA-ST 9022-2FE 9030-2FE 9040-2FE 9050-2FE 9075-2FE 9100-2FE	12
BA-ST 9030-1FEDC 9040-1FEDC 9050-1FEDC	14
UKV 20-220 20-300 20-500 20-750 20-1000	16
UKVS 20-300 20-500 20-750 20-1000	18
BA-WH 8040/15-F 8050/20-F 8075/30-F 8100/30 -F	20
BA-WH 8040/15-1F 8050/20-1F 8075/30-1F 8100/30-1F	22
BA-WH 8040/15-2F 8050/20-2F 8075/30-2F 8100/30-2F	24
BA-WH 8050/30-F 8050/30-1F	26
ELK 9	28

# MELITE

BOTTOM VIEW

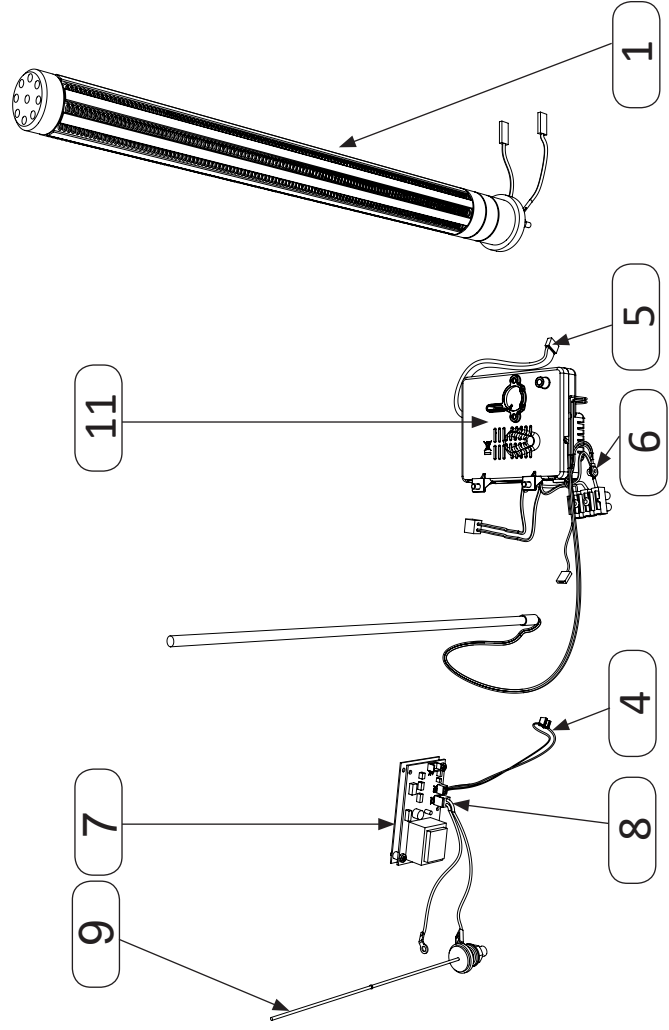
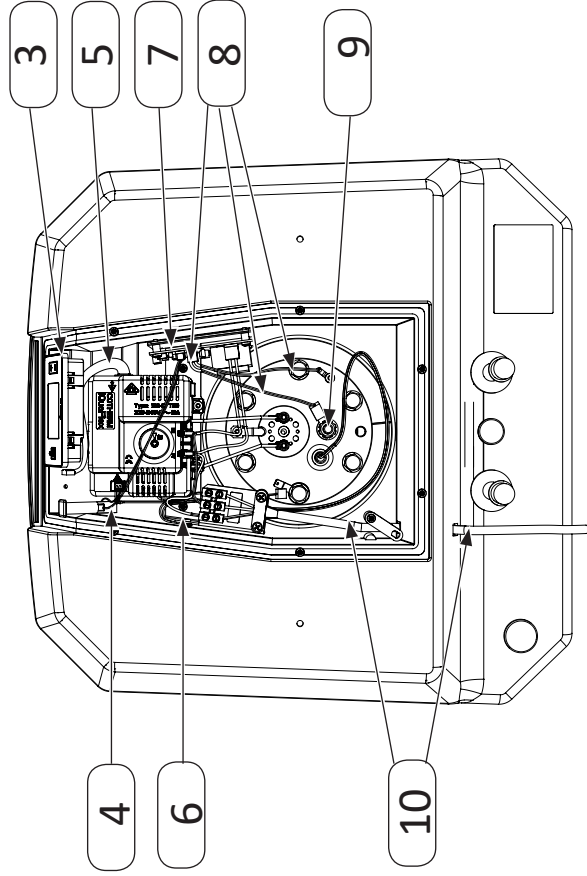
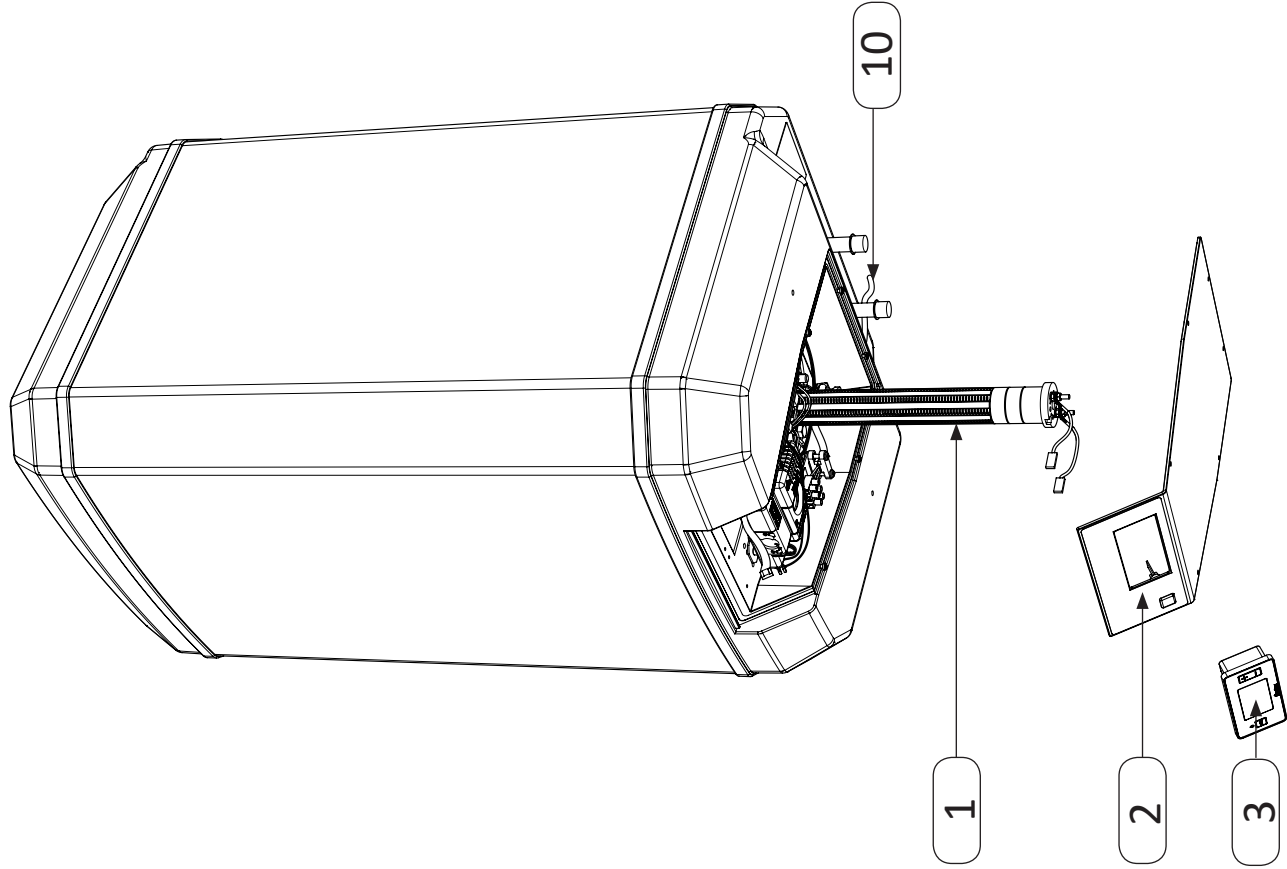

# MELITE

MELITE 60		MELITE 80		MELITE 100		MELITE 120	
No.	Index	Description	Index	Description	Index	Description	Description
1	718740	Ceramic heater 1,5kW/230V	718472	Ceramic heater 2,0kW/230V	718472	Ceramic heater 2,0kW/230V	Ceramic heater 2,0kW/230V
2	407480	Bottom cover Melite complete	407480	Bottom cover Melite complete	407480	Bottom cover Melite complete	Bottom cover Melite complete
3	718474	IFG220 display - white	718474	IFG220 display - white	718474	IFG220 display - white	IFG220 display - white
4	718866	Signal lamp cable	718866	Signal lamp cable	718866	Signal lamp cable	Signal lamp cable
5	718865	Cable ICB00005 L=300	718865	Cable ICB00005 L=300	718865	Cable ICB00005 L=300	Cable ICB00005 L=300
6	718863	Cable Z180	718863	Cable Z180	718863	Cable Z180	Cable Z180
7	434863	Titanium anode control plate	434863	Titanium anode control plate	434863	Titanium anode control plate	Titanium anode control plate
8	524689	Titanium anode cable	524689	Titanium anode cable	524689	Titanium anode cable	Titanium anode cable
9	434864	F-1210 titanium anode	434864	F-1210 titanium anode	434864	F-1210 titanium anode	F-1210 titanium anode
10	718864	Complete power cable 3x1,5	718864	Complete power cable 3x1,5	718864	Complete power cable 3x1,5	Complete power cable 3x1,5
11	718473	iBSC120 Thermoregulator	718473	iBSC120 Thermoregulator	718473	iBSC120 Thermoregulator	iBSC120 Thermoregulator

# BA-ST 9022-FE 9030-FE 9040-FE 9050-FE 9075-FE 9100-FE

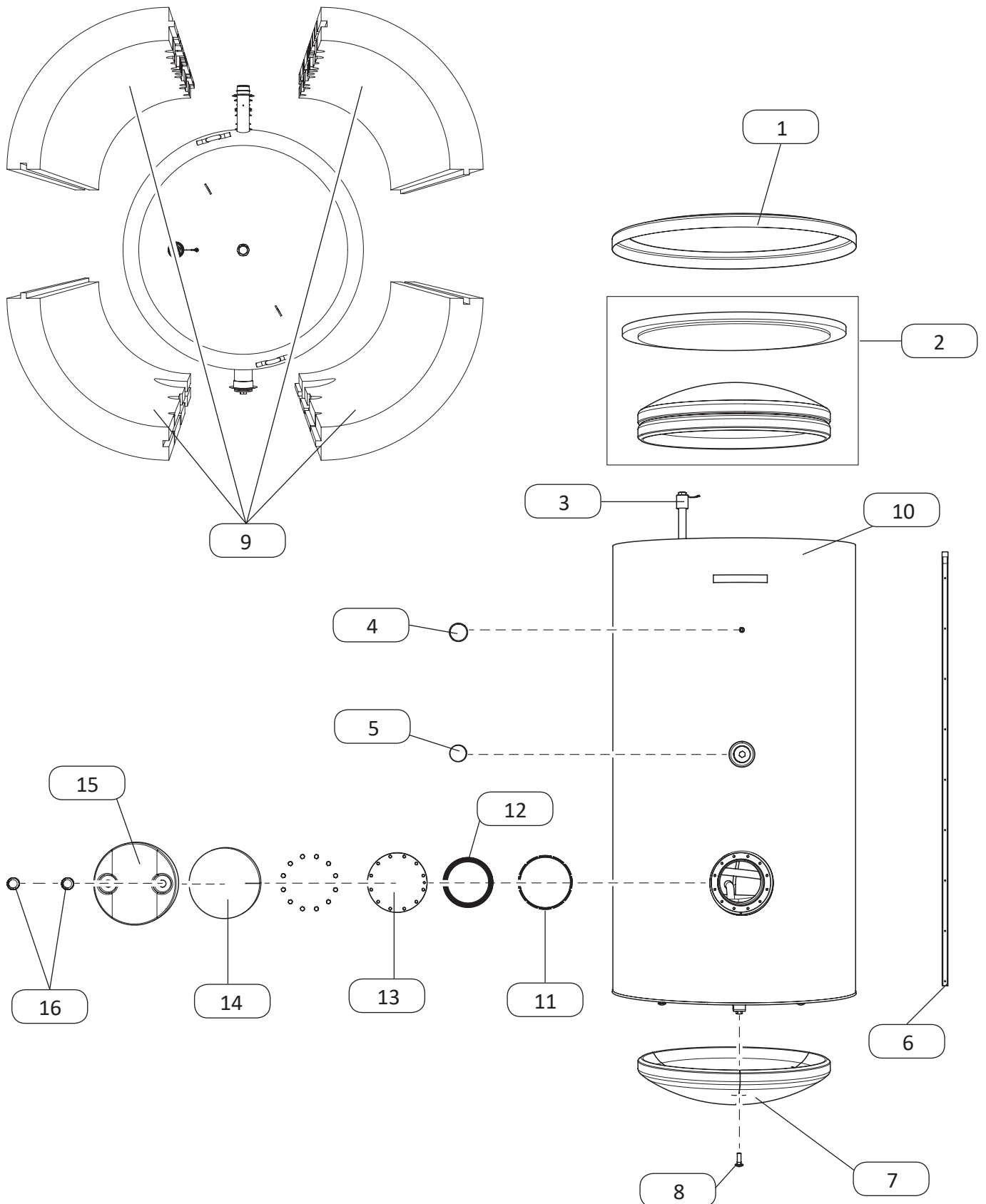



# BA-ST 9010-1FE 9012-FE 9015-1FE

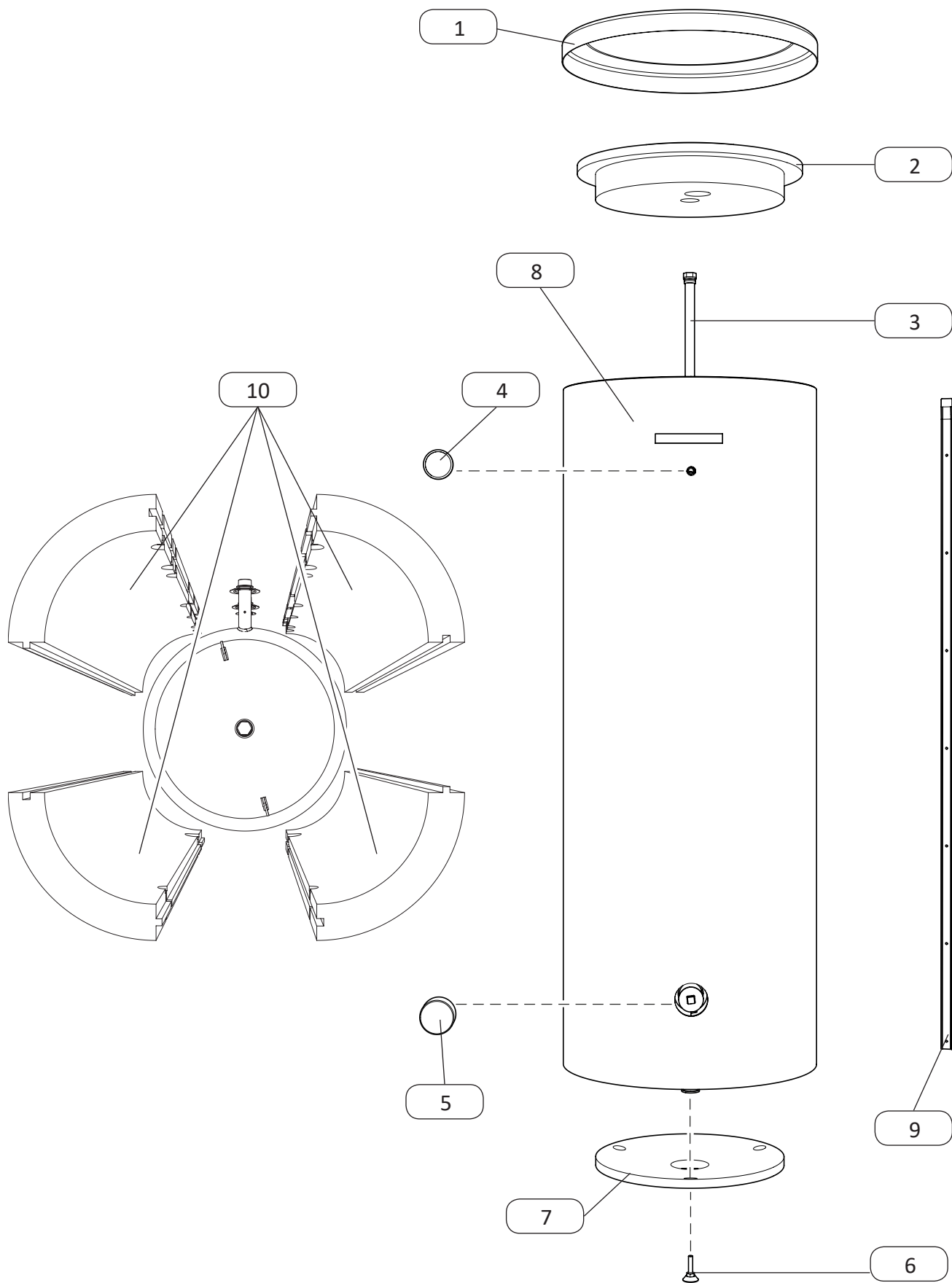



## BA-ST 9010-1FE 9012-1FE 9015-1FE

BA-ST 9010-1FE			BA-ST 9012-1FE			BA-ST 9015-1FE		
No.	Index	Description	Index	Description	Index	Description	Index	Description
1	23077	Top cover	23077	Top cover	23077	Top cover	23077	Top cover
2	23074	Top insulation 100-220.81	23074	Top insulation 100-220.81	23074	Top insulation 100-220.81	23074	Top insulation 100-220.81
3	20925	Magnesium anode 21,3x510	22170	Magnesium anode 21,3x590	21822	Magnesium anode 21,3x700	21822	Magnesium anode 21,3x700
4	22026	Thermometer 0-120°C	22026	Thermometer 0-120°C	22026	Thermometer 0-120°C	22026	Thermometer 0-120°C
5	23365	Plug ø70	23365	Plug ø70	23365	Plug ø70	23365	Plug ø70
6		Adjustable foot M10x50 ø35		Adjustable foot M10x50 ø35		Adjustable foot M10x50 ø35		Adjustable foot M10x50 ø35
7	23075	Bottom insulation 100-220.81	23075	Bottom insulation 100-220.81	23075	Bottom insulation 100-220.81	23075	Bottom insulation 100-220.81
8	23455	Outside shell cover W-E 100.81B	23222	Outside shell cover W-E 125.81B	23456	Outside shell cover W-E 150.81B	23456	Outside shell cover W-E 150.81B
9	23076	Metal strip M760x26,2x0,7	23224	Metal strip M925x26,2x0,7		Metal strip M1097x26,2x0,7		Metal strip M1097x26,2x0,7
10	23463	Insulation set W-E 100.81B	23223	Insulation set W-E 125.81B	23464	Insulation set W-E 150.81B	23464	Insulation set W-E 150.81B

# BA-ST 9022-1FE 9030-1FE 9040-1FE 9050-1FE 9075-1FE 9100-1FE

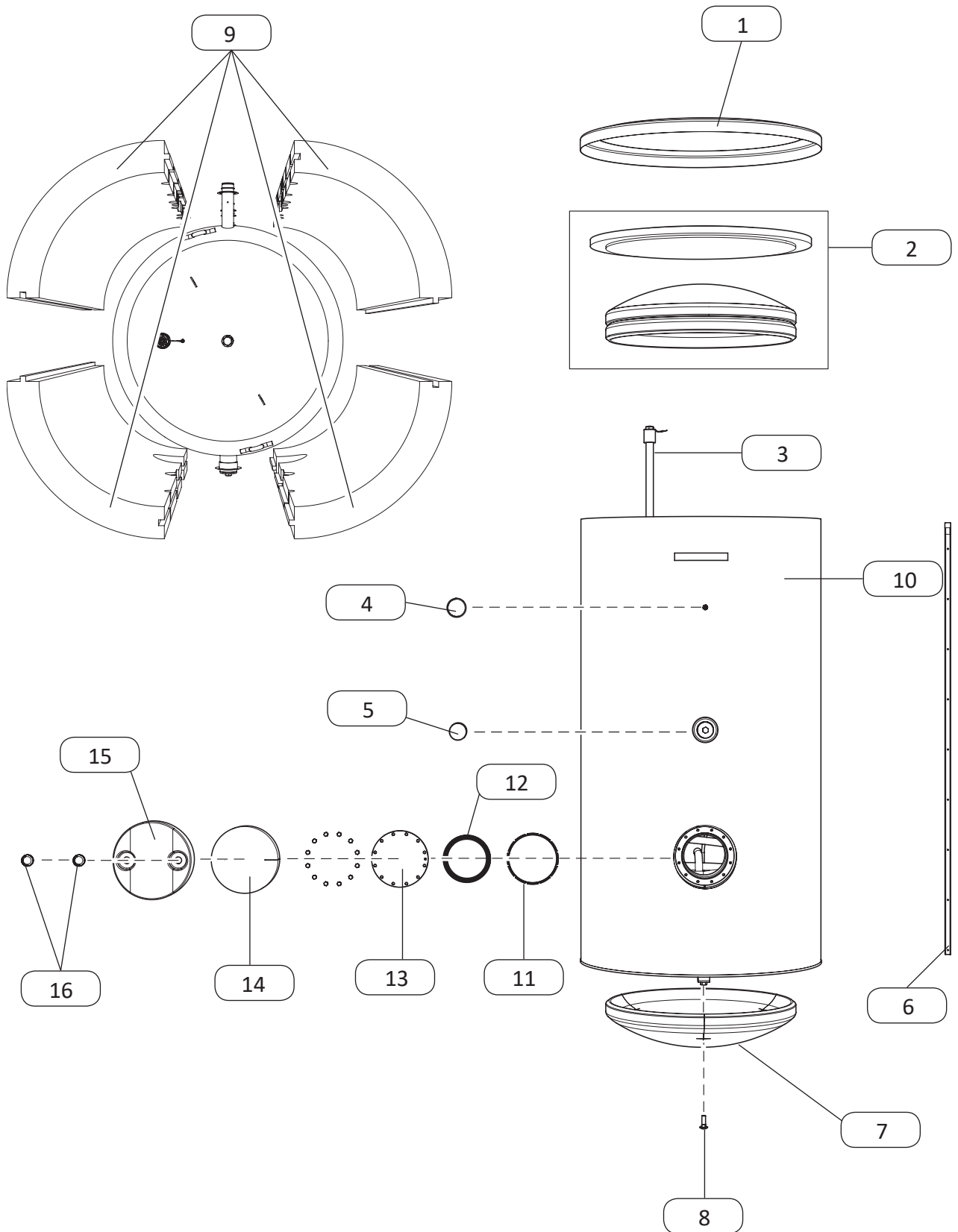



# BA-ST 9022-2FE 9030-2FE 9040-2FE 9050-2FE 9075-2FE 9100-2FE

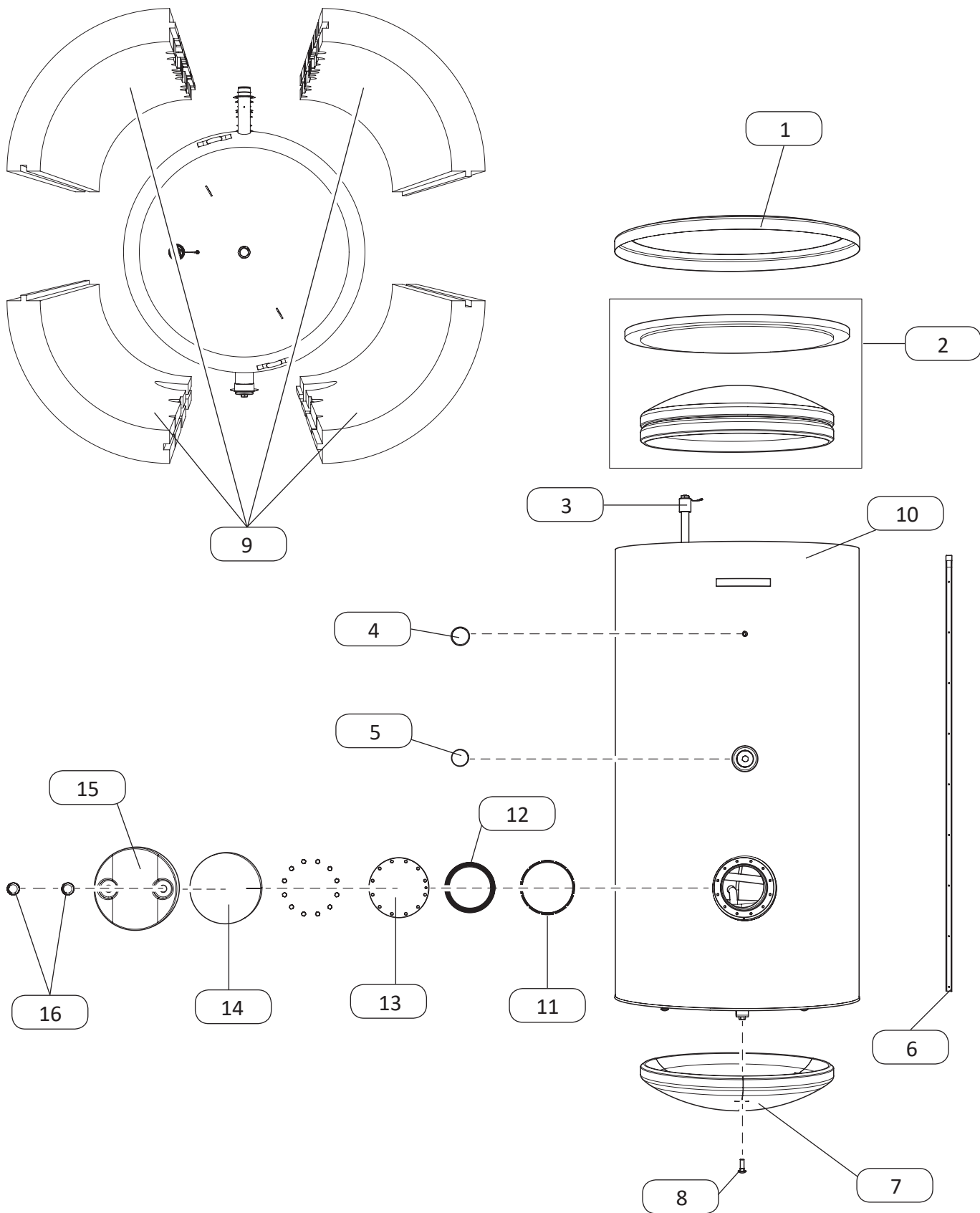



# BA-ST 9030-1FEDC 9040-1FEDC 9050-1FEDC

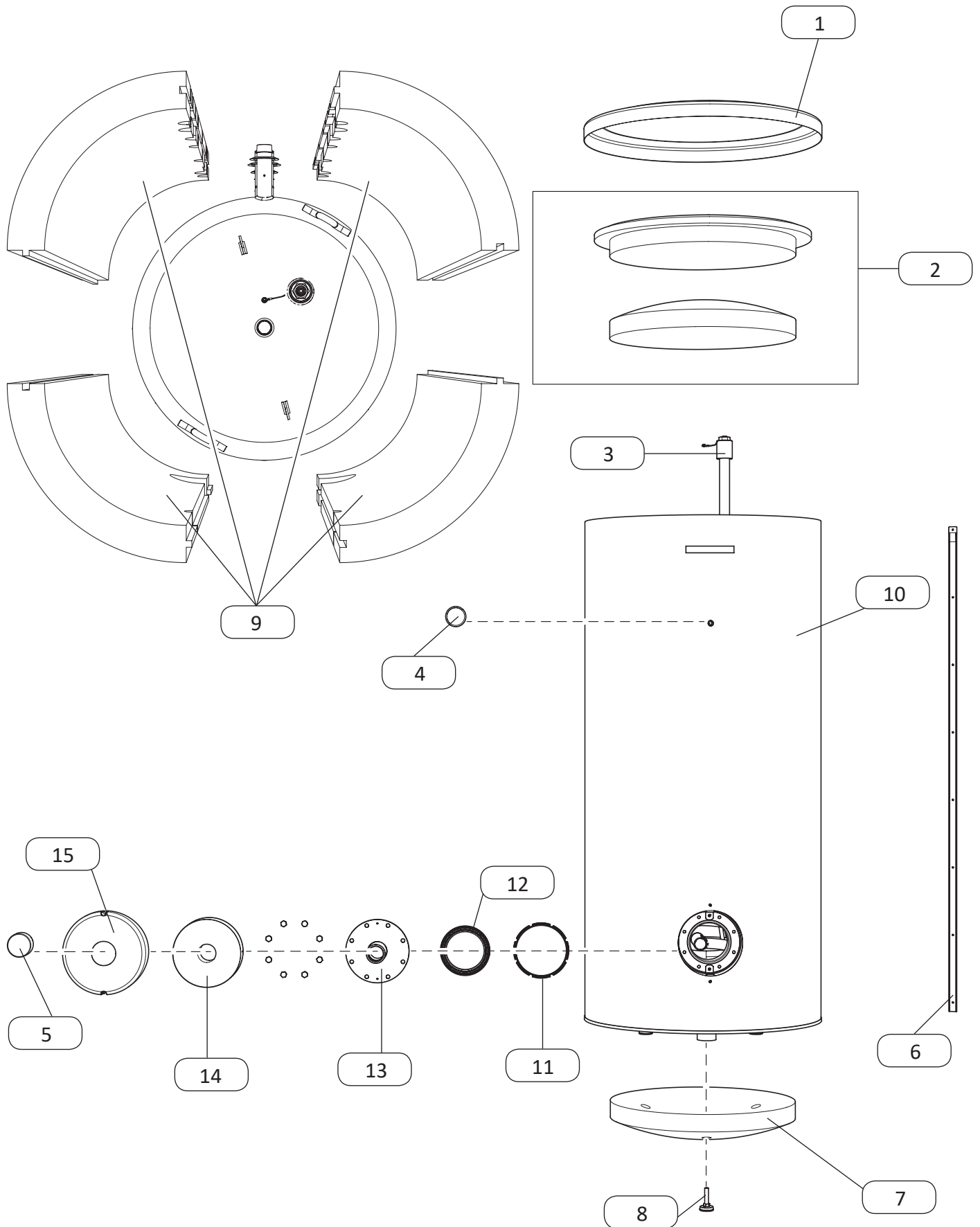

# BA-ST 9030-1FEDC 9040-1FEDC 9050-1FEDC

BA-ST 9030-1FEDC			BA-ST 9040-1FEDC			BA-ST 9050-1FEDC		
No.	Index	Description	Index	Description	Index	Description		
1	26198	Top cover Mega 300N	26660	Top cover Mega 400N	27844	Top cover Mega 500N		
2	26196	Top insulation BU-300.8N	26658	Top insulation Mega 400N	27843	Top insulation PSW-500B		
3	22612	Isolated magnesium anode 26x1100	22608	Isolated magnesium anode 33x1100	22608	Isolated magnesium anode 33x1100		
4	22026	Thermometer 0-120°C	22026	Thermometer 0-120°C	22026	Thermometer 0-120°C		
5	23365	Plug ø70	23365	Plug ø70	23365	Plug ø70		
6	26199	Metal strip M1560x26,2x0,7		Metal strip M1615x26,2x0,7	27845	Metal strip M1755x26,2x0,7		
7		Bottom insulation ø575x50		Bottom insulation ø656x50		Bottom insulation ø700x50		
8	16149	Adjustable foot M12x50 ø43	16149	Adjustable foot M12x50 ø43	16149	Adjustable foot M12x50 ø43		
9		Insulation set W-E 300.81 PC N	26659	Insulation set W-E 400.81 PC N		Insulation set W-E 500.81 PC N		
10	28485	Outside shell cover W-E 300.81 PC N	26657	Outside shell cover W-E 400.81 PC N		Outside shell cover W-E 500.81 PC N		
11	23459	Distance flange ø120	23459	Distance flange ø120	23459	Distance flange ø120		
12	033811	Flange gasket ø150	033811	Flange gasket ø150	033811	Flange gasket ø150		
13		Flange cover ø120 with socket l=80		Flange cover ø120 with socket l=95		Flange cover ø120 with socket l=95		
14		Flange insulation ø120 with hole		Flange insulation ø120 with hole		Flange insulation ø120 with hole		
15	27988	Flange cover ø250 with hole ø73	27988	Flange cover ø250 with hole ø73	27988	Flange cover ø250 with hole ø73		

# UKV 20-220 20-300 20-500 20-750 20-1000

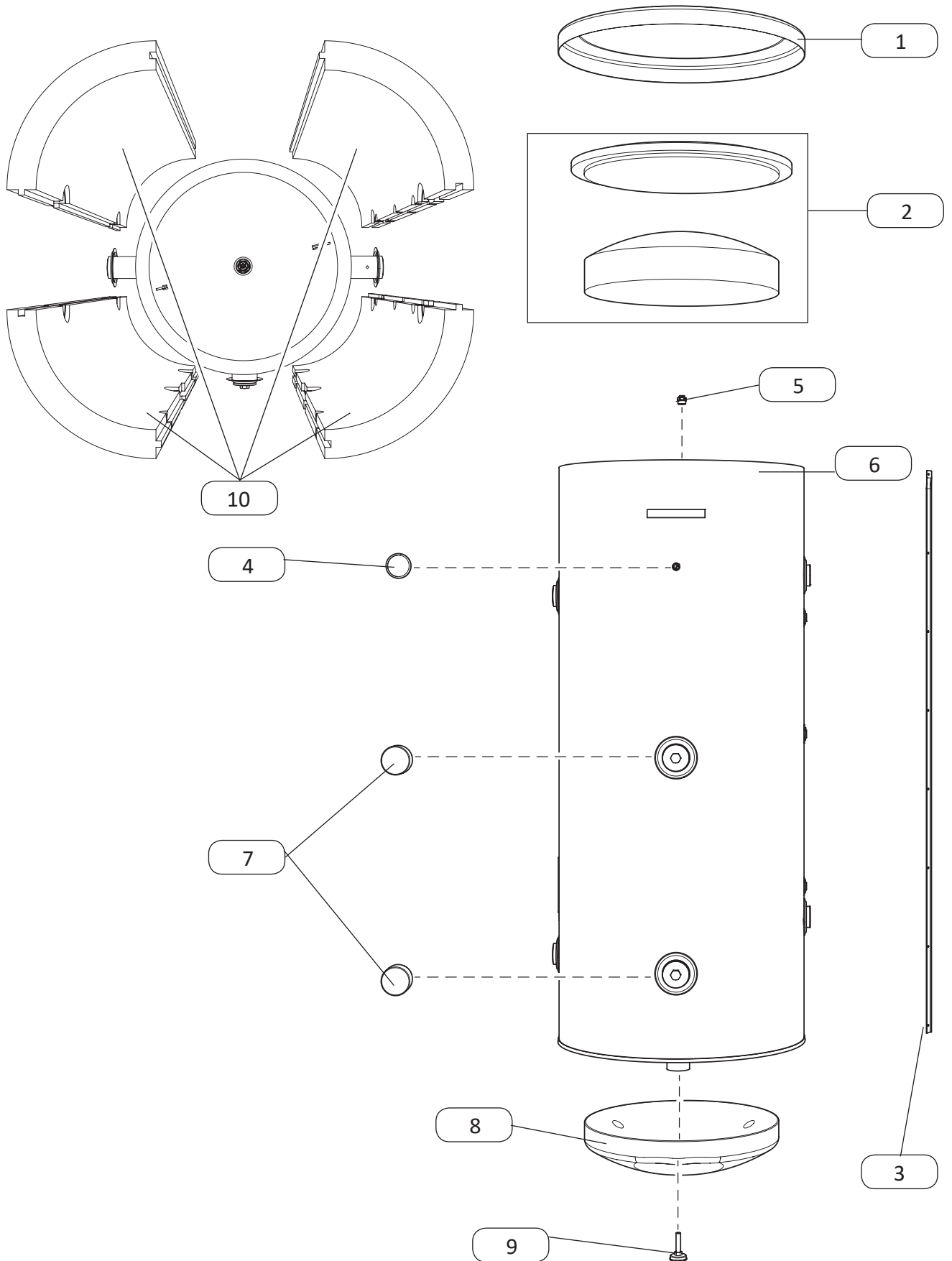



# UKV 20-220 20-300 20-500 20-750 20-1000

UKV 20-220			UKV 20-300			UKV 20-500			UKV 20-750			UKV 20-1000		
No.	Index	Description	Index	Description	Index	Description	Index	Description	Index	Description	Index	Description	Index	Description
1	28610	Top cover Mega 220N	26198	Top cover Mega 300N	27844	Top cover Mega 500N		Top cover Mega 750N	26667	Top cover Mega 1000N				
2		Top insulation	26196	Top insulation BU-300.8N	27843	Top insulation BU-500.8N		Top insulation	26666	Top insulation BU-1000.8N				
3	28607	Metal strip M1585x26,2x0,7	26199	Metal strip M1560x26,2x0,7	27845	Metal strip M1755x26,2x0,7		Metal strip M1930x26,2x0,7	26663	Metal strip M1980x26,2x0,7				
4	22026	Thermometer 0-120°C I=55	22026	Thermometer 0-120°C I=55	22026	Thermometer 0-120°C I=55		Thermometer 0-120°C I=90	22022	Thermometer 0-120°C I=90				
5		Vent ½" UKV		Vent ½" UKV		Vent ½" UKV		Vent ½" UKV		Vent ½" UKV				
6	26653	Outside shell cover BU-220.8N	26195	Outside shell cover BU-300.8N	28150	Outside shell cover BU-500.8N		Outside shell cover BU-750.8N	26664	Outside shell cover BU-1000.8N				
7	23365	Plug ø70	23365	Plug ø70	23365	Plug ø70		Plug ø70	23365	Plug ø70				
8		Bottom insulation ø470x50		Bottom insulation ø575x50		Bottom insulation ø700x50		Bottom insulation ø800x50		Bottom insulation ø910x50				
9	16149	Adjustable foot M12x50 ø43	16149	Adjustable foot M12x50 ø43	16149	Adjustable foot M12x50 ø43		Carriage screw M16x50-8-8	016747	Carriage screw M16x50-8-8				
10		Insulation set BU-220.8N	26197	Insulation set BU-300.8N		Insulation set BU-500.8N		Insulation set BU-750.8N		Insulation set BU-1000.8N				

# UKVS 20-300 20-500 20-750 20-1000

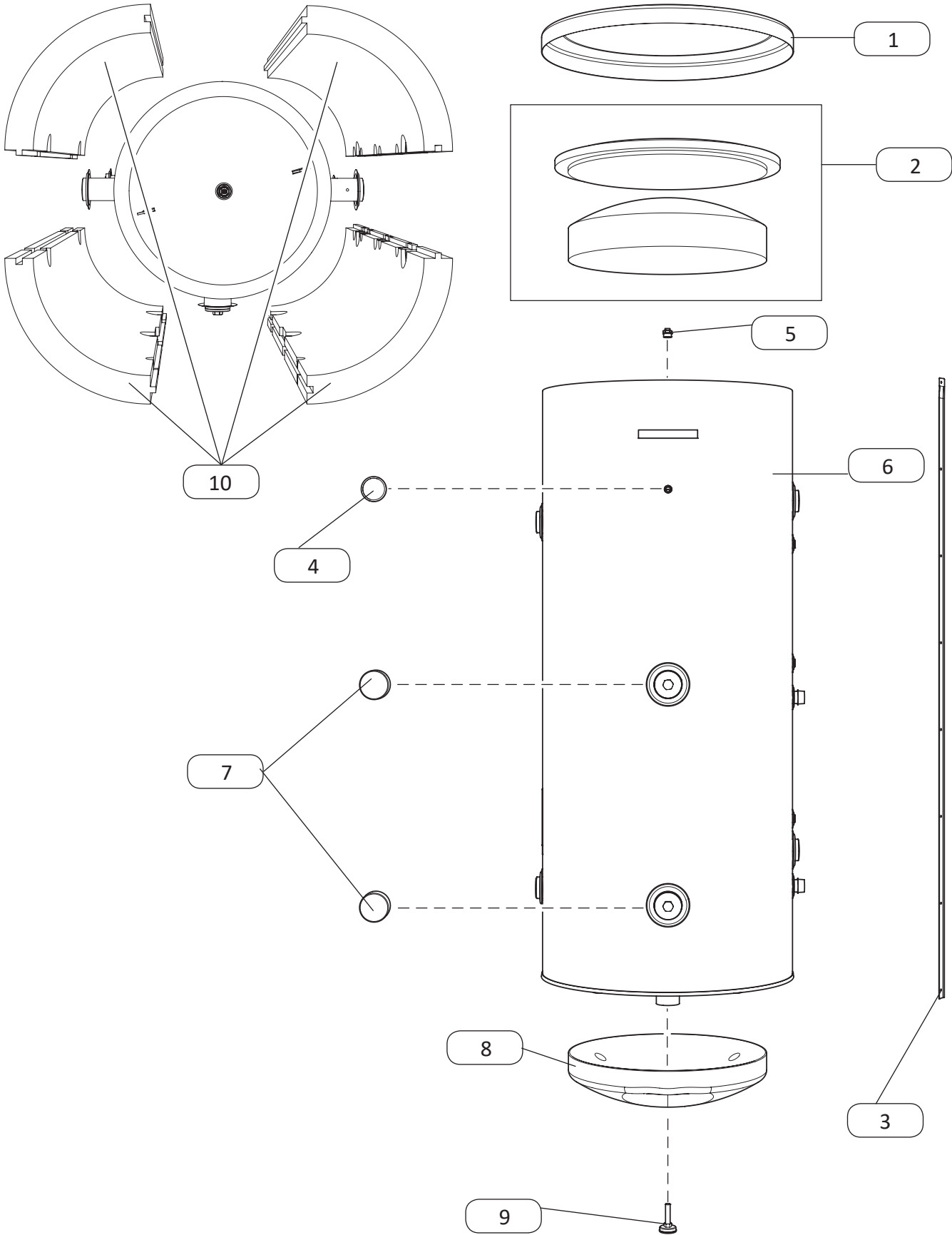

# UKVS 20-300 20-500 20-750 20-1000

UKVS 20-300			UKVS 20-500			UKVS 20-750			UKVS 20-1000		
No.	Index	Description	Index	Description	Index	Description	Index	Description	Index	Description	
1	26198	Top cover Mega 300N	27844	Top cover Mega 500N		Top cover Mega 750N	26667	Top cover Mega 1000N			
2	26196	Top insulation BU-300.8N	27843	Top insulation BU-500.8N		Top insulation	26666	Top insulation BU-1000.8N			
3	26199	Metal strip M1560x26,2x0,7	27845	Metal strip M1755x26,2x0,7		Metal strip M1930x26,2x0,7	26663	Metal strip M1980x26,2x0,7			
4	22026	Thermometer 0-120°C l=55	22026	Thermometer 0-120°C l=55	22022	Thermometer 0-120°C l=90	22022	Thermometer 0-120°C l=90			
5		Vent ½'' UKV		Vent ½'' UKV		Vent ½'' UKV		Vent ½'' UKV			
6		Outside shell cover BUW-300.8N	28150	Outside shell cover BUW-500.8N		Outside shell cover BUW-750.8N		Outside shell cover BUW-1000.8N			
7	23365	Plug ø70	23365	Plug ø70	23365	Plug ø70	23365	Plug ø70			
8		Bottom insulation ø575x50		Bottom insulation ø700x50		Bottom insulation ø800x50		Bottom insulation ø910x50			
9	16149	Adjustable foot M12x50 ø43	16149	Adjustable foot M12x50 ø43	016747	Carriage screw M16x50-8.8	016747	Carriage screw M16x50-8.8			
10		Insulation set BUW-300.8N	28151	Insulation set BUW-500.8N		Insulation set BUW-750.8N		Insulation set BUW-1000.8N			

# BA-WH 8040/15-F 8050/20-F 8075/30-F 8100/30-F

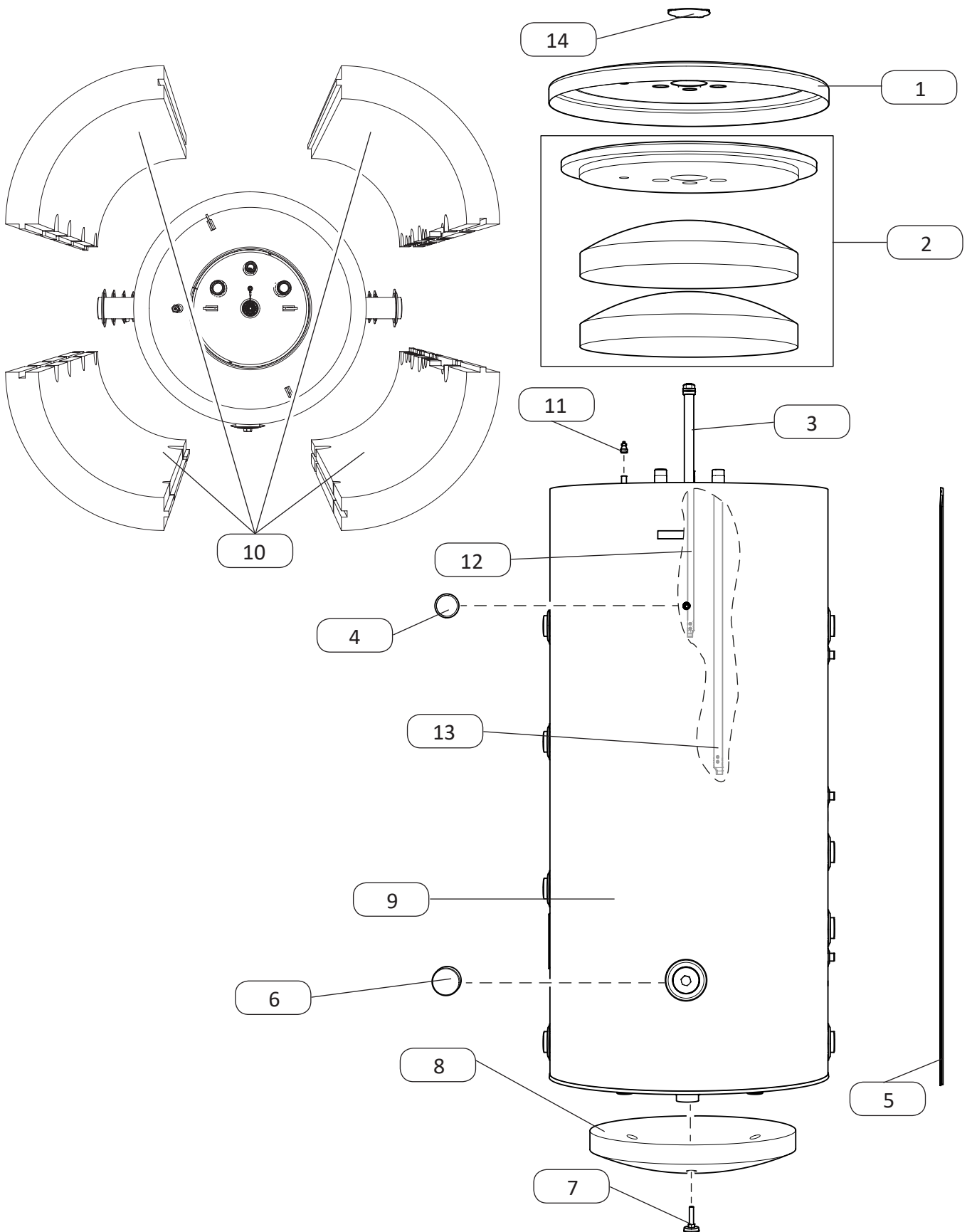

# BA-WH 8040/15-F 8050/20-F 8075/30-F 8100/30-F

BA-WH 8040/15-F			BA-WH 8050/20-F			BA-WH 8075/30-F			BA-WH 8100/30-F		
No.	Index	Description	Index	Description	Index	Description	Index	Description	Index	Description	
1		Top cover 400.92N	28538	Top cover 500.92 N		Top cover 750.91N/92N		Top cover 1000.91/92N			
2		Top insulation BUZ-400/150.91N		Top insulation BUZ-500/200.92N		Top insulation BUZ-750/300.91N		Top insulation BUZ-1000/300.91N			
3	20924	Isolated magnesium anode 26x350	20924	Isolated magnesium anode 26x350	20925	Isolated magnesium anode 26x650	20925	Isolated magnesium anode 26x650	20925		
4	22026	Thermometer 0-120°C	22026	Thermometer 0-120°C	22022	Thermometer 0-120°C	22022	Thermometer 0-120°C	22022		
5		Metal strip M1615x26,2x0,7	27845	Metal strip M1755x26,2x0,7		Metal strip M1930x26,2x0,7		Metal strip M1980x26,2x0,7	26663		
6	23365	Plug ø70	23365	Plug ø70	23365	Plug ø70	23365	Plug ø70	23365		
7	16149	Adjustable foot M12x50 ø43	16149	Adjustable foot M12x50 ø43	016747	Carriage screw M16x50-8.8	016747	Carriage screw M16x50-8.8	016747		
8		Bottom insulation ø656x50		Bottom insulation ø700x50		Bottom insulation ø800x50		Bottom insulation ø910x50			
9		Outside shell cover BUZ-400/150.91/92N		Outside shell cover BUZ-500/200.91N/92N	26079	Outside shell cover BUZ-750/300.91N/92N		Outside shell cover BUZ-1000/300.91N/92N			
10		Insulation set BUZ-400/150.91N		Insulation set BUZ-500/200.91/92N		Insulation set BUZ-750/300.91N/92N		Insulation set BUZ-1000/300.91/92N			
11	27987	Vent ¼"	27987	Vent ¼"	27987	Vent ¼"	27987	Vent ¼"	27987		
12		PEX tube ø18/14 l=493		PEX tube ø18/14 l=493		PEX tube ø18/14 l=493		PEX tube ø18/14 l=493			
13		PEX tube ø25/20 l=890		PEX tube ø25/20 l=890		PEX tube ø25/20 l=1253		PEX tube ø25/20 l=1253			
14	20926	Plug top cover BUZ	20926	Plug top cover BUZ	20926	Plug top cover BUZ	20926	Plug top cover BUZ	20926		

# BA-WH 8040/15-1F 8050/20-1F 8075/30-1F 8100/30-1F

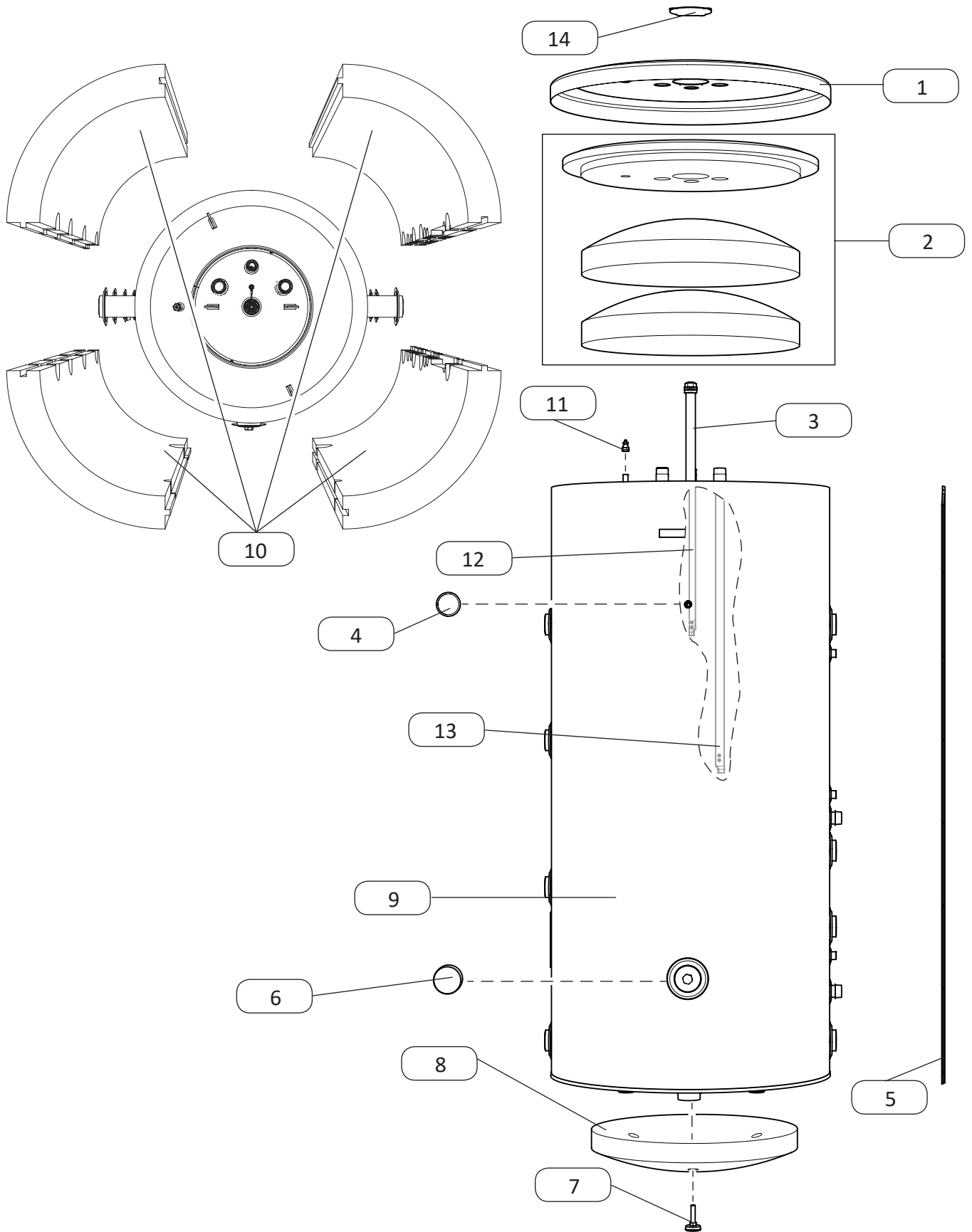

# BA-WH 8040/15-1F 8050/20-1F 8075/30-1F 8100/30-1F

BA-WH 8040/15-1F			BA-WH 8050/20-1F			BA-WH 8075/30-1F			BA-WH 8100/30-1F		
No.	Index	Description	Index	Description	Index	Description	Index	Description	Index	Description	
1		Top cover 400.92N	28538	Top cover 500.92 N		Top cover 750.91N/92N		Top cover 1000.91/92N			
2		Top insulation BUZ-400/150.91N		Top insulation BUZ-500/200.92N		Top insulation BUZ-750/300.91N		Top insulation BUZ-1000/300.91N			
3	20924	Isolated magnesium anode 26x350	20924	Isolated magnesium anode 26x350	20925	Isolated magnesium anode 26x650	20925	Isolated magnesium anode 26x650	20925		
4	22026	Thermometer 0-120°C	22026	Thermometer 0-120°C	22022	Thermometer 0-120 °C	22022	Thermometer 0-120°C	22022		
5		Metal strip M1615x26,2x0,7	27845	Metal strip M1755x26,2x0,7		Metal strip M1930x26,2x0,7		Metal strip M1980x26,2x0,7	26663		
6	23365	Plug ø70	23365	Plug ø70	23365	Plug ø70	23365	Plug ø70	23365		
7	16149	Adjustable foot M12x50 ø43	16149	Adjustable foot M12x50 ø43	016747	Carriage screw M16x50-8.8	016747	Carriage screw M16x50-8.8	016747		
8		Bottom insulation ø656x50		Bottom insulation ø700x50		Bottom insulation ø800x50		Bottom insulation ø910x50			
9		Outside shell cover BUZ-400/150.91/92N		Outside shell cover BUZ-500/200.91N/92N	26079	Outside shell cover BUZ-750/300.91N/92N		Outside shell cover BUZ-1000/300.91N/92N			
10		Insulation set BUZ-400/150.91N		Insulation set BUZ-500/200.91/92N		Insulation set BUZ-750/300.91N/92N		Insulation set BUZ-1000/300.91/92N			
11	27987	Vent ¼"	27987	Vent ¼"	27987	Vent ¼"	27987	Vent ¼"	27987		
12		PEX tube ø18/14 l=493		PEX tube ø18/14 l=493		PEX tube ø18/14 l=493		PEX tube ø18/14 l=493			
13		PEX tube ø25/20 l=890		PEX tube ø25/20 l=890		PEX tube ø25/20 l=1253		PEX tube ø25/20 l=1253			
14	20926	Plug top cover BUZ	20926	Plug top cover BUZ	20926	Plug top cover BUZ	20926	Plug top cover BUZ	20926		

# BA-WH 8040/15-2F 8050/20-2F 8075/30-2F 8100/30-2F

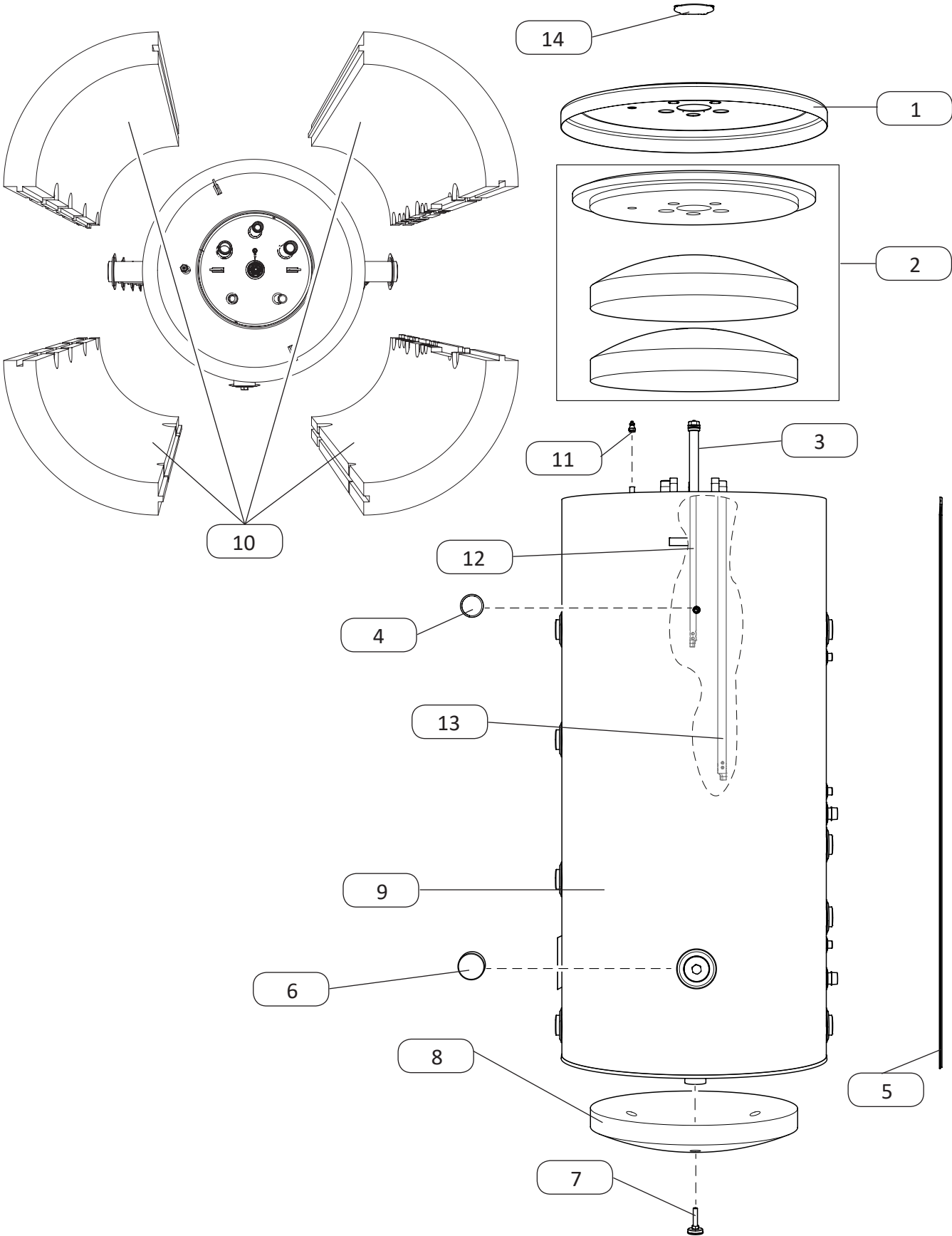



# BA-WH 8040/15-2F 8050/20-2F 8075/30-2F 8100/30-2F

BA-WH 8040/15-2F		BA-WH 8050/20-2F		BA-WH 8075/30-2F		BA-WH 8100/30-2F		
No.	Index	Description	Index	Description	Index	Description	Index	Description
1		Top cover 400.92N	28538	Top cover 500.92 N		Top cover 750 91N/92N		Top cover 1000.91/92N
2		Top insulation BUZ-400/150.91N		Top insulation BUZ-500/200.92N		Top insulation BUZ-750/300.91N		Top insulation BUZ-1000/300.91N
3	20925	Isolated magnesium anode 26x650	20925	Isolated magnesium anode 26x650	22611	Isolated magnesium anode 26x950	22611	Isolated magnesium anode 26x950
4	22026	Thermometer 0-120°C	22026	Thermometer 0-120°C	22022	Thermometer 0-120°C	22022	Thermometer 0-120°C
5		Metal strip M1615x26,2x0,7	27845	Metal strip M1755x26,2x0,7		Metal strip M1930x26,2x0,7	26663	Metal strip M1980x26,2x0,7
6	23365	Plug ø70	23365	Plug ø70	23365	Plug ø70	23365	Plug ø70
7	16149	Adjustable foot M12x50 ø43	16149	Adjustable foot M12x50 ø43	016747	Carriage screw M16x50-8.8	016747	Carriage screw M16x50-8.8
8		Bottom insulation ø656x50		Bottom insulation ø700x50		Bottom insulation ø800x50		Bottom insulation ø910x50
9		Outside shell cover BUZ-400/150.91/92N		Outside shell cover BUZ-500/200.91N/92N	26079	Outside shell cover BUZ-750/300.91N/92N		Outside shell cover BUZ-1000/300.91N/92N
10		Insulation set BUZ-400/150.91N		Insulation set BUZ-500/200.91/92N		Insulation set BUZ-750/300.91N/92N		Insulation set BUZ-1000/300.91/92N
11	27987	Vent ¼"	27987	Vent ¼"	27987	Vent ¼"	27987	Vent ¼"
12		PEX tube ø18/14 l=493		PEX tube ø18/14 l=493		PEX tube ø18/14 l=493		PEX tube ø18/14 l=493
13		PEX tube ø25/20 l=890		PEX tube ø25/20 l=890		PEX tube ø25/20 l=1253		PEX tube ø25/20 l=1253
14	20926	Plug top cover BUZ	20926	Plug top cover BUZ	20926	Plug top cover BUZ	20926	Plug top cover BUZ

# BA-WH 8050/30-F

## 8050/30-1F

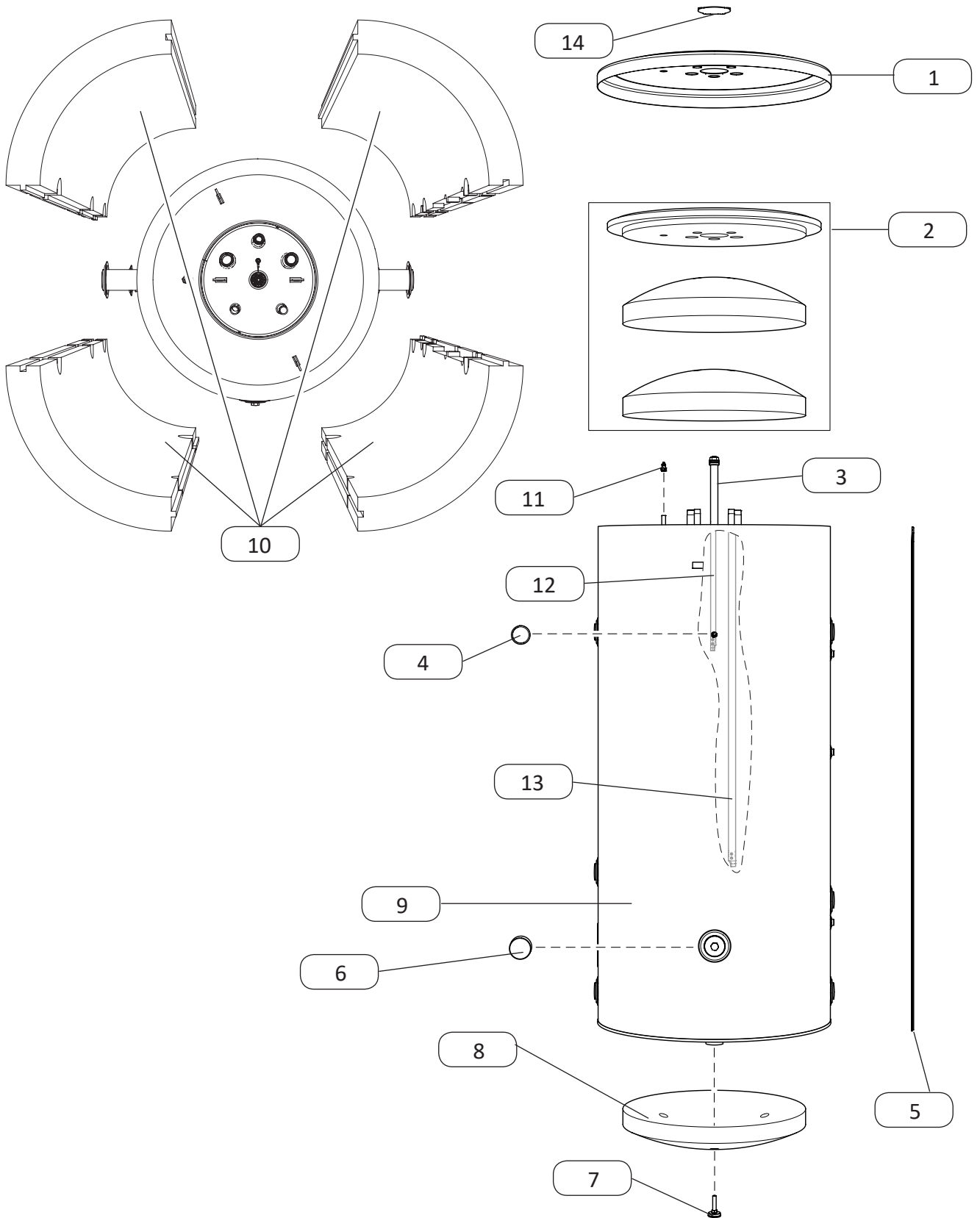

# BA-WH 8050/30-F 8050/30-1F

BA-WH 8050/30-F

BA-WH 8050/30-1F

Nr	Index	Description	Index	Description
1	28538	Top cover 500.92 N	28538	Top cover 500.92 N
2		Top insulation		Top insulation
3	20925	Isolated magnesium anode 26x650	22611	Isolated magnesium anode 26x950
4	22026	Thermometer 0-120°C	22026	Thermometer 0-120°C
5	27845	Metal strip M175x26,2x0,7	27845	Metal strip M175x26,2x0,7
6	23365	Plug ø70	23365	Plug ø70
7	16149	Adjustable foot M12x50 ø43	16149	Adjustable foot M12x50 ø43
8		Bottom insulation ø700x50		Bottom insulation ø700x50
9	27405	Outside shell cover BUZ-500/300.90N/93N	27405	Outside shell cover BUZ-500/300.90N/93N
10		Insulation set BUZ-500/300.90N		Insulation set BUZ-500/300.93N
11	27987	Vent ¼"	27987	Vent ¼"
12		PEX tube ø18/14 l=493		PEX tube ø18/14 l=493
13		PEX tube ø25/20 l=1253		PEX tube ø25/20 l=1253
14	20926	Plug top cover BUZ	20926	Plug top cover BUZ

# ELK 9

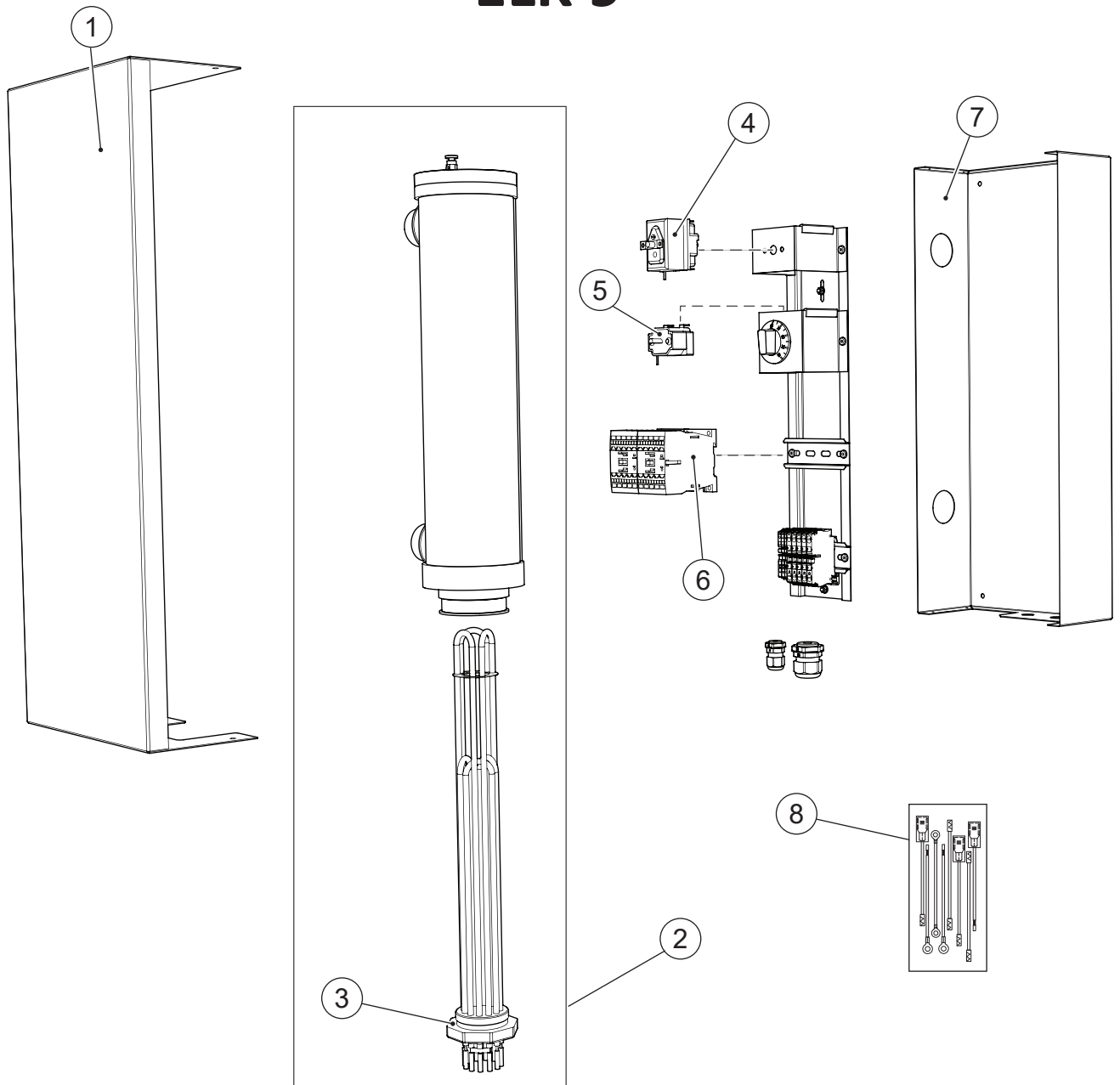

ELK 9		
No.	Index	Description
1		Front housing ELK9
2		ELK9 heater set
3	29343	Immersion heater 9 kW 230/400V
4	018460	Temperature limiter
5	21847	Thermostat 6-77+/-3 °C
6		Contacteur DILMC 9-10
7		Housing back ELK9
8		Wires set ELK9







