

Operating manual

NIBE

Ground source heat pump **NIBE F1355**



OHB EN 2436-2
731124

Quick guide

Navigation

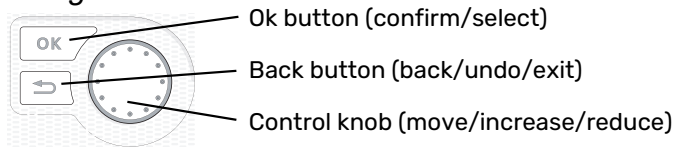

A detailed explanation of the button functions can be found on page 9.

How to scroll through menus and make different settings is described on page 11.

Set the indoor climate

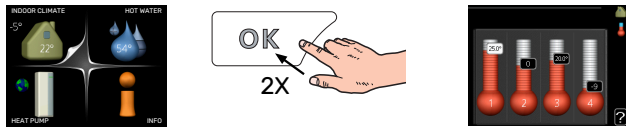

The mode for setting the indoor temperature is accessed by pressing the OK button twice, when in the start mode in the main menu. Read more about the settings on page 13.

Increase hot water volume



To increase the amount of hot water temporarily (if a water heater is installed for your F1355), first turn the control knob to select menu 2 (water droplet) and then press the OK button twice. Read more about the settings on page temporary lux.

Table of Contents

1	Important information	4
	Installation data	4
	Safety information	5
	Symbols	5
	Safety precautions	6
	Serial number	7
	Recovery	7
	Environmental information	7
2	myUplink	8
	Specification	8
	Connection	8
	Range of services	8
	myUplink PRO	8
3	Control - Introduction	9
	Display unit	9
	Menu system	9
4	Control - Menus	13
	Menu 1 - INDOOR CLIMATE	13
	Menu 2 - HOT WATER	21
	Menu 3 - INFO	24
	Menu 4 - HEAT PUMP	26
	Menu 5 - SERVICE	35
5	Service	47
	Service actions	47
6	Disturbances in comfort	54
	Info-menu	54
	Manage alarm	54
	Troubleshooting	54
	Alarm list	57
	Item register	66
	Contact information	67

Important information

Installation data

Product	F1355
Serial number Master	
Serial number, Slave 1	
Serial number, Slave 2	
Serial number, Slave 3	
Serial number, Slave 4	
Serial number, Slave 5	
Serial number, Slave 6	
Serial number, Slave 7	
Serial number, Slave 8	
Installation date	
Installer	
Type of brine - Mixing ratio/freezing point	
Active drilling depth/collector length	

No.	Name	Fact. sett.	Set
1.9.1.1	heating curve (offset)	0	
1.9.1.1	heating curve (curve slope)	7	

✓	Accessories

Serial number must always be given.

Certification that the installation is carried out according to instructions in the accompanying installer manual and applicable regulations.

Date _____

Signed _____

Safety information

The manual must be left with the customer.

For the latest version of the product's documentation, see nibe.eu.

This appliance is designed for use in a home environment and not intended to be used by persons (including children) with reduced physical, sensory or mental capabilities, or lack of experience and knowledge, unless they have been given supervision or instruction concerning use of the appliance by a person responsible for their safety. This in accordance to applicable parts of the low-voltage directive 2006/95/EC, LVD. The appliance is also intended for use by experts or trained users in shops, hotels, light industry, on farms and in similar environments. This in accordance to applicable parts of the machinery directive 2006/42/EC.

Children should be supervised to ensure that they do not play with the appliance.

This is an original instruction manual. Translation is not allowed without approval from NIBE.

Rights to make any design or technical modifications are reserved.

©NIBE 2024.

Do not start F1355 if there is a risk that the water in the system has frozen.

Water may drip from the safety valve's overflow pipe. The overflow pipe must be routed to a suitable drain, to prevent hot water splashes from causing harm. The overflow pipe must be inclined along its entire length to prevent pockets where water can accumulate, and must be frost-proof. The overflow pipe must be at least the same size as the safety valve. The overflow pipe must be visible and its mouth must be open and not placed close to electrical components.

The safety valves must be actuated regularly to remove dirt and to check that they are not blocked.

F1355 must be installed via an isolator switch. The cable area has to be dimensioned based on the fuse rating used.

Electrical installation and wiring must be carried out in accordance with national provisions.

If the supply cable is damaged, only NIBE, its service representative or similar authorised person may replace it to prevent any danger and damage.

Symbols

Explanation of symbols that may be present in this manual.



WARNING!

This symbol indicates serious danger to person or machine.



CAUTION!

This symbol indicates danger to person or machine.



NOTE!

This symbol indicates important information about what you should observe when maintaining your installation.



TIP!

This symbol indicates tips on how to facilitate using the product.

Safety precautions



WARNING!

The installation must be carried out by a qualified installer.

If you install the system yourself, serious problems may occur, for example water leaks, refrigerant leaks, electric shocks, fire and personal injury, as a result of a system malfunction.

Use original accessories and the stated components for the installation.

If parts other than those stated by us are used, water leaks, electric shocks, fire and personal injury may occur as the unit may not work properly.

Install the unit in a location with good support.

Unsuitable installation locations can cause the unit to fall and cause material damage and personal injury. Installation without sufficient support can also cause vibrations and noise.

Ensure that the unit is stable when installed, so that it can withstand earthquakes and strong winds.

Unsuitable installation locations can cause the unit to fall and cause material damage and personal injury.

The electrical installation must be carried out by a qualified electrician and the system must be connected as a separate circuit.

Power supply with insufficient capacity and incorrect function can cause electric shocks and fire.

Use types of pipe and tools stated for this type of refrigerant.

Using existing parts for other refrigerants can cause breakdowns and serious accidents due to process circuit bursts.

Do not perform any repairs yourself. Consult the dealer if the system requires repair.

Incorrectly performed repairs can cause water leakage, refrigerant leakage, electric shocks or fire.

Consult the dealer or an expert regarding removal of the heat pump.

Incorrect installation can cause water leakage, refrigerant leaks, electric shocks or fire.

Switch off the power supply in the event of a service or inspection.

If the power supply is not shut off, there is a risk of electric shocks and damage due to the rotating fan.

Do not run the unit with removed panels or protection.

Touching rotating equipment, hot surfaces or high voltage parts can cause personal injury due to entrapment, burns or electric shocks.

Cut the power before starting electrical work.

Failure to cut the power can cause electric shocks, damage and incorrect function of the equipment.

CARE

Do not use the unit for specialist purposes such as for storing food, cooling precision instruments, freeze-conservation of animals, plants or art.

This can damage the items.

Dispose of any packaging material correctly.

Any remaining packaging material can cause personal injury as it may contain nails and wood.

Do not touch any buttons with wet hands.

This can cause electric shocks.

Do not switch off the power supply immediately after the operation has stopped.

Wait for at least 5 minutes, otherwise there is a risk of water leakage or breakdown.

Do not control the system with the main switch.

This can cause fire or water leakage.

ESPECIALLY FOR UNITS INTENDED FOR R407C AND R410A

- Do not use other refrigerants than those intended for the unit.
- Do not use charging bottles. These types of bottles change the composition of the refrigerant, which makes the performance of the system worse.
- When filling refrigerant, the refrigerant must always leave the bottle in liquid form.
- R410A means that the pressure is about 1.6 times as high as for conventional refrigerants.
- The filling connections on units with R410A are different sizes, to prevent the system being filled with the incorrect refrigerant by mistake.

Serial number

The serial number can be found at the bottom right of the front cover, in the info menu (menu 3.1) and on the type plate (PZ1).

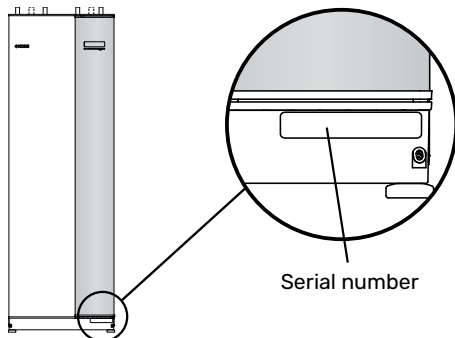

NOTE!

You need the product's (14 digit) serial number for servicing and support.

Recovery



Leave the disposal of the packaging to the installer who installed the product or to special waste stations.

Do not dispose of used products with normal household waste. It must be disposed of at a special waste station or dealer who provides this type of service.

Improper disposal of the product by the user results in administrative penalties in accordance with current legislation.

Environmental information

F-GAS REGULATION (EU) NO. 517/2014

This unit contains a fluorinated greenhouse gas that is covered by the Kyoto agreement.

The equipment contains R407C and R410A, fluorinated greenhouse gases with GWP values (Global Warming Potential) of 1774 and 2088 respectively. Do not release R407C or R410A into the atmosphere.

myUplink

With myUplink you can control the installation – where and when you want. In the event of any malfunction, you receive an alarm directly to your e-mail or a push notification to the myUplink app, which allows you to take prompt action.

Visit myuplink.com for more information.

Update your system to the latest software version.

Specification

You need the following in order for myUplink to be able to communicate with your F1355:

- network cable
- Internet connection
- account on myuplink.com

We recommend our mobile apps for myUplink.

Connection

To connect your system to myUplink:

1. Select connection type (wifi/Ethernet) in menu 4.1.3 – internet.
2. Mark “request new connection string” and press the OK button.
3. When a connection string has been produced, it is shown in this menu and is valid for 60 minutes.
4. If you do not already have an account, register in the mobile app or on myuplink.com.
5. Use the connection string to connect your installation to your user account on myUplink.

Range of services

myUplink gives you access to various levels of service. The base level is included and, apart from this, you can choose two premium services for a fixed annual fee (the fee varies depending on the functions selected).

Service level	Basic	Premium extended history	Premium change settings
Viewer	X	X	X
Alarm	X	X	X
History	X	X	X
Extended history	-	X	-
Manage	-	-	X

myUplink PRO

myUplink PRO is a complete tool for offering service agreements to the end customer and for always having the latest information about the installation, as well as the option to adjust settings remotely.

With myUplink PRO, you can provide your connected customers with rapid status and remote diagnostics.

Visit pro.myuplink.com for information about what else you can do using the mobile app and online.

Control - Introduction

Display unit

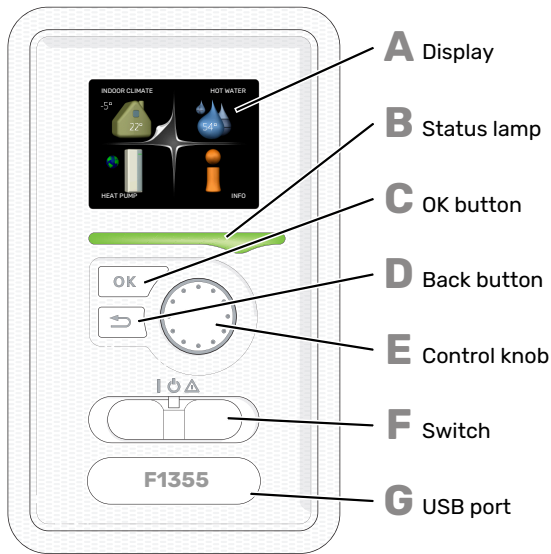

A DISPLAY
Instructions, settings and operational information are shown on the display. You can easily navigate between the different menus and options to set the comfort or obtain the information you require.

B STATUS LAMP
The status lamp indicates the status of the heat pump. It:

- lights green during normal operation.
- lights yellow in emergency mode.
- lights red in the event of a deployed alarm.

C OK BUTTON
The OK button is used to:

- confirm selections of sub menus/options/set values/page in the start guide.

D BACK BUTTON
The back button is used to:

- go back to the previous menu.
- change a setting that has not been confirmed.

E CONTROL KNOB
The control knob can be turned to the right or left. You can:

- scroll in menus and between options.
- increase and decrease the values.
- change page in multiple page instructions (for example help text and service info).

F SWITCH
The switch assumes three positions:

- On (I)
- Standby (U)
- Emergency mode (Δ)

Emergency mode must only be used in the event of a fault on the heat pump. In this mode, the compressor switches off and the immersion heater engages. The heat pump display is not illuminated and the status lamp illuminates yellow.

G USB PORT
The USB port is hidden beneath the plastic badge with the product name on it.

The USB port is used to update the software.

Visit myuplink.com and click the "Software" tab to download the latest software for your installation.

Menu system

When the door to the heat pump is opened, the menu system's four main menus are shown in the display as well as certain basic information.

MASTER

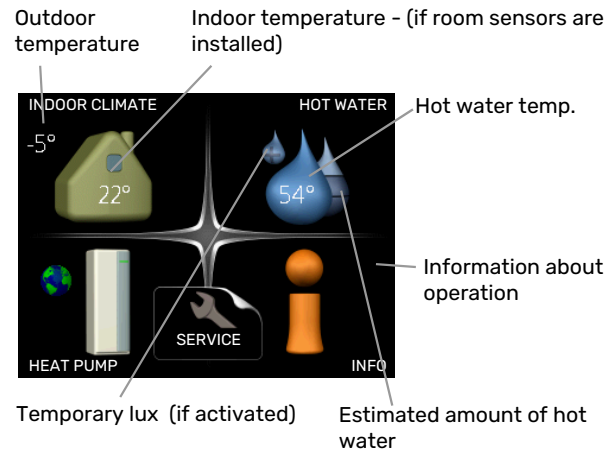

SLAVE

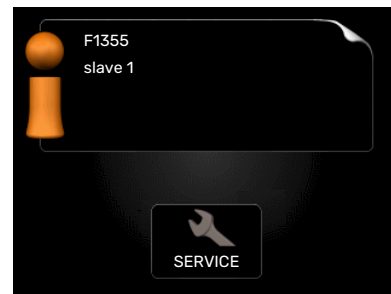

If the heat pump is set as slave a limited main menu is displayed because the majority of the settings for the system are made at the master heat pump.

MENU 1 - INDOOR CLIMATE

Setting and scheduling the indoor climate. See page 13.

MENU 2 - HOT WATER

Setting and scheduling hot water production. See page 21.

This menu only appears if a water heater is docked to the heat pump.

This menu is also set in the slave heat pump's limited menu system.

MENU 3 - INFO

Display of temperature and other operating information and access to the alarm log. See page 24.

This menu is also set in the slave heat pump's limited menu system.

MENU 4 - HEAT PUMP

Setting time, date, language, display, operating mode etc.
See page 26.











MENU 5 - SERVICE

Advanced settings. These settings are only intended for installers or service engineers. The menu is visible when the Back button is pressed for 7 seconds, when you are in the start menu. See page 35.

This menu is also set in the slave heat pump's limited menu system.

SYMBOLS IN THE DISPLAY

The following symbols may appear on the display during operation.

Symbol	Description
	This symbol appears by the information sign if there is information in menu 3.1 that you should note.
	<p>These two symbols indicate whether the compressor or addition is blocked in F1355.</p> <p>These can, for example, be blocked depending on which operating mode is selected in menu 4.2, if blocking is scheduled in menu 4.9.5 or if an alarm has occurred that blocks one of them.</p> <p> Blocking the compressor.</p> <p> Blocking additional heat.</p>
	This symbol appears if periodic increase or lux mode for the hot water is activated.
	This symbol indicates whether "holiday setting" is active in 4.7.
	This symbol indicates whether F1355 has contact with myUplink.
	This symbol indicates the actual speed of the fan if the speed has changed from the normal setting. Accessory needed.
	This symbol is visible in installations with active solar accessories.
	This symbol indicates whether pool heating is active. Accessory needed.
	This symbol indicates whether cooling is active. Accessory needed.

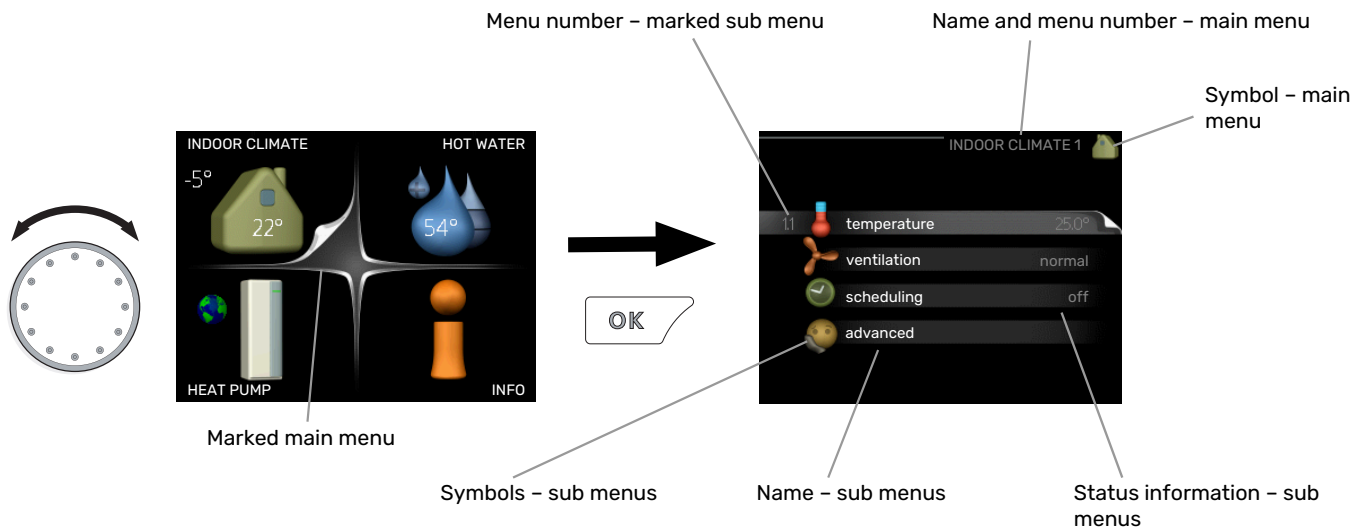

OPERATION

To move the cursor, turn the control knob to the left or the right. The marked position is white and/or has a turned up tab.



SELECTING MENU

To advance in the menu system select a main menu by marking it and then pressing the OK button. A new window then opens with sub menus.

Select one of the sub menus by marking it and then pressing the OK button.

SETTING A VALUE



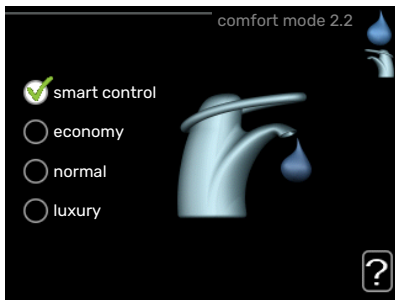

Values to be changed

SELECTING OPTIONS



In an options menu the current selected option is indicated by a green tick. 

To select another option:

1. Mark the applicable option. One of the options is pre-selected (white). 
2. Press the OK button to confirm the selected option. The selected option has a green tick. 

To set a value:

1. Mark the value you want to set using the control knob. 01
2. Press the OK button. The background of the value becomes green, which means that you have accessed the setting mode. 01
3. Turn the control knob to the right to increase the value and to the left to reduce the value. 04
4. Press the OK button to confirm the value you have set. To change and return to the original value, press the Back button. 04

USE THE VIRTUAL KEYBOARD

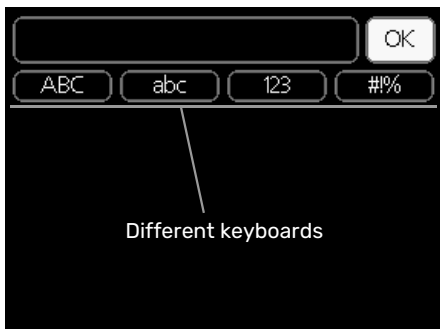

In some menus where text may require entering, a virtual keyboard is available.

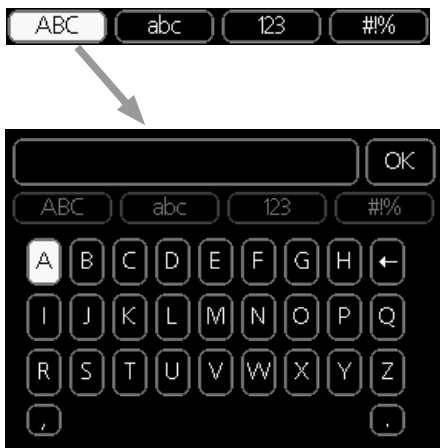

Depending on the menu, you can gain access to different character sets which you can select using the control knob. To change character table, press the Back button. If a menu only has one character set the keyboard is displayed directly. When you have finished writing, mark "OK" and press the OK button.

SCROLL THROUGH THE WINDOWS

A menu can consist of several windows. Turn the control knob to scroll between the windows.

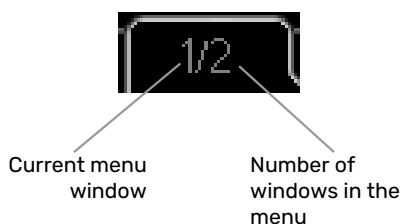

Scroll through the windows in the start guide



Arrows to scroll through window in start guide

1. Turn the control knob until one of the arrows in the top left corner (at the page number) has been marked.
2. Press the OK button to skip between the steps in the start guide.

HELP MENU

 In many menus there is a symbol that indicates that extra help is available.

To access the help text:

1. Use the control knob to select the help symbol.
2. Press the OK button.

The help text often consists of several windows that you can scroll between using the control knob.

Control - Menus

Menu 1 – INDOOR CLIMATE

OVERVIEW

1 - INDOOR CLIMATE	1.1 - temperature	1.1.1 - temperature heating	
		1.1.2 - temperature cooling *	
		1.1.3 - rel. humidity *	
	1.2 - ventilation		
	1.3 - scheduling	1.3.1 - scheduling heating	
		1.3.2 - scheduling cooling *	
		1.3.2 - scheduling ventilation *	
	1.9 - advanced	1.9.1 - curve	1.9.1.1 heating curve
			1.9.1.2 - cooling curve *
		1.9.2 - external adjustment	
	1.9.3 - min. flow line temp.	1.9.3.1 - min. flow line temp. heating	
		1.9.3.2 - min. flow line temp. cooling *	
	1.9.4 - room sensor settings		
	1.9.5 - cooling settings *		
	1.9.6 - fan return time *		
	1.9.7 - own curve	1.9.7.1 - own heating curve	
		1.9.7.2 - own cooling curve *	
	1.9.8 - point offset		
	1.9.9 - night cooling*		

* Accessories are needed.

Sub-menus

For the menu **INDOOR CLIMATE** there are several sub-menus. Status information for the relevant menu can be found on the display to the right of the menus.

temperature Setting the temperature for the climate system. The status information shows the set values for the climate system.

ventilation Setting the fan speed. The status information shows the selected setting. This menu is only displayed if the exhaust air module is connected (accessory).

scheduling Scheduling heating, cooling and ventilation. Status information "set" is displayed if you set a schedule but it is not active now, "holiday setting" is displayed if the vacation schedule is active at the same time as the schedule (the vacation function is prioritised), "active" displays if any part of the schedule is active, otherwise it displays " off".

advanced Setting of heat curve, adjusting with external contact, minimum value for supply temperature, room sensor and cooling function.

MENU 1.1 - TEMPERATURE

If the house has several climate systems, this is indicated on the display by a thermometer for each system.

Choose between heating or cooling and then set the desired temperature in the next menu "temperature heating/cooling" in menu 1.1.

Set the temperature (with room sensor installed and activated):

heating

Setting range: 5 – 30 °C

Default value: 20

cooling (accessory is required)

Setting range: 5 – 30 °C

Default value: 25

The value in the display appears as a temperature in °C if the climate system is controlled by a room sensor.



NOTE!

A slow heat-releasing heating system, such as for example, underfloor heating, may not be suitable for control using the heat pump's room sensor.

To change the room temperature, use the control knob to set the desired temperature in the display. Confirm the new setting by pressing the OK button. The new temperature is shown on the right-hand side of the symbol in the display.

Setting the temperature (without room sensors activated):

Setting range: -10 to +10
Default value: 0

The display shows the set values for heating (curve offset). To raise or lower the indoor temperature, increase or reduce the value on the display.

Use the control knob to set a new value. Confirm the new setting by pressing the OK button.

The number of steps the value has to be changed to achieve a degree change of the indoor temperature depends on the heating installation. One step is usually enough but in some cases several steps may be required.

Setting the desired value. The new value is shown on the right-hand side of the symbol in the display.

NOTE!

An increase in the room temperature can be slowed by the thermostats for the radiators or under floor heating. Therefore, open the thermostats fully, except in those rooms where a cooler temperature is required, e.g. bedrooms.

TIP!

Wait 24 hours before making a new setting, so that the room temperature has time to stabilise.

If it is cold outdoors and the room temperature is too low, increase the curve slope in menu 1.9.1.1 by one increment.

If it is cold outdoors and the room temperature is too high, reduce the curve slope in menu 1.9.1.1 by one increment.

If it is warm outdoors and the room temperature is too low, increase the value in menu 1.1.1 by one increment.

If it is warm outdoors and the room temperature is too high, reduce the value in menu 1.1.1 by one increment.

MENU 1.2 - VENTILATION (ACCESSORY REQUIRED)

Setting range: normal and speed 1-4
Default value: normal

The ventilation in the accommodation can be temporarily increased or reduced here.

When you have selected a new speed a clock starts a count down. When the time has counted down the ventilation speed returns to the normal setting.

If necessary, the different return times can be changed in menu 1.9.6.

The fan speed is shown in brackets (in percent) after each speed alternative.

TIP!

If longer time changes are required use the holiday function or scheduling.

MENU 1.3 - SCHEDULING

In the menu **scheduling** indoor climate (heating/cooling/ventilation) is scheduled for each weekday.

You can also schedule a longer time during a selected period (holiday) in menu 4.7.

Schedule: The schedule to be changed is selected here.

Schedule setting

These settings can be made for each schedule (Menu 1.3.1, 1.3.2 and 1.3.3):

Activated: Scheduling for the selected period is activated here. Set times are not affected at deactivation.

System: The climate system that the relevant schedule relates to is selected here. This alternative is only displayed if there is more than one climate system.

Day: Select which day or days of the week the scheduling is to apply to here. To remove the scheduling for a particular day, the time for that day must be reset by setting the start time to the same as the stop time. If the row "all" is used, all days in the period are set according to that row.

Time period: The start and stop time for the selected day for scheduling are selected here.

Adjusting: See relevant sub menu.

Conflict: If two settings conflict with each other, a red exclamation mark is displayed.

TIP!

If you wish to set similar scheduling for every day of the week start by filling in "all" and then changing the desired days.

TIP!

Set the stop time earlier than the start time so that the period extends beyond midnight. Scheduling then stops at the set stop time the day after.

Scheduling always starts on the date that the start time is set for.

MENU 1.3.1 - HEATING

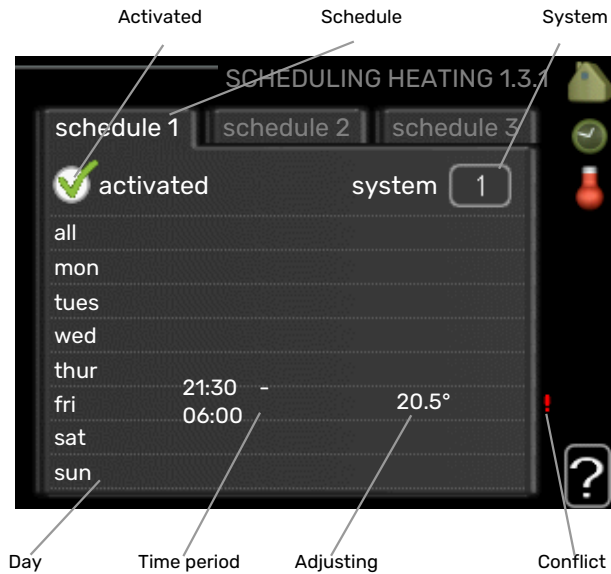

Increases or decreases in the accommodation temperature can be scheduled here for up to three time periods per day. If a room sensor is installed and activated the desired room temperature (°C) is set during the time period. Without an activated room sensor the desired change is set (of setting in menu 1.1). One step is usually enough to change the room temperature by one degree, but in some cases several steps may be required.

Adjustment: How much the heating curve is to be offset in relation to menu 1.1 during scheduling is set here. If a room sensor is installed, the desired room temperature is set in °C.

NOTE!

Changes of temperature in accommodation take time. For example, short time periods in combination with underfloor heating will not give a noticeable difference in room temperature.

MENU 1.3.2 - COOLING (ACCESSORY REQUIRED)

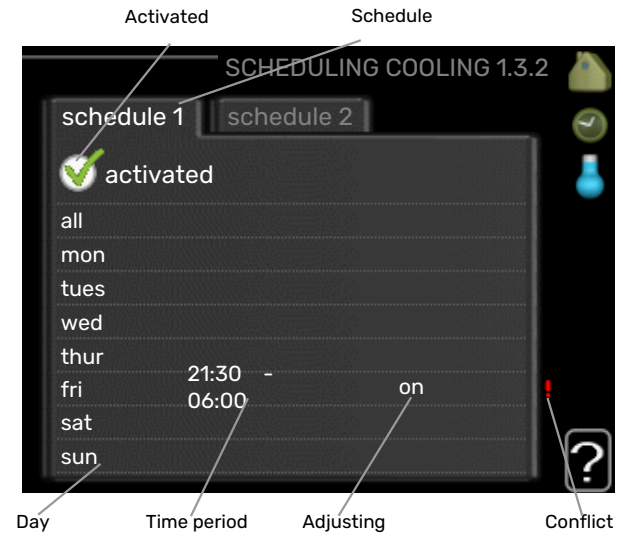

Here you can schedule when cooling is permitted in the accommodation for up to two different time periods per day.

Adjustment: Here, you schedule when cooling will not be permitted.

MENU 1.3.3 - VENTILATION (ACCESSORY REQUIRED)

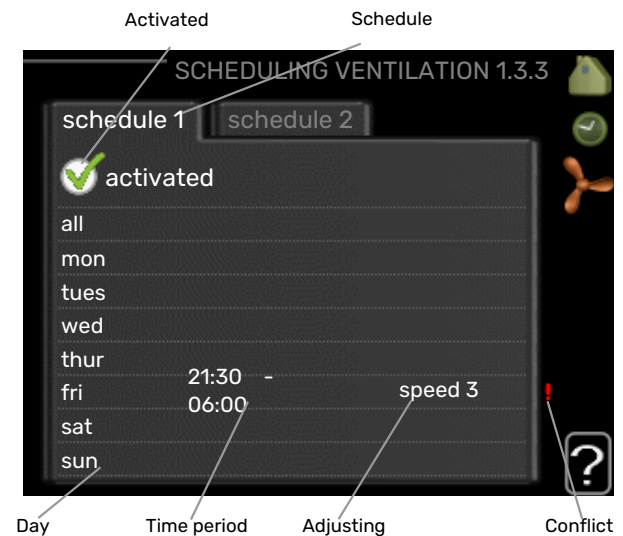

Increases or decreases in the ventilation to the accommodation can be scheduled here for up to two time periods per day.

Adjustment: The desired fan speed is set here.



NOTE!

A significant change over a longer period of time may cause poor indoor environment and worse operating economy.

MENU 1.9 - ADVANCED

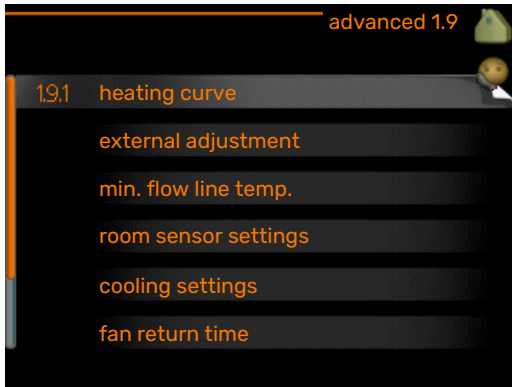

Menu **advanced** has orange text and is intended for the advanced user. This menu has several sub-menus.

curve Setting the curve slope for heating and cooling.

external adjustment Setting the heat curve offset when the external contact is connected.

min. flow line temp. Setting minimum permitted flow line temperature.

room sensor settings Settings regarding the room sensor.

cooling settings Settings for cooling.

fan return time Fan return time settings in the event of temporary ventilation speed change.

own curve Setting own curve for heating and cooling.

point offset Setting the offset of the heating curve or cooling curve at a specific outdoor temperature.

night cooling Setting night cooling.

MENU 1.9.1 - CURVE

heating curve

Setting range: 0 - 15

Default value: 9

cooling curve (accessory required)

Setting range: 0 - 9

Default value: 0

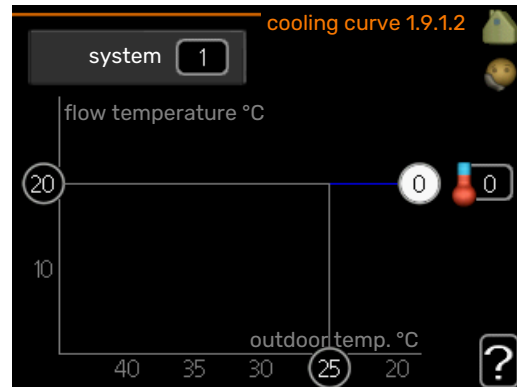
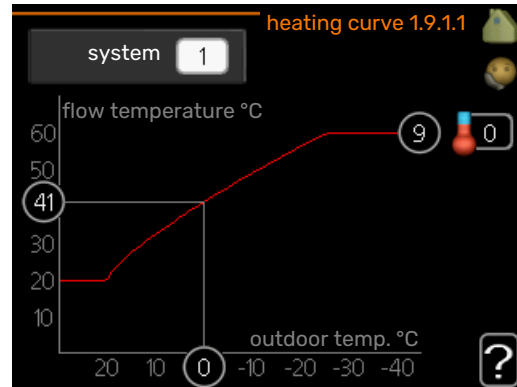

You can select heating or cooling in the **curve** menu. The next menu (heating curve/cooling curve) shows the heating and cooling curves for your house. The task of the curve is to give an even indoor temperature, regardless of the outdoor temperature, and thereby energy efficient operation. It is from these heat curves that the heat pump's control computer determines the temperature of the water to the system, the supply temperature, and therefore the indoor temperature. Select the curve and read off how the supply temperature changes at different outdoor temperatures here. The number to the far right of "system" displays which system you have selected the heating curve/cooling curve for.



NOTE!

With underfloor heating systems, **max flow line temperature** should normally be set to between 35 and 45 °C.

With underfloor cooling, "min. flow line temp." must be restricted to prevent condensation.

Check the max temperature for your floor with your installer/floor supplier.



TIP!

Wait 24 hours before making a new setting, so that the room temperature has time to stabilise.

If it is cold outdoors and the room temperature is too low, increase the curve slope by one increment.

If it is cold outdoors and the room temperature is too high, lower the curve slope by one increment.

If it is warm outdoors and the room temperature is too low, increase the curve offset by one increment.

If it is warm outdoors and the room temperature is too high, lower the curve offset by one increment.

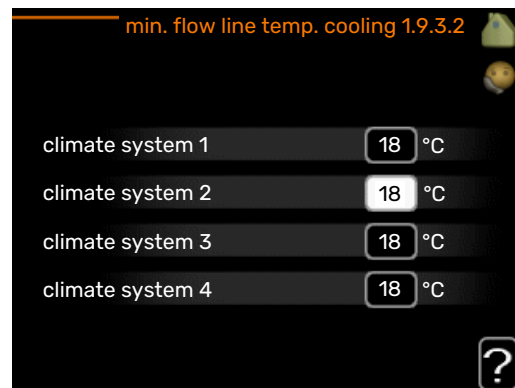
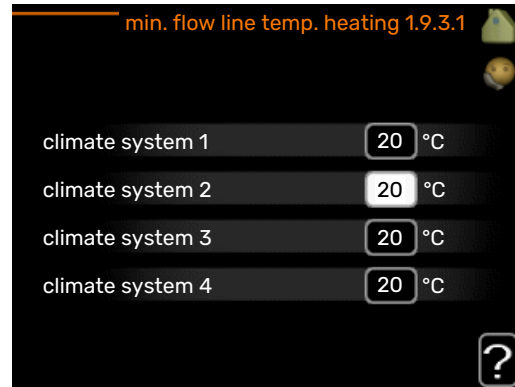

MENU 1.9.2 - EXTERNAL ADJUSTMENT

heating

climate system

Setting range: -10 to +10.

Default value: 0

cooling (accessory is required)

climate system

Setting range: -10 to +10.

Default value: 0

Connecting an external switch, for example a room thermostat or a timer, allows you to raise or lower the room temperature temporarily or periodically. When the switch is turned on, the heating curve or cooling curve offset is changed by the number of steps selected in the menu. If a room sensor is installed and activated, the desired room temperature (°C) is set.

If there is more than one climate system the setting can be made separately for each system.

MENU 1.9.3 - MIN. FLOW LINE TEMP.

heating

Setting range: 5-70 °C

Default value: 20 °C

cooling (accessory required)

Depending on which accessory is used the setting range can vary.

Factory setting: 18 °C

In menu 1.9.3 you select heating or cooling, in the next menu (min. supply temp.heating/cooling) set the minimum temperature on the supply temperature to the climate system. This means that F1355 never calculates a temperature lower than that set here.

If there is more than one climate system the setting can be made separately for each system.



TIP!

The value can be increased if you have, for example, a cellar that you always want to heat, even in summer.

You may also need to increase the value in "stop heating" menu 4.9.2 "auto mode setting".

MENU 1.9.4 - ROOM SENSOR SETTINGS

factor system

heating

Setting range: 0.0 - 6.0

Factory setting heating: 1.0

cooling (accessory required)

Setting range: 0.0 - 6.0

Factory setting cooling: 1.0

Room sensors to control the room temperature can be activated here.

NOTE!

A slow heating system such as underfloor heating may not be suitable for control using the installation's room sensors.

Here you can set a factor (a numerical value) that determines how much an over or sub normal temperature (the difference between the desired and actual room temperature) in the room is to affect the supply temperature to the climate system. A higher value gives a greater and faster change of the heating curve's set offset.



CAUTION!

Too high a set value for "factor system" can (depending on your climate system) produce an unstable room temperature.

If several climate systems are installed the above settings can be made for the relevant systems.

MENU 1.9.5 - COOLING SETTINGS (ACCESSORY REQUIRED)

cool/heat sensor

Factory setting: no sensor selected

set pt value cool/heat sensor

Setting range: 5 - 40 °C

Default value: 21

heat at room under temp.

Setting range: 0.5 - 10.0 °C

Default value: 1.0

cool at room over temp.

Setting range: 0.5 - 10.0 °C

Default value: 3.0

alarm rumsgivare kyla

Setting range: on/off

Factory setting: off

start passive cooling

Setting range: 10 - 200

Factory setting: 30 DM

start active cooling

Setting range: 30 - 300 DM

Factory setting: 30 DM

degree minutes cooling

Setting range: -3000 - 3000 cooling degree minutes

Factory setting: 0

heat dump 24h-function

Setting range: on/off

Factory setting: off

closingtime for cool dump

Setting range: 0 - 100 s

Factory setting: 0 s

max compr. in active cooling

Setting range: 0 - 18

Factory setting: 18

time betw. switch heat/cool

Setting range: 0 - 48 h

Factory setting: 2

mixing valve amplifier

Setting range: 0.1 - 10.0

Default value: 1.0

mixing valve step delay

Setting range: 10 - 300 s

Setting range: 10 - 500 s

Default values: 30 s

You can use F1355 to cool the house during hot periods of the year.



NOTE!

Certain setting options only appear if their function is installed and activated in F1355.

cool/heat sensor

An extra temperature sensor can be connected to F1355 in order to determine when it is time to switch between heating and cooling operation.

When several heating/cooling sensors are installed, you can select which one of them should be in control.



NOTE!

When the heating/cooling sensors BT74 have been connected and activated in menu 5.4, no other sensor can be selected in menu 1.9.5.

set pt value cool/heat sensor

Here you can set at which indoor temperature F1355 is to shift between heating respectively cooling operation.

heat at room under temp.

Here you can set how far the room temperature can drop below the desired temperature before F1355 switches to heating operation.

cool at room over temp.

Here you can set how high the room temperature can increase above the desired temperature before F1355 switches to cooling operation.

alarm rumsgivare kyla

This is where you set whether F1355 is to initiate an alarm if the room sensor is disconnected or breaks during cooling operation.

start passive cooling

Here you can set when passive cooling is to start.

Degree minutes are a measurement of the current heating demand in the house and determine when the compressor, cooling operation respectively additional heat will start/stop.

start active cooling

Here you can set when active cooling is to start.

Degree minutes are a measurement of the current heating demand in the house and determine when the compressor, cooling operation respectively additional heat will start/stop.

compressor speed

Here you can set at what speed the compressor is to operate at during active cooling. Set value corresponds to part of the available output.

degree minutes cooling

This selection is only available when the connected accessory itself counts cooling degree minutes.

After a min or max value has been set, the system will automatically set the real value in relation to the number of compressors that are running cooling.

time betw. switch heat/cool

This selection is only available when cooling in 2-pipe systems.

Here you can set how long F1355 is to wait before it returns to heating mode when the cooling demand has ceased or vice versa.

MENU 1.9.6 - FAN RETURN TIME (ACCESSORY REQUIRED)

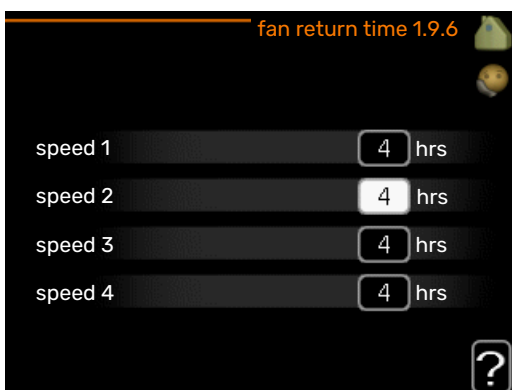

Here you select the return time for temporary speed change (speed 1-4) on the ventilation in menu 1.2.

Return time is the time it takes before ventilation speed returns to normal.

MENU 1.9.7 - OWN CURVE

supply temperature

heating

Setting range: 5 – 80 °C

cooling (accessory required)

Depending on which accessory is used the setting range can vary.

Setting range: 5 – 40 °C

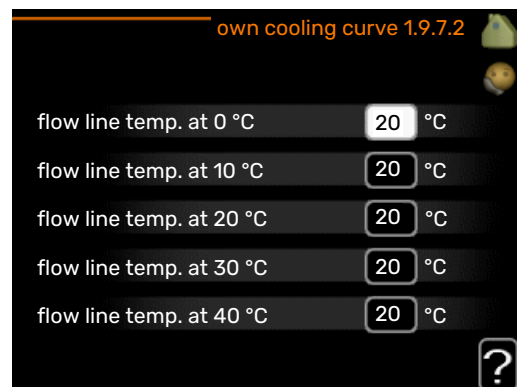
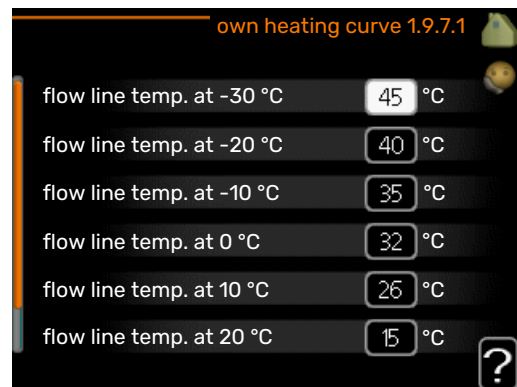

When required, create your own heating or cooling curve here, by setting the desired supply temperatures for different outdoor temperatures.



NOTE!

Curve 0 in menu 1.9.1 must be selected for own curve to apply.

MENU 1.9.8 - POINT OFFSET

outdoor temp. point

Setting range: -40 – 30 °C

Default value: 0 °C

change in curve

Setting range: -10 – 10 °C

Default value: 0 °C

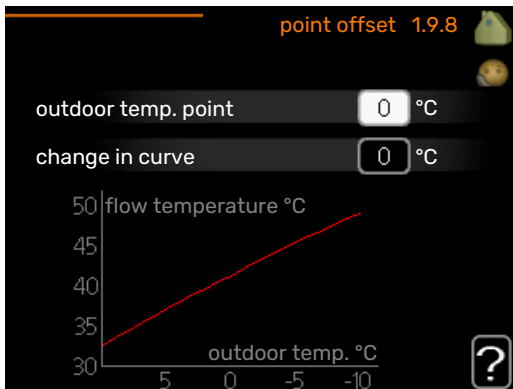

NOTE!

Night cooling can only be activated when house heating has been deactivated. This is done in menu 4.2.

Select a change in the heating curve at a certain outdoor temperature here. One step is usually enough to change the room temperature by one degree, but in some cases several steps may be required.

The heat curve is affected at $\pm 5^\circ\text{C}$ from set outdoor temp. point.

It is important that the correct heating curve is selected so that the room temperature is experienced as even.



TIP!

If it is cold in the house, at, for example -2°C , "outdoor temp. point" is set to "-2" and "change in curve" is increased until the desired room temperature is maintained.



NOTE!

Wait 24 hours before making a new setting, so that the room temperature has time to stabilise.

MENU 1.9.9 - NIGHT COOLING (ACCESSORY REQUIRED)

start temp. exhaust air

Setting range: $20 - 30^\circ\text{C}$

Default value: 25°C

min diff. outdoor-exhaust

Setting range: $3 - 10^\circ\text{C}$

Default value: 6°C

Activate night cooling here.

When the temperature in the house is high and the outdoor temperature is lower, a cooling effect can be obtained by forcing the ventilation.

If the temperature difference between the exhaust air and the outdoor air temperature is greater than the set value ("min diff. outdoor-exhaust") and the exhaust air temperature is higher than the set value ("start temp. exhaust air"), run the ventilation at speed 4 until one of the conditions is no longer met.

Menu 2 – HOT WATER

OVERVIEW

2 - HOT WATER*, **	2.1 - temporary lux	
	2.2 - comfort mode	
	2.3 - scheduling	
	2.9 - advanced	2.9.1 - periodic increase
		2.9.2 - hot water recirc. *

* Accessory needed.

** This menu is also set in the slave heat pump's limited menu system.

Sub-menus

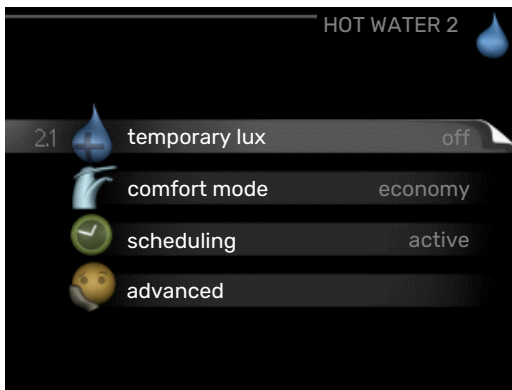

This menu only appears if a water heater is docked to the heat pump.

For the menu **HOT WATER** there are several sub-menus. Status information for the relevant menu can be found on the display to the right of the menus.

temporary lux Activation of temporary increase in the hot water temperature. Status information displays "off" or what length of time of the temporary temperature increase remains.

comfort mode Setting hot water comfort. The status information displays what mode is selected, "economy", "normal" or "luxury".

scheduling Scheduling hot water comfort. The status information "set" appears if you have set scheduling but it is not currently active, "holiday setting" appears if holiday setting is active at the same time as scheduling (when the holiday function is prioritised), "active" appears if any part of scheduling is active, otherwise "off" appears.

advanced Setting periodic increase in the hot water temperature.

MENU 2.1 - TEMPORARY LUX

Setting range: 3, 6 and 12 hours and mode "off" and "one time increase"
 Default value: "off"

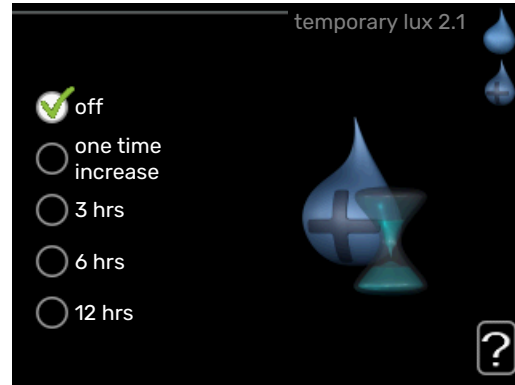

When hot water requirement has temporarily increased this menu can be used to select an increase in the hot water temperature to lux mode for a selectable time.



NOTE!

If comfort mode "luxury" is selected in menu 2.2 no further increase can be carried out.

The function is activated immediately when a time period is selected and confirmed using the OK button. The remaining time for the selected setting is shown to the right.

When the time has run out F1355 returns to the mode set in menu 2.2.

Select "off" to switch off **temporary lux**.

MENU 2.2 - COMFORT MODE

Setting range: smart control, economy, normal, luxury
 Default value: normal

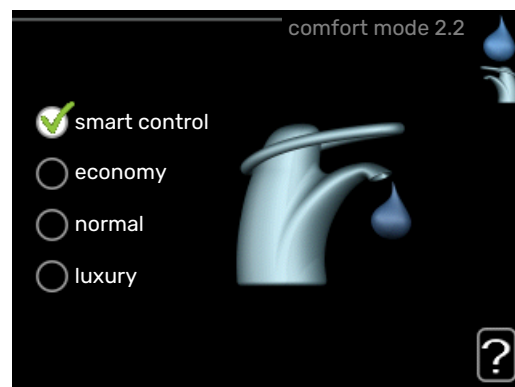

The difference between the selectable modes is the temperature of the hot tap water. Higher temperature means that the hot water lasts longer.

smart control: With smart control activated, the F1355 learns the previous week's hot water consumption and adapts the temperature in the water heater for the coming week to ensure minimal energy consumption.

If the hot water demand is greater, there is a certain additional amount of hot water available.

economy: This mode produces less hot water than the others, but is more economical. This mode can be used in smaller households with a small hot water requirement.

normal: Normal mode gives a larger amount of hot water and is suitable for most households.

luxury: Lux mode gives the greatest possible amount of hot water. In this mode, the immersion heater may be partially used to heat hot water, which increases operating costs.

MENU 2.3 - SCHEDULING

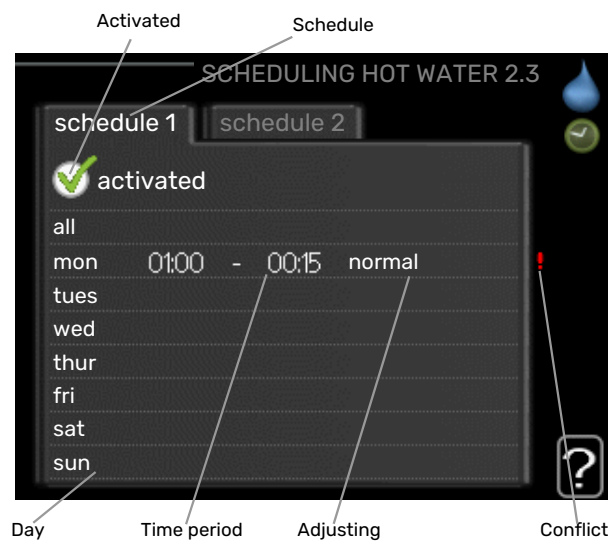

What hot water comfort the heat pump is to work with can be scheduled here for up to two different time periods per day.

Scheduling is activated/deactivated by ticking/unticking "activated". Set times are not affected at deactivation.

Schedule: The schedule to be changed is selected here.

Activated: Scheduling for the selected period is activated here. Set times are not affected at deactivation.

Day: Select which day or days of the week the scheduling is to apply to here. To remove the scheduling for a particular day, the time for that day must be reset by setting the start time to the same as the stop time. If the row "all" is used, all days in the period are set according to that row.

Time period: The start and stop time for the selected day for scheduling are selected here.

Adjustment: Set the hot water comfort that is to apply during scheduling here.

Conflict: If two settings conflict with each other, a red exclamation mark is displayed.

TIP!

If you wish to set similar scheduling for every day of the week start by filling in "all" and then changing the desired days.

TIP!

Set the stop time earlier than the start time so that the period extends beyond midnight. Scheduling then stops at the set stop time the day after.

Scheduling always starts on the date that the start time is set for.

MENU 2.9 - ADVANCED

Menu **advanced** has orange text and is intended for the advanced user. This menu has several sub-menus.

MENU 2.9.1 - PERIODIC INCREASE

period

Setting range: 1 - 90 days

Factory setting: 7 days

start time

Setting range: 00:00 - 23:00

Default value: 00:00

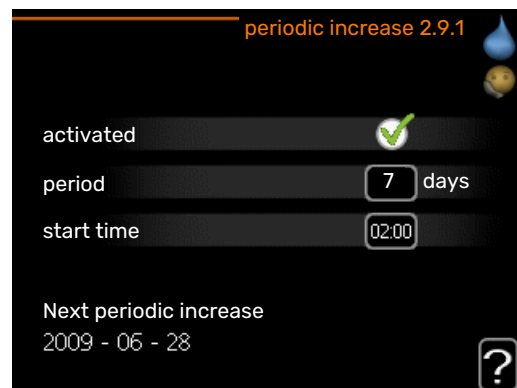

To prevent bacterial growth in the water heater, the compressor and the immersion heater can increase the hot water temperature for a short time at regular intervals.

Here, you can select the length of time between increases in the hot water temperature. The time can be set between 1 and 90 days. Factory setting is 7 days. Tick/untick "activated" to start/switch off the function.

MENU 2.9.2 - HOT WATER RECIRC. (ACCESSORY REQUIRED)

operating time

Setting range: 1 - 60 min

Default value: 60 min

downtime

Setting range: 0 - 60 min

Default value: 0 min

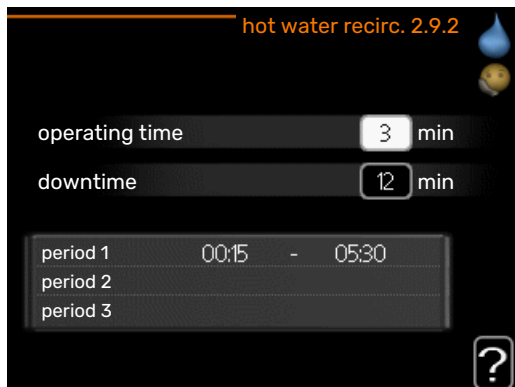

Set the hot water circulation for up to three periods per day here. During the set periods the hot water circulation pump will run according to the settings above.

"operating time" decide how long the hot water circulation pump must run per operating instance.

"downtime" decide how long the hot water circulation pump must be stationary between operating instances.

Menu 3 – INFO

OVERVIEW

3 - INFO **	3.1 - service info **
	3.2 - compressor info **
	3.3 - add. heat info **
	3.4 - alarm log **
	3.5 - indoor temp. log
	3.6 - energy log

** This menu is also set in the slave heat pump's limited menu system.

Sub-menus

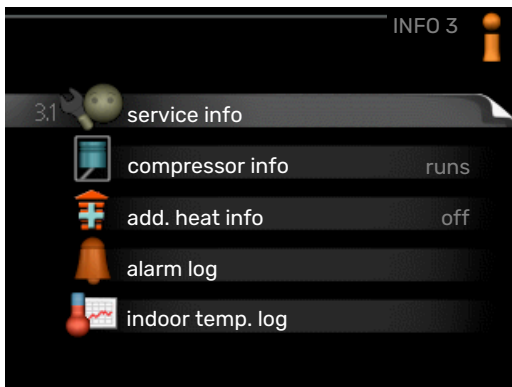

For the menu **INFO** there are several sub-menus. No settings can be made in these menus, they just display information. Status information for the relevant menu can be found on the display to the right of the menus.

service info shows temperature levels and settings in the installation.

compressor info shows operating times, number of starts etc for the compressor in the heat pump.

add. heat info displays information about the additional heat's operating times etc.

alarm log displays the latest alarm and information about the heat pump when the alarm occurred.

indoor temp. log the average temperature indoors week by week during the past year.

energy log the energy consumption month by month over the past year as well as the energy consumption year by year.

MENU 3.1 - SERVICE INFO

Information about the actual operating status of the installation (e.g. current temperatures etc.) can be obtained here. If multiple heat pumps are connected as master/slave, information about them is also shown in this menu. No changes can be made. The information is on several pages. Turn the control knob to scroll between the pages.

A QR code appears on one side. This QR code indicates serial number, product name and limited operating data.

This menu is also set in the slave heat pump's limited menu system.

Symbols in this menu:			
	Compressors EP14/EP15 (cooling module) displays which compressor is operating.		Heating A digit displays how many compressors (if more than one) are currently working with heating operation.
	Internally connected external additional heat and external additional heat connected via accessory.		Hot water A digit displays how many compressors (if more than one) are currently working with hot water charging.
	Brine pumps (blue)		Heating medium pumps (orange) EP14/EP15 (cooling module) displays which circulation pump is operating.
	Cooling A digit displays how many compressors (if more than one) are currently working with cooling operation.		Pool A digit displays how many compressors (if more than one) are currently working with pool heating.
	Ventilation		Solar accessory

MENU 3.2 - COMPRESSOR INFO

Information about the compressors' operating status and statistics in the installation can be obtained here. No changes can be made.

If several heat pumps are connected as master/slave, information about the other heat pumps' compressors is also shown in a tab system.

This menu is also set in the slave heat pump's limited menu system.

MENU 3.3 - ADD. HEAT INFO

Information about the additional heat's settings, operating status and statistics can be obtained here. No changes can be made.

The information is on several pages. Turn the control knob to scroll between the pages.

MENU 3.4 - ALARM LOG

To facilitate fault-finding the heat pump operating status at alarm alerts is stored here. You can see information for the 10 most recent alarms.

This menu is also set in the slave heat pump's limited menu system.

To view the run status in the event of an alarm, mark the alarm and press the OK button.

MENU 3.5 - INDOOR TEMP. LOG

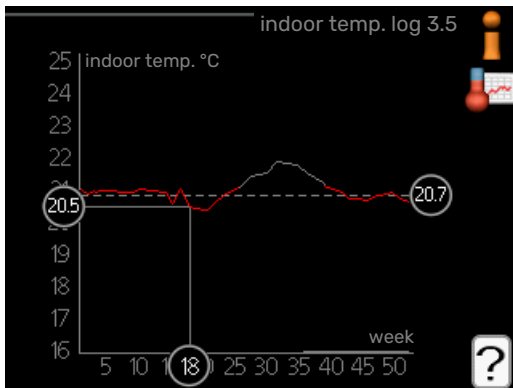

Here you can see the average temperature indoors week by week during the past year. The dotted line indicates the annual average temperature.

The average outdoor temperature is only shown if a room temperature sensor/room unit is installed.

When an exhaust air module (NIBE FLM) is installed, the exhaust air temperature is shown.

To read off an average temperature

1. Turn the control knob so that the ring on the shaft with the week number is marked.
2. Press the OK button.
3. Follow the grey line up to the graph and out to the left to read off the average indoor temperature at the selected week.
4. You can now select to take read outs for different weeks by turning the control knob to the right or left and read off the average temperature.
5. Press the OK or Back button to exit read off mode.

MENU 3.6 - ENERGY LOG

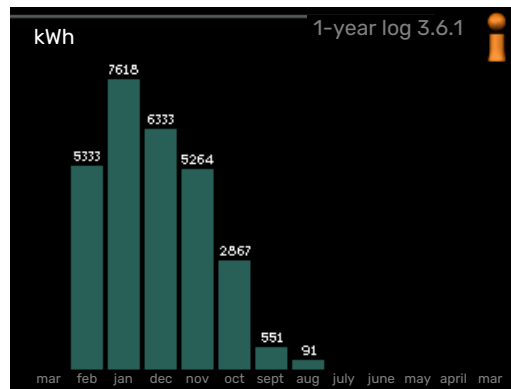

Here, you can see the energy consumption month by month over the past year as well as energy consumption year by year.

Menu 4 – HEAT PUMP

OVERVIEW

4 - HEAT PUMP	4.1 - plus functions *	4.1.1 - pool 1 *	
		4.1.2 - pool 2 *	
		4.1.3 - internet	4.1.3.1 - myUplink
			4.1.3.8 - tcp/ip settings
			4.1.3.9 - proxy settings
		4.1.4 - sms *	
		4.1.5 - SG Ready	
		4.1.6 - smart price adaption	
		4.1.8 - smart energy source™	4.1.8.1 - settings
			4.1.8.2 - set. price
			4.1.8.3 - CO2 impact
			4.1.8.4 - tariff periods, electricity
			4.1.8.5 - tariff periods, fixed price
			4.1.8.6 - tariff per, ext. shunt add
			4.1.8.7 - tariff per, ext. step add
			4.1.8.8 - tariff periods, OPT10
		4.1.11 - demand-contr. ventil. *	
	4.2 - op. mode		
	4.3 - my icons		
	4.4 - time & date		
	4.6 - language		
	4.7 - holiday setting		
	4.9 - advanced	4.9.1 - op. prioritisation	
		4.9.2 - auto mode setting	
		4.9.3 - degree minute setting	
		4.9.4 - factory setting user	
		4.9.5 - schedule blocking	

* Accessory needed.

Sub-menus

For the menu **HEAT PUMP** there are several sub-menus. Status information for the relevant menu can be found on the display to the right of the menus.

plus functions Settings applying to any installed extra functions in the heating system.

op. mode Activation of manual or automatic operating mode. The status information shows the selected operating mode.

my icons Settings regarding which icons in the heat pump's user interface that are to appear in the slot when the door is closed.

time & date Setting current time and date.

language Select the language for the display here. The status information shows the selected language.

holiday setting Vacation scheduling heating, hot water and ventilation. Status information "set" is displayed if you set a vacation schedule but it is not active at the moment, "active" is displayed if any part of the vacation schedule is active, otherwise it displays " off".

advanced Setting heat pump work mode.

MENU 4.1 - PLUS FUNCTIONS

Settings for any additional functions installed in F1355 can be made in the sub menus.

MENU 4.1.1 - 4.1.2 - POOL 1 - POOL 2 (ACCESSORY IS REQUIRED)

start temp

Setting range: 5.0 - 80.0 °C

Default value: 22.0 °C

stop temperature

Setting range: 5.0 - 80.0 °C

Default value: 24.0 °C

compressor speed

Setting range: 1 - 100 %

Factory setting: 1 %

Select whether the pool control is to be activated, within what temperatures (start and stop temperature) pool heating must occur and how many compressors may work against the pool at the same time.

Here you can also set at what speed the compressor is to operate during pool heating. Set value corresponds to part of the available output.

When the pool temperature drops below the set start temperature and there is no hot water or heating requirement, F1355 starts pool heating.

Untick "activated" to switch off the pool heating.

NOTE!

The start temperature cannot be set to a value that is higher than the stop temperature.

MENU 4.1.3 - INTERNET

Here, you make settings for connecting F1355 to the internet, via myUplink.



CAUTION!

For these functions to work the network cable must be connected.

MENU 4.1.3.1 - MYUPLINK



Here you can manage the installation's connection to myUplink (myuplink.com) and see the number of users connected to the installation via the internet.

A connected user has a user account in myUplink, which has been given permission to control and/or monitor your installation.

Request new connection string

To connect a user account on myUplink to your installation, you must request a unique connection code.

1. Mark "request new connection string" and press the OK button.
2. The installation now communicates with myUplink to create a connection code.
3. When a connection string has been received, it is shown in this menu at "connection string" and is valid for 60 minutes.

Disconnect all users

1. Mark "switch off all users" and press the OK button.
2. The installation now communicates with myUplink to release your installation from all users connected via the internet.



CAUTION!

After disconnecting all users none of them can monitor or control your installation via myUplink without requesting a new connection string.

MENU 4.1.3.8 - TCP/IP SETTINGS



Here, you can set TCP/IP settings for your installation.

Automatic setting (DHCP)

1. Tick "automatic". The installation now receives the TCP/IP settings using DHCP.
2. Mark "confirm" and press the OK button.

Manual setting

1. Untick "automatic", you now have access to several setting options.
2. Mark "ip-address" and press the OK button.
3. Enter the correct details via the virtual keypad.
4. Select "OK" and press the OK button.
5. Repeat 1 - 3 for "net mask", "gateway" and "dns".
6. Mark "confirm" and press the OK button.



NOTE!

The installation cannot connect to the internet without the correct TCP/IP settings. If unsure about applicable settings use the automatic mode or contact your network administrator (or similar) for further information.



TIP!

All settings made since opening the menu can be reset by marking "reset" and pressing the OK button.

MENU 4.1.3.9 - PROXY SETTINGS

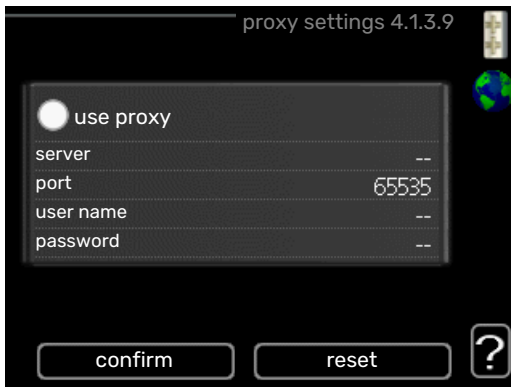

You can set proxy settings for your installation here.

Proxy settings are used to give connection information to a intermediate server (proxy server) between the installation and Internet. These settings are primarily used when the installation connects to the Internet via a company network. The installation supports proxy authentication of the HTTP Basic and HTTP Digest type.

If unsure about applicable settings, contact your network administrator (or equivalent) for further information.

Setting

1. Tick "use proxy" if you do not want to use a proxy.
2. Mark "server" and press the OK button.
3. Enter the correct details via the virtual keypad.
4. Select "OK" and press the OK button.
5. Repeat 1 - 3 for "port", "user name" and "password".
6. Mark "confirm" and press the OK button.



TIP!

All settings made since opening the menu can be reset by marking "reset" and pressing the OK button.

MENU 4.1.5 - SG READY

This function can only be used in mains networks that support the "SG Ready"-standard .

Make settings for the function "SG Ready" here.

affect room temperature

Here you set whether room temperature should be affected when activating "SG Ready".

With low price mode on "SG Ready" the parallel offset for the indoor temperature is increased by "+1". If a room sensor is installed and activated, the desired room temperature is instead increased by 1 °C.

With over capacity mode on "SG Ready" the parallel offset for the indoor temperature is increased by "+2". If a room sensor is installed and activated, the desired room temperature is instead increased by 2 °C.

affect hot water

Here you set whether the temperature of the hot water should be affected when activating "SG Ready".

With low price mode on "SG Ready", the stop temperature for the hot water is set as high as possible with compressor operation only (immersion heater not permitted).

With over capacity mode of "SG Ready" the hot water is set to "luxury" (immersion heater permitted).

affect cooling (accessory required)

Here you set whether room temperature during cooling operation should be affected when activating "SG Ready".

With low price mode of "SG Ready" and cooling operation the indoor temperature is not affected.

With over capacity mode on "SG Ready" and cooling operation, the parallel offset for the indoor temperature is reduced by "-1". If a room sensor is installed and activated, the desired room temperature is instead reduced by 1 °C.

affect pool temperature (accessory is required)

Here you set whether pool temperature should be affected when activating "SG Ready".

With low price mode on "SG Ready", the desired pool temperature (start and stop temperature) is increased by 1 °C.

With over capacity mode on "SG Ready" the desired pool temperature (start and stop temperature) is increased by 2 °C



CAUTION!

The function must be connected to two AUX inputs and activated in menu 5.4.

MENU 4.1.6 - SMART PRICE ADAPTION™

activated

This function can only be used if you have an hourly tariff agreement with your electricity supplier that supports Smart price adaption™ and you have an activated myUplink account.

area

Here you select where (which zone) the heat pump is set-up.

Contact your electricity supplier to find out which zone digit to enter.

affect room temperature

Setting range: 1 - 10

Factory setting: 5

affect hot water

Setting range: 1 - 4

Factory setting: 2

affect pool temperature

Setting range: 1 - 10

Factory setting: 2

affect cooling

Setting range: 1 - 10

Factory setting: 3

price of electricity overview

Here you can obtain information on how the electricity price varies over up to three days.

In menu Smart price adaption™ you state where the heat pump is located and how great a role the electricity price should play. The greater the value, the greater the effect the electricity price has and the larger the possible savings, but at the same time there is an increased risk of affecting comfort.

Smart price adaption™ moves the heat pump's consumption over 24 hours to periods with the cheapest electricity tariff, which gives savings for hourly rate based electricity contracts. The function is based on hourly rates for the next 24 hours being retrieved via myUplink and therefore an internet connection and an account for myUplink are required.

Deselect "activated" to switch off Smart price adaption™.

MENU 4.1.8 - SMART ENERGY SOURCE™

settings

set. price

*CO2 impact**

tariff periods, electricity

*tariff periods, fixed price***

tariff per, ext. shunt add

tariff per, ext. step add

The function prioritises how / to what extent each docked energy source will be used. Here you can choose if the system is to use the energy source that is cheapest at the time. You can also choose if the system is to use the energy source that is most carbon neutral at the time.

*Select control method "CO₂" under settings to open this menu.

**Select "spot" under set. price to open this menu.

MENU 4.1.8.1 - SETTINGS

smart energy source™

Setting range: Off/On

Factory setting: Off

control method

Setting range: Price / CO₂

Factory setting: Price

MENU 4.1.8.2 - SET. PRICE

price, electricity

Setting range: spot, tariff, fixed price

Factory setting: fixed price

Setting range fixed price: 0-100,000*

price, extern shunt add.

Setting range: tariff, fixed price

Factory setting: fixed price

Setting range fixed price: 0-100,000*

price, extern step add.

Setting range: tariff, fixed price

Factory setting: fixed price

Setting range fixed price: 0-100,000*

Here you can choose whether the system is to exercise control based on the spot price, tariff control or a set price. The setting is made for each individual energy source. Spot price can only be used if you have an hourly tariff agreement with your electricity supplier.

*The currency varies depending on the country selected.

MENU 4.1.8.3 - CO2 IMPACT

CO2, electricity

Setting range: 0-5

Default value: 2.5

CO2, ext. shunted contr. add.

Setting range: 0-5

Default value: 1

CO2, ext. step contr. add.

Setting range: 0-5

Default value: 1

Here, you set the size of the carbon footprint for each energy source.

The carbon footprint is different for different energy sources. For example, the energy from solar cells and wind turbines can be considered carbon dioxide neutral and, therefore, has a low CO₂ impact. Energy from fossil fuels can be considered to have a higher carbon footprint and, therefore, has a higher CO₂ impact.

MENU 4.1.8.4 - TARIFF PERIODS, ELECTRICITY

Here you can use tariff control for the electric additional heat.

Set the lower tariff periods. It is possible to set two different date periods per year. Within these periods, it is possible to set up to four different periods on weekdays (Monday to Friday) or four different periods on weekends (Saturdays and Sundays).

MENU 4.1.8.5 - TARIFF PERIODS, FIXED PRICE

Here you can use tariff control for the fixed electricity cost.

Set the lower tariff periods. It is possible to set two different date periods per year. Within these periods, it is possible to set up to four different periods on weekdays (Monday to Friday) or four different periods on weekends (Saturdays and Sundays).

MENU 4.1.8.6 - TARIFF PER, EXT. SHUNT ADD

Here you can use tariff control for the external shunted additional heat.

Set the lower tariff periods. It is possible to set two different date periods per year. Within these periods, it is possible to set up to four different periods on weekdays (Monday to Friday) or four different periods on weekends (Saturdays and Sundays).

MENU 4.1.8.7 - TARIFF PER, EXT. STEP ADD

Here you can use tariff control for the external step controlled additional heat.

Set the lower tariff periods. It is possible to set two different date periods per year. Within these periods, it is possible to set up to four different periods on weekdays (Monday to Friday) or four different periods on weekends (Saturdays and Sundays).

MENU 4.1.10 - SOLAR ELECTRICITY (ACCESSORY IS REQUIRED)

affect room temperature

Setting range: on/off

Default values: off

affect hot water

Setting range: on/off

Default values: off

affect pool temperature¹

Setting range: on/off

Default values: off

prioritise domestic electricity

Setting range: on/off

Default values: off

This is where you set which part of your installation (room temperature, hot water temperature, pool temperature) is to benefit from the solar electricity surplus.

When the solar panels produce more electricity than F1355 requires, the temperature in the property is adjusted and/or the temperature of the hot water is increased.

EME

In this menu you can also make settings that are specific for your EME.

For EME 20, you can select whether you want domestic electricity to be prioritised ahead of room temperature and hot water, provided that an external energy meter is connected to F1355.

MENU 4.1.11 - DEMAND-CONTR. VENTIL. (ACCESSORY IS REQUIRED)

demand-contr. ventil.

Setting range: on/off

Factory setting: off

desired Rh%

Setting range: 35 - 75%

Factory setting: 50 %

When activating demand-controlled ventilation, the accessory HTS 40 is allowed to affect the ventilation in order to achieve the desired relative humidity, which is set under "desired Rh%".

MENU 4.2 - OP. MODE

op. mode

Setting range: auto, manual, add. heat only

Default value: auto

functions

Setting range: compressor, addition, heating, cooling

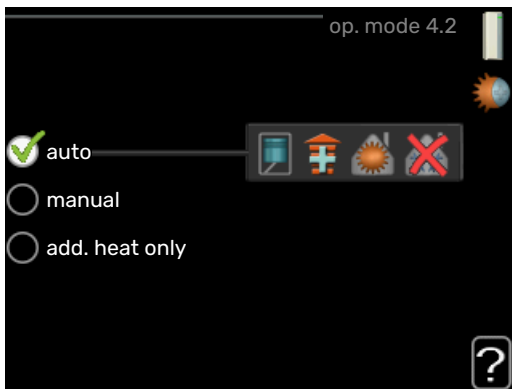

The heat pump operating mode is usually set to "auto". It is also possible to set the heat pump to "add. heat only", but only when an addition is used, or "manual" and select yourself what functions are to be permitted.

Change the operating mode by marking the desired mode and pressing the OK button. When an operating mode is selected, it shows what is permitted in the heat pump (crossed out = not permitted) and selectable alternatives to the right. To select selectable functions that are permitted or not, mark the function using the control knob and press the OK button.

Operating mode auto

In this operating mode the heat pump automatically selects what functions are permitted.

Operating mode manual

In this operating mode you can select what functions are permitted. You cannot deselect "compressor" in manual mode.

Operating mode add. heat only

In this operating mode the compressor is not active, only additional heat is used.

NOTE!

If you choose mode "add. heat only" the compressor is deselected and there is a higher operating cost.

Functions

"compressor" is the unit that produces heating and hot water for the home. If "compressor" is deselected in auto mode, this is displayed with a symbol in the main menu. You cannot deselect "compressor" in manual mode.

"addition" is the unit that helps the compressor to heat the home and/or the hot water when it cannot manage the entire requirement alone.

"heating" means you obtain heating in the home. You can deselect the function when you do not wish to have the heating on.

"cooling" means that you obtain cooling in the home in hot weather. You can deselect this function when you do not wish to have the cooling running. This alternative requires the accessory for cooling to be installed.

NOTE!

If you deselect "addition" it may mean that sufficient heating in the accommodation is not achieved.

MENU 4.3 - MY ICONS

You can select what icons should be visible when the door to F1355 is closed. You can select up to 3 icons. If you select more, the ones you selected first will disappear. The icons are displayed in the order you selected them.

MENU 4.4 - TIME & DATE



Set time and date, display mode and time zone here.

TIP!

Time and date are set automatically if the heat pump is connected to myUplink. To obtain the correct time, the time zone must be set.

MENU 4.6 - LANGUAGE

Choose the language that you want the information to be displayed in here.

MENU 4.7 - HOLIDAY SETTING

To reduce energy consumption during a holiday you can schedule a reduction in heating and hot water temperature. Cooling, ventilation, pool and solar panel cooling can also be scheduled if the functions are connected.

If a room sensor is installed and activated, the desired room temperature (°C) is set during the time period. This setting applies to all climate systems with room sensors.

If a room sensor is not activated, the desired offset of the heating curve is set. One step is usually enough to change the room temperature by one degree, but in some cases several steps may be required. This setting applies to all climate systems without room sensors.

The vacation scheduling starts at 00:00 on the start date and stops at 23:59 on the stop date.



TIP!

Stop the holiday setting about a day before your return so that room temperature and hot water have time to return to their usual levels.



TIP!

Set the vacation setting in advance and activate just before departure in order to maintain the comfort.

MENU 4.9 - ADVANCED

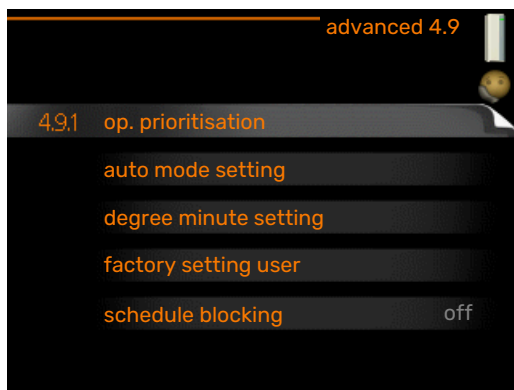

Menu **advanced** has orange text and is intended for the advanced user. This menu has several sub-menus.

MENU 4.9.1 - OP. PRIORITISATION

op. prioritisation

Setting range: 0 to 180 min

Default value: 30 min

Choose here how long the heat pump should work with each requirement if there are two or more requirements at the same time. If there is only one requirement the heat pump only works with that requirement.

The indicator marks where in the cycle the heat pump is.

If 0 minutes is selected, this means that the requirement is not prioritised, but will only be activated when there is no other requirement.

MENU 4.9.2 - AUTO MODE SETTING

start cooling (accessory required)

Setting range: -20 – 40 °C

Factory setting: 25

stop heating

Setting range: -20 – 40 °C

Default values: 17

stop additional heat

Setting range: -25 – 40 °C

Factory setting: 5

balance point

Setting range: -40 – 20 °C

Default value: -20

filtering time

Setting range: 0 – 48 h

Default value: 24 h

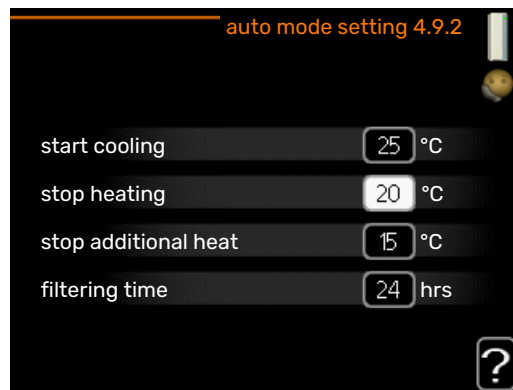

When the operating mode is set to "auto", the heat pump selects when start and stop of additional heat and heat production is permitted, dependent on the average outdoor temperature. If accessories for cooling are present or if the heat pump has the integrated cooling function, you can also select the start temperature for cooling.

Select the average outdoor temperatures in this menu.



NOTE!

It cannot be set "stop additional heat" higher than "stop heating".

balance point: The "balance point" specifies the outdoor temperature at which the installation is estimated to meet all needs, without the aid of additional heat. It is not possible to set "balance point" lower than 14°C below the set value for "stop heating".

filtering time: You can also set the time (filtering time) over which the average temperature is calculated. If you select 0, the current outdoor temperature is used.

NOTE!

In systems where heating and cooling share the same pipes "stop heating" cannot be set higher than "start cooling" if there is not a cooling/heating sensor.

MENU 4.9.3 - DEGREE MINUTE SETTING

current value

Setting range: -3000 – 3000

start compressor

Setting range: -1000 – -30

Default value: -60

step difference compressors

Setting range: 10 – 2000

Default value: 60

start diff additional heat

Setting range: 100 – 1000

Factory setting: 400

diff. between additional steps

Setting range: 0 – 1000

Factory setting: 100

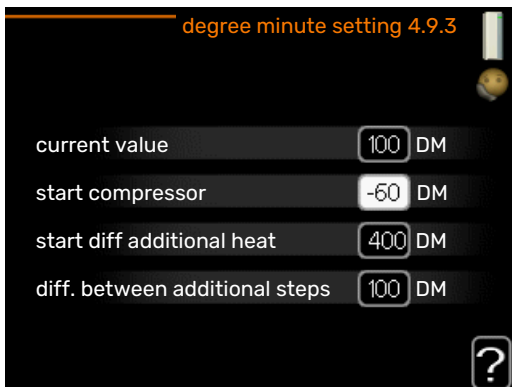

Degree minutes are a measurement of the current heating requirement in the house and determine when the compressor respectively additional heat will start/stop.

NOTE!

Higher value on "start compressor" gives more compressor starts, which increase wear on the compressor. Too low value can give uneven indoor temperatures.

MENU 4.9.4 - FACTORY SETTING USER

All settings that are available to the user (including advanced menus) can be reset to default values here.

NOTE!

After factory setting, personal settings such as heating curves must be reset.

MENU 4.9.5 - SCHEDULE BLOCKING

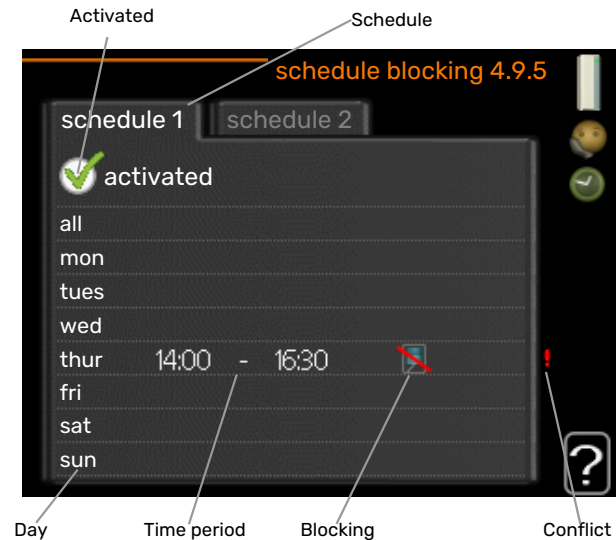

The compressor can be scheduled to be blocked for up to two different time periods here.

When scheduling is active the actual blocking symbol in the main menu on the heat pump symbol is displayed.

Schedule: The period to be changed is selected here.

Activated: Scheduling for the selected period is activated here. Set times are not affected at deactivation.

Day: Select which day or days of the week the scheduling is to apply to here. To remove the scheduling for a particular day, the time for that day must be reset by setting the start time to the same as the stop time. If the row "all" is used, all days in the period are set according to that row.

Time period: The start and stop time for the selected day for scheduling are selected here.

Blocking: The desired blocking is selected here.

Conflict: If two settings conflict with each other, a red exclamation mark is displayed.



Blocking the compressor.



Blocking additional heat.



TIP!

If you wish to set similar scheduling for every day of the week start by filling in "all" and then changing the desired days.



TIP!

Set the stop time earlier than the start time so that the period extends beyond midnight. Scheduling then stops at the set stop time the day after.

Scheduling always starts on the date that the start time is set for.



NOTE!

Long term blocking can cause reduced comfort and operating economy.

Menu 5 - SERVICE

OVERVIEW

5 - SERVICE **	5.1 - operating settings **	5.1.1 - hot water settings *
		5.1.2 - max flow line temperature
		5.1.3 - max diff flow line temp.
		5.1.4 - alarm actions
		5.1.5 - fan sp. exhaust air *
		5.1.7 - br pmp al set. **
		5.1.8 - operating mode brine pump **
		5.1.9 - brine pump speed **
		5.1.10 - op. mod heat med pump **
		5.1.11 - pump speed heating medium **
		5.1.12 - addition
		5.1.14 - flow set. climate system
		5.1.15 - adjust alarm levels
		5.1.22 - heat pump testing
		5.1.24 - blockFreq
		5.1.28 - Heating contr. compressors
	5.2 - system settings	5.2.1 - master/slave mode **
		5.2.2 - installed slaves
		5.2.3 - docking
		5.2.4 - accessories
	5.3 - accessory settings	5.3.1 - FLM *
		5.3.2 - shunt controlled add. heat *
		5.3.3 - extra climate system * 5.3.3.X - climate system 2 - 8 *
		5.3.4 - solar heating *
		5.3.6 - step controlled add. heat
		5.3.8 - hot water comfort *
		5.3.10 - shunt controlled brine *
		5.3.11 - modbus *
		5.3.21 - flow sensor / energy meter*
	5.4 - soft in/outputs **	
	5.5 - factory setting service **	
	5.6 - forced control **	
	5.7 - start guide **	
	5.8 - quick start **	
	5.9 - floor drying function	
	5.10 - change log **	
	5.12 - country	

* Accessory needed.

** This menu is also set in the slave heat pump's limited menu system.

Go to the main menu and hold the Back button in for 7 seconds to access the Service menu.

Sub-menus

Menu **SERVICE** has orange text and is intended for the advanced user. This menu has several sub-menus. Status information for the relevant menu can be found on the display to the right of the menus.

operating settings Operating settings for the heat pump.

system settings System settings for the heat pump, activating accessories etc.

accessory settings Operational settings for different accessories.

soft in/outputs Setting software-controlled inputs and outputs on terminal blocks (X5) and (X6).

factory setting service Total reset of all settings (including settings available to the user) to default values.

forced control Forced control of the different components in the heat pump.

start guide Manual start of the start guide which is run the first time the heat pump is started.

quick start Quick starting the compressor.



CAUTION!

Incorrect settings in the service menus can damage the heat pump.

MENU 5.1 - OPERATING SETTINGS

Operating settings can be made for the heat pump in the sub menus.

This menu is also set in the slave heat pump's limited menu system.

MENU 5.1.1 - HOT WATER SETTINGS



CAUTION!

The factory set tap water temperatures specified in the manual can vary due to the directives in force in different countries. From this menu, you can check the relevant settings for the system.

The hot water settings require that hot water production is activated in menu 5.2.4 - "accessories".

economy

Setting range start temp. economy: 5 – 55 °C

Factory setting start temp. economy: 38 °C

Setting range stop temp. economy: 5 – 60 °C

Factory setting stop temp. economy: 48 °C

normal

Setting range start temp. normal: 5 – 60 °C

Factory setting start temp. normal: 41 °C

Setting range stop temp. normal: 5 – 65 °C

Factory setting stop temp. normal: 50 °C

luxury

Setting range start temp. lux: 5 – 70 °C

Factory setting start temp. lux: 44 °C

Setting range stop temp. lux: 5 – 70 °C

Factory setting stop temp. lux: 53 °C

stop temp. per. increase

Setting range: 55 – 70 °C

Factory setting: 55 °C

step difference compressors

Setting range: 0.5 – 4.0 °C

Factory setting: 1.0 °C

charge method

Setting range: target temp, delta temp

Default value: delta temp

Here you set the start and stop temperature of the hot water for the different comfort options in menu 2.2 as well as the stop temperature for periodic increase in menu 2.9.1.

If several compressors are available set the difference between engagement disengagement of them during hot water charging and fixed condensing.

The charge method for hot water operation is selected here. "delta temp" is recommended for heaters with charge coil, "target temp" for double-jacketed heaters and heaters with hot water coil.

MENU 5.1.2 - MAX FLOW LINE TEMPERATURE

climate system

Setting range: 20-80 °C

Default value: 60 °C

Here, you set the maximum supply temperature for the climate system. If the installation has more than one climate system, individual maximum supply temperatures can be set for each system. Climate system 2 - 8 cannot be set to a higher max supply temperature than climate system 1.



NOTE!

For underfloor heating systems, max flow line temperature should normally be set to between 35 and 45°C.

MENU 5.1.3 - MAX DIFF FLOW LINE TEMP.

max diff compressor

Setting range: 1 – 25 °C

Default value: 10 °C

max diff addition

Setting range: 1 – 24 °C

Default value: 7 °C

min. brine out

Setting range: -5 – 5 °C

Factory setting: 0 °C

Here you set the maximum permitted difference between the calculated and actual supply temperature in the event of compressor or additional heat mode respectively. Max diff. additional heat can never exceed max diff. compressor

max diff compressor

If the current supply temperature *exceeds* the calculated supply by set value, the degree minute value is set to +2. The compressor in the heat pump stops if there is only a heating demand.

max diff addition

If "addition" is selected and activated in menu 4.2 and the current supply temperature *exceeds* the calculated temperature by the set value, the additional heat is forced to stop.

min. brine out

If there is a difference between temperature sensor, heating medium supply (BT25) and temperature sensor, condenser supply (BT12), you can set a fixed offset here to compensate for the difference.

MENU 5.1.4 - ALARM ACTIONS

Select how you want the heat pump to alert you that there is an alarm in the display here.

The different alternatives are; the heat pump stops producing hot water and/or reduces the room temperature.

Factory setting: No action selected.



NOTE!

If no alarm action is selected, it can result in higher energy consumption in the event of an alarm.

MENU 5.1.5 - FAN SP. EXHAUST AIR (ACCESSORY IS REQUIRED)

normal and speed 1-4

Setting range: 0 - 100 %

Set the speed for the five different selectable speeds for the fan here.

If several exhaust air modules are installed settings can be made for each fan.



NOTE!

An incorrectly set ventilation flow can damage the house and may also increase energy consumption.

MENU 5.1.7 - BR PMP AL SET.

min. brine out

Setting range: -12 - 15 °C

Default value: -8 °C

max brine in

Setting range: 10 - 30 °C

Default value: 30 °C

min. brine out

Set the temperature at which the heat pump is to activate the alarm for low temperature in outgoing brine.

If "automatic reset" is selected, the alarm resets when the temperature has increased by 1 °C below the set value.

The compressor in the cooling module EP14 slows down when the brine temperature reaches the set minimum value for brine temperature. Compressor control tries to maintain the brine at a temperature approx. 2 ° greater than the set value for brine out.

max brine in

Set the temperature at which the heat pump is to activate the alarm for high temperature in incoming brine.

MENU 5.1.8 - OPERATING MODE BRINE PUMP

op. mode

Setting range: intermittent, continuous, 10 days continuous

Default value: intermittent

This menu is also set in the slave heat pump's limited menu system.

continuous: Continuous operation.



TIP!

You can use "10 days continuous" at start-up to obtain continuous circulation during a start-up time in order to make it easier to bleed the system.

MENU 5.1.9 - BRINE PUMP SPEED

op. mode

Setting range: auto / manual / fixed delta

Default value: auto

delta-T, fixed delta

Setting range: 2 - 10 °C

Factory setting: 4 °C

speed in wait mode, EP14

Setting range: 1 - 100 %

Factory setting: 30 %

speed in wait mode, EP15

Setting range: 1 - 100 %

Factory setting: 30 %

Speed extern. contr. (AUX)

Setting range: 1 - 100 %

Factory setting: 100 %

manual, EP14

Setting range: 1 - 100 %

Factory setting: 100 %

manual, EP15

Setting range: 1 - 100 %

Factory setting: 100 %

speed passive cooling EP14 (accessory required)

Setting range: 1 - 100 %

Factory setting: 75 %

speed passive cooling EP15 (accessory required)

Setting range: 1 - 100 %

Factory setting: 75 %

speed active cooling EP14 (accessory required)

Setting range: 1 - 100 %

Factory setting: 75 %

speed active cooling EP15 (accessory required)

Setting range: 1 - 100 %

Factory setting: 75 %

speed in wait mode, cooling EP14 (accessory required)

Setting range: 1 - 100 %

Factory setting: 30 %

speed in wait mode, cooling EP15 (accessory required)

Setting range: 1 - 100 %

Factory setting: 30 %

temperature difference, active cooling (accessory required)

Setting range: 2 - 10 °C

Factory setting: 5 °C

Set the speed of the brine pumps for this heat pump here. Select "auto" if the speed of the brine pumps are to be regulated automatically (factory setting) for optimal operation.

For manual operation of the brine pumps, deactivate "auto" and set the value to between 0 and 100 %.

For operation of brine pumps with "fixed delta", select "fixed delta" under "op. mode" and set the value between 2 and 10 °C.

If there are accessories for cooling, you can also set the brine pump's speed during passive cooling operation here (the brine pump then runs in manual operation).

This menu is also set in the slave heat pump's limited menu system.

MENU 5.1.10 - OP. MOD HEAT MED PUMP**op. mode**

Setting range: auto, intermittent

Default value: intermittent

Set the operating mode of the brine pumps for this heat pump here.

This menu is also set in the slave heat pump's limited menu system.

auto: The heating medium pumps run according to the current operating mode for F1355.

intermittent: The heating medium pumps start 20 seconds before, and stop at the same time, as the compressor.

MENU 5.1.11 - PUMP SPEED HEATING MEDIUM**op. mode**

Setting range: auto / manual

Default value: auto

Manual setting, hot water

Setting range: 1 - 100 %

Factory setting: 70 %

Manual setting, heating

Setting range: 1 - 100 %

Default values: 70 %

Manual setting, pool

Setting range: 1 - 100 %

Default values: 70 %

speed in wait mode

Setting range: 1 - 100 %

Default values: 30 %

min. allowed speed

Setting range: 1 - 50%

Default values: 1 %

max. allowed speed

Setting range: 50 - 100 %

Default values: 100 %

speed active cooling (accessory is required)

Setting range: 1 - 100 %

Default values: 70 %

speed passive cooling (accessory is required)

Setting range: 1 - 100 %

Default values: 70 %

Set the speed at which the heat pumps are to operate in the present operating mode for this heat pump. Select "auto" if the speed of the heating medium pump is to be regulated automatically (factory setting) for optimal operation.

If "auto" is activated for heating operation, you can also make the setting "max. allowed speed" which restricts the heating medium pumps and does not allow them to run at a higher speed than the set value.

For manual operation of the heating medium pumps deactivate "auto" for the current operating mode and set the value to between 0 and 100% (the previously set value for "max. allowed speed" no longer applies).

"heating" means heating operating mode for the heating medium pumps.

"speed in wait mode" means heating or cooling operating mode for the heating medium pumps, but when the heat pump has neither a need for compressor operation nor electric additional heat and slows down.

This menu is also set in the slave heat pump's limited menu system.

"hot water" means hot water operating mode for the heating medium pumps.

"pool" means pool heating operating mode for the heating medium pumps.

"cooling" means cooling operating mode for the heating medium pumps.

If there are accessories for cooling present or if the heat pump has a built-in function for cooling you can also set the heating medium pump speed during active respectively cooling operating modes (the heating medium pump then runs in manual operation).

MENU 5.1.12 - ADDITION

Make settings for connected additional heat (step controlled or shunt controlled additional heat) here.

Select whether step controlled or shunt controlled additional heat is connected. Then you can make settings for the different alternatives.

add.type: step controlled**max step**

Setting range (binary stepping deactivated): 0 - 3

Setting range (binary stepping activated): 0 - 7

Default value: 3

fuse size

Setting range: 1 - 400 A

Factory setting: 16 A

Select this option, if the step-controlled additional heat is connected and is positioned before or after the reversing valve for hot water charging (QN10). Step-controlled additional heat could be, for example, an external electric boiler.

When binary stepping is deactivated (off), the settings refer to linear stepping.

Here you can set the maximum number of permitted additional heat steps, if there is internal additional heat in the tank (only accessible if the additional heat is positioned after QN10), whether binary stepping is to be used and the size of the fuse.

add.type: shunt controlled**prioritised additional heat**

Setting range: on/off

Factory setting: off

minimum running time

Setting range: 0 - 48 h

Default value: 12 h

min temp.

Setting range: 5 - 90 °C

Default value: 55 °C

mixing valve amplifier

Setting range: 0.1 - 10.0

Default value: 1.0

mixing valve step delay

Setting range: 10 - 300 s

Default values: 30 s

fuse size

Setting range: 1 - 400 A

Factory setting: 16 A

Select this option if shunt controlled additional heat is connected.

Set when the addition is to start, the minimum run time and the minimum temperature for external addition with shunt here. External addition with shunt is for example a wood/oil/gas/pellet boiler.

You can set shunt valve amplification and shunt valve waiting time.

Selecting "prioritised additional heat" uses the heat from the external additional heat instead of the heat pump. The shunt valve is regulated as long as heat is available, otherwise the shunt valve is closed.



TIP!

See the accessory installation instructions for function description.

MENU 5.1.14 - FLOW SET. CLIMATE SYSTEM

presettings

Setting range: radiator, floor heat., rad. + floor heat., DOT °C

Default value: radiator

Setting range DOT: -40.0 – 20.0 °C

The factory setting of DOT value depends on the country that has been given for the product's location. The example below refers to Sweden.

Factory setting DOT: -20.0 °C

own setting

Setting range dT at DOT: 0.0 – 25.0

Factory setting dT at DOT: 10.0

Setting range DOT: -40.0 – 20.0 °C

Factory setting DOT: -18.0 °C

The type of heating distribution system the heating medium pump (GP1) works towards is set here.

dT at DOT is the difference in degrees between flow and return temperatures at dimensioned outdoor temperature.

MENU 5.1.15 - ADJUST ALARM LEVELS

Adjust (BP8) breaking value, EP14

Setting range F1355-28 and 43: -16.7 °C – 10 °C

Factory setting F1355-28 and 43: -16.7 °C

Adjust (BP8) breaking value, EP15

Setting range F1355-28: -16.7 °C – 10 °C

Factory setting F1355-28: -16.7 °C

Setting range F1355-43: -18.2 °C – 10 °C

Factory setting F1355-43: -18.2 °C

Here, you adjust the breaking value for low-pressure sensor (BP8).

MENU 5.1.22 - HEAT PUMP TESTING



CAUTION!

This menu is intended for testing F1355 according to different standards.

Use of this menu for other reasons may result in your installation not functioning as intended.

This menu contains several sub-menus, one for each standard.

MENU 5.1.24 - BLOCKFREQ

blockFreq 1

Selectable setting range in the display:

start: 17 – 115 Hz

stop: 22 – 120 Hz

Maximum setting range: 50 Hz.

blockFreq 2

Selectable setting range in the display:

start: 17 – 115 Hz

stop: 22 – 120 Hz

Maximum setting range: 50 Hz.

Here you can set a frequency range where the compressor is blocked. The parameters for the setting range differ depending on which product is controlled by the setting.



CAUTION!

A large blocked frequency range can cause the compressor to run jerkily.

MENU 5.1.28 - HEATING CONTR. COMPRESSORS

Setting range: Degr. mins., Cluster

Default value: Degr. mins.

Here you set the start sequence for the compressors.

In a multi-installation, you can choose whether the start sequence is to be controlled by the factory setting for degree minutes or controlled as grouped and the heat pumps will control according to demand.

MENU 5.2 - SYSTEM SETTINGS

Make different system settings for the heat pump here, e.g. master/slave settings, docking settings and which accessories are installed.

MENU 5.2.1 - MASTER/SLAVE MODE

Setting range: master, slave 1-8

Default value: master

Set the heat pump as master- or slave unit. In systems with one heat pump it must be "master".

This menu is also set in the slave heat pump's limited menu system.

NOTE!

In systems with several heat pumps, each pump is allocated a unique ID. In other words, only one heat pump can be "master" and only one can be "slave 5".

MENU 5.2.2 - INSTALLED SLAVES

Set which slaves are connected to the master heat pump.

There are two ways of activating connected slaves. You can either mark the alternative in the list or use the automatic function "search installed slaves".

search installed slaves

Mark "search installed slaves" and press the OK button to automatically find connected slaves for the master heat pump.

MENU 5.2.3 - DOCKING

Enter how your system is docked regarding pipes, for example to pool heating, hot water heating and heating the building.

This menu has a docking memory which means that the control system remembers how a particular reversing valve is docked and automatically enters the correct docking the next time you use the same reversing valve.

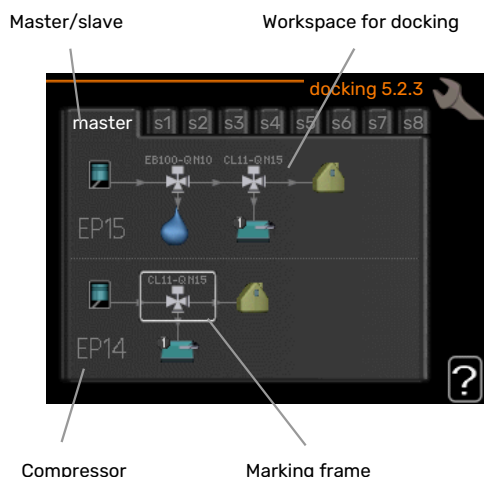

Master/slave: Select the heat pump for which the docking setting is to be made (if there is only one heat pump in the system, only master is displayed).

Compressor: Here, you select whether the compressor (EP14 or EP15) is blocked (factory setting), externally controlled via soft input or standard (docked for example to pool heating, hot water charging and heating the building).

Marking frame: Move around the marking frame using the control knob. Use the OK button to select what you want to change and to confirm the setting in the options box that appears to the right.

Workspace for docking: The system docking is drawn here.

Symbol	Description
	Compressor (blocked)
	Compressor (externally controlled)
	Compressor (standard)
	Reversing valves for hot water, cooling respectively pool control. The designations above the reversing valve indicate where it is electrically connected (EB100 = Master, EB101 = Slave 1, CL11 = Pool 1 etc.).
	Hot water charging
	Pool 1
	Pool 2
	Heating (heating the building, includes any extra climate system)
	Cooling

MENU 5.2.4 - ACCESSORIES

Inform the heat pump which accessories are installed here.

If the water heater is connected to F1355 hot water charging must be activated here.

There are two ways of activating connected accessories. You can either mark the alternative in the list or use the automatic function "search installed acc.".

search installed acc.

Mark "search installed acc." and press the OK button to automatically find connected accessories for F1355.

NOTE!

Certain accessories are not found with the search function, but must be selected instead in menu 5.4.



CAUTION!

Only mark the option for ground water pump if the accessory AXC 50 is to be used to control the circulation pump.

MENU 5.3 - ACCESSORY SETTINGS

The operating settings for accessories that are installed and activated are made in the sub-menus for this.

MENU 5.3.1 - FLM

continuous pump op.

Setting range: on/off

Factory setting: off

pump speed

Setting range: 1 - 100%

Factory setting: 100 %

time between defrosts

Setting range: 1 - 30 h

Default value: 10 h

months btwn filter alarms

Setting range: 1 - 12

Default value: 3

activate cooling

Setting range: on/off

Factory setting: off

max. fan speed

Setting range: 1 - 100%

Factory setting: 70 %

min. fan speed

Setting range: 1 - 100%

Factory setting: 60 %

contr. sensor

Setting range: 0 - 4

Factory setting: 1

time between speed changes

Setting range: 1 - 12

Factory setting: 10 min

continuous pump op.: Select for continuous operation of the circulation pump in the exhaust air module.

pump speed: Set the desired speed for the circulation pump in the exhaust air module.

time between defrosts: Here, you can set the minimum time that must pass between defrosts of the heat exchanger in the exhaust air module.

When the exhaust air module is in operation the heat exchanger is cooled so that ice builds up on it. When too much ice builds up the heat transfer capacity of the heat exchanger is reduced and defrosting is required. Defrosting warms up the heat exchanger so that the ice melts and runs off via the condensation hose.

months btwn filter alarms: Here, you can set how many months should pass before the heat pump notifies that it is time to clean the filter in the exhaust air module.

Clean the exhaust air module's air filter regularly, how often depends on the amount of dust in the ventilation air.

activate cooling: Here, you can activate cooling via the exhaust air module. When the function has been activated, the cooling settings are displayed in the menu system.



NOTE!

The following menus require the accessory HTS 40 and that "demand-contr. ventil." is activated in menu 4.1.11.

max. fan speed: Here, you set the highest permitted fan speed during demand-controlled ventilation.

min. fan speed: Here, you set the lowest permitted fan speed during demand-controlled ventilation.

contr. sensor 1 - 4: Here, you select which exhaust air module(s) will be affected by which HTS unit(s). If two or more HTS units control an exhaust air module, the ventilation is adjusted base on the units' average value.

time between speed changes: Here, you set the time it takes for the exhaust air module to increase/decrease the fan speed step-by-step until the desired relative humidity is obtained. At the factory setting, the fan speed is adjusted by one percentage point every ten minutes.



TIP!

See the accessory installation instructions for function description.

MENU 5.3.2 - SHUNT CONTROLLED ADD. HEAT

prioritised additional heat

Setting range: on/off

Factory setting: off

start diff additional heat

Setting range: 0 - 2000 DM

Default values: 400 DM

minimum running time

Setting range: 0 – 48 h

Default value: 12 h

min temp.

Setting range: 5 – 90 °C

Default value: 55 °C

mixing valve amplifier

Setting range: 0.1 – 10.0

Default value: 1.0

mixing valve step delay

Setting range: 10 – 300 s

Default values: 30 s

Set when the addition is to start, the minimum run time and the minimum temperature for external addition with shunt here. External addition with shunt is for example a wood/oil/gas/pellet boiler.

You can set shunt valve amplification and shunt valve waiting time.

Selecting "prioritised additional heat" uses the heat from the external additional heat instead of the heat pump. The shunt valve is regulated as long as heat is available, otherwise the shunt valve is closed.



TIP!

See the accessory installation instructions for function description.

MENU 5.3.3 - EXTRA CLIMATE SYSTEM

use in heating mode

Setting range: on/off

Factory setting: on

use in cooling mode

Setting range: on/off

Factory setting: off

mixing valve amplifier

Setting range: 0.1 – 10.0

Default value: 1.0

mixing valve step delay

Setting range: 10 – 300 s

Default values: 30 s

Contr. pump GP10

Setting range: on/off

Factory setting: off

Here, you select which climate system (2 - 8) you wish to set.

use in heating mode: If the heat pump is connected to a climate system(s) for cooling, any condensation can take place in this/these. Check that "use in heating mode" has been selected for the climate system(s) that is/are not adapted for cooling. This setting means that the sub-shunt for the extra climate system closes when cooling operation is activated.

use in cooling mode: Select "use in cooling mode" for climate systems that are adapted to handle cooling. For 2-pipe cooling you can select both "use in cooling mode" and "use in heating mode", while for 4-pipe cooling you can only select one option.



NOTE!

This setting option only appears if the heat pump is activated for cooling operation.

mixing valve amplifier, mixing valve step delay: Here, you set the shunt amplification and shunt waiting time for the various extra climate systems that are installed.

Contr. pump GP10: Here, you can set the speed of the circulation pump manually.

See the accessory installation instructions for function description.

MENU 5.3.4 - SOLAR HEATING

start delta-T

Setting range: 1 – 40 °C

Default value: 8 °C

stop delta-T

Setting range: 0 – 40 °C

Default value: 4 °C

max. tank temperature

Setting range: 5 – 110 °C

Default value: 95 °C

max. solar collector temp.

Setting range: 80 – 200 °C

Default value: 125 °C

anti-freeze temperature

Setting range: -20 – +20 °C

Default value: 2 °C

start solar collector cooling

Setting range: 80 – 200 °C

Default value: 110 °C

start delta-T, stop delta-T: Here, you can set the temperature difference between solar panel and solar tank at which the circulation pump will start and stop.

max. tank temperature, max. solar collector temp.: Here, you can set the maximum temperatures in the tank and solar panel respectively at which the circulation pump will stop. This is to protect against excess temperatures in the solar tank.

If the unit has an anti-freeze function and/or solar panel cooling you can activate them here. When the function has been activated, you can make settings for them.

freeze protection

anti-freeze temperature: Here, you can set the temperature in the solar panel at which the circulation pump is to start to prevent freezing.

solar panel cooling

start solar collector cooling: If the temperature in the solar panel is higher than this setting, at the same time as the temperature in the solar tank is higher than the set maximum temperature, the external function for cooling is activated.

See the accessory installation instructions for function description.

MENU 5.3.6 - STEP CONTROLLED ADD. HEAT

start diff additional heat

Setting range: 0 – 2000 DM

Default values: 400 DM

diff. between additional steps

Setting range: 0 – 1000 DM

Default values: 30 DM

max step

Setting range

(binary stepping deactivated): 0 – 3

Setting range

(binary stepping activated): 0 – 7

Default value: 3

binary stepping

Setting range: on/off

Factory setting: off

Make settings for step controlled addition here. Step controlled addition is for example an external electric boiler.

It is possible, for example, to select when the additional heat is to start, to set the maximum number of permitted steps and whether binary stepping is to be used.

When binary stepping is deactivated (off), the settings refer to linear stepping.

See the accessory installation instructions for function description.

MENU 5.3.8 - HOT WATER COMFORT

activating imm heater

Setting range: on/off

Factory setting: on

activ. imm heat in heat mode

Setting range: on/off

Factory setting: off

activating the mixing valve

Setting range: on/off

Factory setting: off

outgoing hot water

Setting range: 40 – 65 °C

Default value: 55 °C

mixing valve amplifier

Setting range: 0.1 – 10.0

Default value: 1.0

mixing valve step delay

Setting range: 10 – 300 s

Default values: 30 s

Make settings for the hot water comfort here.

See the accessory installation instructions for function description.

activating imm heater: The immersion heater is activated here, if installed in the water heater.

activ. imm heat in heat mode: Activate here whether the immersion heater in the tank (requires the above alternative to be activated) is to be permitted to charge hot water, if the compressors in the heat pump are prioritising heating.

activating the mixing valve: Activated if mixer valve is installed and it is to be controlled from F1355. When the option is active, you can set the outgoing hot water temperature, shunt amplification and shunt waiting time for the mixer valve.

outgoing hot water: Here, you can set the temperature at which the mixer valve is to restrict hot water from the water heater.

MENU 5.3.10 - SHUNT CONTROLLED BRINE

max brine in

Setting range: 0 – 30 °C

Default value: 20 °C

mixing valve amplifier

Setting range: 0.1 – 10.0

Default value: 1.0

mixing valve step delay

Setting range: 10 – 300 s

Default values: 30 s

The shunt tries to maintain a set target temperature (max brine in).

See the accessory installation instructions for function description.

MENU 5.3.11 - MODBUS

address

Factory setting: address 1

word swap

Factory setting: not activated

As from Modbus 40 version 10, the address can be set between 1 - 247. Earlier versions have a fixed address (address 1).

Here, you can select if you want to have "word swap" instead of the preset standard "big endian".

See the accessory installation instructions for function description.

MENU 5.3.21 - FLOW SENSOR / ENERGY METER

Flow sensor

set mode

Setting range: EMK150 / EMK300/310/05 / EMK500

Factory setting: EMK150

energy per pulse

Setting range: 0 - 10000 Wh

Factory setting: 1000 Wh

pulses per kWh

Setting range: 1 - 10000

Factory setting: 500

Energy meter

set mode

Setting range: energy per pulse / pulses per kWh

Default value: energy per pulse

energy per pulse

Setting range: 0 - 10000 Wh

Factory setting: 1000 Wh

pulses per kWh

Setting range: 1 - 10000

Factory setting: 500

Up to two flow sensors (EMK) / energy meters can be connected on the input board AA3, terminal block X22 and X23. Select these in menu 5.2.4 - accessories.

Flow sensor (Energy measurement kit EMK)

A flow sensor (EMK) is used to measure the amount of energy produced and supplied by the heating installation for hot water and heating in the building.

The function of the flow sensor is to measure flow and temperature differences in the charge circuit. The value is presented in the display on a compatible product.

energy per pulse: Here you set the amount of energy to which each pulse will correspond.

pulses per kWh: Here you set the number of pulses per kWh that are sent to F1355.

Energy meter (Electricity meter)

The energy meter(s) is used to send pulse signals every time a certain amount of energy has been consumed.

energy per pulse: Here you set the amount of energy to which each pulse will correspond.

pulses per kWh: Here you set the number of pulses per kWh that are sent to F1355.

MENU 5.4 - SOFT IN/OUTPUTS

Here, you specify where the external switch function has been connected to the terminal block, either to one of 5 AUX inputs or to output AA101-X9.

This menu is also set in the slave heat pump's limited menu system.

Selectable inputs on terminal block AUX 1-5 (AA3-X6:9-18) and output AA3-X7 on the input board.

MENU 5.5 - FACTORY SETTING SERVICE

All settings can be reset (including settings available to the user) to default values here.

This menu is also set in the slave heat pump's limited menu system.



NOTE!

When resetting, the start guide is displayed the next time the heat pump is restarted.

MENU 5.6 - FORCED CONTROL

You can force control the different components in the heat pump and any connected accessories here.

This menu is also set in the slave heat pump's limited menu system.



CAUTION!

Forced control is only intended to be used for troubleshooting purposes. Using the function in any other way may cause damage to the components in your climate system.

MENU 5.7 - START GUIDE

When the heat pump is started for the first time the start guide starts automatically. Start it manually here.

This menu is also set in the slave heat pump's limited menu system.

See installer manual for more information about the start guide.

MENU 5.8 - QUICK START

It is possible to start the compressor from here.

This menu is also set in the slave heat pump's limited menu system.

NOTE!

There must be a heating, cooling or hot water demand to start the compressor.

CAUTION!

Do not quick start the compressor too many times over a short period of time, as this could damage the compressor and its surrounding equipment.

MENU 5.9 - FLOOR DRYING FUNCTION

length of period 1 - 7

Setting range: 0 - 30 days

Factory setting, period 1 - 3, 5 - 7: 2 days

Factory setting, period 4: 3 days

temp. period 1 - 7

Setting range: 15 - 70 °C

Default value:

temp. period 1	20 °C
temp. period 2	30 °C
temp. period 3	40 °C
temp. period 4	45 °C
temp. period 5	40 °C
temp. period 6	30 °C
temp. period 7	20 °C

Set the function for under floor drying here.

You can set up to seven time periods with different calculated supply temperatures. If fewer than seven periods are to be used, set the remaining periods to 0 days.

Mark the active window to activate the underfloor drying function. A counter at the bottom shows the number of days the function has been active. The function counts degree minutes as during normal heating operation but for the supply temperatures that are set for the respective period.

CAUTION!

During under floor drying, the heating medium pump in 100% runs, regardless of the setting in menu 5.1.10.

TIP!

If operating mode "add. heat only" is to be used, select it in menu 4.2.

For a more even flow temperature the addition can be started earlier by setting "start for addition" in menus 4.9.2 to -80. When set under floor drying periods have stopped, reset the menus 4.2 and 4.9.2 as per previous settings.

TIP!

It is possible to save a floor drying log that shows when the concrete slab has reached the correct temperature. See section "Logging floor drying" on page 53.

MENU 5.10 - CHANGE LOG

Read off any previous changes to the control system here.

The date, time, ID no. (unique to particular setting) and the new set value are shown for every change.

This menu is also set in the slave heat pump's limited menu system.

NOTE!

The change log is saved at restart and remains unchanged after factory setting.

5.12 - COUNTRY

Select here the country in which the product was installed. This allows access to country-specific settings in your product.

Language settings can be made regardless of this selection.

NOTE!

This option locks after 24 hours, after restarting the display and during program updating.

Service

Service actions



CAUTION!

Servicing should only be carried out by persons with the necessary expertise.

When replacing components on F1355 only replacement parts from NIBE may be used.

EMERGENCY MODE



CAUTION!

The switch (SF1) must not be set to "I" or  until F1355 has been filled with water. Otherwise the compressor could be damaged.

Emergency mode is used in event of operational interference and in conjunction with service. Hot water is not produced in emergency mode.

Emergency mode is activated by setting switch (SF1) in mode "". This means that:

- The status lamp illuminates yellow.
- The display is not lit and the control computer is not connected.
- Hot water is not produced.
- The compressor and brine pump for each cooling module are off.
- Accessories are switched off.
- Internal heating medium pumps are active.
- The emergency mode relay (K1) is active.

External additional heat is active if it is connected to the emergency mode relay (K1, terminal block X4). Ensure that the heating medium circulates through the external additional heat.

F1355 28 kW

Cooling module EP14

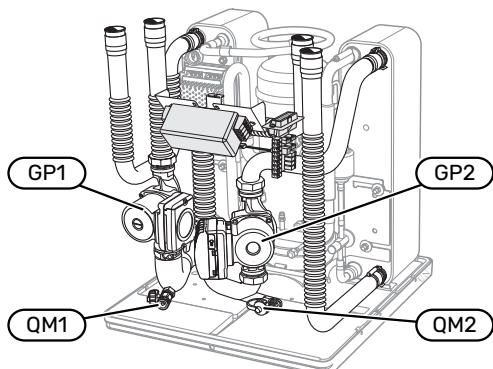

Cooling module EP15

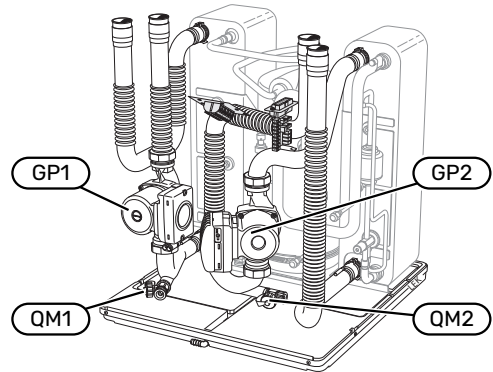

F1355 43 kW

Cooling module EP14

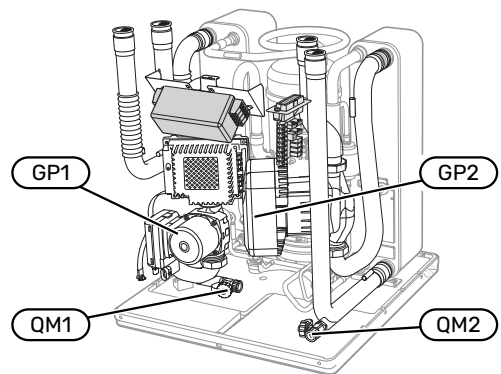

Cooling module EP15

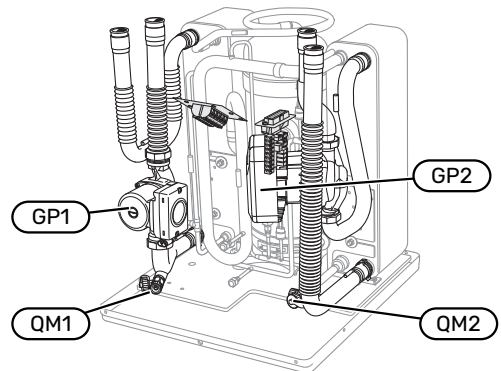

DRAINING THE WATER HEATER (IF DOCKED)

The siphon principle is used to empty the hot water heater. This can be done either via the drain valve on the incoming cold water pipe or by inserting a hose into the cold water connection.



CAUTION!

There may be some hot water, risk of scalding.

DRAINING THE CLIMATE SYSTEM

In order to carry out service on the climate system, it may be easier to drain the system first. This can be done in different ways depending on what needs doing:



CAUTION!

There may be some hot water when draining the heating medium side/climate system. There is a risk of scalding.

Draining the climate system in a cooling module

If, for example, the heating medium pump needs replacing or a cooling module needs servicing, drain the climate system as follows:

1. Close the shut-off valves outside the heat pump for the heating medium side (return and flow line).
2. Connect a hose to the draining valve (QM1) and open the valve. A small amount of liquid will run out.
3. Air must enter the system, to allow the remaining liquid to run out. To let air in, loosen the connection slightly at the shut-off valve that joins the climate system with the heat pump by connection (XL2) for the relevant cooling module.

When the climate system is empty, the required service can be carried out and/or any components can be replaced.

Draining the entire climate system

If the entire climate system requires draining, do this as follows:

1. Connect a hose to the draining valve (QM1) and open the valve. A small amount of liquid will run out.
2. Air must get into the system for the remaining liquid to run out. This is done by unscrewing the bleed screw on the highest placed radiator in the property.

When the climate system is empty, the required service can be carried out.

EMPTYING THE BRINE SYSTEM

In order to service the brine system it may be easier to drain the system first.

Draining the brine system in a cooling module

If, for example, the brine pump requires replacing or a cooling module requires servicing, drain the brine system by:

1. Close the shut-off valve outside the heat pump for the brine system.
2. Connect a hose to the draining valve (QM2), place the other opening of the hose in a vessel and open the valve. A small amount of brine will flow into the vessel.
3. Air must enter the system, to allow the remaining brine to run out. To let air in, loosen the connection slightly at the shut-off valve that joins the brine side with the heat pump by connection (XL7) for the relevant cooling module.

When the brine system is empty, the required service can be carried out.

HELPING THE CIRCULATION PUMP TO START

1. Turn off F1355 by setting the switch (SF1) to "0".
2. Remove the front cover
3. Remove the cover for the cooling module.
4. Loosen the venting screw (QM5) with a screwdriver. Hold a cloth around the screwdriver blade, because a small amount of water may run out.
5. Insert a screwdriver and turn the pump motor around.
6. Screw in the venting screw (QM5).
7. Start F1355 by setting the switch (SF1) to "I", and check that the circulation pump is working.

It is usually easier to start the circulation pump with F1355 running, and with the switch (SF1) set to "I". If the circulation pump is helped to start while F1355 is running, be prepared for the screwdriver to jerk when the pump starts.

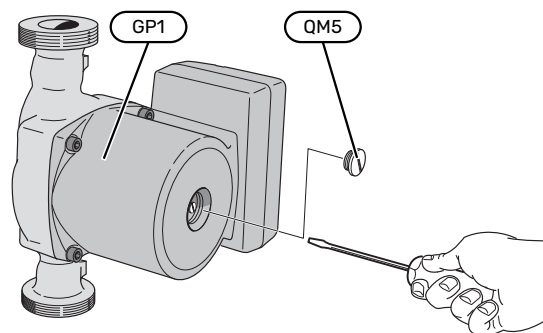

The image shows an example of what a circulation pump can look like.

TEMPERATURE SENSOR DATA

Temperature (°C)	Resistance (kOhm)	Voltage (VDC)
-10	56.20	3.047
0	33.02	2.889
10	20.02	2.673
20	12.51	2.399
30	8.045	2.083
40	5.306	1.752
50	3.583	1.426
60	2.467	1.136
70	1.739	0.891
80	1.246	0.691

EXTRACTING THE COOLING MODULES

The cooling modules can be pulled out for service and transport.



CAUTION!

The heat pump must not be moved when only the lower cooling module has been pulled out. If the heat pump is not secured in position the upper cooling module must always be removed before the lower one can be pulled out.



NOTE!

The cooling modules are easier to remove if drained first (see page 47).

Weight of the cooling module

Type (F1355)	EP14	EP15
28 kW	125 kg	130 kg
43 kW	126 kg	144 kg



CAUTION!

Switch off F1355 and turn off the current at the safety breaker.



NOTE!

Remove the front cover according to the description in the installer manual.

1. Close the shut-off valves outside the heat pump.
Drain the cooling module(s) according to the instructions on page 47.
2. Remove the side panel to be able to remove the display unit (this procedure need only be done if you are going to pull out the upper cooling module).

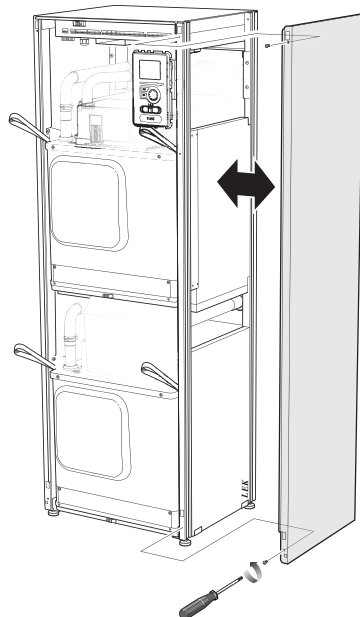

3. Disconnect the connectors for the relevant cooling module.

Cooling module EP15 (upper)

- XF2 (J)
- XF6 (E)
- XF7 (K)¹
- XF8 (L)
- XF9 (M)
- EP15-AA100:XF1 (N)

¹ Only needs to be removed at 28 kW.

Cooling module EP14 (lower)

- XF1 (A)
- XF3 (B)
- XF4 (C)
- XF5 (D)
- XF10 (F)
- XF11 (G)
- EP14-AA100:XF1 (I)

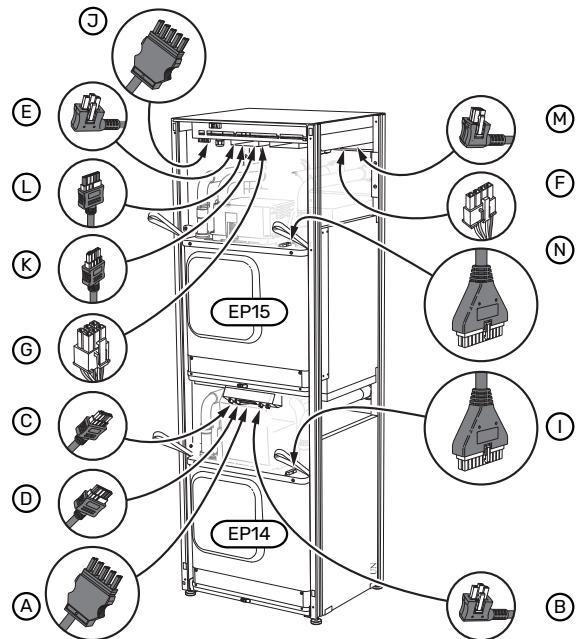

4. Remove the screws (two for each cooling module).

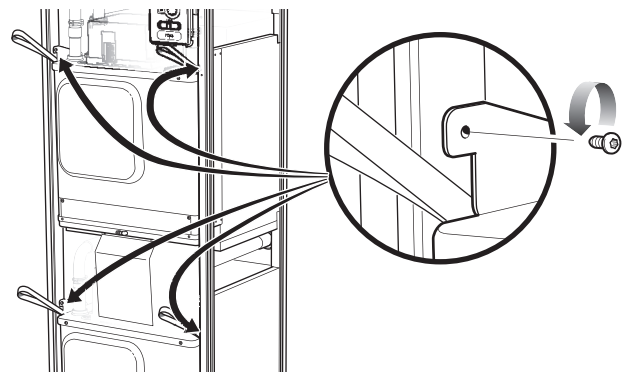

5. Pull off the clips (four for each cooling module) and separate the pipes carefully.

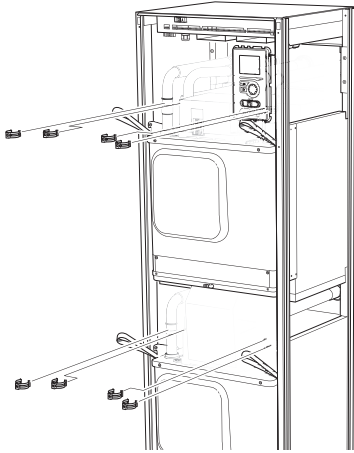

8. Carefully pull out the upper cooling module (EP15) using the module's lifting eyes.

Use a height adjustable relief surface for this procedure.

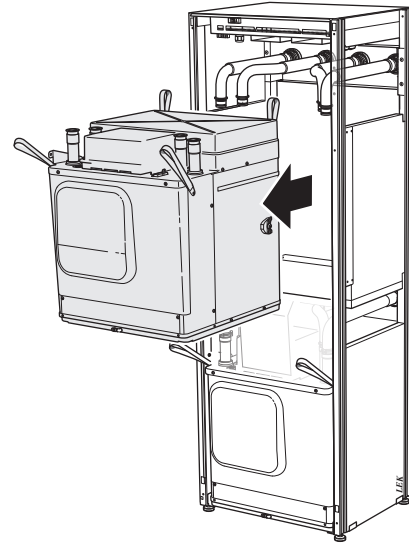

6. Remove the connector from the underside of the display unit (this procedure need only be done if you are going to pull out the upper cooling module).

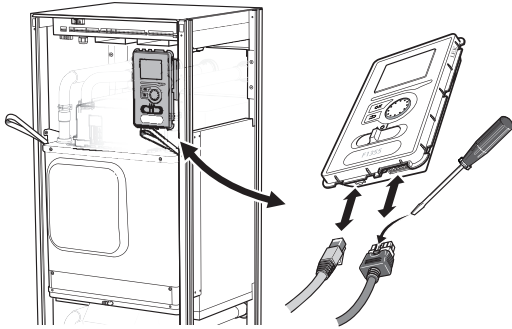

7. Remove the two screws holding the display unit in the frame (this procedure only needs to be done if you are going to pull out the upper cooling module).

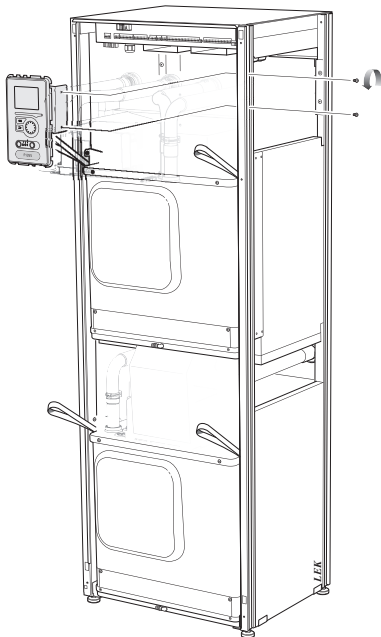

Unscrew the panel in front of the transformer and the terminal block under the panel (you only need to perform this procedure if you are going to pull out the lower cooling module).

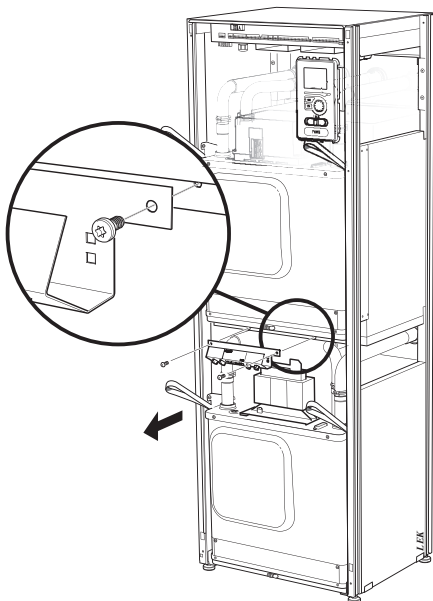
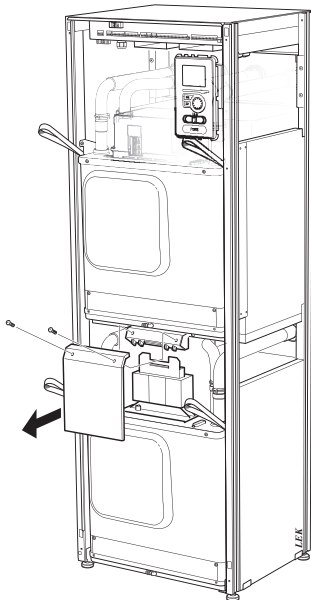

- Carefully pull out the lower cooling module (EP14) using the module's lifting eyes.

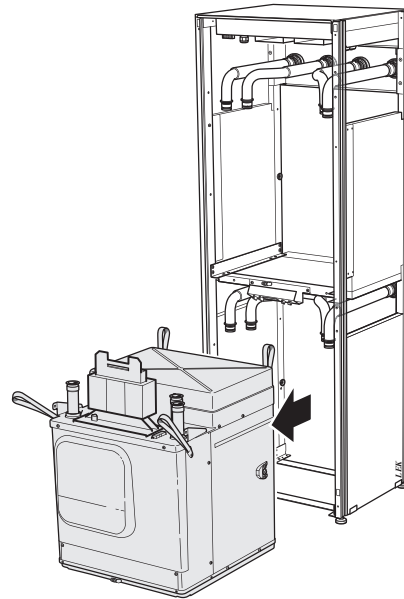

If the heat pump is not secured in position the upper cooling module must always be removed before the lower one can be pulled out.



TIP!

The cooling module is installed in reverse order.



CAUTION!

At reinstallation, new O-rings must replace the existing ones at the connections to the heat pump (see image).

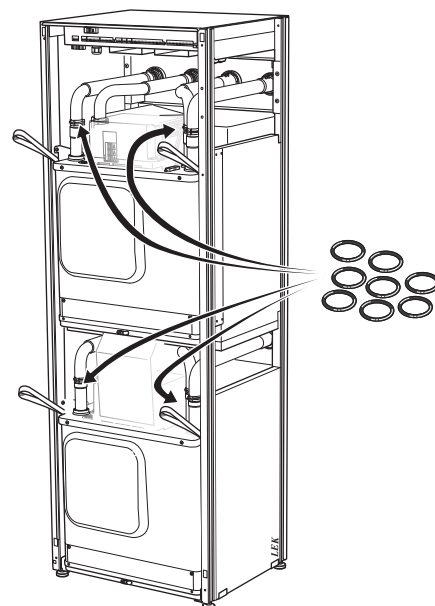

USB SERVICE OUTLET

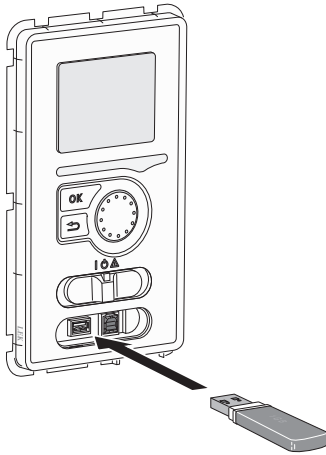

The display unit is equipped with a USB socket that can be used to update the software and save logged information in F1355.

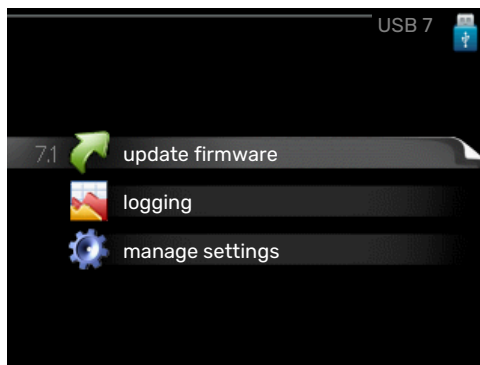
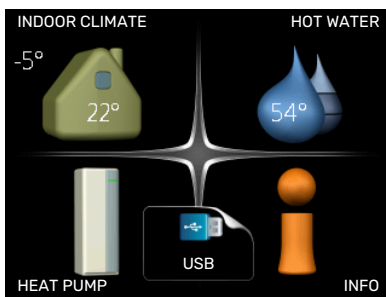

When a USB memory is connected, a new menu (menu 7) appears in the display.

Menu 7.1 - "update firmware"

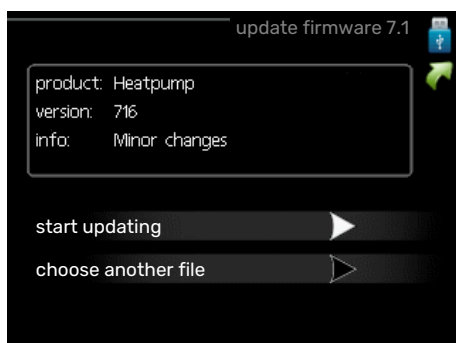

Here, you can update the software in F1355.



CAUTION!

For the following functions to work the USB memory must contain files with software for F1355 from NIBE.

The fact box at the top of the display shows information (always in English) of the most probable update that the update software has selected from the USB memory.

This information states the product for which the software is intended, the software version and general information about it. If you want a file other than the one selected, the correct file can be selected through "choose another file".

start updating

Select "start updating" if you want to start the update. You are asked whether you really want to update the software. Respond "yes" to continue or "no" to undo.

If you responded "yes" to the previous question the update starts and you can now follow the progress of the update on the display. When the update is complete F1355 restarts.



TIP!

A software update does not reset the menu settings in F1355.



NOTE!

If the update is interrupted before it is complete (for example, by a power cut), the software can be reset to the previous version if the OK button is held in during start-up until the green lamp comes on (takes about 10 seconds).

choose another file

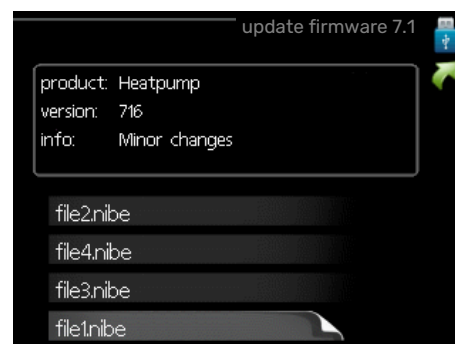

Select "choose another file" if you do not want to use the suggested software. When you scroll through the files, information about the marked software is shown in a fact box just as before. When you have selected a file with the OK button you will return to the previous page (menu 7.1) where you can choose to start the update.

Menu 7.2 - logging

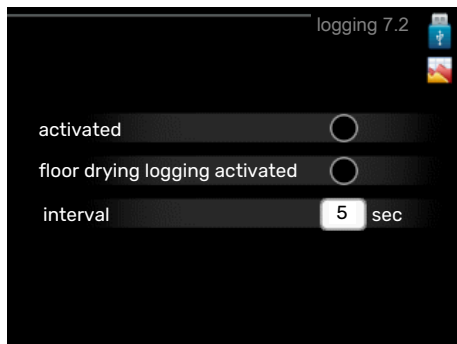

Setting range: 1 s – 60 min
Factory setting range: 5 s

Here you can choose how current measurement values from F1355 should be saved onto a log file on the USB memory.

1. Set the desired interval between loggings.
2. Tick "activated".
3. The present values from F1355 are saved in a file in the USB memory at the set interval until "activated" is unticked.



NOTE!

Untick "activated" before removing the USB memory.

Logging floor drying

Here you can save a floor drying log on the USB memory and in this way see when the concrete slab reached the correct temperature.

- Make sure that "floor drying function" is activated in menu 5.9.
- Select "logging floor drying activated".
- A log file is now created, where the temperature and the immersion heater output can be read off. Logging continues until "logging floor drying activated" is deselected or until "floor drying function" is stopped.



NOTE!

Deselect "logging floor drying activated" before you remove the USB memory.

Menu 7.3 - manage settings

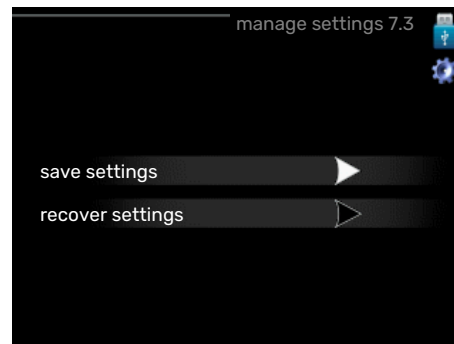

save settings

Setting option: on/off

recover settings

Setting option: on/off

In this menu, you save/upload menu settings to/from a USB memory stick.

save settings: Here, you save menu settings in order to restore them later or to copy the settings to another F1355.



NOTE!

When you save menu settings to the USB memory, you replace any previously saved settings on the USB memory.

recover settings: Here, you upload all menu settings from the USB memory stick.



NOTE!

Resetting of menu settings from the USB memory cannot be undone.

Disturbances in comfort

In most cases, F1355 notes a malfunction (a malfunction can lead to disruption in comfort) and indicates this with alarms, and instructions for action, in the display.

Info-menu

All the heat pump's measurement values are gathered under menu 3.1 in the heat pump's menu system. Examining the values in this menu can often make it easier to identify the source of the fault. See the help menu for more information about menu 3.1.

Manage alarm

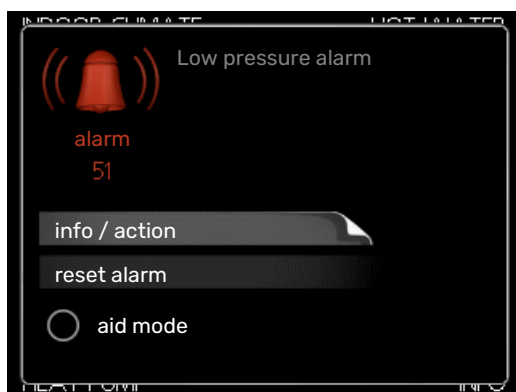

In the event of an alarm, some kind of malfunction has occurred, which is indicated by the status lamp changing from green continuously to red continuously. In addition, an alarm bell appears in the information window.

ALARM

In the event of an alarm with a red status lamp, a malfunction has occurred that the heat pump cannot remedy itself. By turning the control knob and pressing the OK button, you can see in the display what type of alarm it is and reset it. You can also choose to set the heat pump to aid mode.

info / action Here you can read what the alarm means and receive tips on what you can do to correct the problem that caused the alarm.

reset alarm In many cases, it is sufficient to select "reset alarm" for the product to revert to normal operation. If a green light comes on after selecting "reset alarm", the alarm has been remedied. If the red light is still on, and a menu called "alarm" is visible in the display, the problem causing the alarm still remains.

aid mode "aid mode" is a type of emergency mode. This means that the heat pump produces heat and/or hot water even though there is some kind of problem. This could mean that the heat pump's compressor is not running. In this case, the immersion heater produces heat and/or hot water.



NOTE!

To select aid mode an alarm action must be selected in the menu 5.1.4.



NOTE!

Selecting "aid mode" is not the same as correcting the problem that caused the alarm. The status lamp will therefore continue to be red.

If the alarm does not reset, contact your installer for suitable remedial action.

You need the product's (14 digit) serial number for servicing and support.

See section "Serial number".

Troubleshooting



CAUTION!

Work behind covers secured by screws may only be carried out by, or under the supervision of, a qualified installation engineer.



CAUTION!

In the event of action to rectify malfunctions that require work within screwed hatches, the incoming supply electricity must be isolated at the safety switch.



CAUTION!

Because F1355 can be connected to a large number of external units, these should also be checked.

BASIC ACTIONS

Start by checking the following items:

- The switch's (SF1) position.
- Group and main fuses of the building.
- The building's earth circuit breaker.
- Heat pump's earth-fault breaker.
- Miniature circuit-breaker for F1355 (FC1).
- Correctly set load monitor.

LOW HOT WATER TEMPERATURE OR NO HOT WATER

- Closed or throttled externally mounted filling valve for the hot water.
 - Open the valve.

- Mixing valve (if there is one installed) set too low.
 - Adjust the mixer valve.
- Large hot water consumption.
 - Wait until the hot water has heated up. Temporarily increased hot water capacity (temporary lux) can be activated in menu 2.1.
- Too low hot water setting.
 - Enter menu 2.2 - "comfort mode" and select a higher comfort mode.
- Too low or no operating prioritisation of hot water.
 - Enter menu 4.9.1 and increase the time for when hot water is to be prioritised. Note that if the time for hot water is increased, the time for heating production is reduced, which can give lower/uneven room temperatures.
- F1355 in incorrect operating mode.
 - Enter menu 4.2. If mode "auto" is selected, select a higher value on "stop additional heat" in menu 4.9.2.
 - If mode "manual" is selected, select "addition".
- "Holiday mode" activated in menu 4.7.
 - Enter menu 4.7 and select "Off".

LOW ROOM TEMPERATURE

- Closed thermostats in several rooms.
 - Set the thermostats to max, in as many rooms as possible. Adjust the room temperature via menu 1.1, instead of choking the thermostats.
- Too low set value on the automatic heating control.
 - Enter menu 1.1 - "temperature" and adjust the offset heating curve up. If the room temperature is only low in cold weather, the curve slope in menu 1.9.1 - "heating curve" may need to be adjusted upwards.
- Too low or no operating prioritisation of heat.
 - Enter menu 4.9.1 and increase the time for when heating is to be prioritised. Note that if the time for heating is increased the time for hot water production is reduced, which can give smaller amounts of hot water.
- F1355 in incorrect operating mode.
 - Enter menu 4.2. If mode "auto" is selected, select a higher value on "stop heating" in menu 4.9.2.
 - If mode "manual" is selected, select "heating". If this is not enough, select "addition".
- "Holiday mode" activated in menu 4.7.
 - Enter menu 4.7 and select "Off".
- External switch for changing room temperature activated.
 - Check any external switches.
- Air in the climate system.
 - Vent the climate system.

- Closed valves to the climate system.
 - Open the valves.

HIGH ROOM TEMPERATURE

- Too high set value on the automatic heating control.
 - Enter menu 1.1 - "temperature" and reduce the offset heating curve. If the room temperature is only high in cold weather, the curve slope in menu 1.9.1 - "heating curve" may need to be adjusted downwards.
- External switch for changing room temperature activated.
 - Check any external switches.

UNEVEN ROOM TEMPERATURE.

- Incorrectly set heating curve.
 - Fine-tune the heating curve in menu 1.9.1
- Too high set value on "dT at DOT"..
 - Enter menu 5.1.14 - "flow set. climate system" and reduce the value of "dT at DOT".
- Uneven flow over the radiators.
 - Adjust the flow distribution over the radiators.

LOW SYSTEM PRESSURE

- Not enough water in the climate system.
 - Fill the climate system with water and check for leaks. In event of repeated filling, contact the installer.

COMPRESSOR DOES NOT START

- There is no heating or hot water demand, nor cooling demand (accessory is required for cooling).
 - F1355 does not call on heating, hot water or cooling.
- The heat pump defrosts.
 - The compressor starts, when defrosting is complete.
- Compressor blocked due to the temperature conditions.
 - Wait until the temperature is within the product's working range.
- Minimum time between compressor starts has not been reached.
 - Wait for at least 30 minutes and then check if the compressor has started.
- Alarm tripped.
 - Follow the display instructions.
- "add. heat only" is selected.
 - Switch to "auto" or "manual" in menu 4.2 - "op. mode".

WHINING NOISE IN THE RADIATORS

- Closed thermostats in the rooms and incorrectly set heating curve.

- Set the thermostats to max. in as many rooms as possible. Adjust the heating curve via menu 1.1, instead of choking the thermostats.
- Circulation pump speed set too high.
 - Enter menu 5.1.11 (pump speed heating medium) and reduce the speed of the circulation pump.
- Uneven flow over the radiators.
 - Adjust the flow distribution between the radiators.

Alarm list

ALARM

Indication that one or more alarms are active

- Red lamp under the display lights up.
- Alarm icon is shown in the display.
- Alarm relay is activated if AUX output is selected for this.
- Comfort reduction according to selection in menu 5.1.4.

If there are several alarms, they are displayed one at a time in numerical order. Scroll between the alarms using the OK button.

Resetting the alarm

- Alarm number 1 – 39 resets automatically when the sensor has functioned for 60 seconds or after manual resetting in the menu.
- Alarm 54, manual resetting of the motor protection breaker and manual resetting in the menu.
- Alarm 70 – 99 resets automatically when the communication is established.
- Alarms 236 – 244, 253, 258 – 259 are reset automatically when the sensor has functioned for 60 seconds or after manual resetting in the menu.
- Alarm 255 is automatically reset when the input closes again.
- Other alarms are reset manually in the menu.

Restarting F1355

In many cases, alarms can be rectified by completely restarting the heat pump.

1. Switch off F1355 using the switch on the display.
2. Cut the power supply to F1355 using e.g. the main switch.
3. Leave F1355 disconnected for three minutes before restoring the power.
4. Start F1355 using the switch on the display.



CAUTION!

The alarm texts in the display vary depending on how many heat pumps are connected to the system.

Example: sensor fault -EB1yy _EPxx _BT3, where "yy" is heat pump number and "xx" is cooling module.



CAUTION!

Actions that require work behind the front cover on F1355 must always be performed by a person with the requisite expertise. If necessary, contact a service technician/installer.

Alarm no.	Alarm text on the display	Cause	Heat pump action.	May be due to/check
1	Sensor flt:BT1	No contact with the sensor (temperature sensor, outdoor).	Calculated supply temp is set to min supply.	<ul style="list-style-type: none"> • Open-circuit or short-circuit on sensor input. • Defective sensor
3	Sensor flt:BT3	No contact with the sensor (temperature sensor, heating medium return).	Compressor blocked during hot water charging. "Max condenser supply" is set to "max return".	<ul style="list-style-type: none"> • Open-circuit or short-circuit on sensor input. • Defective sensor
6	Sensor flt:BT6	No contact with the sensor (temperature sensor, hot water charging).	Hot water charging is blocked.	<ul style="list-style-type: none"> • Open-circuit or short-circuit on sensor input. • Defective sensor
11	Sens flt:BT11	No contact with the sensor (temperature sensor, brine out).	Compressor blocked.	<ul style="list-style-type: none"> • Open-circuit or short-circuit on sensor input. • Defective sensor
12	Sens flt:BT12	No contact with the sensor (temperature sensor, condenser supply).	Compressor blocked.	<ul style="list-style-type: none"> • Open-circuit or short-circuit on sensor input. • Defective sensor
14	Sensor fault: BT14 hot gas sensor	No contact with the sensor (temperature sensor, discharge).	Compressor blocked.	<ul style="list-style-type: none"> • Open-circuit or short-circuit on sensor input. • Defective sensor
23	Sens fault: AZ2-BT23 outdoor air sensor	No contact with the sensor (temperature sensor, supply air).	<ul style="list-style-type: none"> • Compressor blocked. • Stops all fans, opens QN40. 	<ul style="list-style-type: none"> • Open-circuit or short-circuit on sensor input. • Defective sensor
25	Err: BT25	No contact with the sensor (temperature sensor, heating medium supply, external).	<ul style="list-style-type: none"> • Additional heat is blocked. • New current value = BT71 + 10K 	<ul style="list-style-type: none"> • Open-circuit or short-circuit on sensor input. • Defective sensor
27	Sensor flt:BP8	No contact with the sensor (sensor, low pressure).	Compressor blocked.	<ul style="list-style-type: none"> • Open-circuit or short-circuit on sensor input. • Defective sensor

Alarm no.	Alarm text on the display	Cause	Heat pump action.	May be due to/check
28	Sens fit:BT71	No contact with the sensor (temperature sensor, heating medium return, external).	No action. Together with alarm 25, heating is blocked.	<ul style="list-style-type: none"> Open-circuit or short-circuit on sensor input. Defective sensor
29	Sens fit:BT29	No contact with the sensor (temperature sensor, compressor).	Compressor blocked.	<ul style="list-style-type: none"> Open-circuit or short-circuit on sensor input. Defective sensor
33	Fit: BT53	No contact with the sensor (temperature sensor, solar panel).	Solar accessory is blocked.	<ul style="list-style-type: none"> Open-circuit or short-circuit on sensor input. Defective sensor
34	Fit: BT54	No contact with the sensor (temperature sensor, solar coil).	Solar accessory is blocked.	<ul style="list-style-type: none"> Open-circuit or short-circuit on sensor input. Defective sensor
35	Fit: BT52	No contact with the sensor (temperature sensor, boiler).	Shunt closes. Burner stops.	<ul style="list-style-type: none"> Open-circuit or short-circuit on sensor input. Defective sensor
36	Fit: EP21 BT2	No contact with the sensor (temperature sensor, heating medium supply, climate system 2).	Control on return line sensor (EP21-BT3).	<ul style="list-style-type: none"> Open-circuit or short-circuit on sensor input. Defective sensor
37	Fit: EP22 BT2	No contact with the sensor (temperature sensor, heating medium supply, climate system 3).	Control on return line sensor (EP22-BT3).	<ul style="list-style-type: none"> Open-circuit or short-circuit on sensor input. Defective sensor
38	Fit: EP23 BT2	No contact with the sensor (temperature sensor, heating medium supply, climate system 4).	Control on return line sensor (EP23-BT3).	<ul style="list-style-type: none"> Open-circuit or short-circuit on sensor input. Defective sensor
39	Err: EQ1-BT64	No contact with the sensor (temperature sensor, cooling supply line).	Cooling blocked. Cooling shunt closes.	<ul style="list-style-type: none"> Open-circuit or short-circuit on sensor input. Defective sensor
40-42	Compr.phs 1-3	The compressor phase mentioned has been below 160 V for 30 min.	Compressor blocked.	Phase failure.
43	In phs seq	The phases are connected in the wrong order.	Compressor blocked.	The phase order of the incoming electrical supply is wrong.
44	Overheating soft-start	Fuses on the soft-start board are defective (applies to 43 kW).	Compressor blocked.	<ul style="list-style-type: none"> Defective fuse. Defective soft start card.
45	Phase fault (incorrect phase sequence or missing phase).	Communication with the soft-start board has been missing continuously for 30 minutes.	Compressor blocked.	Incorrect phase sequence or missing phase.
51	LP alarm	Low pressure sensor transmitter is below cut-out value.	Compressor blocked.	<p>Insufficient circulation of the brine.</p> <ul style="list-style-type: none"> Check the brine pump. Check that the brine has been vented. Check the brine's freezing point. <p>Lack of heating medium or other fault in the cooling circuit.</p> <ul style="list-style-type: none"> Contact an authorised refrigeration technician.
52	Temperature limiter alarm	The temperature limiter has deployed and been "open" for longer than 30 seconds.	None (managed via hardware).	<p>Insufficient flow.</p> <ul style="list-style-type: none"> Check the circulation pump. Check that the heating medium has been vented. Check the pressure in the heating medium system.
53	Lvl sen Br	Brine level switch/ pressure switch has tripped.	Compressor and brine pump blocked.	Leakage in the brine circuit.
54	MP alarm	The motor protection breaker has tripped.	Compressor blocked.	<ul style="list-style-type: none"> Phase failure. Defective compressor.
55	Hot gas alarm	The compressor has been stopped 3 times in 240 minutes because the hot gas has exceeded 135 °C.	Compressor blocked.	Defective compressor.
56	Erroneous serial no	The heat pump has a serial number that does not exist.	Compressors are stopped and relay is deactivated.	Incorrectly entered serial number.
57	Erroneous software	The heat pump software and serial numbers do not match each other.	Compressors are stopped and relay is deactivated.	Incorrect software installed.
58	Pressure switch alarm	The high or low pressure switch has tripped.	Compressor blocked.	Insufficient circulation in the brine or heating medium side.

Alarm no.	Alarm text on the display	Cause	Heat pump action.	May be due to/check
60	Lo Bri out	The temperature of the outgoing brine (BT11) goes below the set min. temperature and the alarm is selected to be continuous.	Compressor blocked.	Insufficient circulation of the brine. <ul style="list-style-type: none"> • Check the brine pump. • Check that the brine has been vented. • Check the brine's freezing point.
70	Communication fault with PCA Input.	Communication with the input board (AA3) is missing.	Blocking the relevant compressor. If the heat pump is the master, the calculated supply is set to min. supply.	Defective communication cables.
71	Com.ft Base	Communication with the input board (AA2 or AA26) is missing.	Compressor blocked.	Defective communication cables.
72	Comm.ft MC	Communication with the soft-start board (AA10) is missing.	Compressor blocked.	Defective communication cables.
73-94	Com.ft acc	Communication with the accessory card is missing.	Accessory is blocked.	<ul style="list-style-type: none"> • Defective communication cables. • The accessory is activated in the display while not connected with the communication cable. • Incorrectly connected communication cable. • Incorrectly set dipswitch. • No electrical supply to the accessory card.
96-99	Com.err. RMU	Communication with the room unit is missing.	Room unit is blocked.	Defective communication cables.
100	Communication fault with inverter	Communication with the inverter is missing.	Compressor blocked.	Check communication cables.
130-133	Perm. com. error to climate system 5-8	Communication with the accessory board has been missing for 15 seconds.	Accessory is blocked.	Selected accessory not installed.
146-149	ERS level mon	The ERS accessory is blocked by the level monitor.	Accessory is blocked.	Check condensate drain pan/drain and water trap.
193	Communication fault with EME20	There has been no communication with EME 20 three times in succession.	Accessory is blocked.	Check communication cables.
206	Perm. com. error "HW comfort"	Communication with the room unit has been missing for 15 seconds.	Accessory is blocked.	<ul style="list-style-type: none"> • Defective communication cables. • Incorrectly set dipswitch.
245 - 251	Perm. com. error "accessory"	Communication with the accessory board has been missing for 15 seconds.	Accessory is blocked.	<ul style="list-style-type: none"> • Defective communication cables. • Incorrectly set dipswitch.
252	Slave heat pump com. error.1-8	Communication with the slave is missing.	Compressor blocked in the slave.	Defective communication cables.
253	Fit: QZ1-BT70	No contact with the sensor (temperature sensor, hot water, supply line).	The mixing valve is closed and only cold water is permitted.	<ul style="list-style-type: none"> • Open-circuit or short-circuit on sensor input. • Defective sensor
257	Perm. com. error "ACS45"	Communication with the accessory board has been missing for 15 seconds.	Accessory is blocked.	<ul style="list-style-type: none"> • Defective communication cables. • Incorrectly set dipswitch.
258	Sensor fault EQ1 - BT57	Contact with the sensor has been missing for longer than 60 seconds (temperature sensor cooling, brine).	Relevant compressor blocked.	<ul style="list-style-type: none"> • Open-circuit or short-circuit on sensor input. • Defective sensor
259	Sensor fault EQ1 - BT75	Contact with the sensor has been missing for longer than 60 seconds (temperature sensor cooling, supply line heating dump).	Controls on BT50.	<ul style="list-style-type: none"> • Open-circuit or short-circuit on sensor input. • Defective sensor
292	Sen fit: BT74	No contact with the sensor (temperature sensor, cooling/heat sensor).	No action.	Check the sensor and its connections.
297	Com.ft acc	Communication fault with the accessory board.	Accessory is blocked.	<ul style="list-style-type: none"> • Defective communication cables. • Incorrectly set DIP switch.
301 - 308	Perm. com. error "Slave" 1-8	Communication with the slave has been missing for 15 seconds.	Slave compressor blocked.	Defective communication cables.
323	Sen fit: EQ1-BT25	No contact with the sensor (temperature sensor, external supply line cooling).	Cooling degree minutes are set to 0.	Check the sensor and its connections.

Alarm no.	Alarm text on the display	Cause	Heat pump action.	May be due to/check
324	Perm. com. error BM1	Communication with BM1 has been missing for 15 seconds.	Set min. calculated cooling supply to 18 °C	Defective communication cables.
336-339	Sensor fault EPXX-BT2	The input for the sensor receives unreasonably high or low value for longer than 2 seconds.	The sensor signal is replaced by EPXX-BT3-10K during shunt control.	<ul style="list-style-type: none"> • Open-circuit or short-circuit on sensor input. • Defective sensor
372	Perm. com. error pool 2	Communication with Pool 2 has been missing for 15 seconds.	Accessory is blocked.	Defective communication cables.
421	Communication fault with inverter	A communication alarm has occurred 3 times within 2 h or has been active continuously for 1 h.	Compressor blocked.	Main and group fuses and their cable connections.
423	Inverter alarm type II	An alarm on the inverter's external input has occurred 3 times within 2 h or has been active continuously for 1 h.	Compressor blocked.	Main and group fuses and their cable connections.
427	Safety stop, inverter	Failed synchronisation has occurred 3 times within 2 h or continuously for 1 h.	Compressor blocked.	Main and group fuses and their cable connections. <ul style="list-style-type: none"> • Perform a complete restart of the heat pump. See page 57.
429	Safety stop, inverter	Failed synchronisation has occurred 3 times within 2 h or continuously for 1 h.	Compressor blocked.	Main and group fuses and their cable connections.
431	Inverter alarm type I	Continuous overvoltage has been registered by the inverter for 1 h.	Compressor blocked.	Main and group fuses and their cable connections.
433	Inverter alarm type I	Continuous under-voltage has been registered by the inverter for 1 h.	Compressor blocked.	Main and group fuses and their cable connections.
435	Inverter alarm type I	A compressor phase to the inverter has been missing for 1 h.	Compressor blocked.	Main and group fuses and their cable connections.
437	Mains disturbance	Mains disturbance has occurred 3 times within 2 h or continuously for 1 h.	Compressor blocked.	Main and group fuses and their cable connections. <ul style="list-style-type: none"> • Perform a complete restart of the heat pump. See page 57.
439	Safety temp. inv. achieved	The inverter has reached max. working temperature due to inadequate cooling 3 times within 2 h or continuously for 1 h.	Compressor blocked.	<ul style="list-style-type: none"> • Insufficient circulation in the heating medium circuit. <ul style="list-style-type: none"> - Bleed heat pump and climate system. - Check that the particle filter is not blocked. - Open any radiator/underfloor heating thermostats. • Mounting inverter.
441	Inverter alarm type II	Max current in has been temporarily too high 3 times within 2 h or continuously for 1 h.	Compressor blocked.	Main and group fuses and their cable connections.
443	Safety temp. inv. achieved	The inverter has temporarily reached max. working temperature due to inadequate cooling 3 times within 2 h or continuously for 1 h.	Compressor blocked.	<ul style="list-style-type: none"> • Insufficient circulation in the heating medium circuit. <ul style="list-style-type: none"> - Bleed heat pump and climate system. - Check that the particle filter is not blocked. - Open any radiator/underfloor heating thermostats. • Mounting inverter.
445	Inverter protection	A temporary inverter fault has occurred 3 times within 2 h or continuously for 1 h.	Compressor blocked.	Main and group fuses and their cable connections. <ul style="list-style-type: none"> • Perform a complete restart of the heat pump. See page 57.
447	Phase failure	One phase has been missing 3 times within 2 h or continuously for 1 h.	Compressor blocked.	<ul style="list-style-type: none"> • Main and group fuses and their cable connections. • Compressor wiring for inverter.
449	Failed compressor starts	The compressor has run temporarily at a lower speed than the minimum permitted 3 times within 2 h or continuously for 1 h.	Compressor blocked.	<ul style="list-style-type: none"> • Main and group fuses and their cable connections. • Compressor wiring. • Compressor.
453	High current load, compressor	The output current to the compressor has been temporarily too high 3 times within 2 h or continuously for 1 h.	Compressor blocked.	<ul style="list-style-type: none"> • Main and group fuses and their cable connections. • Compressor wiring. • Inverter. • Compressor.

Alarm no.	Alarm text on the display	Cause	Heat pump action.	May be due to/check
455	High power load, compressor	The power load to the compressor has been too high 3 times within 2 h or continuously for 1 h.	Compressor blocked.	<ul style="list-style-type: none"> • Main and group fuses and their cable connections. • Compressor wiring. • Inverter. • Compressor.
483	inv. overheated	The inverter has been limited by temperature protection for an extended period.	Compressor blocked.	<p>Insufficient circulation in the heating medium circuit.</p> <ul style="list-style-type: none"> • Bleed heat pump and climate system. • Check that the particle filter is not blocked. • Open any radiator/underfloor heating thermostats. <p>Mounting inverter.</p>
504	The inverter has a message.	The inverter in NIBE PV has an error message.	No action.	<ul style="list-style-type: none"> • Check the inverter's error message in menu 3.1 - service info. • Check the inverter for NIBE PV.
505	Inverter has earth fault.	The inverter in NIBE PV has an earth fault.	No action.	Check the connection of the PV panels/inverter.
506	Mains voltage outside inv. work. range	The mains supply has been outside the inverter's working range for an extended period.	No action.	Check fuses and mains voltage to the inverter.
510	The inverter has high DC voltage.	The inverter has high DC voltage.	No action.	Check the inverter for NIBE PV.
511	Inverter com.	There has been no communication with the inverter for five days.	No action.	Check the communication cable and its connections to the inverter.
524	Com. flt accessory HTS 2	There is no communication with accessory HTS 2.	If HTS 2 is selected as the controlling accessory for cooling, the calculated supply temperature is set to 18°C.	Check the sensor and its connections.
525	Com. flt accessory HTS 3	There is no communication with accessory HTS 3.	If HTS 3 is selected as the controlling accessory for cooling, the calculated supply temperature is set to 18°C.	Check the sensor and its connections.
526	Com. flt accessory HTS 4	There is no communication with accessory HTS 4.	If HTS 4 is selected as the controlling accessory for cooling, the calculated supply temperature is set to 18°C.	Check the sensor and its connections.

INFORMATION MESSAGES

In the event of an information message, the green light lights up on the front, and a symbol with a service technician is displayed in the information window, until the message is reset. All information messages are automatically reset, if the cause is rectified. These messages are not registered in the alarm log.

No.	Text in display	Cause	Heat pump action.	Resets automatically when	May be due to/check
107	Sensor flt:BT7	The input for the sensor receives an unreasonably high or low value for longer than 2 seconds and is connected to VPB.	The display of BT7 is replaced by "----".	When the sensor has worked continuously for 60 seconds.	<ul style="list-style-type: none"> • Sensor not connected. • Open-circuit or defective sensor.
123	Sen flt: AZ30-BT23 out air s	The input for the sensor receives unreasonably high or low value for longer than 2 seconds.	QN38 closes.	When the sensor has worked continuously for 60 seconds.	<ul style="list-style-type: none"> • Sensor not connected. • Open-circuit or defective sensor.
140-142	compressor phase1-3 missing	Phase 1 to the compressor has been briefly absent.	Compressor blocked.	The phase returns.	<ul style="list-style-type: none"> • Phase fuses • Cable connections
145	Phase fault (incorrect phase sequence or missing phase).	Incorrect phase sequence or missing phase has been detected.	Compressor blocked.	Communication is restored. Otherwise switches to a permanent alarm, 45.	Check the fuses.
150	Temporary HP alarm	The high pressure switch has tripped once during a 150 minute period.	Compressor blocked.	When the HP pressure switch resets itself.	Check the flow.
151	Sen flt: CL11-BT51 pool temp sensor	Defective for longer than 5 seconds.	Pool pump stops.	When the sensor has worked continuously for 60 seconds.	<ul style="list-style-type: none"> • Sensor not connected. • Open-circuit or defective sensor.
152	Sens flt: CL12-BT51 pool temperature sensor	Defective for longer than 5 seconds.	Pool pump stops.	When the sensor has worked continuously for 60 s.	<ul style="list-style-type: none"> • Sensor not connected. • Open-circuit or defective sensor.
155	High hot gas temperature	The temperature exceeds the product's maximum permitted hot gas temperature.	None.	When BT14<90 °C.	
160	Lo Bri out	Brine out has reached set min temperature.	Compressor blocked.	The brine temperature has been raised 1 °C at brine in during a start attempt.	Incorrect settings.
161	High Brine in	Brine out has reached set max temperature.	Compressor blocked.	The brine temperature has fallen 1 °C at brine in during a start attempt.	Incorrect settings.
162	Hi cond. out	Brine out has reached max permitted temperature.	Compressor blocked.	The heating medium temperature has fallen 2 °C at heating medium in during a start attempt.	Incorrect settings.
163	High cond. in	Condenser in has reached max permitted temperature.	Compressor blocked.	The heating medium temperature has fallen 2 °C at heating medium in during a start attempt.	Incorrect settings.
165	Low pressure, climate system. External pressure switch for climate system indicates low pressure. Please check pressure and top up the system if necessary.	The AUX input "Pressure switch for climate system" is disconnected for more than 5 sec.	None.	It is reset when the alarm input has been closed for more than 5 seconds.	Check the boiler pressure.
170	Comm.fault In	Communication fault has occurred with input board AA3.	Only information.	Communication has resumed.	Check the communication cables and their connections.
171	Com.flit Base	Communication fault has occurred with base board AA2 or AA26.	Only information.	Communication has resumed.	Check the communication cables and their connections.
172	Comm.flit MC	Communication fault has occurred with soft-start board AA10.	Only information.	Communication has resumed.	Check the communication cables and their connections.

No.	Text in display	Cause	Heat pump action.	Resets automatically when	May be due to/check
173-179	Com.flt acc	Communication fault has occurred with the accessory card.	Accessory is blocked.	Communication has resumed.	<ul style="list-style-type: none"> Defective communication cables. The accessory is activated in the display while not connected with the communication cable. Incorrectly connected communication cable. Incorrectly set DIP switch. No electrical supply to the accessory card.
180	Anti-freeze	<ul style="list-style-type: none"> Outdoor temperature is below +3 °C at the same time as heating is blocked. Outdoor temperature is below +3 °C at the same time as the compressor is blocked by the alarm and additional heat is not permitted. Temperature sensor, outdoor (BT1) missing. 	Heating is permitted and the calculated supply temperature is set to min supply temperature.	The outdoor temperature exceeds +3 °C or heating is permitted.	Incorrect settings.
181	Problems at periodic increasing	Periodic hot water increase did not reach the stop temperature in 5 hours.	Only information.	Information is shown in the display.	Incorrect settings.
182	Load monitor active	Measured power consumption exceeds the fuse size that has been specified in menu 5.1.12.	The heat pump disconnects the electrical steps for the electrical additional heat step by step.	Power consumption reduced to below set fuse size in menu 5.1.12.	
183	Defrosting in progress		Defrosting in progress.		
184	Filter alarm	Time set in menu 5.3.1 has expired.	Only information.		
188-194	Com.flt acc	Communication fault has occurred with the accessory card.	Accessory is blocked.	Communication has resumed.	<ul style="list-style-type: none"> Defective communication cables. Incorrectly set DIP switch.
200	Com. fault inverter	Communication fault with inverter.	Only information.		
207	Com. flt accessory	Three communication faults in succession have occurred.	Only information.	Communication has resumed.	<ul style="list-style-type: none"> Defective communication cables. Incorrectly set DIP switch.
270	Compr. preheat in progress	Preheating of compressor.	Compressor blocked.	Stopped at the same time as compressor heater/crankcase heater.	
322	SPA not updated	Current spot price is not available.	Can influence the installation's priorities.	Check connection to the Internet.	
323	FIt: EQ1-BT25	The input for the sensor receives unreasonably high or low value for longer than 2 seconds.	Calculation of cooling DM performed with EQ1-BT25 is set to 0.		<ul style="list-style-type: none"> Open-circuit or short-circuit on sensor input. Defective sensor
333	hi. temp. out	The maximum temperature from the heat pump is exceeded.	Heating is blocked.	Resets automatically when the temperature is below 70 °C.	<ul style="list-style-type: none"> Undersized heating system. Incorrectly adjusted heating curve. Incorrect flow. Incorrectly connected additional heat.
334	high in temp.	The maximum temperature through the heat pump is exceeded. BT3 is higher than 65 °C in heating operation	Heating is blocked.	Resets automatically when the temperature is below 60 °C.	<ul style="list-style-type: none"> Undersized heating system. Incorrectly adjusted heating curve. Incorrect flow. Incorrectly connected additional heat.

No.	Text in display	Cause	Heat pump action.	Resets automatically when	May be due to/check
350	Sensor fault on BT50 room sensor.	The input for the sensor receives an unreasonably high or low value for longer than 2 seconds when the sensor is activated.		Resets automatically when the sensor has worked continuously for 60 seconds.	<ul style="list-style-type: none"> Open-circuit or short-circuit on sensor input. Defective sensor
351	Failed sensor calibration	Delta BT10-BT11> 2K after calibration.	Change from auto to manual brine pump speed.	Manual.	
353	Failed sensor calibration	Delta BT3-BT12> 2K after calibration.	Change from auto to manual pump speed.	Manual.	
359	Int temp OPT error	Alarm from the gas boiler (GBM).	None.	Manual.	
361-367	Sensor fault: EPxx-BT3 return line sensor	The input for the sensor receives unreasonably high or low value for longer than 2 seconds.		Resets automatically when the sensor has worked continuously for 60 seconds.	<ul style="list-style-type: none"> Open-circuit or short-circuit on sensor input. Defective sensor
369-370	Sensor fault: EP12-BT57/BT58	The input for the sensor receives unreasonably high or low value for longer than 2 seconds.	None.	Resets automatically when the sensor has worked continuously for 60 seconds.	<ul style="list-style-type: none"> Open-circuit or short-circuit on sensor input. Defective sensor
371	Freeze risk EP12-BT58	Ground water sensor BT58 is below its limit.	Blocks operation.	Resets automatically when the temperature rises above its limit value +2°C.	
420	Temporary com. fault with inverter	A temporary communication alarm has occurred.	The compressor is stopped.	Resets automatically 60 seconds after rectified alarm.	Main and group fuses and their cable connections.
422	Inverter alarm type II	A temporary alarm on the inverter's external input has occurred.	The compressor is stopped.	Resets automatically 60 seconds after rectified alarm.	Main and group fuses and their cable connections.
426	Temporary safety stop, inverter	A synchronisation fault in the inverter has occurred.	The compressor is stopped.	Resets automatically 30 minutes after rectified alarm.	Main and group fuses and their cable connections. <ul style="list-style-type: none"> Perform a complete restart of the heat pump. See page 57.
428	Temporary safety stop, inverter	A synchronisation fault in the inverter has occurred.	The compressor is stopped.	Resets automatically 60 seconds after rectified alarm.	Main and group fuses and their cable connections. <ul style="list-style-type: none"> Perform a complete restart of the heat pump. See page 57.
430	Temporary high mains voltage	A temporary over voltage has been registered by the inverter.	The compressor is stopped.	Resets automatically 60 seconds after rectified alarm.	Main and group fuses and their cable connections.
432	Inverter alarm type I	A temporary under voltage has been registered by the inverter.	The compressor is stopped.	Resets automatically 60 seconds after rectified alarm.	Main and group fuses and their cable connections.
434	Inverter alarm type I	The absence of a compressor phase has been registered by the inverter.	The compressor is stopped.	Resets automatically 60 seconds after rectified alarm.	Main and group fuses and their cable connections.
436	Temporary mains disturbance	A temporary mains disturbance has been registered by the inverter.	The compressor is stopped.	Resets automatically 60 seconds after rectified alarm.	Main and group fuses and their cable connections. <ul style="list-style-type: none"> Perform a complete restart of the heat pump. See page 57.
438	Safety temp. inv. achieved	The inverter has temporarily reached max. working temperature due to inadequate cooling.	The compressor is stopped.	Resets automatically 60 seconds after rectified alarm.	Insufficient circulation in the heating medium circuit. <ul style="list-style-type: none"> Bleed heat pump and climate system. Check that the particle filter is not blocked. Open any radiator/underfloor heating thermostats.
440	Inverter alarm type II	Max current in has been too high temporarily.	The compressor is stopped.	Resets automatically 60 seconds after rectified alarm.	Main and group fuses and their cable connections.

No.	Text in display	Cause	Heat pump action.	Resets automatically when	May be due to/check
442	Safety temp. inv. achieved	The inverter has temporarily reached max. working temperature due to inadequate cooling.	The compressor is stopped.	Resets automatically 60 seconds after rectified alarm.	Insufficient circulation in the heating medium circuit. <ul style="list-style-type: none"> • Bleed heat pump and climate system. • Check that the particle filter is not blocked. • Open any radiator/underfloor heating thermostats.
444	Temp. inverter protection	A temporary internal fault in the inverter has occurred.	The compressor is stopped.	Resets automatically 60 seconds after rectified alarm.	Main and group fuses and their cable connections. <ul style="list-style-type: none"> • Perform a complete restart of the heat pump. See page 57.
446	Temp. phase drop	The absence of a compressor phase has been registered by the inverter.	The compressor is stopped.	Resets automatically 60 seconds after rectified alarm.	Main and group fuses and their cable connections.
448	Failed compressor start	The compressor has run temporarily at a lower speed than the minimum permitted.	The compressor is stopped.	Resets automatically 60 seconds after rectified alarm.	Main and group fuses and their cable connections.
452	High current load, compressor	The current to the compressor has been temporarily too high.	The compressor is stopped.	Resets automatically 60 seconds after rectified alarm.	Main and group fuses and their cable connections.
454	Temporary high power load, compressor	The power load to the compressor has been temporarily too high.	The compressor is stopped.	Resets automatically 60 seconds after rectified alarm.	Main and group fuses and their cable connections.
482	The inverter is limited due to temperature conditions	Inverter status section for slowing down has been active for 10 minutes	None.	It is reset automatically when the inverter reaches its set point value.	Insufficient circulation in the heating medium circuit. <ul style="list-style-type: none"> • Bleed heat pump and climate system. • Check that the particle filter is not blocked. • Open any radiator/underfloor heating thermostats.
508	Inv. lost contact with the mains.	The inverter has lost contact with the mains network.	No action.	It is reset automatically when the section has not been active for 60 s.	Check fuses and mains voltage to the inverter.
509	Inverter over-temperature	The ambient temperature is too high for the inverter for NIBE PV.	No action.	It is reset automatically when the section has not been active for 60 s.	Check the temperature in the inverter's installation area.
900	Country not selected	Country not defined.	Stops in the position reached when the message was displayed.	Resets when country is selected in menu 5.12.	
995	ext. alarm	Status of AUX-in.	None.		
996	blocked	Additional heat externally blocked.	None.		
997	blocked	Compressor externally blocked.	None.		
998	starts	Display has restarted.	None.		

Item register

A

Alarm, 54
Alarm list, 57

B

Back button, 9

C

Control, 9, 13
 Control - Introduction, 9
 Control - Menus, 13
Control - Introduction, 9
Control knob, 9
Control - Menus, 13
 Menu 1 - INDOOR CLIMATE, 13
 Menu 2 - HOT WATER, 21
 Menu 3 - INFO, 24
 Menu 4 - HEAT PUMP, 26
 Menu 5 - SERVICE, 35

D

Display, 9
Display unit, 9
 Back button, 9
 Control knob, 9
 Display, 9
 OK button, 9
 Status lamp, 9
 Switch, 9
Disturbances in comfort
 Alarm, 54
 Alarm list, 57
 Manage alarm, 54
 Troubleshooting, 54
Draining the climate system, 47
Draining the hot water heater, 47
Drawing out the cooling module, 49

E

Emptying the brine system, 48

H

Helping the circulation pump to start, 48
Help menu, 12

I

Important information, 4
 Installation data, 4
 Recovery, 7
 Safety information, 5
Installation data, 4

M

Manage alarm, 54
Menu 1 - INDOOR CLIMATE, 13
Menu 2 - HOT WATER, 21
Menu 3 - INFO, 24
Menu 4 - HEAT PUMP, 26
Menu 5 - SERVICE, 35
Menu system, 9
 Help menu, 12
 Operation, 11
 Scroll through the windows, 12
 Selecting menu, 11
 Selecting options, 11
 Setting a value, 11
 Use the virtual keyboard, 12

O

OK button, 9
Operation, 11

S

Safety information, 5
 Safety precautions, 6
 Symbols, 5
Safety precautions, 6
Scroll through the windows, 12
Selecting menu, 11
Selecting options, 11
Service, 47
 Service actions, 47
Service actions, 47
 Draining the climate system, 47
 Draining the hot water heater, 47
 Drawing out the cooling module, 49
 Emptying the brine system, 48
 Helping the circulation pump to start, 48
 Standby mode, 47
 USB service outlet, 52
Setting a value, 11
Standby mode, 47
Status lamp, 9
Switch, 9
Symbols, 5

T

Troubleshooting, 54

U

USB service outlet, 52
Use the virtual keyboard, 12

Contact information

AUSTRIA

KNV Energietechnik GmbH
Gahberggasse 11, 4861 Schörfling
Tel: +43 (0)7662 8963-0
mail@knv.at
knv.at

FINLAND

NIBE Energy Systems Oy
Juurakkotie 3, 01510 Vantaa
Tel: +358 (0)9 274 6970
info@nibe.fi
nibe.fi

GREAT BRITAIN

NIBE Energy Systems Ltd
3C Broom Business Park,
Bridge Way, S41 9QG Chesterfield
Tel: +44 (0)330 311 2201
info@nibe.co.uk
nibe.co.uk

POLAND

NIBE-BIAWAR Sp. z o.o.
Al. Jana Pawla II 57, 15-703 Bialystok
Tel: +48 (0)85 66 28 490
biawar.com.pl

CZECH REPUBLIC

Družstevní závody Dražice - strojírna
s.r.o.
Dražice 69, 29471 Benátky n. Jiz.
Tel: +420 326 373 801
nibe@nibe.cz
nibe.cz

FRANCE

NIBE Energy Systems France SAS
Zone industrielle RD 28
Rue du Pou du Ciel, 01600 Reyrieux
Tél: 04 74 00 92 92
info@nibe.fr
nibe.fr

NETHERLANDS

NIBE Energietechnik B.V.
Energieweg 31, 4906 CG Oosterhout
Tel: +31 (0)168 47 77 22
info@nibenl.nl
nibenl.nl

SWEDEN

NIBE Energy Systems
Box 14
Hannabadsvägen 5, 285 21 Markaryd
Tel: +46 (0)433-27 30 00
info@nibe.se
nibe.se

DENMARK

Vølund Varmeteknik A/S
Industrivej Nord 7B, 7400 Herning
Tel: +45 97 17 20 33
info@volundvt.dk
volundvt.dk

GERMANY

NIBE Systemtechnik GmbH
Am Reiherpfahl 3, 29223 Celle
Tel: +49 (0)5141 75 46 -0
info@nibe.de
nibe.de

NORWAY

ABK-Qviller AS
Brobekkeveien 80, 0582 Oslo
Tel: (+47) 23 17 05 20
post@abkqviller.no
nibe.no

SWITZERLAND

NIBE Wärmetechnik c/o ait Schweiz AG
Industriepark, CH-6246 Altishofen
Tel. +41 (0)58 252 21 00
info@nibe.ch
nibe.ch

For countries not mentioned in this list, contact NIBE Sweden or check nibe.eu for more information.

