

User manual

**NIBE**

# Air/water heat pump

## **NIBE S2125**

---



UHB EN 2421-1  
731849



# Table of Contents

1	Important information _____	4
	Installation data _____	4
	Symbols _____	5
	Serial number _____	5
2	Installation function _____	6
3	Control of S2125 _____	8
4	Maintenance of S2125 _____	9
	Regular checks _____	9
	In event of long power cuts _____	10
	Silent mode _____	10
	Fan de-icing _____	10
	Updating the software _____	10
5	Disturbances in comfort _____	11
	Troubleshooting _____	11
	Contact information _____	15

# Important information

For the latest version of the product's documentation, see [nibe.eu](http://nibe.eu).

## Installation data

Product	S2125
Serial number	
Installation date	
Installer	

Accessories	

Serial number must always be given.

Certification that the installation is carried out according to instructions in the accompanying installer manual and applicable regulations.

Date \_\_\_\_\_ Signed \_\_\_\_\_

## Symbols

Explanation of symbols that may be present in this manual.



### CAUTION!

This symbol indicates danger to person or machine.



### NOTE!

This symbol indicates important information about what you should observe when maintaining your installation.



### TIP!

This symbol indicates tips on how to facilitate using the product.

## Serial number

The serial number can be found on the rear cover and at the bottom on the side.

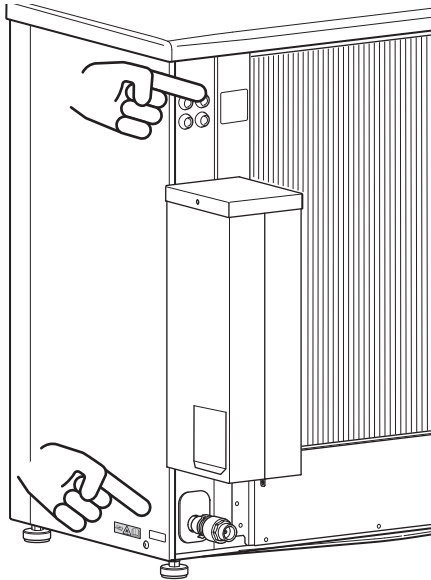

### NOTE!

You need the product's (14 digit) serial number for servicing and support.

# Installation function

An air/water heat pump installation uses the outdoor air to heat up a home. The conversion of the outdoor air's energy into residential heating occurs in three different circuits. From the outdoor air, (1), free heat energy is retrieved and

transported to the heat pump. The heat pump increases the retrieved heat's low temperature to a high temperature in the refrigerant circuit, (2). The heat is distributed around the building in the heating medium circuit, (3).

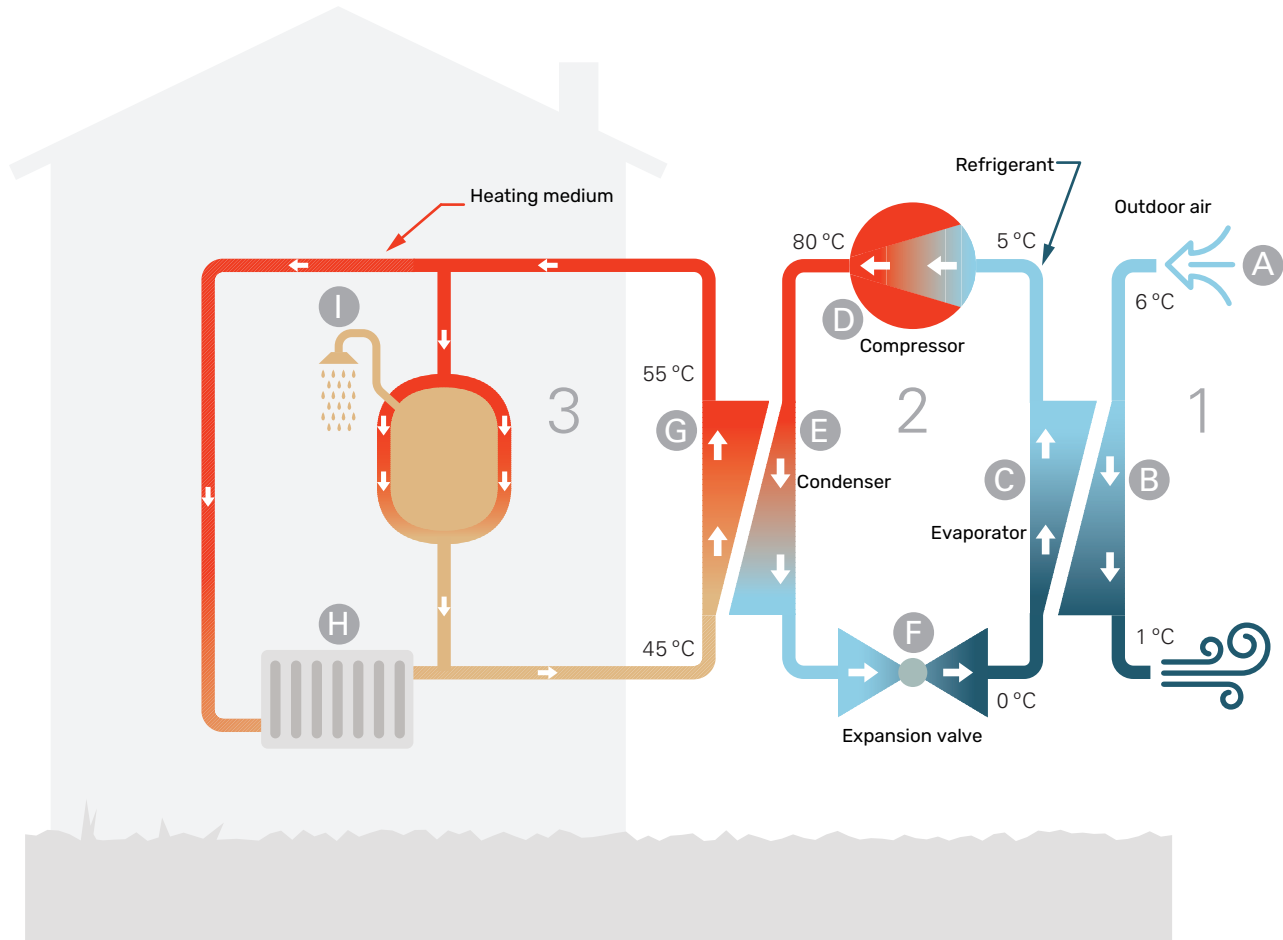

The temperatures are only examples and may vary between different installations and time of year.

### **Outdoor air**

- A** The outdoor air is drawn into the outdoor unit.
- B** The fan then routes the air to the outdoor unit's evaporator. Here, the air releases thermal energy to the refrigerant and the air's temperature drops. The cold air is then blown out of the outdoor unit.

### **Refrigerant circuit**

- C** In a closed system in the outdoor unit, a gas (a refrigerant) circulates, which also passes the evaporator. The refrigerant has a very low boiling point. In the evaporator, the refrigerant collects the heat energy from the outdoor air and starts to boil.
- D** The gas that is produced during boiling is routed into an electrically powered compressor. When the gas is compressed, the pressure increases and the gas's temperature increases considerably, from 0 °C to approx 80 °C.
- E** From the compressor, gas is forced into a heat exchanger, condenser, where it releases heat energy to the indoor module, whereupon the gas is cooled and condenses to a liquid form again.
- F** As the pressure is still high, the refrigerant can pass an expansion valve, where the pressure drops so that the refrigerant returns to its original temperature. The refrigerant has now completed a full cycle. It is routed to the evaporator again and the process is repeated.

### **Heat medium circuit**

- G** The heat energy that the refrigerant produces in the condenser is retrieved by the indoor unit's heating medium, water, which is heated to approx. 55 °C (supply temperature).
- H** The heating medium circulates in a closed system and transports the heated water's heat energy to the house radiators/heating coils.
- I** The indoor module's integrated charge coil is placed in the boiler section. The water in the coil heats up the surrounding domestic hot water.

# Control of S2125

S2125 is controlled in different ways, depending on your system. You control the heat pump via your indoor module or control module.

See the Installer Manual for the indoor module/control module.

During installation, the installation engineer adjusts the necessary settings for the heat pump in the indoor module or control module, so that the heat pump works optimally in your system.



# Maintenance of S2125

## Regular checks

When your heat pump is located outdoors some external maintenance is required.



### CAUTION!

Insufficient maintenance can cause serious damage to S2125, which is not covered by the guarantee.

## CHECKING GRILLES AND BOTTOM PANEL ON S2125

Check regularly throughout the year that the grille is not clogged by leaves, snow or anything else.

You should be particularly vigilant during windy conditions and/or in the event of snow, as the grille can become blocked.

Check that the back is free from dirt and leaves.

Also check that the drain holes in the bottom panel are free from dirt and leaves.

Regularly check that condensation is routed away correctly through the condensation pipe. Ask your installer for assistance if required.

## Keep free of snow and ice

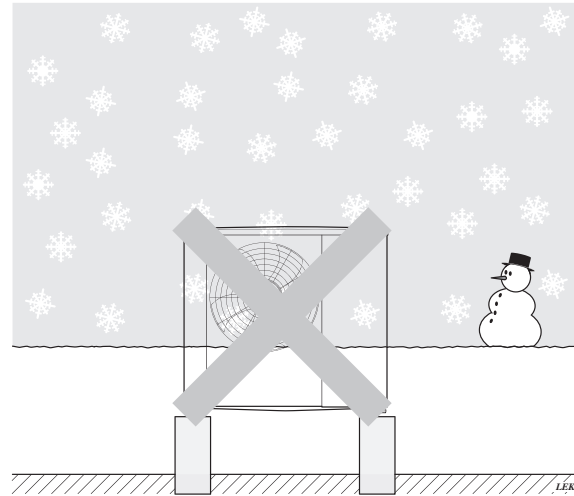

Prevent snow from building up and covering the grilles and drain holes on S2125.

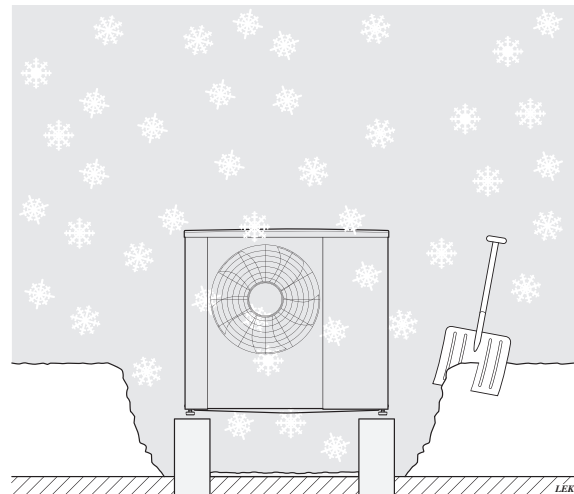

Keep free of snow and/or ice.

## CLEANING THE OUTER CASING

If necessary the outer casing can be cleaned using a damp cloth.

Care must be exercised so that the heat pump is not scratched when cleaning. Avoid spraying water into the grilles or the sides so that water penetrates into S2125. Prevent S2125 coming into contact with alkaline cleaning agents.

## ACTUATING THE SAFETY VALVE (FL2)

The safety valve must be actuated regularly, to remove dirt and to check that it is not blocked.

Remember to also check that the vent valve is working.

## In event of long power cuts

In the event of prolonged power failure, we recommend draining the part of the heating system located outdoors. This is made easier if shut-off valves are installed. Ask your installer if you are uncertain.



### NOTE!

Also disconnect the non-return valve (RM1.2) to prevent the condenser from freezing.

## Silent mode

The heat pump can be set to "Silent mode", which reduces the heat pump's noise level. This function can help when S2125 has to be placed in noise-sensitive areas. The function should only be used for limited periods, because S2125 might not reach its dimensioned power.

## Fan de-icing

### VVM S / SMO S

#### Menu 4.11.3 - Fan de-icing

### VVM / SMO

#### Menu 4.9.7 - tools

#### **FAN DE-ICING**

Setting range: off/on

#### **CONTINUOUS FAN DE-ICING**

Setting range: off/on

*Fan de-icing:* Here, you set whether the "fan de-icing" function will be activated during the next "active defrosting". This can be activated if ice/snow sticks to the fan, grille or fan cone, which may be noticed due to abnormal fan noise from the outdoor unit.

"Fan de-icing" means that the fan, grille and fan cone are heated using hot air from the evaporator (EP1).

*Continuous fan de-icing:* There is the option to set recurring de-icing. In this case, every tenth defrosting will be "Fan de-icing". (This can increase annual energy consumption.)

## Updating the software

Information about updating software can be found in the Installer Manual for your indoor module or control module.

# Disturbances in comfort

In most cases, the indoor module/control module notes a malfunction (a malfunction can lead to disturbance in comfort) and indicates this with alarms and action instructions in the display.



## CAUTION!

Work behind covers secured by screws may only be carried out by, or under the supervision of, a qualified installation engineer.

## Troubleshooting

If the operational interference is not shown in the display the following tips can be used:

### BASIC ACTIONS

Start by checking the following:

- All supply cables to the heat pump are connected.
- Group and main fuses of the accommodation.
- The property's earth circuit breaker.
- The heat pump's fuse / automatic protection.
- The indoor module's/control module's fuses.
- The indoor module's/control module's temperature limiters.
- That S2125 does not have any external damage.

### ICE BUILD-UP IN THE FAN, GRILLE AND/OR FAN CONE

Set the "Fan de-icing" function in the indoor module/control module. For more information, see the section "Control – Heat pump EB101" in the Installer Manual.

If problems arise, contact your installer.

### WATER BELOW S2125 (LARGER AMOUNT)

- Fit accessory KVR to divert condensation from the air/water heat pump.
- Check that the water drainage via the condensation pipe (KVR) is working.







## Contact information

### **AUSTRIA**

KNV Energietechnik GmbH  
Gahberggasse 11, 4861 Schörfling  
Tel: +43 (0)7662 8963-0  
mail@knv.at  
knv.at

### **FINLAND**

NIBE Energy Systems Oy  
Juurakkotie 3, 01510 Vantaa  
Tel: +358 (0)9 274 6970  
info@nibe.fi  
nibe.fi

### **GREAT BRITAIN**

NIBE Energy Systems Ltd  
3C Broom Business Park,  
Bridge Way, S41 9QG Chesterfield  
Tel: +44 (0)330 311 2201  
info@nibe.co.uk  
nibe.co.uk

### **POLAND**

NIBE-BIAWAR Sp. z o.o.  
Al. Jana Pawla II 57, 15-703 Bialystok  
Tel: +48 (0)85 66 28 490  
biawar.com.pl

### **CZECH REPUBLIC**

Družstevní závody Dražice - strojírna  
s.r.o.  
Dražice 69, 29471 Benátky n. Jiz.  
Tel: +420 326 373 801  
nibe@nibe.cz  
nibe.cz

### **FRANCE**

NIBE Energy Systems France SAS  
Zone industrielle RD 28  
Rue du Pou du Ciel, 01600 Reyrieux  
Tél: 04 74 00 92 92  
info@nibe.fr  
nibe.fr

### **NETHERLANDS**

NIBE Energietechnik B.V.  
Energieweg 31, 4906 CG Oosterhout  
Tel: +31 (0)168 47 77 22  
info@nibenl.nl  
nibenl.nl

### **SWEDEN**

NIBE Energy Systems  
Box 14  
Hannabadsvägen 5, 285 21 Markaryd  
Tel: +46 (0)433-27 30 00  
info@nibe.se  
nibe.se

### **DENMARK**

Vølund Varmeteknik A/S  
Industrivej Nord 7B, 7400 Herning  
Tel: +45 97 17 20 33  
info@volundvt.dk  
volundvt.dk

### **GERMANY**

NIBE Systemtechnik GmbH  
Am Reiherpfahl 3, 29223 Celle  
Tel: +49 (0)5141 75 46 -0  
info@nibe.de  
nibe.de

### **NORWAY**

ABK-Qviller AS  
Brobekkeveien 80, 0582 Oslo  
Tel: (+47) 23 17 05 20  
post@abkqviller.no  
nibe.no

### **SWITZERLAND**

NIBE Wärmetechnik c/o ait Schweiz AG  
Industriepark, CH-6246 Altishofen  
Tel. +41 (0)58 252 21 00  
info@nibe.ch  
nibe.ch

For countries not mentioned in this list, contact NIBE Sweden or check [nibe.eu](http://nibe.eu) for more information.

NIBE Energy Systems  
Hannabadsvägen 5  
Box 14  
SE-285 21 Markaryd  
info@nibe.se  
nibe.eu

UHB EN 2421-1 731849

This is a publication from NIBE Energy Systems. All product illustrations, facts and data are based on the available information at the time of the publication's approval.

NIBE Energy Systems makes reservations for any factual or printing errors in this publication.

©2024 NIBE ENERGY SYSTEMS

