

## HRV unit

# NIBE ERS S40-400

The NIBE ERS S40-400 is a HRV unit with low energy consumption, a level of efficiency up to 85%, a built-in humidity sensor and a reheater. Thanks to the rotating heat exchanger, the moisture in the air is recycled. The HRV unit is used in houses up to 250 m<sup>2</sup> and can even be placed in cold spaces. NIBE ERS S40-400 is delivered in left-hand version with regard to duct connection, but can also be converted to right-hand version.

The NIBE ERS S40-400 is installed together with a NIBE S series ground-source heat pump or a NIBE air/waterheat pump with an S series VVM/SMO to constitute a complete heat and ventilation system. The HRV unit is easily controlled by the heat pump.

Thanks to smart technology, the product gives you control over your energy consumption and will be a key part of your connected lifestyle. The efficient control system automatically adjusts the indoor climate for maximum comfort, and you do nature a favour at the same time.

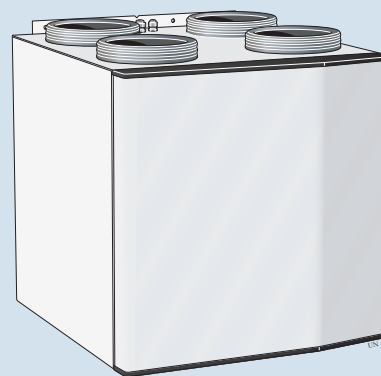

- **The HRV unit with high temperature efficiency, low energy consumption and humidity control.**
- **For houses with balanced ventilation, a complete solution is offered together with NIBE's S series models.**
- **Easy to control and part of your smart home in combination with a NIBE heat pump.**

# This is how ERS S40 works

## Principle

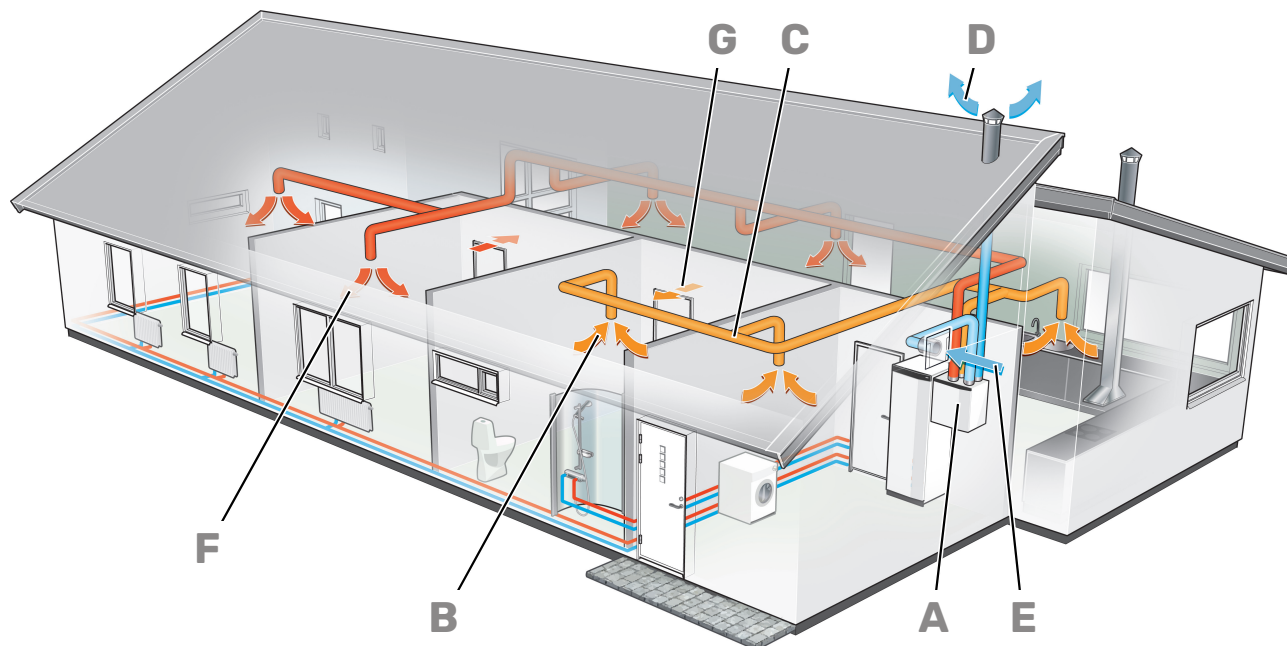

ERS S40 is an HRV unit with inbuilt fans and a rotating heat exchanger.

Energy is recovered from the ventilation air and supplied to your home, which reduces energy costs considerably.

The unit is intended for both new installations and replacement in houses or similar.

ERS S40 is suitable for ventilation systems where high thermal efficiency and low energy consumption are required.

- A** ERS S40 ventilates your home and heats the supply air.
- B** The warm room air is drawn into the air duct system.
- C** The warm room air is fed to ERS S40.
- D** The room air is released when it has passed ERS S40. The air temperature has then been reduced as ERS S40 has extracted the energy in the room air.
- E** Outdoor air is drawn into ERS S40.
- F** Air is blown out into rooms with supply air inlets.
- G** Air is transferred from rooms with supply air valves to rooms with exhaust air valves.

# Good to know about ERS S40

## Transport and storage

ERS S40 should be transported and stored in the dry.

## Supplied components

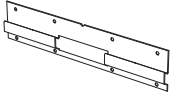

Rail for wall mounting



4 x feet

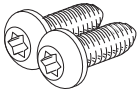

2 x screws

## Installation and positioning

ERS S40 can be installed on a wall or placed on a horizontal surface. For wall installation, place the enclosed rail on a solid wall. Noise from the fans might be transferred to the rail. When placing on a horizontal surface, fit the enclosed feet on the underside of ERS S40. It is important for the surface where ERS S40 is placed to be stable and to withstand the weight of the unit.

- Install with its back to an outside wall, ideally in a room where noise does not matter, in order to eliminate noise problems. If this is not possible, avoid placing it against a wall behind a bedroom or other room where noise may be a problem.
- Wherever the unit is located, walls to sound sensitive rooms should be fitted with sound insulation.
- The HRV unit's installation area always has to have a temperature of at least  $-38\text{ }^{\circ}\text{C}$  and max.  $50\text{ }^{\circ}\text{C}$ .

## INSTALLATION AREA

Leave a free space of 800 mm in front of the product.

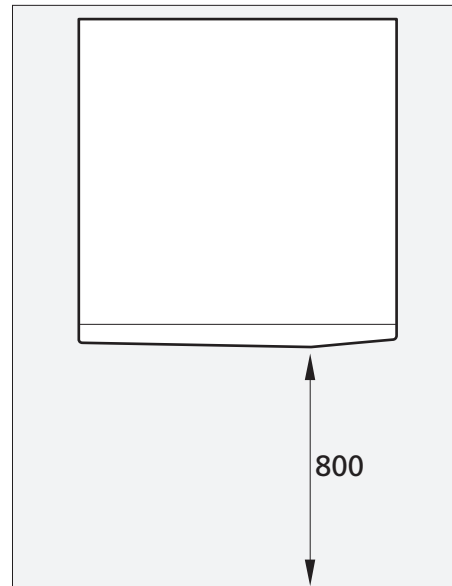

Ensure that there is sufficient space (300 mm) for connecting ventilation ducts.

# Installation

## Ventilation



Connect ERS S40 so that all the exhaust air, except kitchen duct air (kitchen fan), passes through the heat exchanger in the product.

- The ventilation flow must comply with the applicable national standards.
- The supply air flow must be lower than the exhaust air flow to prevent over pressure in the house.
- Provision must be made for inspection and cleaning of the duct.
- The air duct system must be a minimum of air tightness class B.
- To prevent fan noise being transferred to the ventilation devices, install silencers in suitable locations in the duct system.
- Because the extract air and outdoor air temperature is/becomes cold, the extract air and outdoor air duct must be insulated using diffusion-proof material along its entire length.
- Exhaust and supply air ducts that are routed in cold areas must be insulated.
- All joins in the ducting must be sealed to prevent leakage.
- The air must be routed to the outdoor air duct through an outer wall grille in the facade. The outer wall grille must be installed so that it is protected from the weather and must be designed so that no rainwater and/or snow can penetrate the facade or follow the air into the duct.
- When positioning the outdoor air and extract air hood/grille, bear in mind that the two air flows must not short circuit to prevent the extract air from being drawn into ERS S40 again.
- A duct in a masonry chimney stack must not be used for extract air or outdoor air.
- If a stove or similar is installed, it must have airtight doors. It must also be able to take combustion air from outside.
- Incorrect adjustment of the ventilation may lead to reduced installation efficiency and thus poorer operating economy, a poorer indoor climate and moisture damage in the building.

## SETTING THE FAN CAPACITY

Select the ventilation capacity steplessly in the display.

## Ventilation capacity

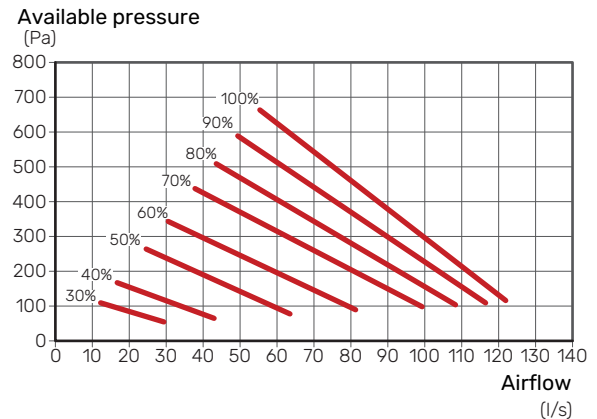

## Fan rating<sup>1</sup>

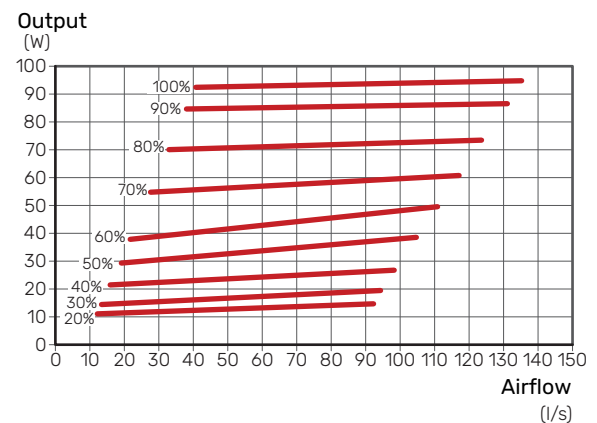

<sup>1</sup>The diagram shows the power consumption per fan.

## VENTILATION CONNECTIONS

### Left-handed version

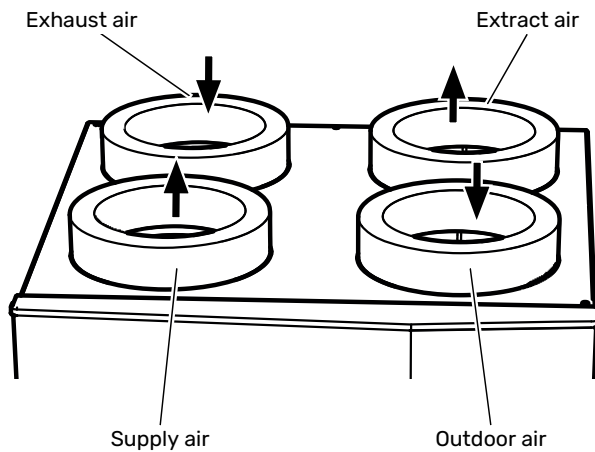

### Right-hand version

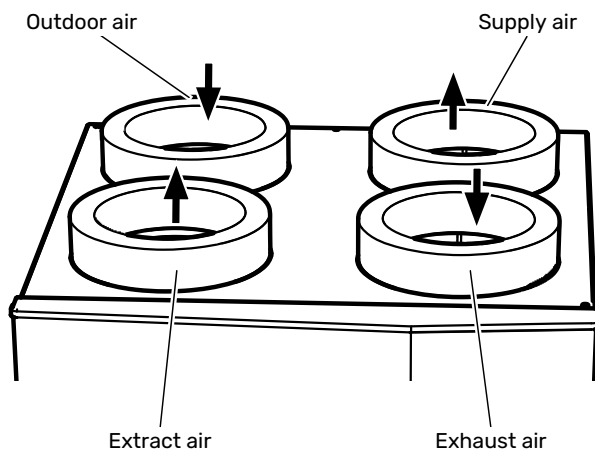

## Electrical connections



Disconnect ERS S40 before insulation testing the house wiring.

To prevent interference, sensor cables to external

- connections must not be laid close to high voltage cables.
- If the supply cable is damaged, only NIBE, its service representative or similar authorised person may replace it to prevent any danger and damage.

ERS S40 is equipped with a communication cable from the factory (cable length 2.4 m), which is connected to a circuit board in the heat pump. It is also equipped with a supply cable with a plug (cable length 2.4 m).

Electrical installation and service must be carried out under the supervision of a qualified electrician. Electrical installation and wiring must be carried out in accordance with the stipulations in force.

# Technical data

## Dimensions

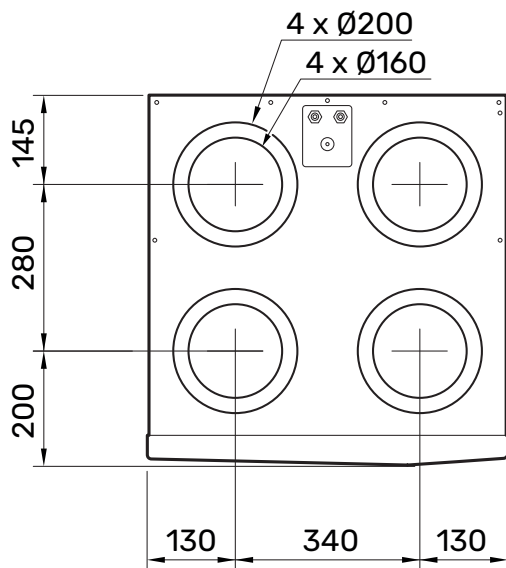
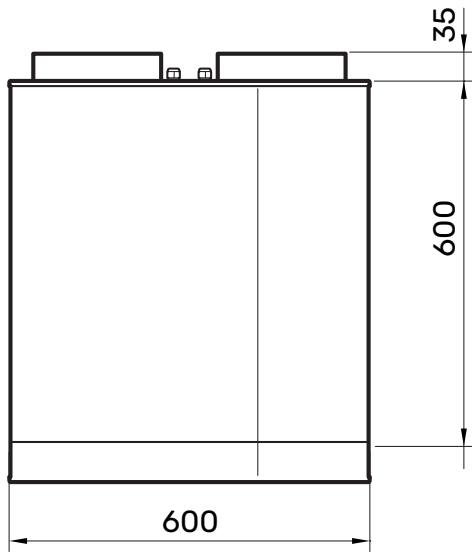

## Accessories

Not all accessories are available on all markets.

Detailed information about the accessories and complete accessories list available at [nibe.eu](http://nibe.eu).

### TOP CABINET TOC 40

Top cabinet that conceals the ventilation ducts and reduces the sound to the installation room.

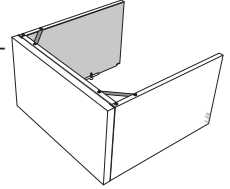

# Technical specifications

Type		ERS S40
<b>Electrical data</b>		
Supply voltage	V	230 V ~ 50Hz
Fuse	A	10
Power, re-heater	W	1000
Driving power fan	W	2 x 90
Enclosure class		IP X1B
<b>Ventilation</b>		
Filter type, exhaust air filter		Coarse 65%
Filter type, supply air filter		ePM1 55%
<b>Noise</b>		
Sound power level ( $L_{W(A)}$ ) <sup>1</sup>	dB(A)	51
Sound pressure level ( $L_{P(A)}$ ) at 1 m <sup>2</sup>	dB(A)	40
<b>Pipe connections</b>		
Ventilation $\emptyset$	mm	160
<b>Miscellaneous</b>		
Efficiency class <sup>3</sup>		A
Length, supply cable	m	2.4
Length, communication cable	m	2.4
Width	mm	600
Height	mm	600
Depth	mm	620
Weight	kg	45
Part No.		066 242

<sup>1</sup> 89 l/s (320 m<sup>3</sup>/h) at 50 Pa

<sup>2</sup> 72 l/s (260 m<sup>3</sup>/h) at 50 Pa

<sup>3</sup> Scale for efficiency class: A+ to G.

## Temperature and humidity efficiency according to EN 13141-7

Temperature and humidity efficiency

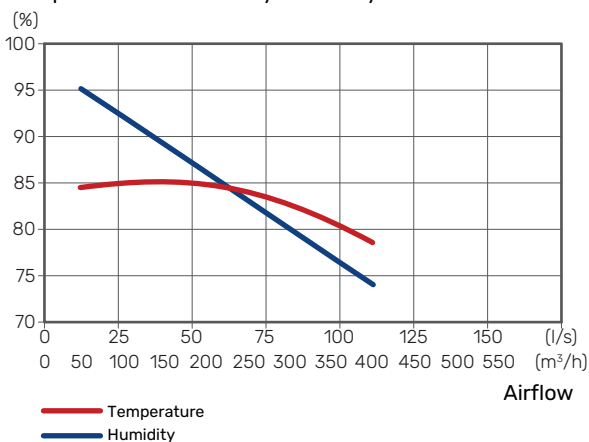

RPM: 25 Outdoor air: 7 °C RH 80% Exhaust air: 20 °C RH 38%

# Sustainable energy solutions since 1952

---

NIBE has been manufacturing energy-efficient and sustainable climate solutions for your home for 70 years. It all began in Markaryd, in the southern Swedish province of Småland, and we recognise our Nordic heritage by utilising the power of nature. We combine renewable energy with smart technology to offer efficient solutions, allowing us to work together to create a more sustainable future.

Regardless of whether it is a chilly winter's day or a warm afternoon in the summer sun, we need a balanced indoor climate that allows us to enjoy a comfortable life, whatever the weather. Our extensive range of products supply your home with cooling, heating, ventilation and hot water, making it possible for you to create a pleasant indoor climate with little impact on the environment.

NIBE Energy Systems  
Box 14, SE-285 21 Markaryd  
nibe.eu



---

This product sheet is a publication from NIBE Energy Systems. All product illustrations, facts and data are based on current information at the time of the publication's approval. NIBE Energy Systems makes reservations for any factual or printing errors in this product sheet.