



## HRV unit

# NIBE ERS 20-300

**The NIBE ERS 20-300 is a HRV unit with high temperature efficiency up to 92% and low energy consumption.**

The NIBE ERS 20-300 is designed for installation with a NIBE ground source heat pump or a NIBE air/water heat pump for a complete heating and ventilation system. The HRV unit is easily controlled by the heat pump.

Thanks to smart technology, the product gives you control over your energy consumption and will be a key part of your connected lifestyle. The efficient control system automatically adjusts the indoor climate for maximum comfort, and you do nature a favour at the same time.

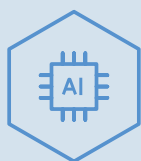
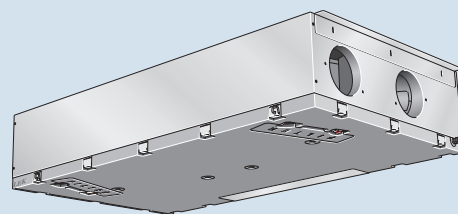

- **The heat recovery ventilation unit with high temperature efficiency and low energy consumption.**
- **Together with the NIBE ground source or air/water heat pump, it provides an integrated solution in houses with balanced ventilation.**
- **Easy to control and part of your smart home in combination with a NIBE heat pump.**

# This is how ERS 20 works

## Principle

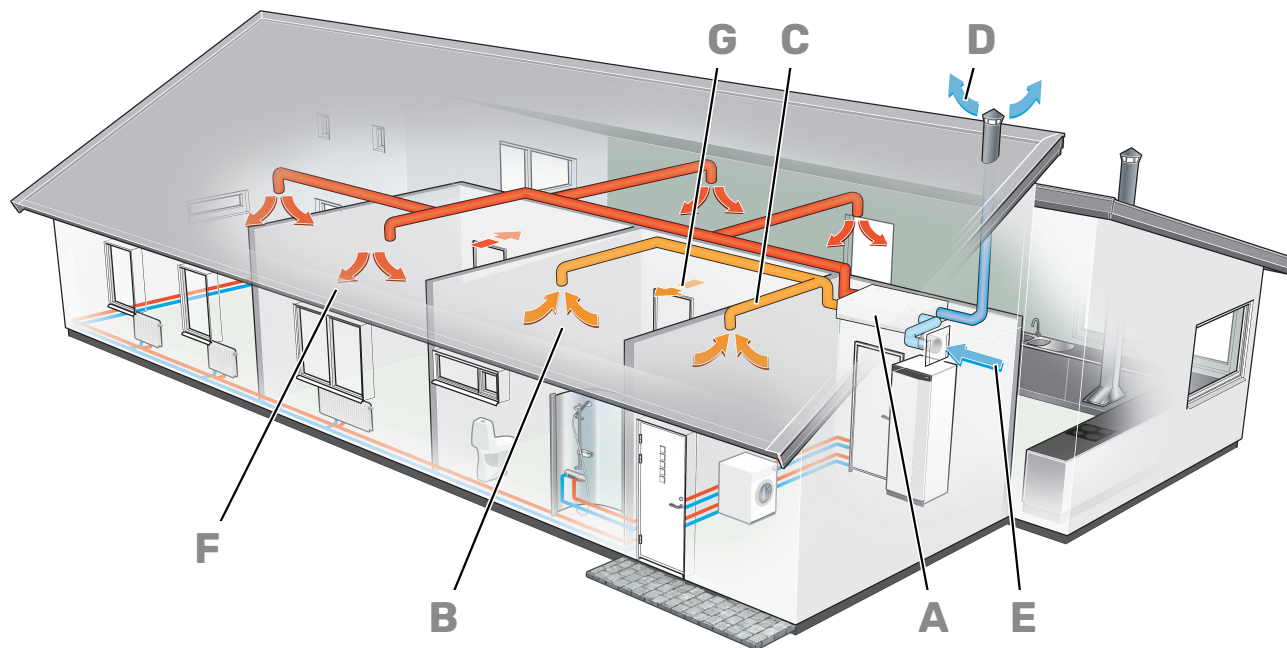

ERS 20 is an HRV unit with inbuilt fans and counter-current heat exchanger.

Energy is recovered from the ventilation air and supplied to your home, which reduces energy costs considerably.

The unit is intended for both new installations and replacement in houses or similar.

ERS 20 is suitable for ventilation systems where high thermal efficiency and low energy consumption are required.

- A** ERS 20 ventilates your home and heats the supply air.
- B** The warm room air is drawn into the air duct system.
- C** The warm room air is fed to ERS 20.
- D** The room air is released when it has passed ERS 20. The air temperature has then been reduced as ERS 20 has extracted the energy in the room air.
- E** Outdoor air is drawn into ERS 20.
- F** Air is blown out into rooms with supply air inlets.
- G** Air is transferred from rooms with supply air valves to rooms with exhaust air valves.

# Good to know about ERS 20

## Transport and storage

ERS 20 should be transported and stored in the dry.

## Supplied components

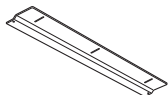

2 x roof brackets

## Installation and positioning

ERS 20 is installed in the roof using the enclosed roof brackets. Noise from the fans can be transmitted to the brackets.

- Install ERS 20 on an outside wall, ideally in a room where noise does not matter, in order to eliminate noise problems. If this is not possible, avoid placing it against a wall adjoining a bedroom or other room where noise may be a problem.
- Wherever the unit is located, walls to sound sensitive rooms should be fitted with sound insulation.
- Condensation water comes from the HRV unit. A condensation outlet with a water seal must be installed and routed to an internal drain.
- The HRV unit's installation area always has to have a temperature of at least 10 °C and max. 35 °C.

## INSTALLATION AREA

Leave a free space of 1000 mm in front of the product.

Because servicing is carried out from below, a free space of 1,600 mm is recommended below the unit.

Ensure that there is sufficient space (300 mm) for connecting ventilation ducts.

# Installation

## Condensation water drain

ERS 20 can produce several litres of condensation water per day. It is therefore important that the condensation outlet is correctly executed and the HRV unit installed horizontally.

Check that the water seal is airtight and firmly in position. The connection must be made so that the user can check and top up the water seal, without opening ERS 20.

The connection for the condensation outlet measures  $\varnothing 15$  mm.

## Ventilation



Connect ERS 20 so that all the exhaust air, except kitchen duct air (kitchen fan), passes through the heat exchanger in the product.

- The ventilation flow must comply with the applicable national standards.
- The supply air flow must be lower than the exhaust air flow to prevent over pressure in the house.
- Provision must be made for inspection and cleaning of the duct.
- The air duct system must be a minimum of air tightness class B.
- To prevent fan noise being transferred to the ventilation devices, install silencers in suitable locations in the duct system.
- Because the extract air and outdoor air temperature is/becomes cold, the extract air and outdoor air duct must be insulated using diffusion-proof material along its entire length.
- Exhaust and supply air ducts that are routed in cold areas must be insulated.
- All joins in the ducting must be sealed to prevent leakage.
- The air must be routed to the outdoor air duct through an outer wall grille in the facade. The outer wall grille must be installed so that it is protected from the weather and must be designed so that no rainwater and/or snow can penetrate the facade or follow the air into the duct.
- When positioning the outdoor air and extract air hood/grille, bear in mind that the two air flows must not short circuit to prevent the extract air from being drawn into ERS 20 again.
- A duct in a masonry chimney stack must not be used for extract air or outdoor air.
- If a stove or similar is installed, it must have airtight doors. It must also be able to take combustion air from outside.

- Incorrect adjustment of the ventilation may lead to reduced installation efficiency and thus poorer operating economy, a poorer indoor climate and moisture damage in the building.

## SETTING THE FAN CAPACITY

Select the ventilation capacity steplessly in the display.

### Ventilation capacity

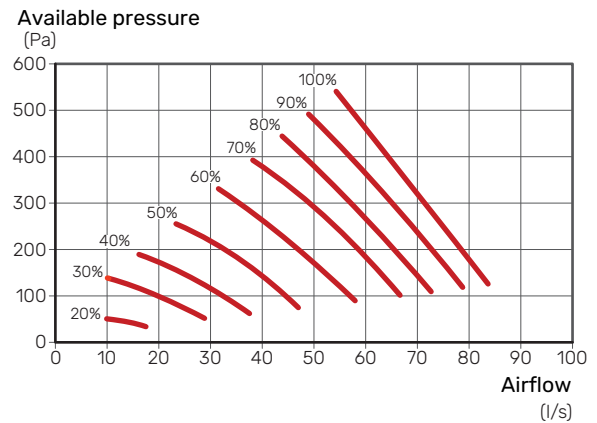

### Fan rating<sup>1</sup>

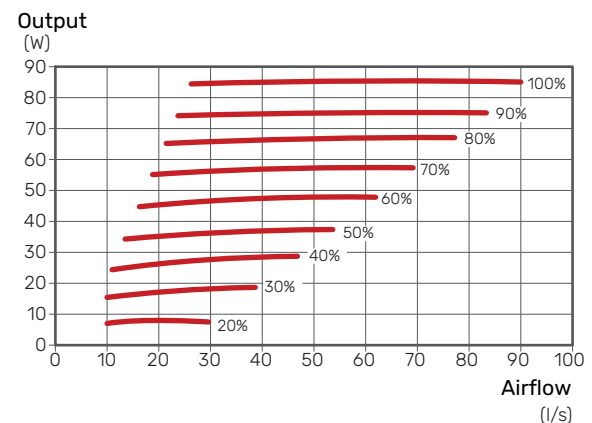

<sup>1</sup>The diagram shows the power consumption per fan.

## VENTILATION CONNECTIONS

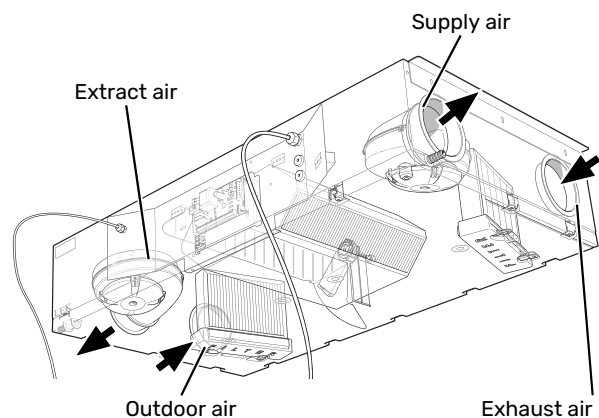

## Electrical connections



Disconnect ERS 20 before insulation testing the house wiring.

To prevent interference, sensor cables to external

- connections must not be laid close to high voltage cables.
- If the supply cable is damaged, only NIBE, its service representative or similar authorised person may replace it to prevent any danger and damage.

ERS 20 is equipped with a communication cable from the factory (cable length 2.0 m), which is connected to a circuit board in the heat pump. It is also equipped with a supply cable with a plug (cable length 2.4 m).

Electrical installation and service must be carried out under the supervision of a qualified electrician. Electrical installation and wiring must be carried out in accordance with the stipulations in force.

## Functions

### AIR HEATER EAH 20

In houses where the outdoor temperature can be continuously lower than  $-5^{\circ}\text{C}$ , ERS 20 should be supplemented with an electrical air heater (EAH 20). In cold weather, EAH 20 heats the incoming outdoor air slightly to prevent the condensation in ERS 20 from freezing to form ice.

The power of EAH 20 is selected taking into consideration the needs of the building, the choice of fuse, any building regulations, and the outdoor temperature at which the supply air fan in ERS 20 is permitted to start to slow down.

The energy saving increases the lower the power of the air heater that is selected. However, this increases the outdoor air flow that enters the house via leakage (instead of through ERS 20) at low outdoor temperatures.

### Choice of power on EAH 20

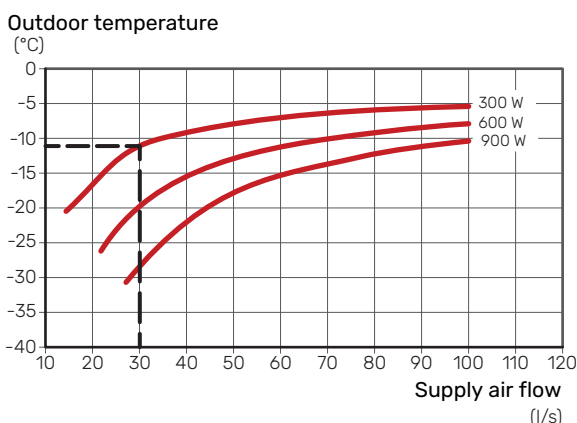

Example: In the case of a supply air flow of 30 l/s and a power of 300 W in the preheater, the supply air fan is permitted to start slowing down at an outdoor temperature of approx.  $-11^{\circ}\text{C}$ .

# Technical data

## Dimensions

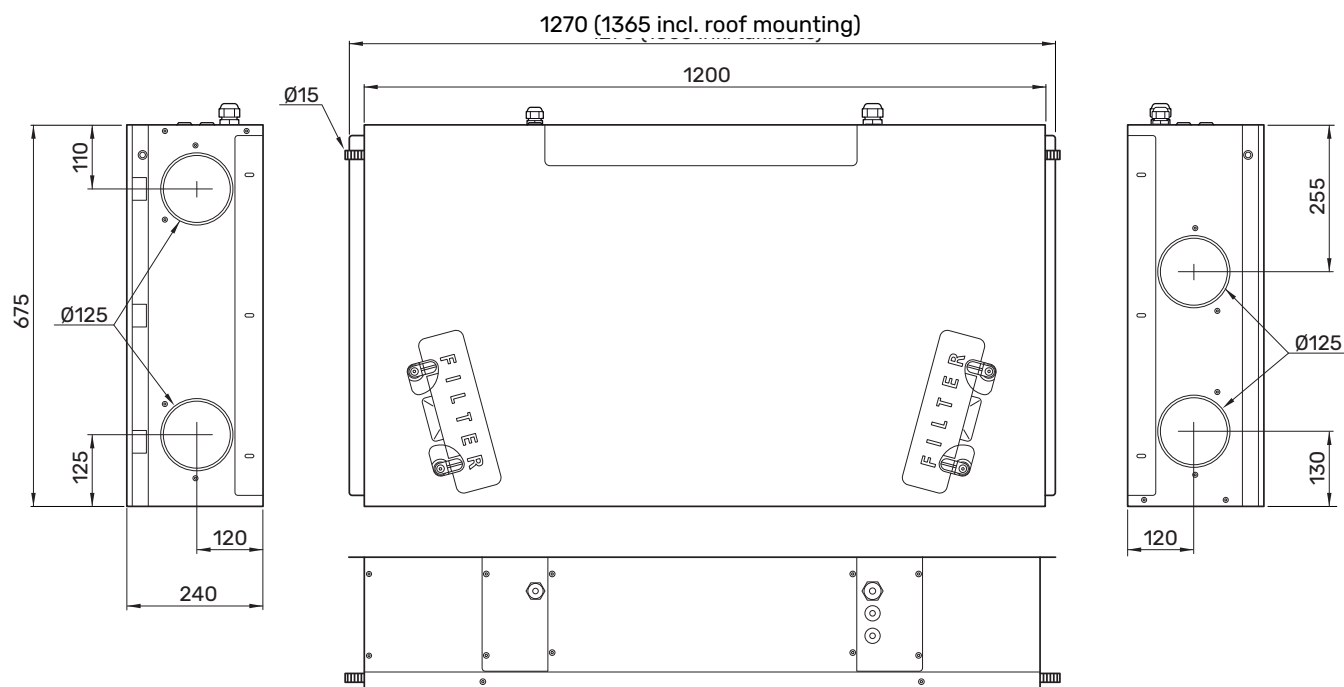

## Accessories

Not all accessories are available on all markets.

Detailed information about the accessories and complete accessories list available at [nibe.eu](http://nibe.eu).

### ELECTRICAL AIR HEATER EAH 20

In cold weather, EAH heats the incoming outdoor air slightly to prevent the condensation in ERS 20 from freezing to form ice. EAH should be used in houses where the outdoor temperature can be continuously lower than  $-5^{\circ}\text{C}$ .



### EAH 20-900

(300-900 W)

# Technical specifications

Type		ERS 20
<b>Electrical data</b>		
Supply voltage	V	230 V ~ 50Hz
Fuse	A	10
Driving power fan	W	2 x 85
Enclosure class		IP X1B
<b>Ventilation</b>		
Filter type, exhaust air filter		Coarse 65%
Filter type, supply air filter		ePM1 55%
<b>Noise</b>		
Sound power level ( $L_{W(A)}$ ) <sup>1</sup>	dB(A)	59
Sound pressure level ( $L_{P(A)}$ ) at 1 m <sup>2</sup>	dB(A)	41.1
Sound pressure level ( $L_{P(A)}$ ) at 1 m <sup>3</sup>	dB(A)	52.2
<b>Pipe connections</b>		
Ventilation $\emptyset$	mm	125
Condensation water drain $\emptyset$	mm	15
<b>Miscellaneous</b>		
Efficiency class <sup>4</sup>		A
Length, supply cable	m	2.4
Length, communication cable	m	2.0
Width	mm	1,200
Height	mm	240
Depth	mm	675
Weight	kg	25
Part No.		066 220

<sup>1</sup> 60 l/s (216 m<sup>3</sup>/h) at 50 Pa

<sup>2</sup> 35 l/s (126 m<sup>3</sup>/h) at 70 Pa

<sup>3</sup> 69 l/s (250 m<sup>3</sup>/h) at 150 Pa

<sup>4</sup> Scale for efficiency class: A+ to G.

## Dry temperature efficiency according to EN 308

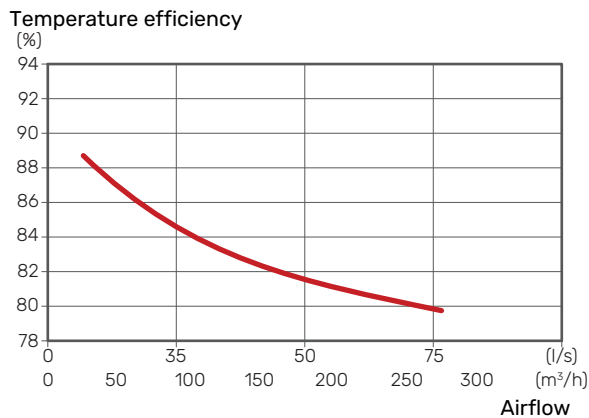

Outdoor air: 5 °C Exhaust air 25 °C RH exhaust air: <27.7 %

# Sustainable energy solutions since 1952

---

NIBE has been manufacturing energy-efficient and sustainable climate solutions for your home for 70 years. It all began in Markaryd, in the southern Swedish province of Småland, and we recognise our Nordic heritage by utilising the power of nature. We combine renewable energy with smart technology to offer efficient solutions, allowing us to work together to create a more sustainable future.

Regardless of whether it is a chilly winter's day or a warm afternoon in the summer sun, we need a balanced indoor climate that allows us to enjoy a comfortable life, whatever the weather. Our extensive range of products supply your home with cooling, heating, ventilation and hot water, making it possible for you to create a pleasant indoor climate with little impact on the environment.

NIBE Energy Systems  
Box 14, SE-285 21 Markaryd  
nibe.eu



---

This product sheet is a publication from NIBE Energy Systems. All product illustrations, facts and data are based on current information at the time of the publication's approval. NIBE Energy Systems makes reservations for any factual or printing errors in this product sheet.