

# Exhaust air heat pump

## **NIBE F470**

---



## Quick guide

### Navigation

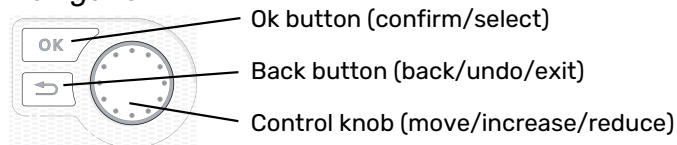

A detailed explanation of the button functions can be found on page 40.

How to scroll through menus and make different settings is described on page 42.

### Set the indoor climate

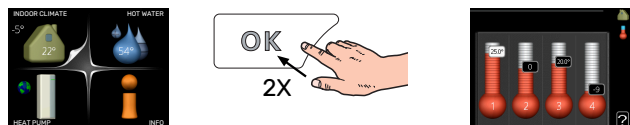

The mode for setting the indoor temperature is accessed by pressing the OK button twice, when in the start mode in the main menu.

### Increase hot water volume



To temporarily increase the amount of hot water, first turn the control knob to mark menu 2 (water droplet) and then press the OK button twice.

# Table of Contents

1	Important information	4	Start-up and inspection	32
	Safety information	4	Setting the heating curve	38
	Symbols	4		
	Marking	4	7 Control - Introduction	40
	Handling	4	Display unit	40
	Safety precautions	5	Menu system	40
	Serial number	9	8 Control - Menus	44
	Recovery	9	Menu 1 - INDOOR CLIMATE	44
	Inspection of the installation	10	Menu 2 - HOT WATER	44
2	Delivery and handling	11	Menu 3 - INFO	45
	Transport	11	Menu 4 - HEAT PUMP	45
	Assembly	11	Menu 5 - SERVICE	46
	Supplied components	12	9 Service	50
	Removing the covers	12	Maintenance	50
	Removing parts of the insulation	13	Service actions	50
3	The heat pump design	14	10 Disturbances in comfort	54
	General	14	Info menu	54
	Air treatment unit and compressor module	16	Manage alarm	54
			Troubleshooting	54
4	Pipe and ventilation connections	17	11 Accessories	56
	General pipe connections	17	12 Technical data	57
	Dimensions and pipe connections	18	Dimensions	57
	Symbol key	19	Technical specifications	58
	Climate system	19	Energy labelling	60
	Cold and hot water	19	Electrical circuit diagram	62
	Supply air battery	19	Item register	68
	Installation alternative	20	Contact information	71
	General ventilation connection	21		
	Ventilation flow	21		
	Adjusting ventilation	21		
	Dimensions and ventilation connections	22		
5	Electrical connections	23		
	General	23		
	Connections	25		
	Settings	27		
	Optional connections	27		
	Connecting accessories	30		
6	Commissioning and adjusting	31		
	Preparations	31		
	Filling and venting	31		

# Important information

## Safety information

This manual describes installation and service procedures for implementation by specialists.

The manual must be left with the customer.

For the latest version of the product's documentation, see [nibe.eu](http://nibe.eu).

This appliance can be used by children aged from 8 years and above and persons with reduced physical, sensory or mental capabilities or lack of experience and knowledge if they have been given supervision or instruction concerning use of the appliance in a safe way and understand the hazards involved. Children shall not play with the appliance. Cleaning and user maintenance shall not be made by children without supervision.

This is an original manual. It may not be translated without the approval of NIBE.

Rights to make any design or technical modifications are reserved.

©NIBE 2023.

Water may drip from the safety valve. A factory-fitted overflow pipe runs from the safety valve to an overflow cup. An overflow pipe has to be routed from the overflow cup to a suitable drain. The overflow pipe must be inclined along its entire length to prevent pockets where water can accumulate, and must be frost-proof.

F470 must be installed via an isolator switch. The cable area has to be dimensioned based on the fuse rating used.

## Symbols

Explanation of symbols that may be present in this manual.



### WARNING!

This symbol indicates serious danger to person or machine.



### NOTE

This symbol indicates danger to person or machine.



### Caution

This symbol indicates important information about what you should consider when installing or servicing the installation.



### TIP

This symbol indicates tips on how to facilitate using the product.

## Marking

Explanation of symbols that may be present on the product's label(s).



Fire hazard!



Read the User Manual.



Read the Installer Manual.

## Handling

The heat pump contains a highly flammable refrigerant. For this reason, take special care during handling, installation, service, cleaning and scrapping to prevent damage to the refrigerant system and thus reduce the risk of leakage.



### NOTE

Work on refrigerant systems must be carried out by personnel who have knowledge and experience of working with flammable refrigerants.

## Safety precautions



### WARNING!

Do not use agents to speed up the defrosting process or for cleaning, other than those recommended by the manufacturer.

The apparatus must be stored in a room with no continuous ignition sources (e.g. naked flame, an active gas installation or an active electric heater).

Must not be punctured or burned.

Be aware that the refrigerant may be odourless

### GENERAL

Pipe installation should be kept to a minimum.

### AREA CHECKS

Before work is started on systems that contains combustible refrigerants, safety checks must be performed to ensure that the ignition risk is kept to a minimum.

### WORKING METHOD

The work must be carried out in a controlled way to minimise the risk of contact with combustible gas or liquid during the work.

### GENERAL FOR THE WORKING RANGE

All maintenance staff and those who work in close proximity to the product must be instructed which type of work is to be carried out. Avoid carrying out work in enclosed spaces. The area surrounding the worksite must be cordoned off. Ensure that the area is made safe by removing combustible material.

### CHECK FOR THE PRESENCE OF REFRIGERANT

Check whether there is refrigerant in the area using a suitable refrigerant detector prior to and during work, to notify the service technician whether there is a possible flammable atmosphere or not. Ensure that the refrigerant detector is suitable for

combustible refrigerant, i.e. does not generate sparks or cause ignition in any other way.

### PRESENCE OF FIRE EXTINGUISHERS

If hot work is carried out on the heat pump, a powder or carbon dioxide fire extinguisher must be to hand.

### ABSENCE OF IGNITION SOURCES

Pipes connected to the unit must not contain potential sources of ignition.

Those who carry out work with refrigerant system connections, including exposing pipes that contain or have contained combustible refrigerant, may not use potential ignition sources in such a way that that can lead to risks of fire or explosions.

All potential ignition sources, including cigarette smoking, should be kept at a safe distance from the service work area where combustible refrigerant can leak out. Before carrying out work, the area surrounding the equipment must be checked to ensure that there are no ignition risks. "No smoking" signs must be displayed.

### VENTILATED AREA

Ensure that the work is carried out outdoors or that the work area is ventilated before the system is opened and before any hot work is carried out. The area must be ventilated whilst the work is being carried out. There must be ventilation around any refrigerant that comes out, which should be routed outdoors.

### CHECKING COOLING EQUIPMENT

If electrical components are replaced, the replacement parts must be fit for purpose and have the correct technical specifications. Always follow the manufacturer's guidelines regarding maintenance and servicing. Contact the manufacturer's technical department in the event of any doubts. The following checks must be carried out for installations that use combustible refrigerants.

- The actual filling quantity is appropriate for the magnitude of the space where the parts containing refrigerant are installed.
- Ventilation equipment and outlet work correctly and without obstructions.
- If an indirect refrigerant circuit is used, check whether the secondary circuit contains refrigerant.
- All markings of equipment are visible and clear. Markings, signs and similar that are not clear must be replaced.
- Refrigerant pipes and components are positioned in such a way that it is not likely that they be subjected to substances that can corrode components containing refrigerant, if these components are not made of material that is resistant against corrosion, or not appropriately protected against such corrosion.

### **CHECKING ELECTRICAL EQUIPMENT**

Repair and maintenance of electrical components must include initial safety checks and procedures for component inspection. In the event of a fault, which can cause a safety risk, do not supply any power to the circuit until the fault has been rectified. If the fault cannot be rectified immediately, and operation must continue, an adequate temporary solution must be implemented. This must be reported to the equipment owner, so that all parties have been informed.

The following checks must be carried out at the initial safety checks.

- That the capacitors are discharged. Discharging must be done safely, to prevent the risk of sparking.
- That no powered electrical components or live cables are exposed when filling or collecting refrigerant or when the system is flushed.
- That the system is continually earthed.

### **REPAIRING SEALED COMPONENTS**

When repairing sealed components, all electrical supply must be disconnected from the equipment that is being repaired

before any sealed covers or similar are removed. If it is absolutely necessary to have an electricity supply to the equipment during the service, continuously activated leak tracing must be performed at the most critical points in order to warn of any dangerous situations.

Pay particular attention to the following so that the sheath is not changed in a way that affects the protection level when working with electrical components. This means damage to cables, unnecessary amounts of connections, terminals that do not follow the original specifications, damaged gas-kets, incorrect grommets etc.

Ensure that the apparatus is secured properly.

Check that seals or sealing materials have not deteriorated to a degree that they can no longer prevent combustible gases from entering. Replacement parts must meet the manufacturer's specifications.



#### **NOTE**

Use of silicone seals can hamper the efficiency of certain types of leak-tracing equipment. Components with built in safety do not need to be isolated before starting work.

### **WIRING**

Check that cabling will not be subject to wear, corrosion, excessive pressure, vibration, sharp edges or any other adverse environmental effects. The check shall also take into account the effects of aging or continual vibration from sources such as compressors or fans.

### **LEAK TESTING**

The following leak detection methods are deemed acceptable for systems containing flammable refrigerants.

Electronic leak tracers must be used to detect combustible refrigerant; but the leak tracer may not be sufficiently sensitive or may need to be recalibrated (the leak tracing equipment must be calibrated in an area completely free from refrigerant). The

leak tracer must not be a potential source of ignition and must be suitable for the relevant refrigerant. The leak tracing equipment must be set and calibrated for the relevant refrigerant, to ensure that the gas concentration is a maximum of 25% of the lowest combustible concentration (Lower Flammability Limit, LFL) of the relevant refrigerant.

Leak detection fluids are suitable for use with most refrigerants but the use of detergents containing chlorine shall be avoided as the chlorine may react with the refrigerant and corrode the copper pipe-work.

If a leak is suspected, all naked flames shall be removed/extinguished.

If a leak that requires brazing is detected, all refrigerant must be removed from the system and stored in a separate container. Alternatively, the refrigerant can be stored separated from the brazing area in a part of the system at a safe distance from the leak, if this part of the system can be disconnected safely with shut-off valves. The system must be emptied in accordance with the section "Removal and draining".

### **REMOVAL AND DRAINING**

When a cooling circuit is opened for repairs – or for another reason – work must be carried out in a conventional manner. Due to the risk of fire it is important that best practice is applied. Follow the procedure below.

1. Remove the refrigerant
2. Flush the circuit with inert gas.
3. Drain the circuit.
4. Flush through with inert gas.
5. Open the circuit by cutting or brazing.

Collect the refrigerant in the intended cylinders. Clean the system with oxygen-free nitrogen to make the unit safe. This process may need to be repeated several times. Compressed air and oxygen must not be used.

Clean the system by breaking the vacuum with oxygen-free nitrogen, and filling the system to working pressure, relieving the pressure to atmospheric pressure and finally pumping to vacuum. Repeat the process until no refrigerant remains in the system. After the final filling with oxygen-free nitrogen, relieve the pressure in the system to atmospheric pressure, so that work can be carried out. This type of flushing must always be carried out if hot work is to be performed on the pipe system.

Ensure that the vacuum pump's outlet is not near to any potential ignition sources and that there is satisfactory ventilation by the outlet.

### **FILLING**

In addition to the conventional filling procedures, the following actions must be taken.

- Ensure that different refrigerants are not mixed when filling equipment is used. Hoses and lines must be as short as possible to minimise the enclosed refrigerant volume.
- Containers must be stored in a suitable position in accordance with the instructions.
- Ensure that the cooling system is grounded before the system is filled with refrigerant.
- Mark the system once filling is complete (if not already marked). If the amount differs from the pre-installed amount, the marking must include the pre-installed amount, the added extra amount and the total amount.
- Take extra care not to overfill the cooling system.

Before refilling the system, pressure test it with oxygen-free nitrogen. Leak test the system after filling but before using the system. Perform an additional leak test before leaving the installation.

## DECOMMISSIONING

Before the device is taken out of operation, the technician must without exception be very familiar with the equipment and all its component parts. Good practice prescribes that all refrigerant is collected safely. Before the collected refrigerant can be reused, oil and refrigerant samples must be taken, if analysis is required. There must be a power supply when this task is started.

1. Familiarise yourself with the equipment and its use.
2. Isolate the system electrically.
3. Before starting the procedure, ensure that:
  - necessary equipment for mechanical handling of the refrigerant container is available
  - all necessary personal safety equipment is available and used correctly
  - the collection process is continuously supervised by an authorised person
  - the collection equipment and containers meet appropriate standards.
4. Pump the refrigerant system to vacuum, if possible.
5. If it is not possible to pump to vacuum, manufacture a branch, so that the refrigerant can be retrieved from different parts of the system.
6. Check that the refrigerant container is on the scales before starting to collect.
7. Start the collection device and collect according to the manufacturer's instructions.
8. Do not overfill the containers (max. 80 % (volume) liquid content).
9. Do not exceed the containers' maximum permitted working pressure – not even temporarily.
10. When the containers have been filled correctly and the process is complete, close all shut-off valves in the equip-

ment and remove and containers and equipment from the installation immediately.

11. The collected refrigerant must not be filled in any other system before being cleaned and checked.

## Marking

The equipment must be marked stating that it has been taken out of operation and drained of refrigerant. The marking must be dated and signed. Check that the equipment is marked indicating that it contains combustible refrigerant.

## Collection

Best practice prescribes that all refrigerant is collected safely when the refrigerant is drained from a system, either for servicing or for decommissioning.

The refrigerant must only be collected in suitable refrigerant containers. Ensure that the required number of containers, which can hold the entire volume of the system, are available. All containers that are to be used must be intended for the collection of the refrigerant and marked for this refrigerant (specifically designed for the collection of refrigerant). The containers have to be equipped with correctly functioning pressure relief valves and shut-off valves. Empty collection containers must be drained and, if possible, chilled before collection.

The collection equipment must function correctly and instructions for the equipment must be to hand. The equipment must be suitable for the collection of combustible refrigerant.

Fully functioning and calibrated scales must also be to hand.

Hoses must be in good condition and be equipped with leak-proof quick couplings. Before using the collecting machine, check that it is working correctly and has been properly maintained. Associated electrical components must be sealed, to prevent ig-



dition if any refrigerant should leak out. Contact the manufacturer if you are in any doubt.

Return the collected refrigerant to the refrigerant supplier in the correct collection container and with the relevant Waste Transfer Note. Do not mix refrigerants in collection devices or containers.

If compressors/compressor oil are/is to be removed ensure that the affected device is drained to an acceptable level to ensure that no combustible refrigerant remains in the lubricant. Compressors must be drained before being returned to the supplier. Only electrical heating of the compressor housing may be used to quicken draining. Drain oil from the system in a safe manner.

## MISCELLANEOUS

Maximum amount of refrigerant: See Technical Specifications in the Installer Manual.

- Everyone who works with or opens a refrigerant circuit must have a current, valid certificate from an accredited industry issuing body, which states that, according to the industry's recognised assessment standard, they have the authority to safely handle refrigerants.
- Servicing must only be performed according to the equipment manufacturer's recommendations.

Maintenance and repairs that require the assistance of another trained person must be carried out under the supervision of person with the authority to handle combustible refrigerants.

Maintenance and repair that requires the skill of another person must be carried out under the supervision of someone with the above expertise.

## Serial number

The serial number can be found at the bottom right of the front cover, in the info menu (menu 3.1) and on the type plate (PZ1).

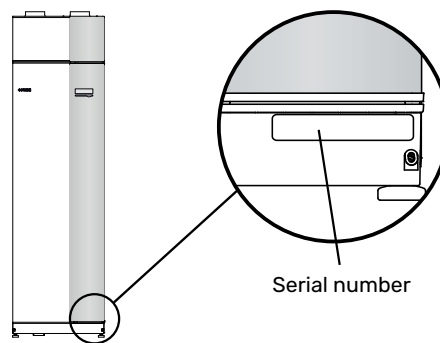

### Caution

You need the product's (14 digit) serial number for servicing and support.

## Recovery



Leave the disposal of the packaging to the installer who installed the product or to special waste stations.

Do not dispose of used products with normal household waste. It must be disposed of at a special waste station or dealer who provides this type of service.

Improper disposal of the product by the user results in administrative penalties in accordance with current legislation.

## Inspection of the installation

Current regulations require the heating installation to undergo an installation inspection before it is commissioned. The inspection must be carried out by a suitably qualified person. In addition, fill in the page for information regarding the installation data in the User Manual.

✓	Description	Notes	Signature	Date
	Ventilation (page 21)			
	Setting ventilation flow exhaust air			
	Setting ventilation flow supply air			
	Connecting ground cables			
	Heating medium (page 19)			
	System flushed			
	System vented			
	Circulation pump setting			
	Pressure in the climate system			
	Setting trim valve, number of turns from closed position			
	Electricity (page 23)			
	Connections			
	Main voltage			
	Phase voltage			
	Fuses heat pump			
	Fuses property			
	Outside sensor			
	Room sensor			
	Current sensor			
	Safety breaker			
	Earth circuit-breaker			

# Delivery and handling

## Transport

F470 should be transported and stored vertically in a dry place.

Ensure that the heat pump cannot fall over during transport.

Check that F470 has not been damaged during transport.

However, the F470 can be carefully laid on its back when being moved into the building.

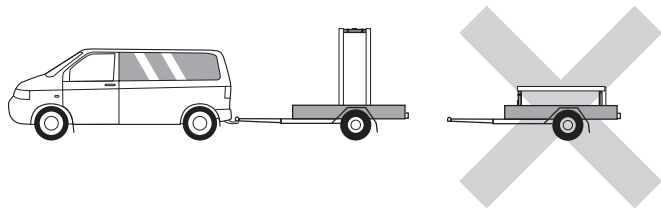

## Assembly

- Position F470 on a solid foundation indoors that withstands water and the weight of the product.
- Use the product's adjustable feet to attain a horizontal and stable set-up.

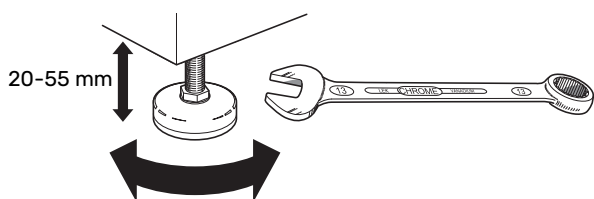

- Since water comes from F470, the area where F470 is located must be equipped with floor drainage.
- Because water comes from F470, the floor coating is important. A waterproof floor or floor membrane is recommended.
- Install with its back to an outside wall, ideally in a room where noise does not matter, in order to eliminate noise problems. If this is not possible, avoid placing it against a wall behind a bedroom or other room where noise may be a problem.
- Wherever the unit is located, walls to sound sensitive rooms should be fitted with sound insulation.
- Route pipes so they are not fixed to an internal wall that backs on to a bedroom or living room.
- The installation area always has to have a temperature of at least 10 °C and max. 30 °C.

## INSTALLATION AREA

Leave a free space of 800 mm in front of the product. Leave free space between F470 and wall/other machinery/fittings/cables/pipes etc. It is recommended that a space of at least 10 mm is left to reduce the risk of noise and of any vibrations being propagated.

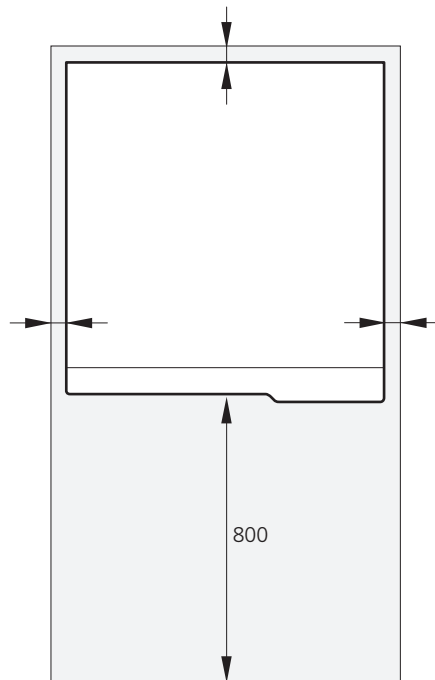

### NOTE

Ensure that there is sufficient space (300 mm) above F470 for connecting ventilation ducts.

## Supplied components



Outdoor temperature sensor  
(BT1)



Room sensor(BT50)

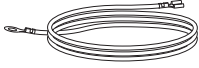

Earth cabling (4 pcs)



Current sensor

### LOCATION

The kit of supplied items is placed on top of the product.

## Removing the covers

### FRONT COVER

1. Remove the upper panel by pulling it straight out.
2. Remove the screws from the lower edge of the front panel.

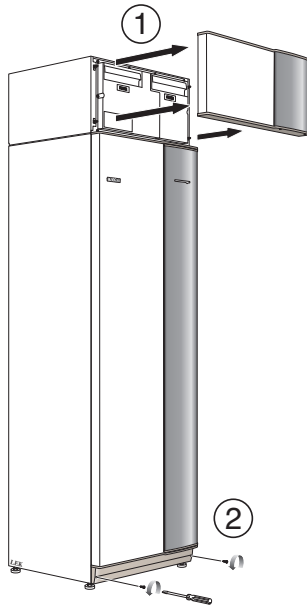

3. Lift the panel out at the bottom edge and up.

4. Pull the panel towards yourself.

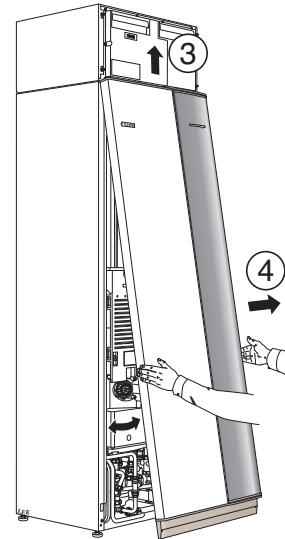

### SIDE PANELS

1. Remove the screws from the upper and lower edges.

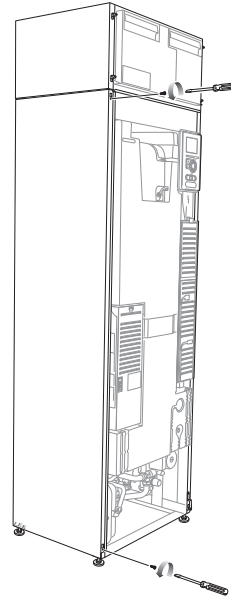

2. Twist the panel slightly outwards.

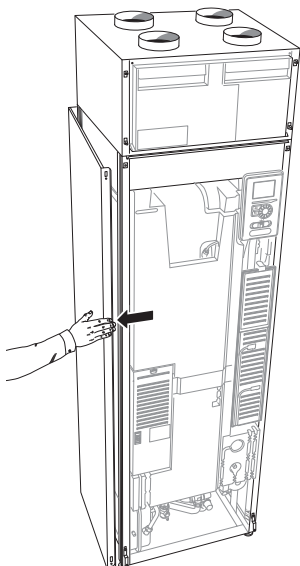

## INSULATION, TOP

Grip the handle and pull straight out as illustrated.

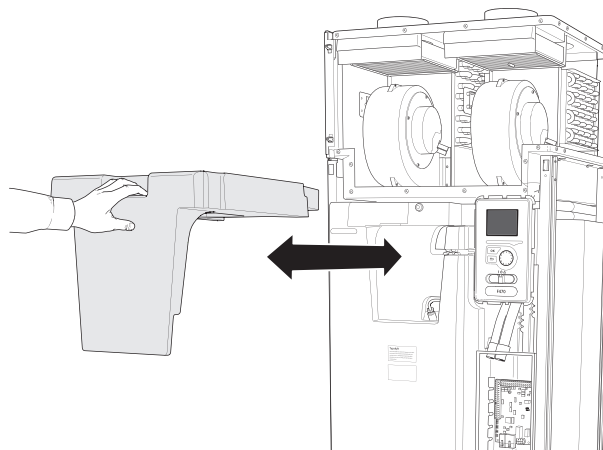

3. Move the panel backwards and slightly to the side.

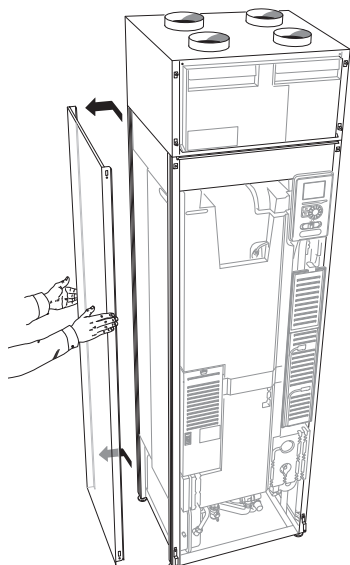

4. Assembly takes place in the reverse order.

## Removing parts of the insulation

Parts of the insulation can be removed to facilitate the installation.

# The heat pump design

## General

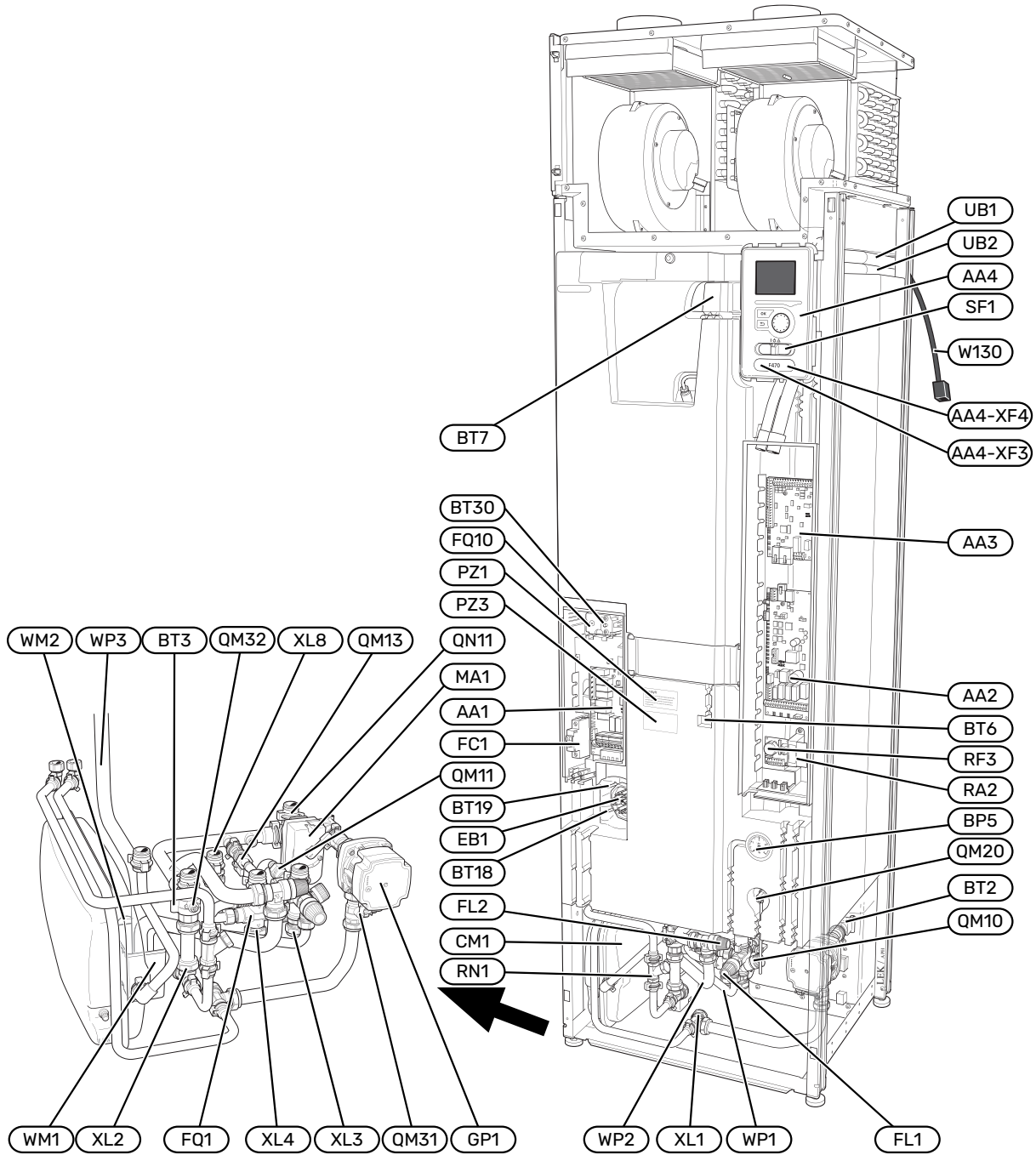

## PIPE CONNECTIONS

XL1	Connection, heating medium flow line
XL2	Connection, heating medium return line
XL3	Connection, cold water
XL4	Connection, hot water
XL8	Connection, docking in

## HVAC COMPONENTS

CM1	Expansion vessel
FL1	Safety valve, water heater
FL2	Safety valve, climate system
FQ1	Mixer valve, hot water
GP1	Circulation pump
QM10	Filler valve, hot water heater
QM11	Filler valve, climate system
QM13	Filler valve 2, climate system
QM20	Vent valve, heating medium
QM31	Shut-off valve, heating medium flow
QM32	Shut off valve, heating medium return
QN11	Shunt valve
RN1	Trim valve
WM1	Overflow cup
WM2	Overflow water discharge
WP1	Overflow pipe, safety valve hot water heater
WP2	Overflow pipe, safety valve climate system
WP3	Overflow pipe, condensation

## SENSORS ETC.

BP5	Pressure gauge, heating system
BT2	Temperature sensors, heating medium flow
BT3	Temperature sensors, heating medium return
BT6	Controlling hot water sensor
BT7	Display hot water sensor
BT18	Temperature sensor, compressor operation
BT19	Temperature sensor, immersion heater operation
BT30	Thermostat, backup heating

## ELECTRICAL COMPONENTS

AA1	Immersion heater card
AA2	Base card
AA3	Input circuit board
AA4	Display unit
	AA4-XF3 USB port
	AA4-XF4 Service socket
EB1	Immersion heater
FC1	Miniature circuit-breaker
FQ10	Temperature limiter
MA1	Shunt motor with hand wheel
RA2	Choke
RF3	EMC card
SF1	Switch
W130	Network cable for NIBE Uplink

## MISCELLANEOUS

PZ1	Rating plate
PZ3	Serial number plate
UB1-2	Cable gland

Designations according to standard EN 81346-2.

# Air treatment unit and compressor module

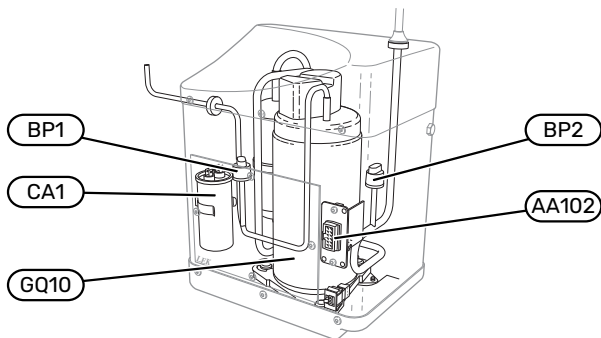
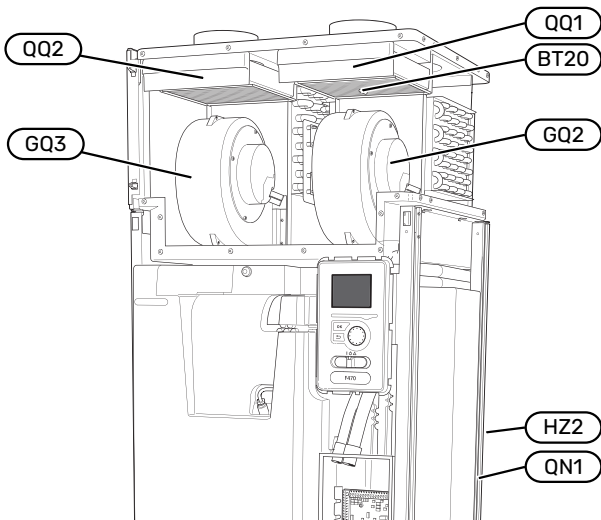
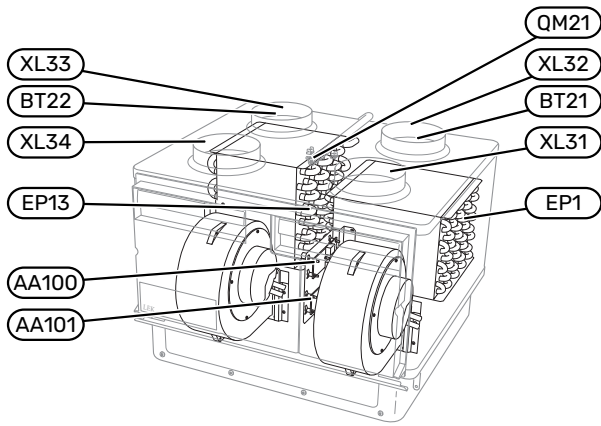

## VENTILATION CONNECTIONS

- XL31 Ventilation connection, supply air
- XL32 Ventilation connection, extract air
- XL33 Ventilation connection, exhaust air
- XL34 Ventilation connection, outdoor air

## HVAC COMPONENTS

- EP13 Supply air battery
- QM21 Vent valve, supply air coil

## SENSORS ETC.

- BP1 High pressure pressostat
- BP2 Low pressure pressostat
- BT16 Temperature sensor, evaporator<sup>1</sup>
- BT20 Temperature sensor, exhaust air
- BT21 Temperature sensor, extract air
- BT22 Temperature sensor, supply air

<sup>1</sup> Not visible in the image

## ELECTRICAL COMPONENTS

- AA100 Connection card air treatment section, exhaust air
- AA101 Connection card air treatment section, supply air
- AA102 Connection card compressor card
- CA1 Capacitor

## COOLING COMPONENTS

- EP1 Evaporator
- GQ10 Compressor
- HZ2 Drying filter<sup>1</sup>
- QN1 Expansion valve<sup>1</sup>

<sup>1</sup> Located on the back of the product

## VENTILATION

- GQ2 Exhaust air fan
- GQ3 Supply air fan
- HQ10 Exhaust air filter<sup>1</sup>
- HQ11 Supply air filter<sup>1</sup>
- QQ1 Filter cover, exhaust air
- QQ2 Filter cover, supply air

<sup>1</sup> Not visible in the image



# Pipe and ventilation connections

## General pipe connections

Pipe installation must be carried out in accordance with current norms and directives.

The system requires the radiator circuit to be designed for a low temperature heating medium. At the lowest dimensioned outdoor temperature (DOT) the highest recommended temperatures are 55 °C on the supply line and 45 °C on the return line.



### Caution

Ensure that incoming water is clean. When using a private well, it may be necessary to supplement with an extra water filter.



### NOTE

The pipe systems have to be flushed clean before the product is connected, to prevent any contaminants from damaging the components.



### NOTE

Water may drip from the safety valve. A factory-fitted overflow pipe runs from the safety valve to an overflow cup. An overflow pipe has to be routed from the overflow cup to a suitable drain. The overflow pipe must be inclined along its entire length to prevent pockets where water can accumulate, and must be frost-proof.

## SYSTEM VOLUME

F470 is equipped with an expansion vessel (CM1).

The volume of the expansion vessel is 10 litres and it is pre-pressurised as standard to 0.5 bar. As a result, the maximum permitted height "H" between the expansion vessel and the highest installed radiator is 5 m, see figure.

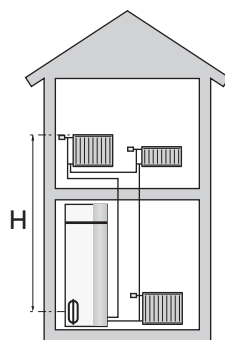

If the pre-pressure is not high enough, it can be increased by filling with air via the valve in the expansion vessel. Any change in the pre-pressure affects the ability of the expansion vessel to handle the expansion of the water.

The maximum system volume, excluding F470, is 219 litres at the above-mentioned pre-pressure.

## SYSTEM DIAGRAM

F470 consists of a heat pump, water heater, immersion heater, fans, circulation pump and control system. F470 is connected to the ventilation system and heating medium circuit.

When the exhaust air at room temperature passes through the evaporator, the refrigerant evaporates because of its low boiling point. As a result, the air releases energy to the refrigerant.

The refrigerant is then compressed in a compressor, causing the temperature to rise considerably.

The warm refrigerant is led to the condenser. Here the refrigerant gives off its energy to the heating system water, whereupon the refrigerant changes state from gas to liquid.

The refrigerant then goes via filters to the expansion valve, where the pressure and temperature are reduced.

The refrigerant has now completed its circulation and returns to the evaporator.

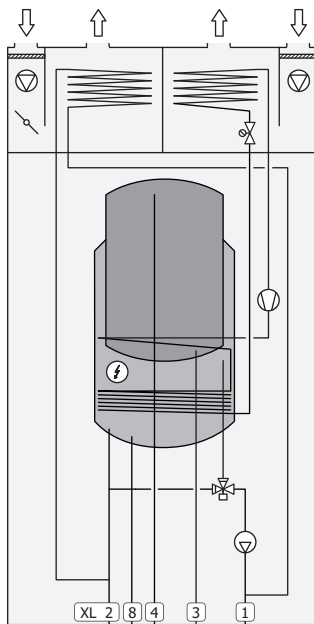

### Pipe connections

XL1	Connection, heating medium flow line
XL2	Connection, heating medium return line
XL3	Connection, cold water
XL4	Connection, hot water
XL8	Connection, docking in



### Caution

This is a principle of operation. For more detailed information about F470, see section "The heat pump design".

## Dimensions and pipe connections

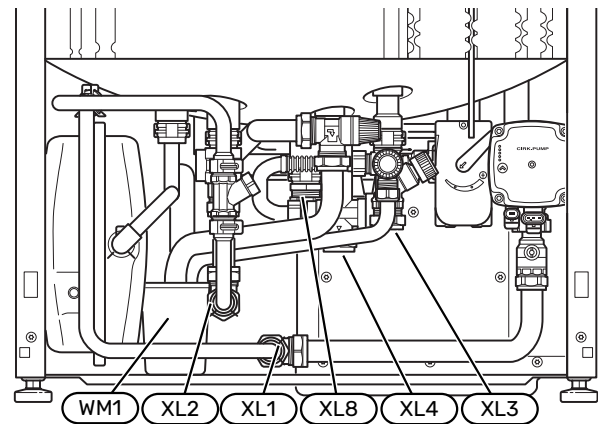

The overflow cup (WM1) can be turned, allowing the pipe to be pointed forwards or backwards to simplify connection to the drain.

### SETTING OUT DIMENSIONS

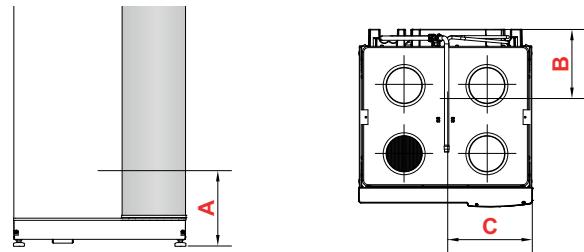

















Connection		A	B	C
XL1 Heating medium supply	(mm)	45	420	335
XL2 Heating medium return	(mm)	95	415	380
XL3 Cold water	(mm)	200	455	215
XL4 Hot water	(mm)	180	405	265
XL8 Docking	(mm)	220	290	300
WM1 Overflow cup	(mm)	95	205	435

### PIPE DIMENSIONS

Connection		
XL1-XL2 Heating medium ext $\theta$	(mm)	22
XL3 Cold water ext $\theta$	(mm)	22
XL4 Hot water ext $\theta$	(mm)	22
XL8 Docking ext. $\theta$	(mm)	22
WM2 Overflow water discharge	(mm)	32

## Symbol key

Symbol	Meaning
	Unit box
	Non-return valve
	Mixing valve
	Circulation pump
	Immersion heater
	Expansion valve
	Fan
	Compressor
	Temperature sensor
	Trim valve
	Reversing valve/shunt
	Overflow valve
	Domestic hot water
	Hot water circulation
	Heat pump
	Heating system
	Heating system with lower temperature

## Climate system

A climate system is a system that regulates the indoor temperature with the help of the control system in F470 and, for example, radiators, underfloor heating, fan coils, etc.

### CONNECTING THE CLIMATE SYSTEM

Install as follows:

- When connecting to a system with thermostats, either a bypass valve must be fitted or, alternatively, some of the thermostats must be removed to ensure there is sufficient flow and heat emission.

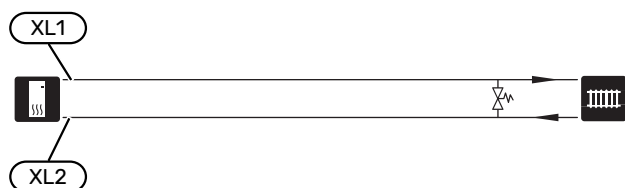

## Cold and hot water

The settings for hot water are made in menu 5.1.1.

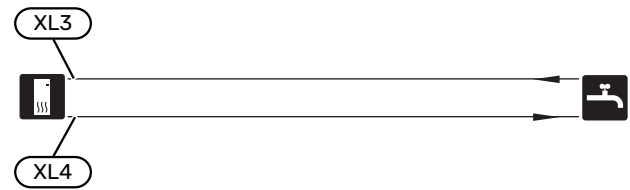

## Supply air battery

The supply air battery (EP13) is connected in parallel with the radiator circuit and heats the house's supply air. The water flow through the supply air battery is set using a trim valve (RN1). The supply air temperature has to be roughly the same as the indoor temperature, preferably a degree or so lower.



### TIP

If possible, choose a cold day to adjust the trim valve.

## Installation alternative

F470 can be installed in several different ways, some of which are shown here.

Further option information is available at [nibe.eu](http://nibe.eu) and in the respective assembly instructions for the accessories used. See page 56 for a list of the accessories that can be used with F470.

### EXTRA HOT WATER HEATERS

The system should be supplemented with an extra water heater, if a large bath tub or other significant consumer of hot water is installed.

### Water heater with immersion heater

If there is the option to use a water heater with an immersion heater, NIBE COMPACT or NIBE EMINENT type water heaters can be used.

In a water heater with an immersion heater, the water is initially heated by the heat pump. The immersion heater in the water heater is used for keeping warm and when the heat pump does not have sufficient power.

The water heater's flow is connected after F470.

If the valve connector is to be installed externally, moved out or separated, it must be replaced with a separable connector  $\varnothing$  22 mm.

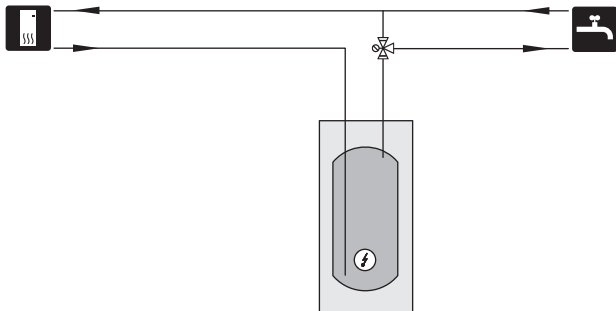

### HOT WATER CIRCULATION

A circulation pump can be controlled by F470 to circulate the hot water. The circulating water must have a temperature that prevents bacterial growth and scalding, and national standards must be satisfied.

The HWC return is connected to a freestanding water heater.

The circulation pump is activated via the AUX output in menu 5.4 - "soft in/outputs".

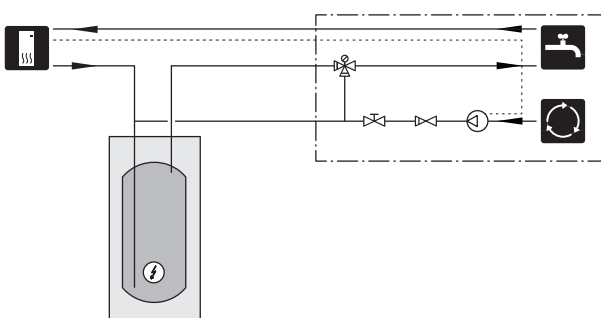

### EXTRA CLIMATE SYSTEM

In buildings with several climate systems that require different supply temperatures, the accessory ECS 40/ECS 41 can be connected.

ECS 40/ECS 41 is connected to connection, docking in (XL8).

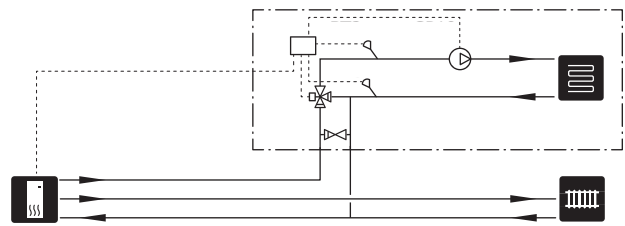

## General ventilation connection

- Ventilation installation must be carried out in accordance with current norms and directives.
- Connections must be made via flexible hoses, which should be installed so that they are easy to replace.
- Provision must be made for inspection and cleaning of the duct.
- Make sure that there are no reductions of cross-sectional area in the form of creases, tight bends, etc., since this will reduce the ventilation capacity.
- The air duct system must be a minimum of air tightness class B.
- To prevent fan noise being transferred to the ventilation devices, install silencers in suitable locations in the duct system.
- The extract air and outdoor air ducts are insulated using diffusion-proof material along their entire lengths.
- Ensure that the condensation insulation is fully sealed at any joints and/or at lead-in nipples, silencers, roof cowls or similar.
- The air must be routed to the outdoor air duct through an outer wall grille in the facade. The outer wall grille must be installed so that it is protected from the weather and must be designed so that no rainwater and/or snow can penetrate the facade or follow the air into the duct.
- When positioning the outdoor air and extract air hood/grille, bear in mind that the two air flows must not short circuit to prevent the extract air from being drawn into F470 again.
- The extract air duct must be a maximum of 20 m long with a maximum of six bends.
- Because the heat pump contains a flammable refrigerant, the air ducting system must be earthed. This is done by making a good electrical connection to the air ducts using the enclosed earth cables (4). The cables must then be connected to the earth pins on top of the top cover.
- A duct in a masonry chimney stack must not be used for extract air or outdoor air.
- When external devices that affect the ventilation are used, for example kitchen fans and stoves, the heat pump must be in operation. There is a risk of freezing at low outdoor temperatures.



### NOTE

An external frost protection damper (QN42) must be installed in the outdoor air duct.

- The frost protection damper (QN42) must be dimensioned to seal against the negative pressure that can be created in the house, for example when a fire is lit in the stove

when the supply air fan and heat pump are switched off. An external supply air duct to e.g. the stove is recommended.

## EXHAUST AIR DUCT /KITCHEN FAN

Exhaust air duct (kitchen fan) must not be connected to F470.

To prevent cooking odours from being led to the F470, the distance between the kitchen fan and the exhaust air valve must be taken into consideration. The distance must not be less than 1.5 m, but may vary between different installations.

Always use a kitchen fan when cooking.

## Ventilation flow

Connect F470 so that all the exhaust air, except kitchen duct air (kitchen fan), passes through the evaporator (EP1) in the heat pump.

The ventilation flow must comply with the applicable national standards.

For optimum heat pump performance, the ventilation flow must not be less than 28 l/s (100 m<sup>3</sup>/h) at an exhaust air temperature of at least 20 °C. When the exhaust air temperature is lower than 20 °C (for example at start-up and when there is nobody at home), the minimum value is 31 l/s (110 m<sup>3</sup>/h).

The supply air flow must be lower than the exhaust air flow to prevent over pressure in the house.

The heat pump's installation area must be ventilated to at least 5 l/s (18 m<sup>3</sup>/h)

Set the ventilation capacity in the heat pump's menu system (menu 5.1.5 - "fan sp. exhaust air").

If the exhaust air temperature falls below 16 °C, the compressor is blocked and electric additional heat is permitted. No energy is recovered from the exhaust air when the compressor is blocked.

## Adjusting ventilation

To obtain the necessary air exchange in every room of the house, the exhaust air device and the supply air device must be correctly positioned and adjusted and the fans in the heat pump adjusted.

Immediately after installation adjust the ventilation so that it is set according to the projected value of the house.

Incorrect adjustment of the ventilation may lead to reduced installation efficiency and thus poorer operating economy, a poorer indoor climate and moisture damage in the building.

## Dimensions and ventilation connections

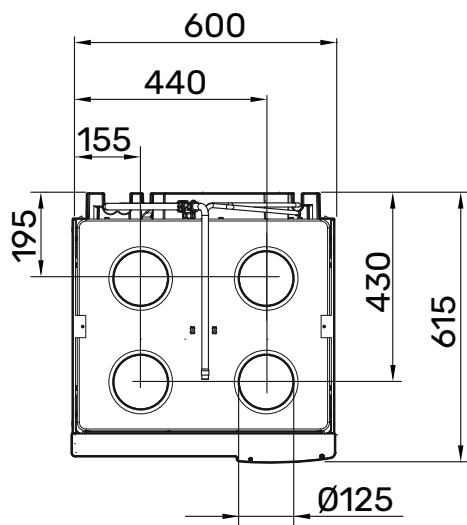
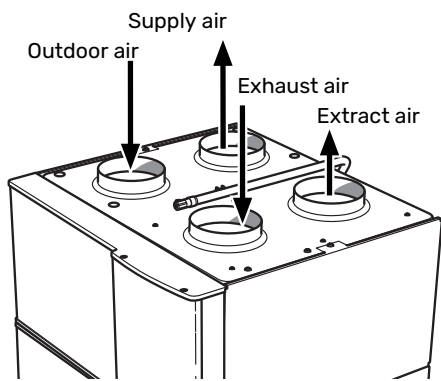

# Electrical connections

## General

All electrical equipment, except the outdoor sensors, room sensors and the current sensors are ready connected at the factory.

- Electrical installation and wiring must be carried out in accordance with national provisions.
- Disconnect F470 before insulation testing the house wiring.
- F470 must be fitted with a residual current device. If the property is equipped with a residual current device, F470 must be equipped with a separate one.
- F470 must be installed via an isolator switch. The cable area has to be dimensioned based on the fuse rating used.
- If a miniature circuit breaker is used, this must have at least triggering characteristic "C". See section "Technical specifications" for fuse size.
- To prevent interference, communication cables to external connections must not be laid in the vicinity of high voltage cables.
- The minimum area of communication and sensor cables to external connections must be 0.5 mm<sup>2</sup> up to 50 m, for example EKKX, LiYY or equivalent.
- For an electrical wiring diagram for F470, see the "Technical specifications" section.
- When routing a cable into F470, the cable grommets (UB1) and (UB2) must be used.

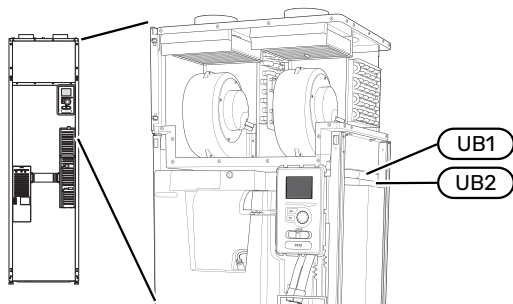

### NOTE

Electrical installation and any servicing must be carried out under the supervision of a qualified electrician. Disconnect the current using the circuit breaker before carrying out any servicing.

### NOTE

If the supply cable is damaged, only NIBE, its service representative or similar authorised person may replace it to prevent any danger and damage.



### NOTE

Check the connections, main voltage and phase voltage before the product is started, to prevent damage to the heat pump electronics.



### NOTE

Do not start the system before filling up with water. Components in the system could be damaged.

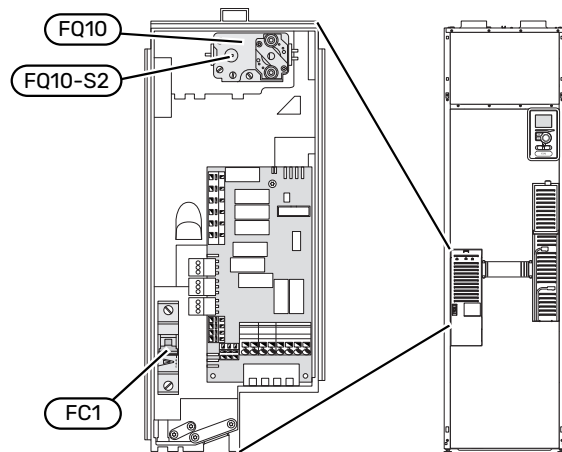

### MINIATURE CIRCUIT-BREAKER (FC1)

Operation (230 V), fans, compressor, circulation pump, etc., are internally fused by a miniature circuit breaker (FC1).



### Caution

Check the miniature circuit-breaker (FC1). It may have tripped during transport.

### TEMPERATURE LIMITER (FQ10)

The temperature limiter (FQ10) cuts the current supply to the electric additional heat if the temperature rises between 90 and 100°C and can be manually reset.

### Resetting

The temperature limiter (FQ10) is accessible behind the front cover. Reset the temperature limiter by carefully pressing the button (FQ10-SF2) using a small screwdriver.

### ACCESSIBILITY, ELECTRICAL CONNECTION

The plastic cap of the electrical boxes is opened using a screwdriver.



### NOTE

The cover for the input card is opened without a tool.

## Removing the cover, input board

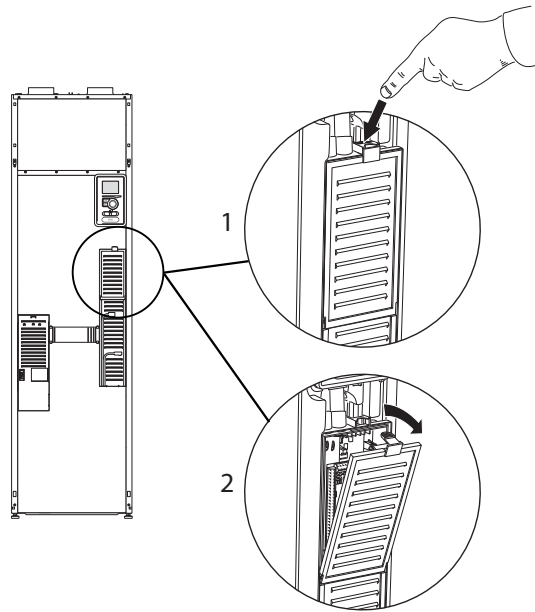

1. Push the catch down.
2. Angle out the cover and remove it.

## Removing the cover, immersion heater board

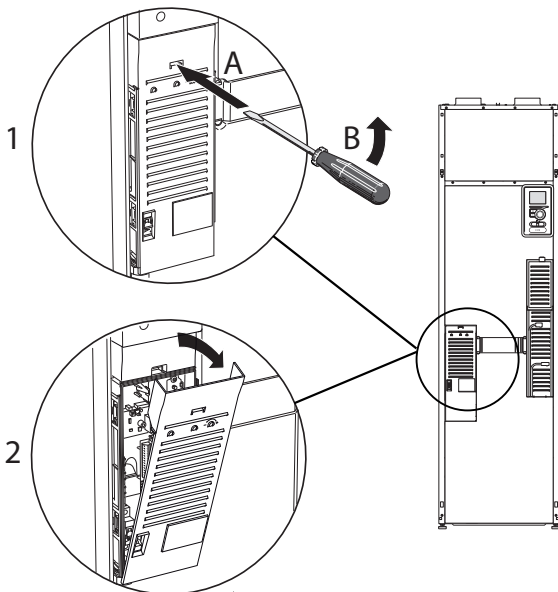

1. Insert the screwdriver (A) and pry the catch carefully downwards (B).
2. Angle out the cover and remove it.

## Removing the cover, base circuit board



### Caution

To remove the cover for the base board, the cover for the input circuit board must first be removed.

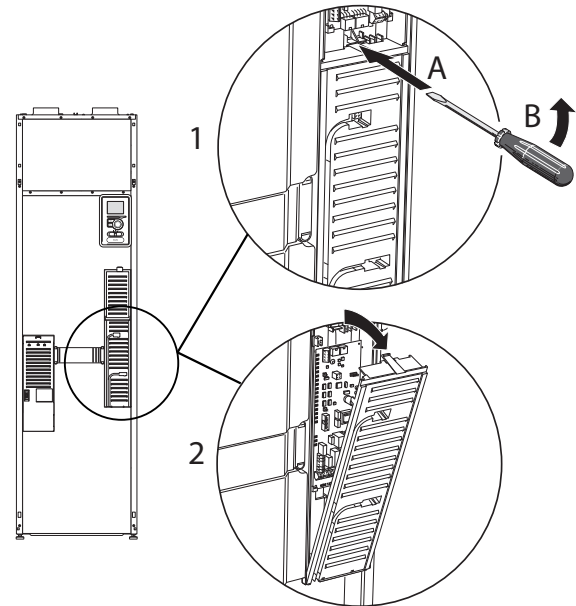

1. Insert the screwdriver (A) and pry the catch carefully downwards (B).
2. Angle out the cover and remove it.

## CABLE LOCK

Use a suitable tool to release/lock cables in the heat pump terminal blocks.

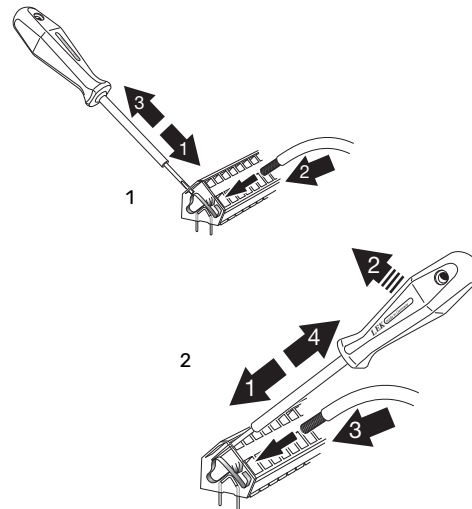



# Connections

## POWER CONNECTION

F470 must be installed via an isolator switch. The cable area has to be dimensioned based on the fuse rating used.

The enclosed cable (length approx. 2 m) for the incoming supply electricity is connected to terminal block X1 on the electric addition PCB (AA1).

The connection cable can be found on the reverse of F470 (see dimensions diagram below).

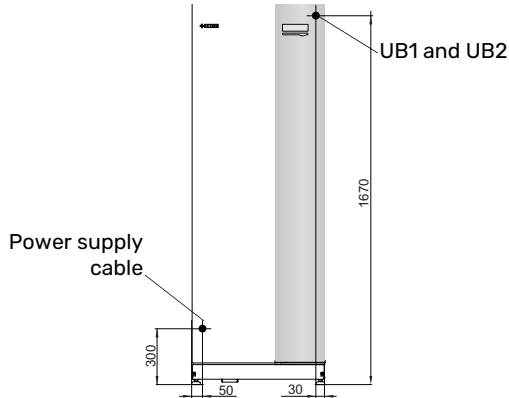

## Connection 3x400V

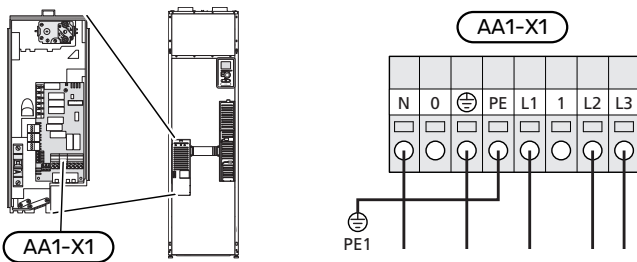

If a separate supply to the compressor and immersion heater is required, see section "Possible selection for AUX inputs" on page 29.

## TARIFF CONTROL

If the voltage to the immersion heater and/or the compressor disappears for a certain period, there must also be blocking via the AUX-input at the same time, see "Possible selection for AUX inputs".

## CONNECTING EXTERNAL OPERATING VOLTAGE FOR THE CONTROL SYSTEM



### NOTE

Only applies to power connection 3x400 V.



### NOTE

Mark the relevant electrical cabinet with a warning about external voltage, in those cases where a component in the cabinet has a separate supply.

If you wish to connect external operating voltage for the control system to F470 on the immersion heater circuit board (AA1) the edge connector at AA1:X2 must be moved to AA1:X9 (as illustrated).

When connecting external operating voltage for the control system with separate earth-fault breaker, disconnect the blue cable from terminal block X7:24 on the immersion heater circuit board (AA1) and connect in the enclosed top clamp together with the incoming operating zero. Connect a blue cable (min 0.75 mm<sup>2</sup>) between the top clamp and X11:N on the immersion heater circuit board (as illustrated).

Operating voltage (230VAC) is connected to AA1:X11 (as illustrated).

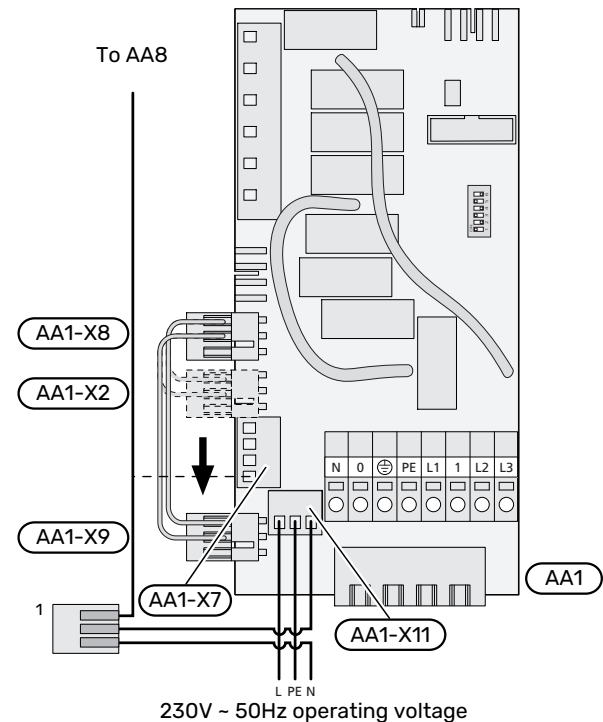

<sup>1</sup>Only with separate residual current device.

## SWITCHING FROM 3X400 V TO 1X230 V

F470 can be switched from 3x400 V to 1x230 V by connecting the supply to L1 and L3.

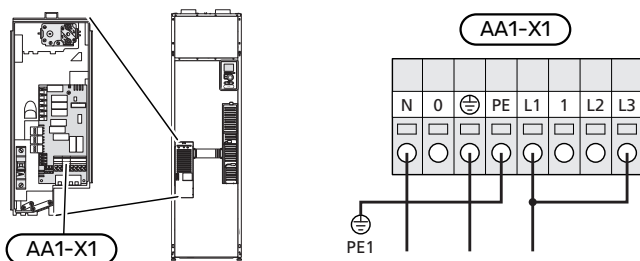

If the room sensor is used in a room with underfloor heating, it should only have an indicative function, not control of the room temperature.

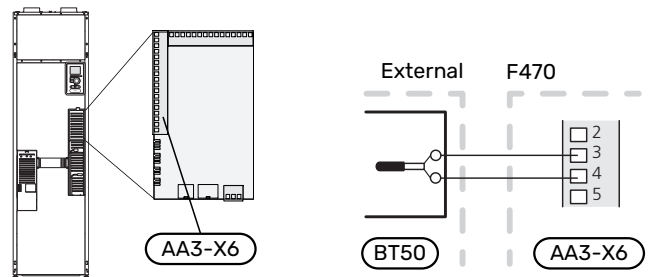

## OUTSIDE SENSOR

The outdoor temperature sensor (BT1) is placed in the shade on a wall facing north or north-west, so it is unaffected, for example, by the morning sun.

Connect the outdoor temperature sensor to terminal block X6:1 and X6:2 on the input board (AA3).

If a conduit is used it must be sealed to prevent condensation in the sensor capsule.

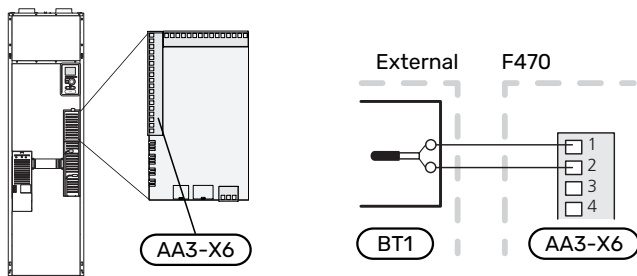

## Caution

Changes of temperature in accommodation take time. For example, short time periods in combination with underfloor heating will not give a noticeable difference in room temperature.

## ROOM SENSOR

F470 is supplied with an enclosed room sensor (BT50). The room sensor has a number of functions:

1. Shows current room temperature in the display on F470.
2. Option of changing the room temperature in °C.
3. Provides the option of fine-tuning the room temperature.

Install the sensor in a neutral position where the set temperature is wanted.

A suitable location is on a free inner wall in a hall approx. 1.5 m above the floor. It is important that the sensor is not prevented from measuring the correct room temperature, for example by being located in a recess, between shelves, behind a curtain, above or close to a heat source, in a draught from an external door or in direct sunlight. Closed radiator thermostats can also cause problems.

F470 operates without the room sensor, but if you want to read the home's indoor temperature from the display on F470, the sensor must be fitted. Connect the room sensor to X6:3 and X6:4 on the input board (AA3).

If the room temperature sensor will have a controlling function, it is activated in menu 1.9.4 - "room sensor settings".

## Settings

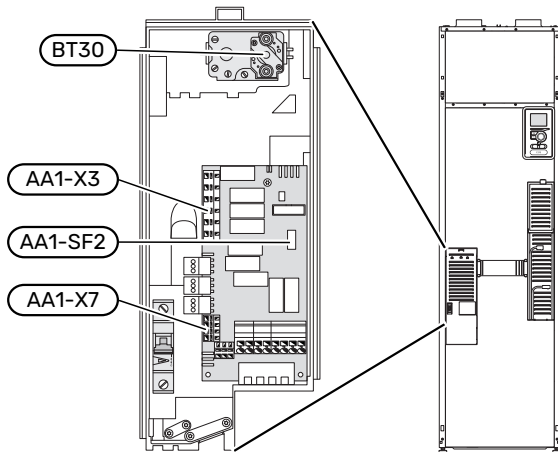

### ELECTRICAL ADDITION - MAXIMUM OUTPUT

The immersion heater output is divided into steps, according to the table.

Setting maximum output in the electric additional heat is done in menu 5.1.12.

When switching from 3x400 V to 1x230 V, the immersion heater must be limited to 2 kW. Min. fuse rating 16 A.

### Power steps of the immersion heater

Electrical addition (kW)	Max (A) L1	Max (A) L2	Max (A) L3
0.0	6.3	-	-
2.0	6.3	-	8.7
4.7	6.3	11.6	8.7
5.6 <sup>1</sup>	6.3	11.6	11.6
8.0	17.9	11.6	11.6
10.3	17.9	12.7	20.3

<sup>1</sup> Factory setting

The table displays the maximum phase current for the relevant power step for the heat pump.

If the current sensors are connected, the heat pump monitors the phase currents and allocates the electrical steps automatically to the least loaded phase.

### EMERGENCY MODE

When the heat pump is set to emergency mode (SF1 is set to  $\Delta$ ), only the most necessary functions are activated.

- The compressor and fans are off and heating is managed by the immersion heater.
- The load monitor is not connected.

### Power in emergency mode

The immersion heater's output in emergency mode is set with the dipswitch (S2) on the immersion heater circuit board (AA1) according to the table below.

kW	1	2	3	4	5	6
2.0	off	off	off	off	off	on
4.7	off	off	off	off	on	on
5.3	off	off	on	on	on	off
8.0 <sup>1</sup>	on	off	on	off	on	off
10.3	on	off	on	on	on	on

<sup>1</sup> Factory setting

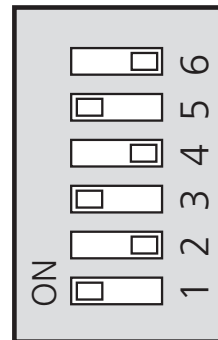

The image shows the dip-switch (AA1-S2) in the factory setting.

## Optional connections

### LOAD MONITOR

#### Integrated load monitor

F470 is equipped with a simple form of integrated load monitor, which limits the power steps for the electric additional heat by calculating whether future power steps can be connected to the relevant phase without exceeding the current for the specified main fuse.

If the current would exceed the specified main fuse, the power step is not permitted. The size of the property's main fuse is specified in menu 5.1.12 - "internal electrical addition".

#### Load monitor with current sensor

When many power-consuming products are connected in the property at the same time as the compressor and/or the electric additional heat is operating, there is a risk of the property's main fuses tripping.

F470 is equipped with a load monitor that, with the help of a current sensor, controls the power steps for the electric additional heat by redistributing the power between the different phases or, alternatively, disengages the electric additional heat step-by-step if there is an overload in a phase.

Reconnection occurs when the other current consumption is reduced.

## Connection and activation of current sensors

1. Install a current sensor on each incoming phase conduct- or into the electrical distribution unit. This is best done in the electrical distribution unit.
2. Connect the current sensors to a multi-core cable in an enclosure directly adjacent to the electrical distribution unit. The multi-core cable between the enclosure and F470 must have a cable area of at least 0.5 mm<sup>2</sup>.

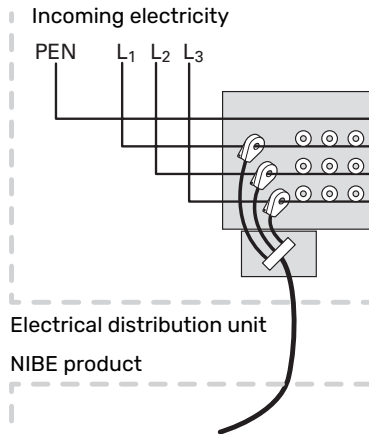

3. Connect the cable to the input board (AA3) on terminal block X4:1-4 where X4:1 is the common terminal block for the three current sensors.

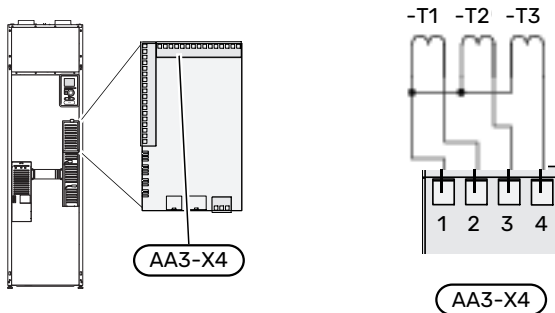

4. Specify the size of the property's main fuse in menu 5.1.12 - "internal electrical addition".
5. Activate phase detection in menu 5.1.12 - "internal electrical addition". Read more about phase detection in section "Menu 5.1.12 - internal electrical addition".

## CONNECTING EXTERNAL ENERGY METER



### CAUTION!

Connection of external energy meter requires version 35 or later on the input board (AA3) as well as "display version" 8816 or later.

One or two energy meters (BE6, BE7) are connected to terminal block X22 and/or X23 on input board (AA3).

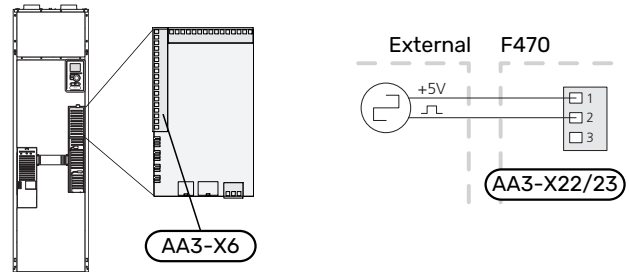

Activate the energy meter(s) in menu 5.2.4 and then set the desired value (energy per pulse) in menu 5.3.21.

## MYUPLINK

Connect the network connected cable (straight, Cat.5e UTP) with RJ45-contact (male) to RJ45 contact (female) on the rear of the heat pump.

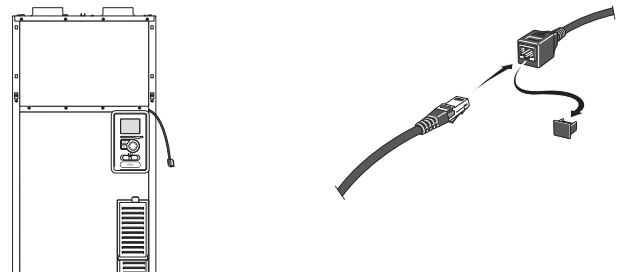

## EXTERNAL CONNECTION OPTIONS

F470 has software-controlled AUX inputs and outputs for connecting the external switch function (contact has to be potential-free) or sensor.

In menu 5.4 - "soft in/outputs", you select the AUX connection to which each function has been connected.

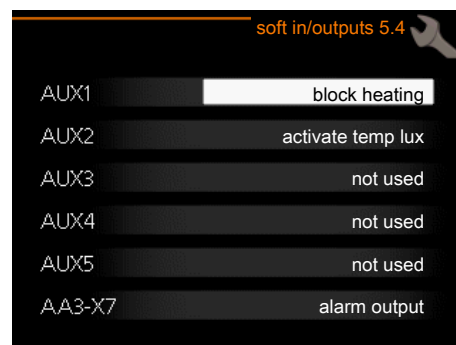

For certain functions, accessories may be required.



### TIP

Some of the following functions can also be activated and scheduled via menu settings.

## Selectable inputs

Selectable inputs on the input board (AA3) for these functions are:

AUX1	AA3-X6:9-10
AUX2	AA3-X6:11-12
AUX3	AA3-X6:13-14
AUX4	AA3-X6:15-16
AUX5	AA3-X6:17-18

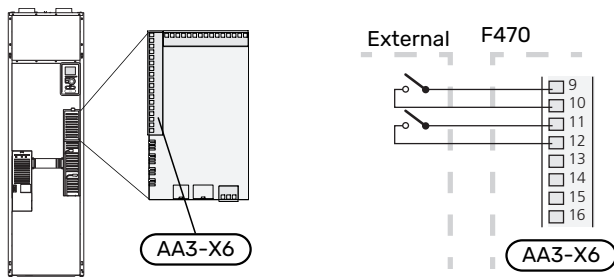

The example above uses the inputs AUX1 (X6:9-10) and AUX2 (X6:11-12) on the input board (AA3).

## Selectable outputs

A selectable output is AA3-X7.

The output is a potential-free switching relay.

When switch (SF1) is in the "U" or "Δ" position, the relay is in the alarm position.

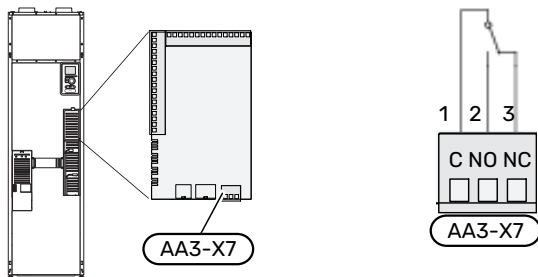

### Caution

The relay output may be subjected to a max load of 2 A at resistive load (230 V-).



### TIP

The AXC accessory is required if more than one function is to be connected to the AUX output.

## Possible selection for AUX inputs

### Monitor

Available options are:

- pressure switch for climate system (NC).
- alarm from external units.  
The alarm is connected to the control, which means that the malfunction is shown as an information message in the display. Potential free signal of type NO or NC.

### External activation of functions

An external switch function can be connected to F470 to activate various functions. The function is activated during the time the switch is closed.

Possible functions that can be activated:

- hot water comfort mode "temporary lux"
- hot water comfort mode "economy"
- "external adjustment"

When the switch is closed, the temperature changes in °C (if the room sensor is connected and activated). If a room sensor is not connected or not activated, the desired change of "temperature" (heating curve offset) is set with the number of steps selected. The value is adjustable between -10 and +10. External adjustment of climate systems 2 to 8 requires accessories.

- climate system 1 to 8

Setting the value for the change is performed in menu 1.9.2 - "external adjustment".

- activation of one of four fan speeds.

The following options are available:

- "activate fan speed 1 (NO)" - "activate fan speed 4 (NO)"
- "activate fan speed 1 (NC)"

The fan speed is activated during the time the switch is closed. Normal speed is resumed when the switch is opened again.

- SG ready



### Caution

This function can only be used in mains networks that support the "SG Ready" standard.

"SG Ready" requires two AUX inputs.

"SG Ready" is a smart form of tariff control where your electricity supplier can affect the indoor and hot water temperatures or simply block the additional heat and/or the compressor in the heat pump at certain times of the day (can be selected in menu 4.1.5 after the function is activated). Activate the function by connecting potential-free switch functions to two inputs selected in menu 5.4 (SG Ready A and SG Ready B).

Closed or open switch means one of the following:

- Blocking (A: Closed, B: Open)

"SG Ready" is active. The compressor in the heat pump and additional heat is blocked.

- Normal mode (A: Open, B: Open)

"SG Ready" is not active. No effect on the system.

- Low price mode (A: Open, B: Closed)

"SG Ready" is active. The system focuses on costs savings and can for example exploit a low tariff from the electricity supplier or over-capacity from any own power source (effect on the system can be adjusted in the menu 4.1.5).

- Overcapacity mode (A: Closed, B: Closed)

"SG Ready" is active. The system is permitted to run at full capacity at over capacity (very low price) with the electricity supplier (effect on the system is settable in menu 4.1.5).

(A = SG Ready A and B = SG Ready B)

- +Adjust

Using +Adjust, the installation communicates with the underfloor heating's control centre\* and adjusts the heating curve and calculated supply temperature according to the underfloor heating system's reconnection.

Activate the climate system you want +Adjust to affect by highlighting the function and pressing the OK button.

\*Support for +Adjust required



### Caution

This accessory may require a software update in your F470. The version can be checked in the "Service info" menu 3.1. Visit [nibeuplink.com](http://nibeuplink.com) and click on the "Software" tab to download the latest software to your installation.



### Caution

In systems with both underfloor heating and radiators, NIBE ECS 40/41 should be used for optimum operation.

## External blocking of functions

An external switch function can be connected to F470 for blocking various functions. The switch must be potential-free and a closed switch results in blocking.



### NOTE

Blocking entails a risk of freezing.

Functions that can be blocked:

- hot water (hot water production). Any hot water circulation (HWC) remains in operation.
- heating (blocking of heating demand)

- internally controlled additional heat
- compressor
- tariff blocking (additional heat, compressor, heating and hot water are disconnected)

## Possible selections for AUX output

### Indication

- alarm
- holiday
- away mode for "smart home" (complement to the functions in menu 4.1.7 - "smart home")

### Control

- circulation pump for hot water circulation
- external heating medium pump
- external frost protection damper (QN42)

### Blocking

- supply air heating (accessory BSA 10 is required)



### NOTE

The relevant distribution box must be marked with a warning about external voltage.

An external circulation pump is connected to the AUX output, as illustrated below.

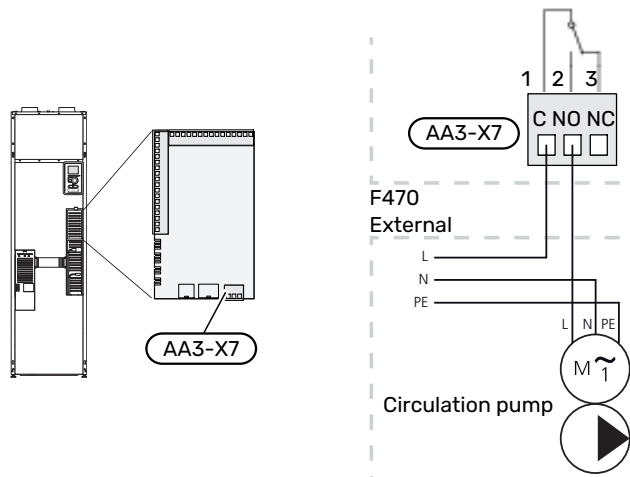

## Connecting accessories

Instructions for connecting accessories are provided in the manual accompanying the accessory. See page 56 for the list of the accessories that can be used with F470.

# Commissioning and adjusting

## Preparations

1. Check that the switch (SF1) is in position "⏻".
2. Check that the filling valves (QM10) and (QM11) are fully closed.



### Caution

Check the miniature circuit-breaker (FC1). It could have tripped during transport.



### NOTE

Do not start F470 if there is a risk that the water in the system has frozen.

3. Vent the supply air coil via its vent valve (QM21).
4. Keep topping up and venting until all air has been removed and the pressure is correct.



### NOTE

The vent pipe from the container must be drained of water before air can be released. This means that the system is not necessarily bled despite the flow of water when the bleed valve (QM20) is opened.

## Filling and venting

### FILLING THE HOT WATER HEATER

1. Open a hot water tap in the house.
2. Open the filling valve (QM10). Afterwards, this valve must be fully open during operation.
3. When the water that comes out of the hot water tap is no longer mixed with air, the water heater is full and the tap can be closed.

### FILLING THE CLIMATE SYSTEM

1. Check that the shut-off valves for the heating system (QM31) and (QM32) are open.
2. Open the vent valves (QM20) and (QM21).
3. Open the filling valves (QM11), (QM13). The heating unit and the rest of the climate system fill with water.
4. When the water exiting the vent valves (QM20) and (QM21) is no longer mixed with air, close the valves.
5. After a while, the pressure begins to rise on the pressure gauge (BP5). When the pressure reaches 2.5 bar (0.25 MPa), the safety valve (FL2) starts to release water. Now, close one filling valve (QM11).
6. Reduce the boiler pressure to the normal working range (approx. 1 bar) by opening the vent valves (QM20) and (QM21) or the safety valve (FL2).
7. Check that there is water in the overflow cup (WM1).

If the overflow cup requires topping up:

1. Carefully turn the safety valve for hot water (FL1) anti-clockwise.

### VENTING THE CLIMATE SYSTEM

1. Turn the power switch (SF1) to ⏻.
2. Vent the heat pump via the vent valve (QM20) and the rest of the climate system via its respective vent valves.

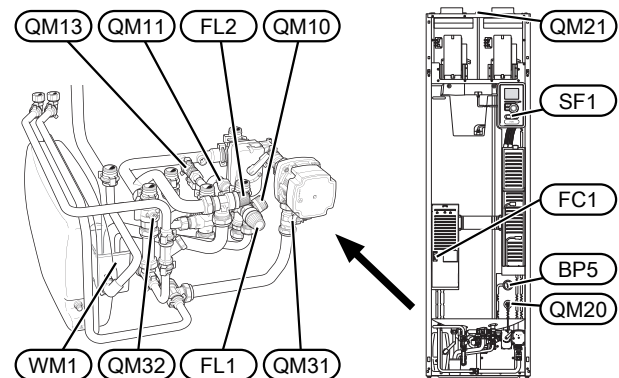

# Start-up and inspection

## START GUIDE



### NOTE

There must be water in the climate system before the switch is set to "I".

1. Set switch (SF1) on F470 to position "I".
2. Follow the instructions in the display's start guide. If the start guide does not start when you start the F470, you can start it manually in menu 5.7.



### TIP

See page 40 for a more in-depth introduction to the heat pump's control system (operation, menus etc.).

## Commissioning

The first time the installation is started a start guide is started. The start guide instructions state what needs to be carried out at the first start together with a run through of the installation's basic settings.

The start guide ensures that the start-up is carried out correctly and, for this reason, cannot be skipped.



### Caution

As long as the start guide is active, no function in the installation will start automatically.

The start guide will appear at each restart of the installation, until it is deselected on the last page.

## Operation in the start guide

A. Page

B. Name and menu number

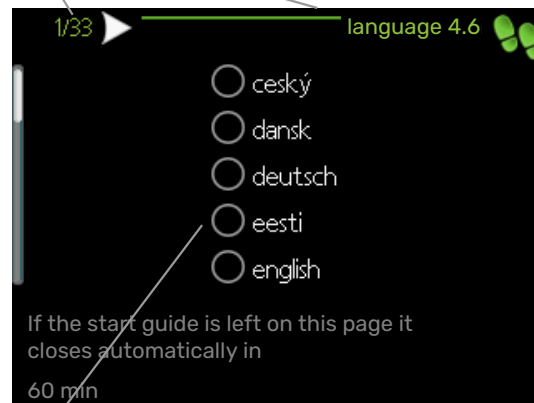

C. Option / setting

### A. Page

Here you can see how far you have come in the start guide.

Scroll between the pages of the start guide as follows:

1. Turn the control knob until one of the arrows in the top left corner (at the page number) has been marked.
2. Press the OK button to skip between the pages in the start guide.

### B. Name and menu number

Here, you can see which menu in the control system this page of the start guide is based on. The digits in brackets refer to the menu number in the control system.

If you want to read more about affected menus either consult the help menu or read the user manual.

### C. Option / setting

Make settings for the system here.



## SETTING THE VENTILATION

The ventilation must be set according to applicable standards. The supply air flow is adjusted so that it is 80% of the exhaust air flow. The settings are made in menus 5.1.5 - "fan speed" and 5.1.6 - "fan sp. supply air".

Even if ventilation is roughly set at installation it is important that a ventilation adjustment is ordered and permitted.



### NOTE

Order a ventilation adjustment to complete the setting.

### Ventilation capacity, supply air

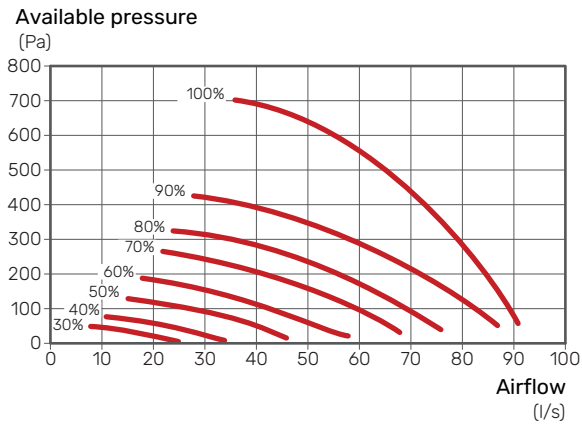

### Fan output, supply air

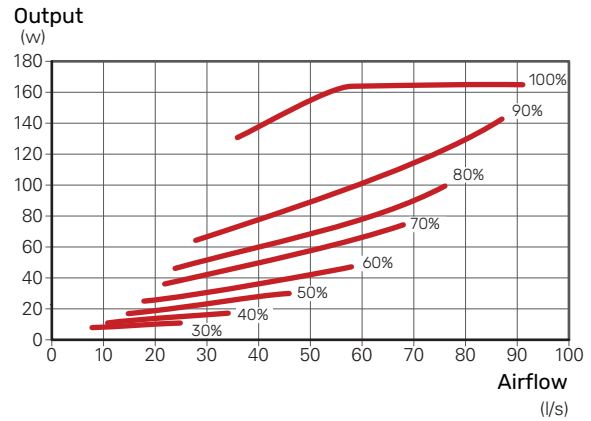

### Ventilation capacity, exhaust air

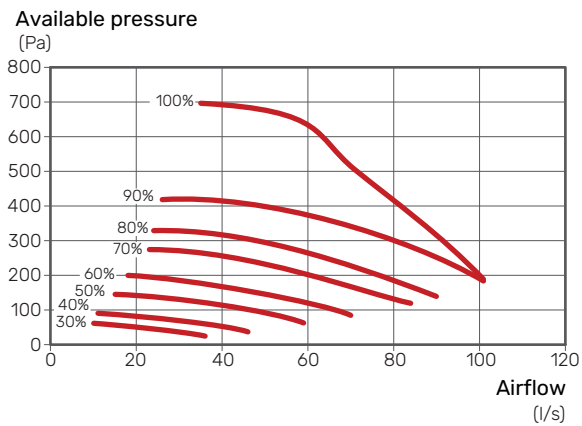

### Fan output, exhaust air

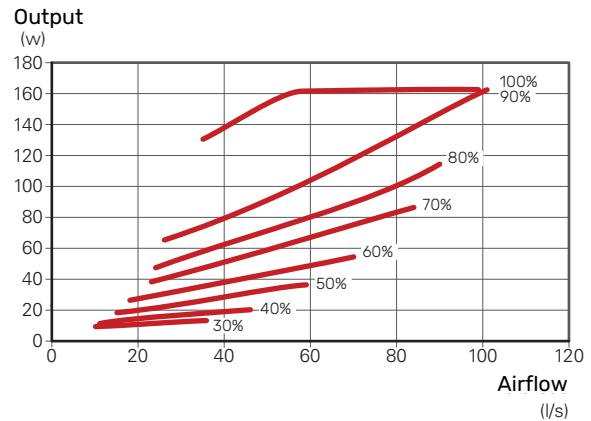

### Specific fan power

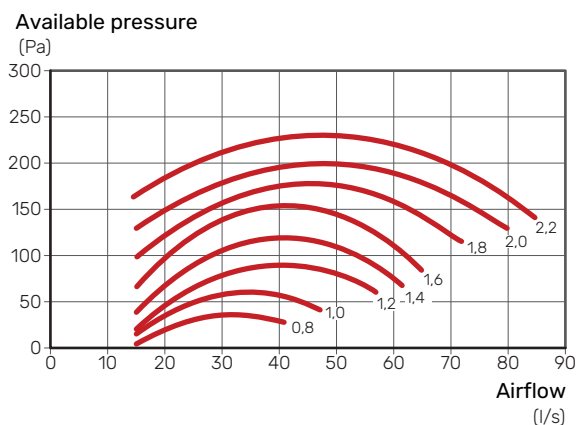

The diagram shows the SFP rating with both the fans' power consumption ( $W/(l/s)$ ).

## SUPPLY AIR BATTERY

### Water flow through the supply air coil

The water flow through the supply air coil is set by means of a trim valve (RN1). This valve must be adjusted to prevent unnecessary energy consumption in the accommodation. The additional output is determined according to the diagram

below. The supply air temperature must be approximately the same as the indoor temperature, preferably a few degrees lower.



#### TIP

Post-adjust the trim valve on a cold day.

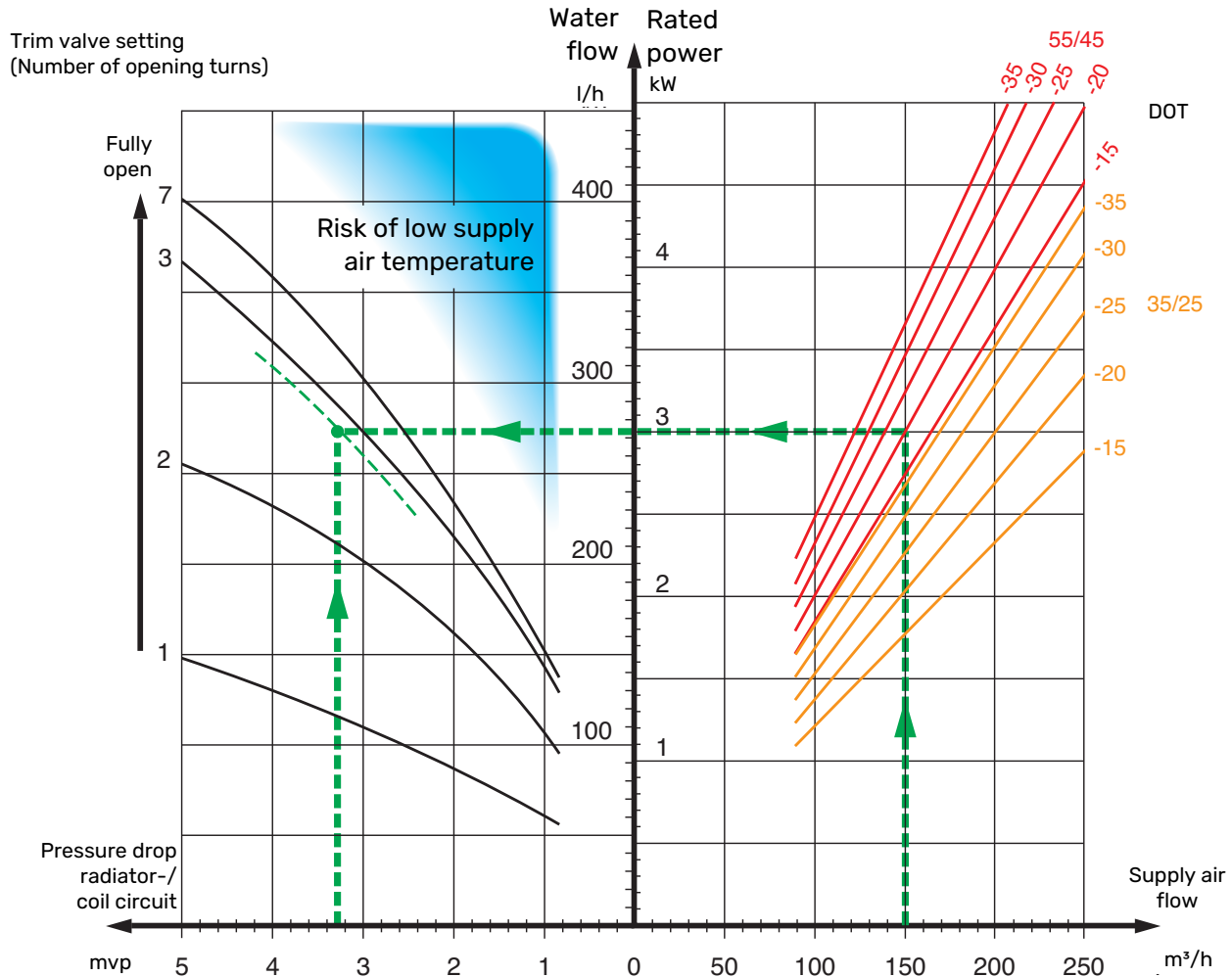

The delivered output in the diagram is calculated when dimensioning the heating system 55/45°C respective 35/25°C (underfloor heating).

Example: If the supply flow is regulated to 150 m³/h and DOT is -20 °C at a pump pressure (= pressure drop coil circuit) of 3.3 mvp (33 kPa), gives the setting 2.8 on the trim valve.

This means the trim valve must be opened 2.8 turns from the closed position. At the same time it can be read that the coil is supplying the supply air with approximately 3 kW of additional output at -20°C.



#### NOTE

Vent the coil using the venting screw (QM21) repeatedly in order to ensure the circulation through the coil.

### COMMISSIONING WITHOUT FANS

The heat pump can be run without recovery, as only an electric boiler, to produce heat and hot water, for example before the ventilation installation is complete.

1. Enter menu 4.2 - "op. mode" and select "add. heat only"
2. Enter menu 5.1.5 - "fan sp. exhaust air" and reduce the fan speed to 0%.
3. In addition, go to menu 5.1.6 - "fan sp. supply air" and reduce the fan speed on the supply air fan to 0%.



#### NOTE

Select operating mode "auto" or "manual" when the heat pump is to run on recovery again.

## SETTING CIRCULATION PUMP

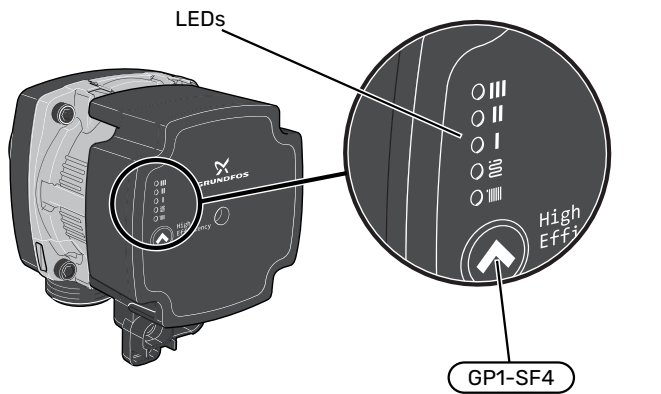

The circulation pump (GP1) is equipped with five LEDs. In normal mode, the LEDs show the pump's setting by lighting up in green and/or yellow. The LEDs can also indicate an alarm, in which case they light up in red and yellow.



The circulation pump's (GP1) various settings are selected by pressing the switch (GP1-SF4).

Choose between 5 different settings on the circulation pump.

- proportional pressure auto adapt (PPAA)
- constant pressure auto adapt (CPAA)
- proportional pressure (PP)
- constant pressure (CP)
- constant curve (CC).

The circulation pump's factory setting is CP, speed 3.

## Proportional pressure auto adapt (PPAA)

The circulation pump continually regulates the flow through the system with a great deal of freedom, to ensure minimum pump power consumption.

The setting is intended for radiator systems. Due to optimisation to low pumping capacity, the flow may be insufficient in certain systems.

## Capacity, circulation pump (PPAA)

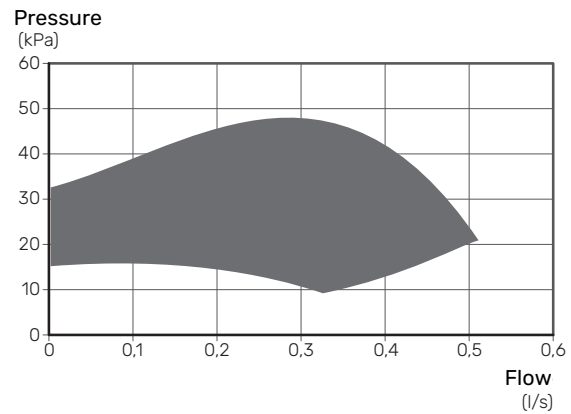

## Power, circulation pump (PPAA)

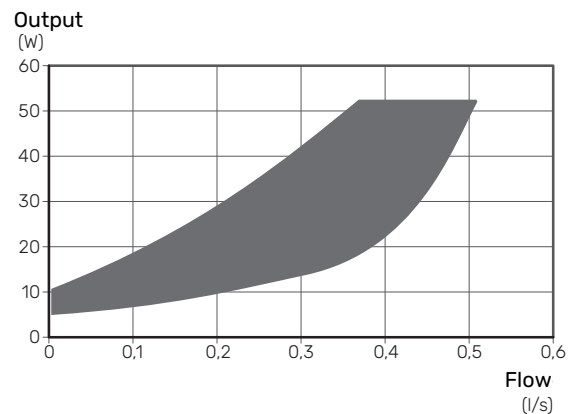

Setting PPAA	
LED indication	

### Constant pressure auto adapt (CPAA)

The circulation pump continually regulates the flow through the system with a great deal of freedom, to ensure minimum pump power consumption.

The setting is intended for underfloor heating systems. Due to optimisation to low pumping capacity, the flow may be insufficient in certain systems.

### Capacity, circulation pump (CPAA)

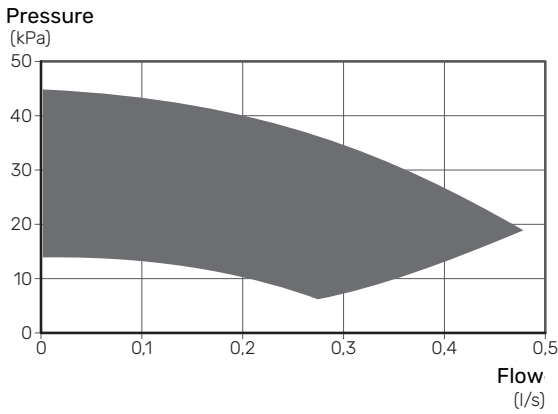

### Power, circulation pump (CPAA)

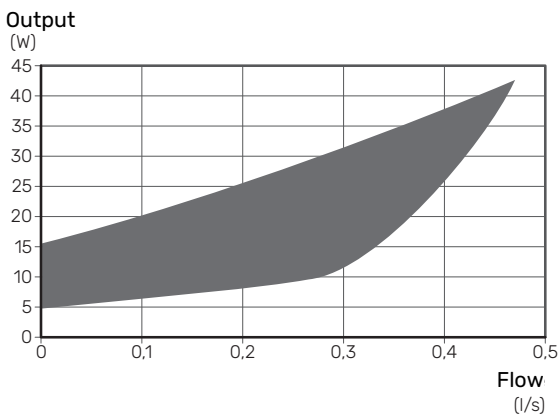

Setting CPAA	
LED indication	

### Proportional pressure (PP)

Within a limited range, the circulation pump is permitted to regulate its speed to an optimum system pressure. Speed 1, 2 or 3 is selected based on maximum flow requirement.

The setting is intended for radiator systems.

### Capacity, circulation pump (PP)

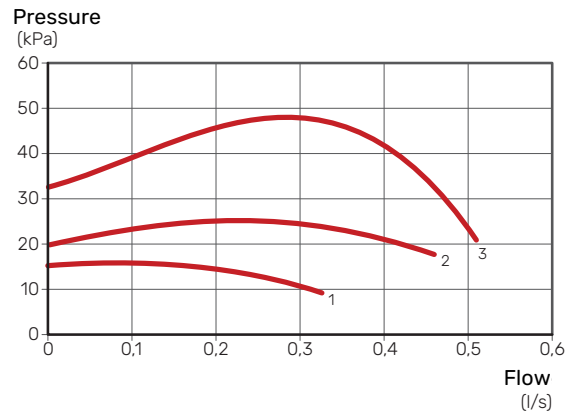

### Output, circulation pump (PP)

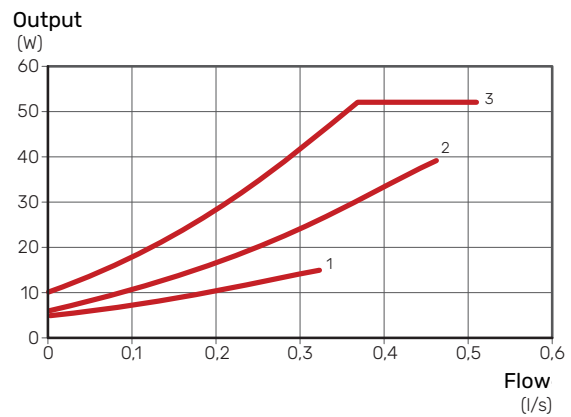

Pump speed PP	1	2	3
LED indication			

### Constant pressure (CP)

Within a limited range, the circulation pump is permitted to regulate its speed to a constant system pressure. Speed 1, 2 or 3 is selected based on maximum flow requirement.

The setting is intended for underfloor heating systems.

### Capacity, circulation pump (CP)

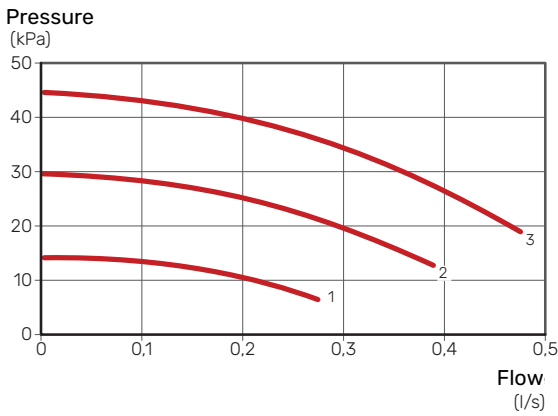

### Constant curve (CC)

The circulation pump's speed is fixed and no regulation takes place. Speed is selected based on maximum flow requirement.

The setting can be used when very high flows are required.

### Capacity, circulation pump (CC)

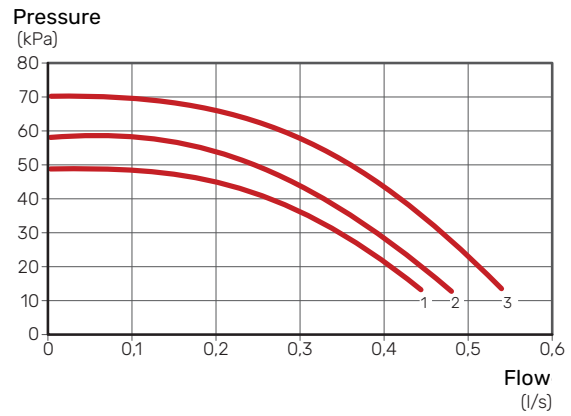

### Output, circulation pump (CP)

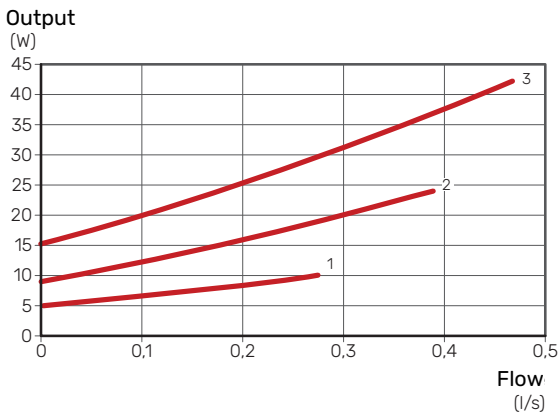

### Output, circulation pump (CC)

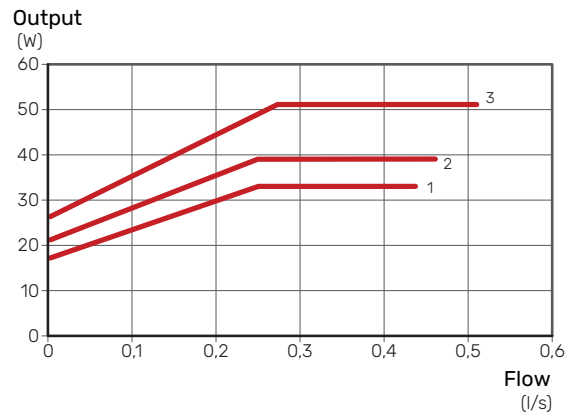

Pump speed CP	1	2	3 1
LED indication			



Pump speed CC	1	2	3
LED indication			

1 The circulation pump's factory setting

## Alarm

If an alarm occurs, LED  shines red.

When one or more alarms are active, this is indicated according to the following table. If more than one alarm is active, the one with the highest priority is displayed.

Cause / Action	
The rotor is blocked. Wait or release the rotor shaft.	
Supply voltage too low. Check the supply voltage.	
Electrical fault. Check the supply voltage or replace the circulation pump.	

## Setting the heating curve

In the menu "heating curve", you can see the heating curve for your house. The task of the curve is to provide an uniform indoor temperature, regardless of the outdoor temperature, and thereby energy-efficient operation. Based on this curve, the F470 determines the temperature of the water to the climate system (the supply temperature) and thus the indoor temperature.

### CURVE COEFFICIENT

The slope of the heating curve indicates how many degrees the supply temperature is to be increased/reduced when the outdoor temperature drops/increases. A steeper slope means a higher supply temperature at a certain outdoor temperature.

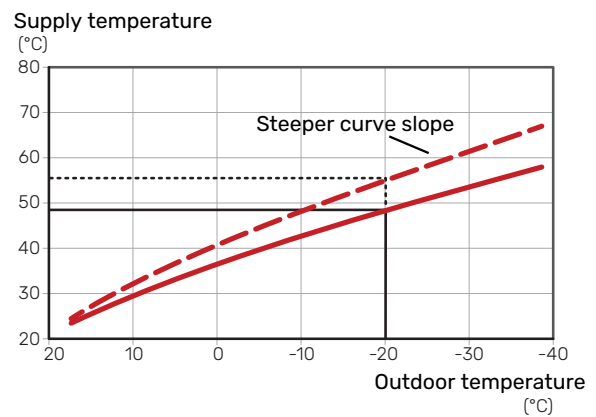

The optimum curve slope depends on the climate conditions in your location, whether the house has radiators, fan coils or underfloor heating and how well insulated the house is.

The heating curve is set when the heating installation is installed, but may need adjusting later. Normally, the curve will not need further adjustment.

### CURVE OFFSET

An offset of the heating curve means that the supply temperature changes by the same amount for all outdoor temperatures, e.g. a curve offset of +2 steps increases the supply temperature by 5 °C at all outdoor temperatures.

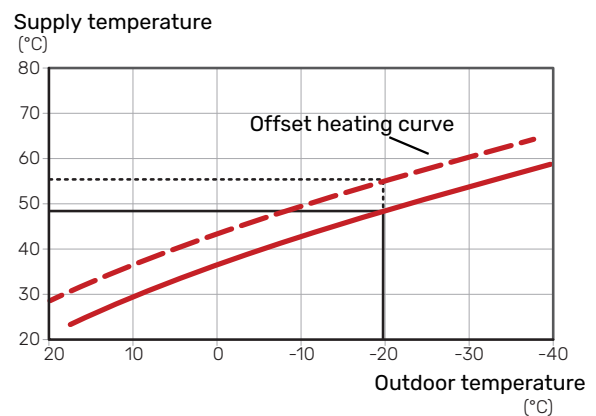

## SUPPLY TEMPERATURE – MAXIMUM AND MINIMUM VALUES

Because the flow line temperature cannot be calculated higher than the set maximum value or lower than the set minimum value the heating curve flattens out at these temperatures.

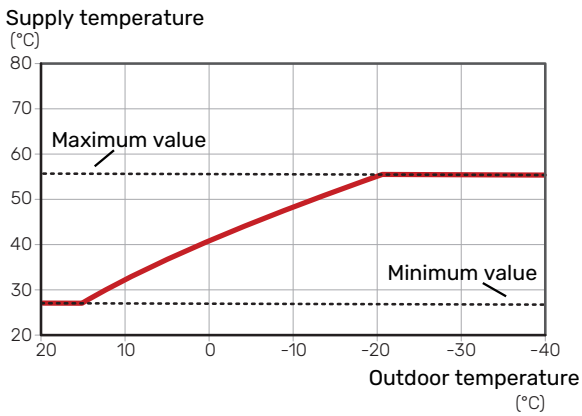

### Caution

With underfloor heating systems, the maximum supply temperature is normally set between 35 and 45 °C.

## ADJUSTMENT OF CURVE

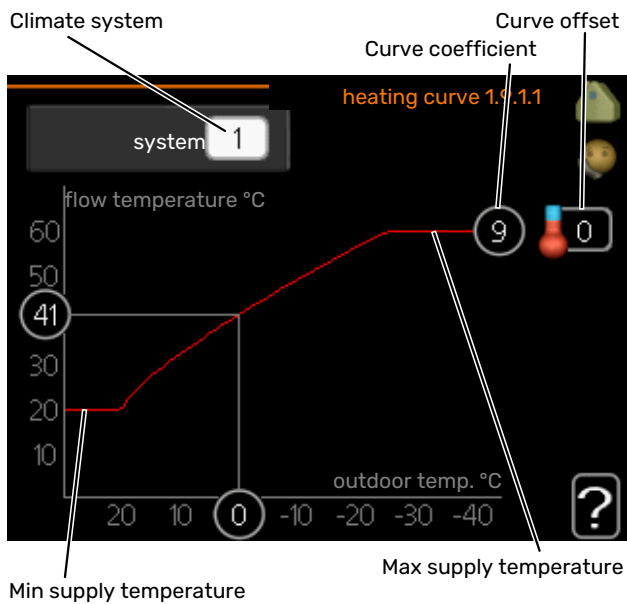

1. Select the climate system (if more than one) for which the curve is to be changed.
2. Select curve slope and curve offset.

### Caution

If you need to adjust "min. flow line temp." and/or "max flow line temperature", you do this in other menus.

Settings for "min. flow line temp." in menu 1.9.3.

Settings for "max flow line temperature" in menu 5.1.2.

### Caution

Curve 0 means that "own curve" is used.

Settings for "own curve" are made in menu 1.9.7.

## TO READ OFF A HEATING CURVE

1. Turn the control knob so that the ring on the shaft with the outdoor temperature is marked.
2. Press the OK button.
3. Follow the grey line up to the curve and out to the left to read off the value for the supply temperature at the selected outdoor temperature.
4. You can now select to take read outs for different outdoor temperatures by turning the control knob to the right or left and read off the corresponding flow temperature.
5. Press the OK or Back button to exit read off mode.

# Control - Introduction

## Display unit

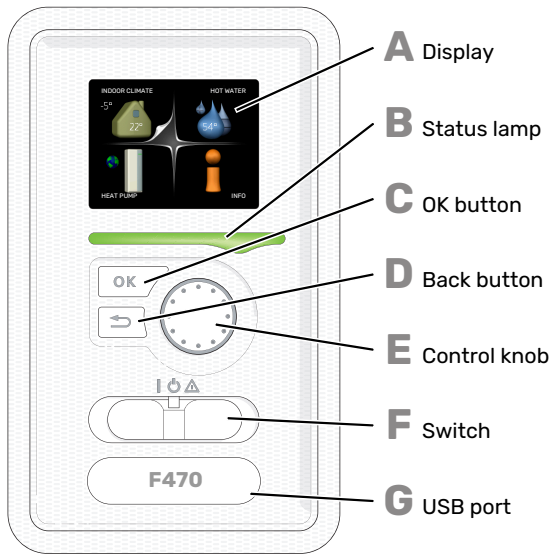

- A DISPLAY**  
Instructions, settings and operational information are shown on the display. You can easily navigate between the different menus and options to set the comfort or obtain the information you require.
- B STATUS LAMP**  
The status lamp indicates the status of the heat pump. It:
- lights green during normal operation.
  - lights yellow in emergency mode.
  - lights red in the event of a deployed alarm.
- C OK BUTTON**  
The OK button is used to:
- confirm selections of sub menus/options/set values/page in the start guide.
- D BACK BUTTON**  
The back button is used to:
- go back to the previous menu.
  - change a setting that has not been confirmed.
- E CONTROL KNOB**  
The control knob can be turned to the right or left. You can:
- scroll in menus and between options.
  - increase and decrease the values.
  - change page in multiple page instructions (for example help text and service info).
- F SWITCH (SF1)**  
The switch assumes three positions:
- On (I)
  - Standby (U)
  - Emergency mode (Δ) (see page 50)
- Emergency mode must only be used in the event of a fault on the heat pump. In this mode, the compressor and fans switch off and the immersion heater engages. The heat pump display is not illuminated and the status lamp illuminates yellow.
- G USB PORT**  
The USB port is hidden beneath the plastic badge with the product name on it.  
The USB port is used to update the software.  
Visit [nibeuplink.com](http://nibeuplink.com) and click the "Software" tab to download the latest software for your installation.

## Menu system

When the door to the heat pump is opened, the menu system's four main menus are shown in the display as well as certain basic information.

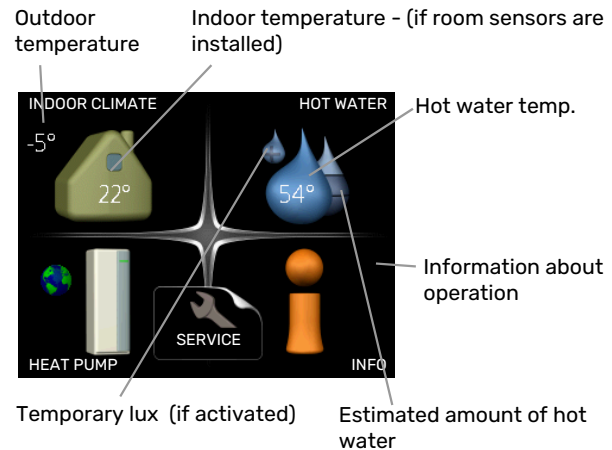









- MENU 1 - INDOOR CLIMATE**  
Setting and scheduling the indoor climate. See information in the help menu or user manual.
- MENU 2 - HOT WATER**  
Setting and scheduling hot water production. See information in the help menu or user manual.
- MENU 3 - INFO**  
Display of temperature and other operating information and access to the alarm log. See information in the help menu or user manual.
- MENU 4 - HEAT PUMP**  
Setting time, date, language, display, operating mode etc. See information in the help menu or user manual.
- MENU 5 - SERVICE**  
Advanced settings. These settings are not available to the end user. The menu is visible when the Back button is pressed for 7 seconds when you are in the start menu. See page 46.



## SYMBOLS IN THE DISPLAY

The following symbols may appear on the display during operation.

Symbol	Description
	This symbol appears by the information sign if there is information in menu 3.1 that you should note.
	<p>These two symbols indicate whether the compressor or addition is blocked in F470.</p> <p>These can, for example, be blocked depending on which operating mode is selected in menu 4.2, if blocking is scheduled in menu 4.9.5 or if an alarm has occurred that blocks one of them.</p> <p> Blocking the compressor.</p> <p> Blocking additional heat.</p>
	This symbol appears if periodic increase or lux mode for the hot water is activated.
	This symbol indicates whether "holiday setting" is active in 4.7.
	This symbol indicates whether F470 has contact with NIBE Uplink.
	This symbol indicates the actual speed of the fan if the speed has changed from the normal setting.
	This symbol is visible in installations with active solar accessories.

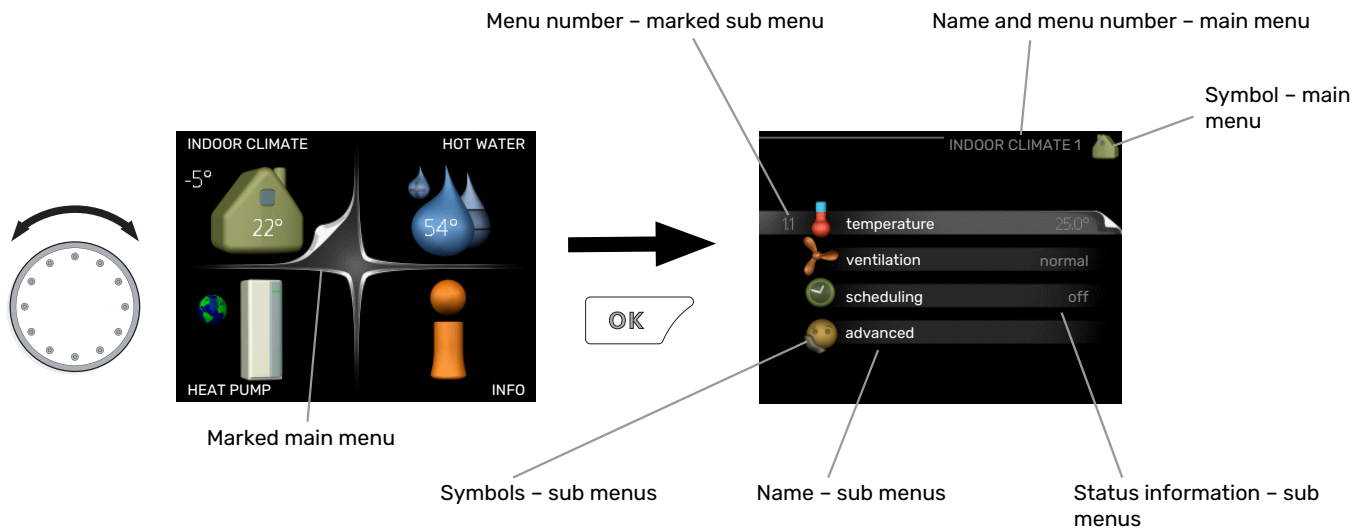

## OPERATION

To move the cursor, turn the control knob to the left or the right. The marked position is white and/or has a turned up tab.



## SELECTING MENU

To advance in the menu system select a main menu by marking it and then pressing the OK button. A new window then opens with sub menus.

Select one of the sub menus by marking it and then pressing the OK button.

## SETTING A VALUE



Values to be changed

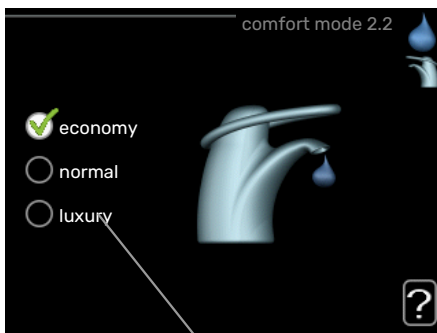

## SELECTING OPTIONS



Alternative

In an options menu the current selected option is indicated by a green tick. 

To select another option:

1. Mark the applicable option. One of the options is pre-selected (white). 
2. Press the OK button to confirm the selected option. The selected option has a green tick. 

To set a value:

1. Mark the value you want to set using the control knob. 01
2. Press the OK button. The background of the value becomes green, which means that you have accessed the setting mode. 01
3. Turn the control knob to the right to increase the value and to the left to reduce the value. 04
4. Press the OK button to confirm the value you have set. To change and return to the original value, press the Back button. 04

## USE THE VIRTUAL KEYBOARD

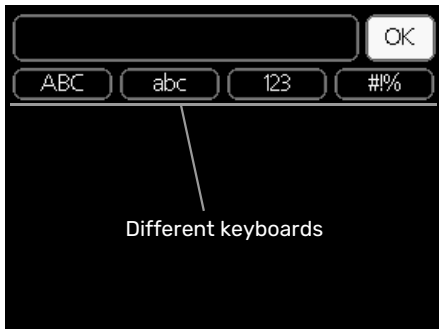

In some menus where text may require entering, a virtual keyboard is available.

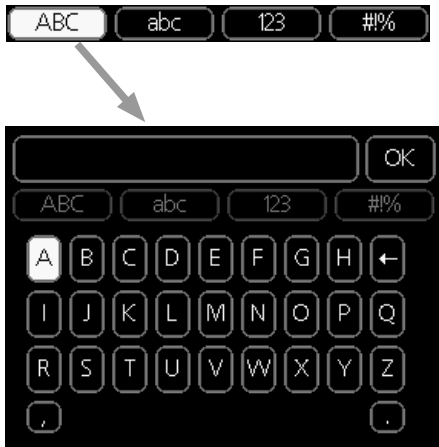

Depending on the menu, you can gain access to different character sets which you can select using the control knob. To change character table, press the Back button. If a menu only has one character set the keyboard is displayed directly. When you have finished writing, mark "OK" and press the OK button.

## SCROLL THROUGH THE WINDOWS

A menu can consist of several windows. Turn the control knob to scroll between the windows.

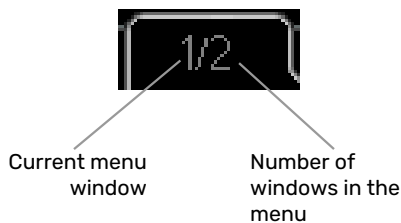

## Scroll through the windows in the start guide



Arrows to scroll through window in start guide

1. Turn the control knob until one of the arrows in the top left corner (at the page number) has been marked.
2. Press the OK button to skip between the steps in the start guide.

## HELP MENU

 In many menus there is a symbol that indicates that extra help is available.

To access the help text:

1. Use the control knob to select the help symbol.
2. Press the OK button.

The help text often consists of several windows that you can scroll between using the control knob.

# Control - Menus

## Menu 1 - INDOOR CLIMATE

### OVERVIEW

1 - INDOOR CLIMATE	1.1 - temperature	
	1.2 - ventilation	
	1.3 - scheduling	1.3.1 - heating
		1.3.3 - ventilation
	1.9 - advanced	1.9.1.1 - heating curve
		1.9.2 - external adjustment
		1.9.3 - min. flow line temp.
		1.9.4 - room sensor settings
		1.9.6 - fan return time
		1.9.7 - own curve
	1.9.8 - point offset	
	1.9.9 - night cooling	

## Menu 2 - HOT WATER

### OVERVIEW

2 - HOT WATER	2.1 - temporary lux	
	2.2 - comfort mode	
	2.3 - scheduling	
	2.9 - advanced	2.9.1 - periodic increase
		2.9.2 - hot water recirc. *

\* Accessory needed.

## Menu 3 - INFO

### OVERVIEW

3 - INFO	3.1 - service info
	3.2 - compressor info
	3.3 - add. heat info
	3.4 - alarm log
	3.5 - indoor temp. log

## Menu 4 - HEAT PUMP

### OVERVIEW

4 - HEAT PUMP	4.1 - plus functions *	4.1.3 - internet	4.1.3.1 - NIBE Uplink
			4.1.3.8 - tcp/ip settings
			4.1.3.9 - proxy settings
			4.1.5 - SG Ready
			4.1.6 - smart price adaption™
	4.1.7 - smart home		
	Menu 4.1.10 - solar electricity *		
	4.2 - op. mode		
	4.3 - my icons		
	4.4 - time & date		
	4.6 - language		
	4.7 - holiday setting		
	4.9 - advanced	4.9.2 - auto mode setting	
		4.9.4 - factory setting user	
		4.9.5 - schedule blocking	

\* Accessory needed.

# Menu 5 - SERVICE

## OVERVIEW

5 - SERVICE	5.1 - operating settings	5.1.1 - hot water settings
		5.1.2 - max flow line temperature
		5.1.4 - alarm actions
		5.1.5 - fan sp. exhaust air
		5.1.6 - fan sp. supply air
		5.1.12 - internal electrical addition
		5.1.99 - other settings
	5.2 - system settings	5.2.4 - accessories
	5.3 - accessory settings	5.3.3 - extra climate system *
		5.3.21 - flow sensor / energy meter*
	5.4 - soft in/outputs	
	5.5 - factory setting service	
	5.6 - forced control	
	5.7 - start guide	
	5.8 - quick start	
	5.9 - floor drying function	
	5.10 - change log	
	5.12 - country	

\* Accessory needed.

Go to the main menu and hold the Back button in for 7 seconds to access the Service menu.

### Sub-menus

Menu **SERVICE** has orange text and is intended for the advanced user. This menu has several sub-menus. Status information for the relevant menu can be found on the display to the right of the menus.

**operating settings** Operating settings for the heat pump.

**system settings** System settings for the heat pump, activating accessories etc.

**accessory settings** Operational settings for different accessories.

**soft in/outputs** Setting software-controlled inputs and outputs on input board (AA3).

**factory setting service** Total reset of all settings (including settings available to the user ) to default values.

**forced control** Forced control of the different components in the heat pump.

**start guide** Manual start of the start guide which is run the first time the heat pump is started.

**quick start** Quick starting the compressor.



**NOTE**  
Incorrect settings in the service menus can damage the heat pump.

### MENU 5.1 - OPERATING SETTINGS

Operating settings can be made for the heat pump in the sub menus.

### MENU 5.1.1 - HOT WATER SETTINGS



#### NOTE

The factory set tap water temperatures specified in the manual can vary due to the directives in force in different countries. From this menu, you can check the relevant settings for the system.

#### economy

Setting range start temp. economy: 15 - 52 °C

Factory setting start temp. economy: 45 °C

Setting range stop temp. economy: 15 - 55 °C

Factory setting stop temp. economy: 51 °C

#### normal

Setting range start temp. normal: 15 - 52 °C

Factory setting start temp. normal: 49 °C

Setting range stop temp. normal: 15 - 55 °C

Factory setting stop temp. normal: 55 °C

#### luxury

Setting range start temp. lux: 15 - 62 °C

Factory setting start temp. lux: 52 °C

Setting range stop temp. lux: 15 - 65 °C

Factory setting stop temp. lux: 58 °C

#### stop temp. per. increase

Setting range: 55 - 70 °C

Factory setting: 60 °C

Here you set the start and stop temperature of the hot water for the different comfort options in menu 2.2 as well as the stop temperature for periodic increase in menu 2.9.1.

### MENU 5.1.2 - MAX FLOW LINE TEMPERATURE

#### climate system

Setting range: 20-70 °C

Default value: 60 °C

Here, you set the maximum supply temperature for the climate system. If the installation has more than one climate system, individual maximum supply temperatures can be set for each system. Climate system 2 - 8 cannot be set to a higher max supply temperature than climate system 1.



#### Caution

For underfloor heating systems, max flow line temperature should normally be set to between 35 and 45°C.

Check the max floor temperature with your floor supplier.

### MENU 5.1.4 - ALARM ACTIONS

Select if you want the heat pump to alert you that there is an alarm in the display here.



#### Caution

If no alarm action is selected, it can result in higher energy consumption in the event of an alarm.

### MENU 5.1.5 - FAN SP. EXHAUST AIR

#### normal and speed 1-4

Setting range: 0 - 100 %

Set the speed for the five different selectable speeds for the fan here.



#### Caution

An incorrectly set ventilation flow can damage the house and may also increase energy consumption.

### MENU 5.1.6 - FAN SP. SUPPLY AIR

#### normal and speed 1-4

Setting range: 0 - 100 %

Set the speed for the five different selectable speeds for the fan here.



#### Caution

An incorrectly set value may damage the house in the long term and possibly increase energy consumption.

### MENU 5.1.12 - INTERNAL ELECTRICAL ADDITION

#### set max electrical add.

Setting range 0 - 10.25 kW

Factory setting 5.6 kW

#### fuse size

Setting range: 1 - 200 A

Factory setting: 16 A

#### transformation ratio

Setting range: 300 - 3000

Factory setting: 300

Here you set the max. electrical output of the internal electrical addition in F470 and the fuse size for the installation.

"*detect phase order*": Here, you also check which current sensor is installed on which incoming phase to the property (this only applies if you have current sensors installed, see page 27). Check by selecting "detect phase order" and pressing the OK button.

The results of these checks appear just below the menu selection "detect phase order".



#### TIP

Search again if the phase detection fails. The detection process is very sensitive and is easily affected by other appliances in the accommodation.

*transformation ratio*: The transformer ratio can be changed to match different types of current sensor. The factory setting is adjusted according to the enclosed current sensors.

### MENU 5.1.99 - OTHER SETTINGS

#### trend calculation limit

Setting range: 0 - 20 °C

Default value: 7 °C

#### transfer time

Setting range: 1 - 60 min

Factory setting: 45 min

#### months btwn filter alarms

Setting range: 1 - 12

Default value: 3

Here you can set trend calculation limit, transfer time, months btwn filter alarms and fan synch. operation .

### trend calculation limit

Here you set at what outdoor temperature the trend calculation is to be active. Above this limit, connection of the immersion heater is delayed and the immersion heater is not connected if the compressor is able to increase the temperature in the vessel.

### transfer time

Here you can set transfer time between heating and hot water production in F470. During the transfer time the compressor maintains the stop temperature that applied during hot water production.

### months btwn filter alarms

Here you set the number of months between alarms for a reminder to clean the filters in F470.

### fan synch. operation

Select whether the fan is to maintain the same speed, regardless of whether the compressor is operating or not, or alternatively run at different speeds. If the function is activated, fan speed 2 applies when the compressor is not in operation, and normal fan speed applies when the compressor is in operation.

## MENU 5.2 - SYSTEM SETTINGS

Make different system settings for the heat pump here, e.g. which accessories are installed.

### MENU 5.2.4 - ACCESSORIES

Inform the heat pump which accessories are installed here.

There are two ways of activating connected accessories. You can either mark the alternative in the list or use the automatic function "search installed acc."

### search installed acc.

Mark "search installed acc." and press the OK button to automatically find connected accessories for F470.

## MENU 5.3 - ACCESSORY SETTINGS

The operating settings for accessories that are installed and activated are made in the sub-menus for this.

### MENU 5.3.3 - EXTRA CLIMATE SYSTEM

#### mixing valve amplifier

Setting range: 0.1 – 10.0

Default value: 1.0

#### mixing valve step delay

Setting range: 10 – 300 s

Default values: 30 s

#### Contr. pump GP10

Setting range: on/off

Factory setting: off

Here, you select which climate system (2 - 8) you wish to set.

*mixing valve amplifier, mixing valve step delay:* Here, you set the shunt amplification and shunt waiting time for the various extra climate systems that are installed.

*Contr. pump GP10:* Here, you can set the speed of the circulation pump manually.

See the accessory installation instructions for function description.

## MENU 5.3.21 - FLOW SENSOR / ENERGY METER

### Energy meter

#### set mode

Setting range: energy per pulse / pulses per kWh

Default value: energy per pulse

#### energy per pulse

Setting range: 0 – 10000 Wh

Factory setting: 1000 Wh

#### pulses per kWh

Setting range: 1 – 10000

Factory setting: 500

### Energy meter (Electricity meter)

The energy meter(s) is used to send pulse signals every time a certain amount of energy has been consumed.

*energy per pulse:* Here you set the amount of energy to which each pulse will correspond.

*pulses per kWh:* Here you set the number of pulses per kWh that are sent to F470.

## MENU 5.4 - SOFT IN/OUTPUTS

Here, you can select which input/output on the input board (AA3) the external switch function (page 28) will be connected to.

Selectable inputs on terminal block AUX 1-5 (AA3-X6:9-18) and output AA3-X7 on the input board.

## MENU 5.5 - FACTORY SETTING SERVICE

All settings can be reset (including settings available to the user) to default values here.



### Caution

When resetting, the start guide is displayed the next time the heat pump is restarted.

## MENU 5.6 - FORCED CONTROL

You can force control the different components in the heat pump and any connected accessories here.

## MENU 5.7 - START GUIDE

When the heat pump is started for the first time the start guide starts automatically. Start it manually here.

See page 32 for more information about the start guide.



## MENU 5.8 - QUICK START

It is possible to start the compressor from here.



### Caution

There must be a heating or hot water demand to start the compressor.



### NOTE

Do not quick start the compressor too many times over a short period of time, as this could damage the compressor and its surrounding equipment.

## MENU 5.9 - FLOOR DRYING FUNCTION

### length of period 1 - 7

Setting range: 0 - 30 days

Factory setting, period 1 - 3, 5 - 7: 2 days

Factory setting, period 4: 3 days

### temp. period 1 - 7

Setting range: 15 - 70 °C

Default value:

temp. period 1	20 °C
temp. period 2	30 °C
temp. period 3	40 °C
temp. period 4	45 °C
temp. period 5	40 °C
temp. period 6	30 °C
temp. period 7	20 °C

Set the function for under floor drying here.

You can set up to seven time periods with different calculated supply temperatures. If fewer than seven periods are to be used, set the remaining periods to 0 days.

Mark the active window to activate the underfloor drying function. A counter at the bottom shows the number of days the function has been active.



### TIP

If operating mode "add. heat only" is to be used, select it in menu 4.2.



### TIP

It is possible to save a floor drying log that shows when the concrete slab has reached the correct temperature. See section "Logging floor drying" on page 53.

## MENU 5.10 - CHANGE LOG

Read off any previous changes to the control system here.

The date, time, ID no. (unique to particular setting) and the new set value are shown for every change.



### Caution

The change log is saved at restart and remains unchanged after factory setting.

## 5.12 - COUNTRY

Select here the country in which the product was installed. This allows access to country-specific settings in your product.

Language settings can be made regardless of this selection.



### Caution

This option locks after 24 hours, after restarting the display and during program updating.

# Service



## NOTE

Servicing and maintenance should only be carried out by persons with the necessary expertise.

When replacing components on F470 only replacement parts from NIBE may be used.

## Maintenance

Inform the user of necessary maintenance action.

### CLEANING THE OVERFLOW CUP/FLOOR DRAIN

Condensation forms when the heat pump is working. This condensation is routed via an overflow cup (WM1) to a drain, e.g. a floor drain.

The condensation water contains a certain amount of dust and particles.

Regularly check that the overflow cup (WM1) and any floor drain are not blocked; water must be able to run through freely. Clean, if necessary.



## NOTE

If the overflow cup or floor drain is blocked, water can flow over onto the floor in the installation area. To prevent damage to the building, a waterproof floor or floor membrane is recommended.

## Service actions

### EMERGENCY MODE

Emergency mode is used in event of operational interference and in conjunction with service.

Emergency mode is activated by setting switch (SF1) to "⚠". This means that:

- The status lamp illuminates yellow.
- The display is not lit and the control computer is not connected.
- The temperature in the heating section is controlled by a fixed thermostat (BT30) at 63 °C.
- The compressor and the fans are off and only the heating medium pump and the electric additional heat are active. The electric additional heat power in emergency mode is set on the electric addition PCB (AA1). See page 27 for instructions.
- The automatic heating control system is not operational, so manual mixing is required. This is done by turning the adjustment screw on the shunt motor (MA1) to "manual mode" and then turning the shunt knob to the desired position.

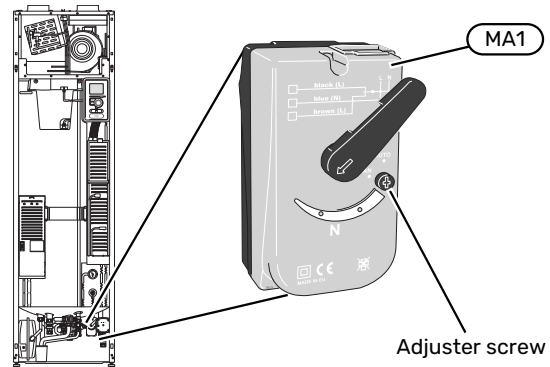

### DRAINING THE HOT WATER HEATER

The water heater can be drained through the safety valve (FL1) or via the overflow cup (WM1).



## NOTE

There may be some hot water, risk of scalding.

1. Disconnect the overflow pipe from the safety valve (FL1) and connect a hose to a draining pump instead. If a draining pump is not available, the water can be released directly into the overflow cup instead (WM1).
2. Open the safety valve (FL1).
3. Open a hot water tap to let air into the system. If this is not sufficient, detach the pipe connection (XL4) on the hot water side and ensure that air is entering.

### DRAINING THE CLIMATE SYSTEM

In order to carry out service on the climate system, it may be easier to drain the system first.



## NOTE

There may be some hot water, risk of scalding.

The hot water can be drained as follows:

- through the safety valve (FL2) via the overflow cup (WM1)
  - through a hose that is connected to the safety valve's (FL2) outlet
1. Open the safety valve.
  2. Set the vent valve for the climate system (QM20) in the open position for air supply.

### HELPING THE CIRCULATION PUMP TO START

The circulation pump in F470 has an automatic start help function. If necessary the pump can be started manually. In such cases, take the following action:

1. Turn off F470 by setting the switch (SF1) to "⏻".
2. Remove the front cover

3. Press in the screw for start help using a screwdriver as illustrated.
4. With the screw pressed in, turn the screwdriver in any direction.
5. Start F470 by setting the switch (SF1) to "I", and check that the circulation pump is working.

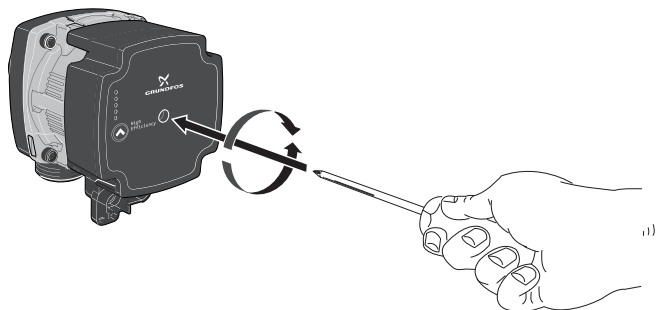

## TEMPERATURE SENSOR DATA

Temperature (°C)	Resistance (kOhm)	Voltage (VDC)
-10	56.20	3.047
0	33.02	2.889
10	20.02	2.673
20	12.51	2.399
30	8.045	2.083
40	5.306	1.752
50	3.583	1.426
60	2.467	1.136
70	1.739	0.891
80	1.246	0.691

## USB SERVICE OUTLET

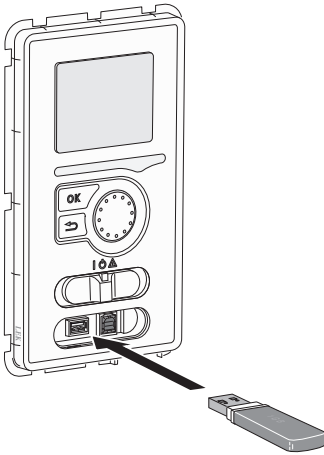

The display unit is equipped with a USB socket that can be used to update the software and save logged information in F470.

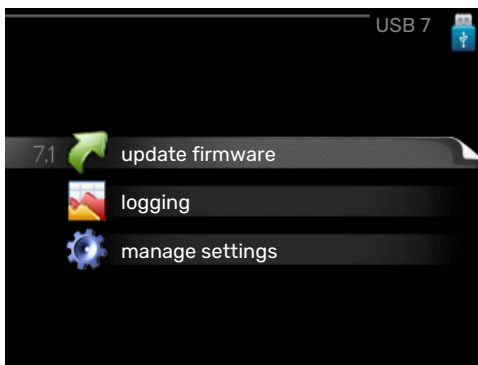
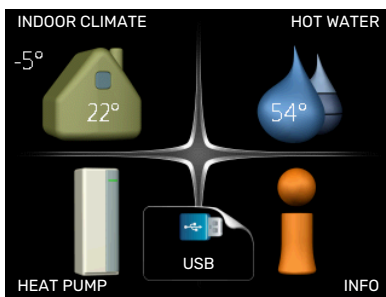

When a USB memory is connected, a new menu (menu 7) appears in the display.

### Menu 7.1 - "update firmware"

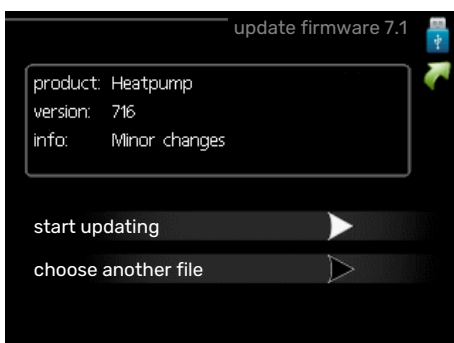

Here, you can update the software in F470.



### NOTE

For the following functions to work the USB memory must contain files with software for F470 from NIBE.

The fact box at the top of the display shows information (always in English) of the most probable update that the update software has selected from the USB memory.

This information states the product for which the software is intended, the software version and general information about it. If you want a file other than the one selected, the correct file can be selected through "choose another file".

### start updating

Select "start updating" if you want to start the update. You are asked whether you really want to update the software. Respond "yes" to continue or "no" to undo.

If you responded "yes" to the previous question the update starts and you can now follow the progress of the update on the display. When the update is complete F470 restarts.



### TIP

A software update does not reset the menu settings in F470.



### Caution

If the update is interrupted before it is complete (for example, by a power cut), the software can be reset to the previous version if the OK button is held in during start-up until the green lamp comes on (takes about 10 seconds).

### choose another file

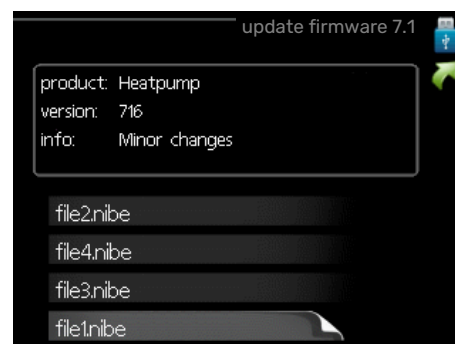

Select "choose another file" if you do not want to use the suggested software. When you scroll through the files, information about the marked software is shown in a fact box just as before. When you have selected a file with the OK button you will return to the previous page (menu 7.1) where you can choose to start the update.

## Menu 7.2 - logging

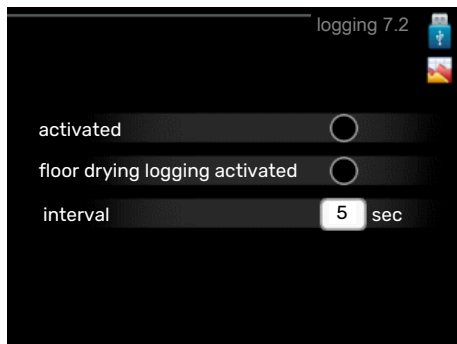

Setting range: 1 s – 60 min  
Factory setting range: 5 s

Here you can choose how current measurement values from F470 should be saved onto a log file on the USB memory.

1. Set the desired interval between loggings.
2. Tick "activated".
3. The present values from F470 are saved in a file in the USB memory at the set interval until "activated" is unticked.



### Caution

Untick "activated" before removing the USB memory.

## Logging floor drying

Here you can save a floor drying log on the USB memory and in this way see when the concrete slab reached the correct temperature.

- Make sure that "floor drying function" is activated in menu 5.9.
- Select "logging floor drying activated".
- A log file is now created, where the temperature and the immersion heater output can be read off. Logging continues until "logging floor drying activated" is deselected or until "floor drying function" is stopped.



### Caution

Deselect "logging floor drying activated" before you remove the USB memory.

## Menu 7.3 - manage settings

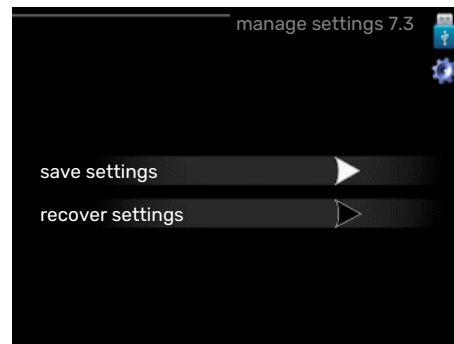

### save settings

Setting option: on/off

### recover settings

Setting option: on/off

In this menu, you save/upload menu settings to/from a USB memory stick.

*save settings:* Here, you save menu settings in order to restore them later or to copy the settings to another F470.



### Caution

When you save menu settings to the USB memory, you replace any previously saved settings on the USB memory.

*recover settings:* Here, you upload all menu settings from the USB memory stick.



### Caution

Resetting of menu settings from the USB memory cannot be undone.

# Disturbances in comfort

In most cases, F470 notes a malfunction (a malfunction can lead to disruption in comfort) and indicates this with alarms, and instructions for action, in the display.

## Info menu

All the heat pump measurement values are gathered under menu 3.1 in the heat pump menu system. Looking through the values in this menu can often simplify finding the source of the fault. See help menu or user manual for more information about menu 3.1.

## Manage alarm

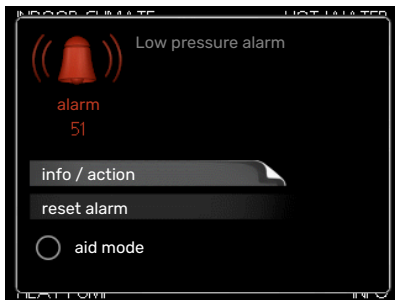

In the event of an alarm, some kind of malfunction has occurred, which is indicated by the status lamp changing from green continuously to red continuously. In addition, an alarm bell appears in the information window.

### ALARM

In the event of an alarm with a red status lamp, a malfunction has occurred that the heat pump cannot remedy itself. By turning the control knob and pressing the OK button, you can see in the display what type of alarm it is and reset it. You can also choose to set the heat pump to aid mode.

*info / action* Here you can read what the alarm means and receive tips on what you can do to correct the problem that caused the alarm.

*reset alarm* In many cases, it is sufficient to select "reset alarm" for the product to revert to normal operation. If a green light comes on after selecting "reset alarm", the alarm has been remedied. If the red light is still on, and a menu called "alarm" is visible in the display, the problem causing the alarm still remains.

*aid mode* "aid mode" is a type of emergency mode. This means that the heat pump produces heat and/or hot water even though there is some kind of problem. This could mean that the heat pump's compressor is not running. In this case, the immersion heater produces heat and/or hot water.



### Caution

To select aid mode an alarm action must be selected in the menu 5.1.4.



### Caution

Selecting "aid mode" is not the same as correcting the problem that caused the alarm. The status lamp will therefore continue to be red.

## Troubleshooting

If the operational interference is not shown in the display the following tips can be used:

### BASIC ACTIONS

Start by checking the following items:

- The switch's (SF1) position.
- Group and main fuses of the accommodation.
- The property's earth circuit breaker.
- The heat pump's RCD.
- Miniature circuit breaker for F470 (FC1).
- Temperature limiter for F470 (FQ10).
- Correctly set load monitor.

### LOW HOT WATER TEMPERATURE OR A LACK OF HOT WATER

- Closed or choked filling valve (QM10) for the hot water.
  - Open the valve.
- F470 in incorrect operating mode.
  - Enter menu 4.2. If mode "auto" is selected, select a higher value on "stop additional heat" in menu 4.9.2.
  - If mode "manual" is selected, select "addition".
- Large hot water consumption.
  - Wait until the hot water has heated up. Temporarily increased hot water capacity (temporary lux) can be activated in menu 2.1.
- Too low hot water setting.
  - Enter menu 2.2 and select a higher comfort mode.

### LOW ROOM TEMPERATURE

- Closed thermostats in several rooms.
    - Set the thermostats to max, in as many rooms as possible. Adjust the room temperature via menu 1.1, instead of choking the thermostats.
- See the "Saving tips" section in the User manual for more detailed information about how to best set the thermostats.
- F470 in incorrect operating mode.
    - Enter menu 4.2. If mode "auto" is selected, select a higher value on "stop heating" in menu 4.9.2.

- If mode "manual" is selected, select "heating". If this is not enough, select "addition".
- Too low set value on the automatic heating control.
  - Enter menu 1.1 "temperature" and adjust the offset heating curve up. If the room temperature is only low in cold weather the curve slope in menu 1.9.1 "heating curve" needs adjusting up.
- "Holiday mode" activated in menu 4.7.
  - Enter menu 4.7 and select "Off".
- External switch for changing room temperature activated.
  - Check any external switches.
- The heating medium pump (GP1) has stopped.
  - See section "Helping the circulation pump to start" on page 50.
- Air in the climate system.
  - Vent the climate system (see page 31).
- Closed valves (QM31), (QM32) to the climate system.
  - Open the valves.

### **HIGH ROOM TEMPERATURE**

- Too high set value on the automatic heating control.
  - Enter menu 1.1 (temperature) and reduce the offset heating curve. If the room temperature is only high in cold weather the curve slope in menu 1.9.1 "heating curve" needs adjusting down.
- External switch for changing room temperature activated.
  - Check any external switches.
- Trim valve to supply air coil (RN1) is not adjusted.
  - Adjust the valve (see diagram on page 34).

### **LOW SYSTEM PRESSURE**

- Not enough water in the climate system.
  - Top up the water in the climate system (see page 31).

### **LOW OR A LACK OF VENTILATION**

- The exhaust air filter (HQ10) and/or the supply air filter (HQ11) is clogged.
  - Clean or replace the filters.
- The ventilation is not adjusted.
  - Order/implement ventilation adjustment.
- Exhaust air device blocked or throttled down too much.
  - Check and clean the exhaust air devices.
- Fan speed in reduced mode.
  - Enter menu 1.2 and select "normal".
- External switch for changing the fan speed activated.
  - Check any external switches.

### **HIGH OR DISTRACTING VENTILATION**

- The exhaust air filter (HQ10) and/or the supply air filter (HQ11) is clogged.
  - Clean or replace the filters.
- The ventilation is not adjusted.
  - Order/implement ventilation adjustment.
- Fan speed in forced mode.
  - Enter menu 1.2 and select "normal".
- External switch for changing the fan speed activated.
  - Check any external switches.

### **LOW SUPPLY AIR TEMPERATURE**

- Air in the supply air battery
  - Bleed the supply air battery.
- Trim valve too restricted (RN1)
  - Adjust the trim valve (see diagram on page 34).

### **HIGH SUPPLY AIR TEMPERATURE**

- Trim valve (RN1) not sufficiently restricted.
  - Adjust the trim valve (see diagram on page 34).

### **THE COMPRESSOR DOES NOT START**

- There is no heating or hot water demand.
  - F470 does not call on heating or hot water.
- The heat pump defrosts.
  - The compressor starts, when defrosting is complete.
- Compressor blocked due to the temperature conditions.
  - Wait until the temperature is within the product's working range.
- Minimum time between compressor starts has not been reached.
  - Wait for at least 30 minutes and then check if the compressor has started.
- Alarm tripped.
  - Follow the display instructions.

# Accessories

Detailed information about the accessories and complete accessories list available at [nibe.eu](http://nibe.eu).

Not all accessories are available on all markets.

## BLOCKING OF SUPPLY AIR HEATING BSA 10

BSA 10 used to block supply air heating in F470 at the same time as some heat production is required in all or parts of the waterborne heating system.

Part no. 067 601

## DOCKING KIT DEH

There are separate docking kits available for connecting other heat sources to the heat pump.

### Docking kit wood/oil/pellets DEH 40

Part no. 066 101

### Docking kit gas DEH 41

Part no. 066 102

## EXTRA SHUNT GROUP ECS

This accessory is used when F470 is installed in houses with two or more different heating systems that require different supply temperatures.

### ECS 40 (Max 80 m<sup>2</sup>)

Part no 067 287

### ECS 41 (approx. 80-250 m<sup>2</sup>)

Part no 067 288

## ROOM UNIT RMU 40

The room unit is an accessory with a built-in room sensor, which allows the control and monitoring of F470 to be carried out in a different part of your home to where it is located.

Part no 067 064

## SOLAR PACKAGE NIBE PV

NIBE PV is a modular system comprising solar panels, assembly parts and inverters, which is used to produce your own electricity.

## ACCESSORY BOARD AXC 20

Accessory board for hot water circulation, BSA 10, damper for anti-freeze and/or external heating medium pump.

Part no. 067 609

## WATER HEATER

### Eminent

Water heater with immersion heater.

#### Eminent 35

Corrosion protection:

Copper Part no. 072 310

Enamel Part no. 072 300

Stainless Part no. 072 320

#### Eminent 55

Corrosion protection:

Copper Part no. 072 340

Enamel Part no. 072 330

Stainless Part no. 072 350

#### Eminent 100

Corrosion protection:

Copper Part no. 072 370

Enamel Part no. 072 360

Stainless Part no. 072 380

#### Eminent 120

Corrosion protection:

Stainless Part no. 072 384

### Compact

Water heater with immersion heater.

#### Compact 100

Corrosion protection:

Copper Part no. 084 010

#### Compact 200

Corrosion protection:

Copper Part no. 084 020

Enamel Part no. 084 070

Stainless Part no. 084 050

#### Compact 300

Corrosion protection:

Copper Part no. 084 030

Enamel Part no. 084 080

Stainless Part no. 084 060

## TOP CABINET TOC 30

Top cabinet, which conceals any pipes/ventilation ducts.

### Height 245 mm

Part no. 067 517

### Height 345 mm

Part no. 067 518

### Height 385-635 mm

Part no. 067 519



# Technical data

## Dimensions

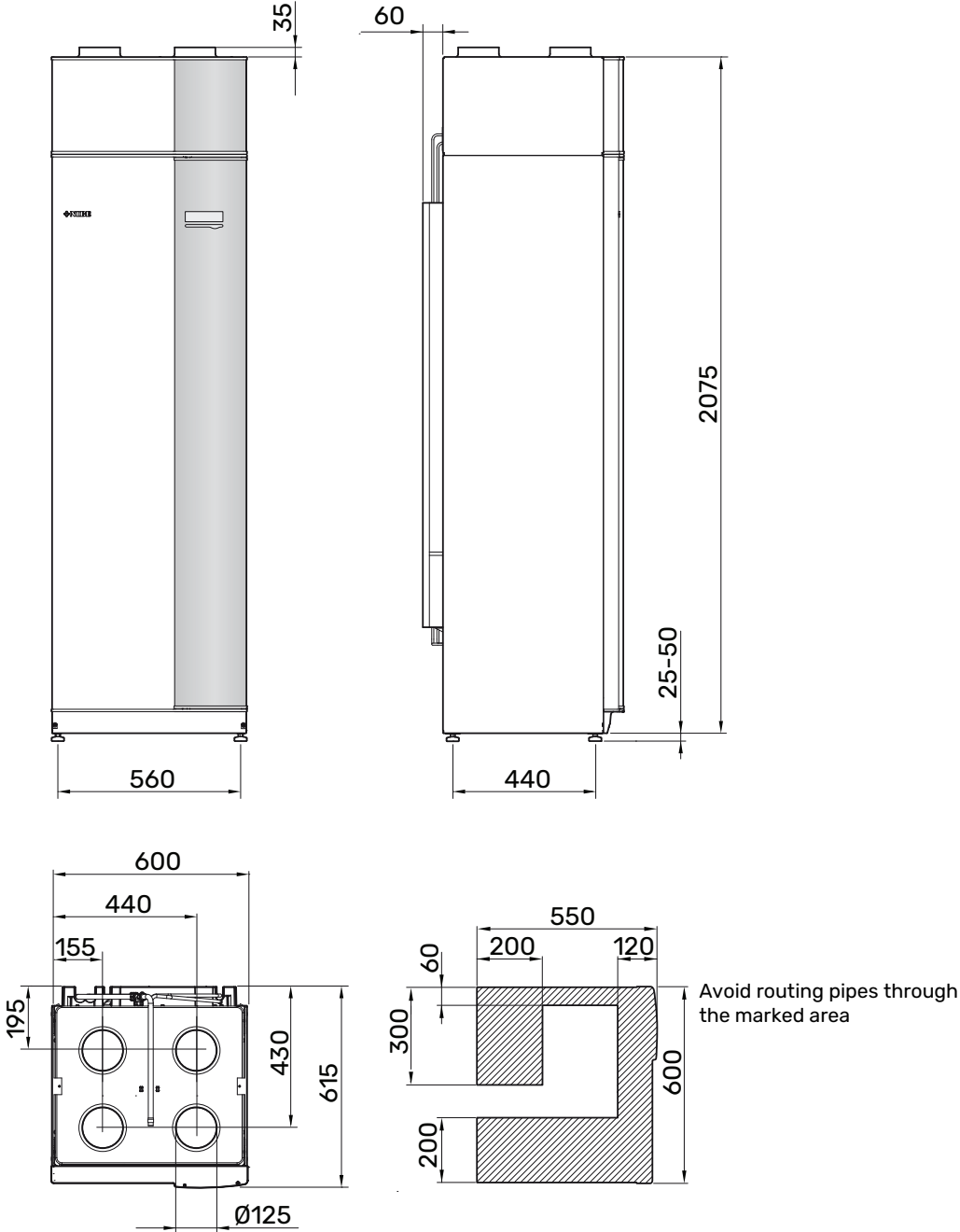

# Technical specifications

3x400 V		Stainless
<b>Output data according to EN 14 511</b>		
Heating capacity (P <sub>H</sub> )/COP <sup>1</sup>	kW/-	2.18 / 3.93
Heating capacity (P <sub>H</sub> )/COP <sup>2</sup>	kW/-	2.03 / 3.24
Heating capacity (P <sub>H</sub> )/COP <sup>3</sup>	kW/-	1.88 / 2.74
<b>Output data according to EN 14 825</b>		
Rated heating output (P <sub>designh</sub> )	kW	3
SCOP cold climate, 35°C / 55 °C		3.70 / 3.08
SCOP average climate, 35 °C / 55 °C		3.58 / 2.98
SCOP warm climate, 35°C / 55°C		3.58 / 2.98
<b>Additional power</b>		
Max power, immersion heater (factory setting)	kW	10.3 (5.6)
<b>Energy rating, average climate</b>		
The product's efficiency class room heating, average climate 35 / 55 °C <sup>4</sup>		A+ / A+
The system's efficiency class room heating, average climate 35 / 55 °C <sup>5</sup>		A+ / A+
Declared tap profile/efficiency class hot water heating <sup>6</sup>		L / A
<b>Electrical data</b>		
Rated voltage	V	400 V 3N - 50 Hz
Max operating current	A	20.3
Min. fuse rating	A	10
Drive output heating medium pump	W	4-34
Driving power exhaust air fan	W	10-165
Driving power supply air fan	W	10-165
Enclosure class		IP 21
Equipment Compliant with IEC 61000-3-12		
For Connection Design Purposes, Compliant with IEC 61000-3-3 technical requirements		
<b>Refrigerant circuit</b>		
Type of refrigerant		R290
Volume	kg	0.44
Cut-out value pressostat HP	MPa/bar	2.45 / 24.5
Cut-out value pressostat LP	MPa/bar	0.15 / 1.5
<b>Heating medium circuit</b>		
Opening pressure, safety valve	MPa/bar	0.25 / 2.5
Max temperature, supply line (factory setting)	°C	70 (60)
<b>Ventilation</b>		
Min. air flow at exhaust air temperature at least 20°C	l/s	28
Min. air flow at exhaust air temperature below 20°C	l/s	31
<b>Noise</b>		
Sound effect level according to EN 12 102 (L <sub>w(A)</sub> ) <sup>7</sup>	dB(A)	51.5-54.5
Sound pressure level in the installation room (L <sub>P(A)</sub> ) <sup>8</sup>	dB(A)	47.5-50.5
<b>Pipe connections</b>		
Heating medium ext Ø	mm	22
Hot water ext Ø	mm	22
Cold water ext Ø	mm	22
Docking ext Ø	mm	22
Ventilation Ø	mm	125

<sup>1</sup> A20(12)W35, exhaust air flow 56 l/s (200 m<sup>3</sup>/h)

<sup>2</sup> A20(12)W45, exhaust air flow 42 l/s (150 m<sup>3</sup>/h)

<sup>3</sup> A20(12)W55, exhaust air flow 31 l/s (110 m<sup>3</sup>/h)

<sup>4</sup> Scale for the product's efficiency class room heating: A+++ to D.

<sup>5</sup> Scale for the system's efficiency class room heating: A+++ to G. Reported efficiency for the system takes the product's temperature regulator into account.

<sup>6</sup> Scale for efficiency class hot water: A+ to F.

<sup>7</sup> The value varies with the selected fan curve. For more detailed sound data, including sound to channels, visit nibe.eu.

<sup>8</sup> The value can vary with the room's damping capacity. These values apply at a damping of 4 dB.

Other 3x400 V		Stainless
Water heater and heating section		
Volume heating section	litre	70
Volume, hot water heater	litre	170
Max pressure in hot water heater	MPa/bar	1.0 / 10.0
Capacity, hot water		
Tap volume 40°C according to EN 16 147( $V_{max.}$ ) <sup>1</sup>	litre	217
COP at Normal comfort ( $COP_p$ )		1.97
Idle loss at Normal comfort ( $P_{es}$ )	W	54
Dimensions and weight		
Width	mm	600
Depth	mm	616
Height incl. feet		2,100 - 2,125
Required ceiling height	mm	2,170
Weight	kg	204
Part No.		066 065

<sup>1</sup> A20(12) exhaust air flow 42 l/s (150 m<sup>3</sup>/h). Comfort mode, normal

# Energy labelling

## INFORMATION SHEET

Supplier		NIBE
Model		F470
Temperature application	°C	35 / 55
Declared load profile for water heating		L
Seasonal space heating energy efficiency class, average climate		A+ / A+
Water heating energy efficiency class, average climate		A
Rated heat output ( $P_{designh}$ ), average climate	kW	3 / 3
Annual energy consumption space heating, average climate	kWh	1505 / 1806
Annual energy consumption water heating, average climate	kWh	1299
Seasonal space heating energy efficiency, average climate	%	140 / 116
Water heating energy efficiency, average climate	%	79
Sound power level $L_{WA}$ indoors	dB	52
Rated heat output ( $P_{designh}$ ), cold climate	kW	3 / 3
Rated heat output ( $P_{designh}$ ), warm climate	kW	3 / 3
Annual energy consumption space heating, cold climate	kWh	1737 / 2091
Annual energy consumption water heating, cold climate	kWh	1299
Annual energy consumption space heating, warm climate	kWh	973 / 1168
Annual energy consumption water heating, warm climate	kWh	1299
Seasonal space heating energy efficiency, cold climate	%	145 / 120
Water heating energy efficiency, cold climate	%	79
Seasonal space heating energy efficiency, warm climate	%	140 / 116
Water heating energy efficiency, warm climate	%	79
Sound power level $L_{WA}$ outdoors	dB	-

Compressor motor is exempted from EU 2019/1781 due to that motors completely integrated into compressor and energy performance cannot be tested independently from the product.

## DATA FOR ENERGY EFFICIENCY OF THE PACKAGE

Model		F470
Temperature application	°C	35 / 55
Controller, class		VII
Controller, contribution to efficiency	%	3.5
Seasonal space heating energy efficiency of the package, average climate	%	143 / 119
Seasonal space heating energy efficiency class of the package, average climate		<b>A+ / A+</b>
Seasonal space heating energy efficiency of the package, cold climate	%	148 / 123
Seasonal space heating energy efficiency of the package, warm climate	%	143 / 119

Reported efficiency for the system also takes the temperature regulator into account. If the system is supplemented with external additional heat or solar heating, the total efficiency of the system must be recalculated.

## TECHNICAL DOCUMENTATION

Model				F470			
Type of heat pump	<input type="checkbox"/> Air-water <input checked="" type="checkbox"/> Exhaust-water <input type="checkbox"/> Brine-water <input type="checkbox"/> Water-water						
Low-temperature heat pump	<input type="checkbox"/> Yes <input checked="" type="checkbox"/> No						
Integrated immersion heater for additional heat	<input checked="" type="checkbox"/> Yes <input type="checkbox"/> No						
Heat pump combination heater	<input checked="" type="checkbox"/> Yes <input type="checkbox"/> No						
Climate	<input checked="" type="checkbox"/> Average <input type="checkbox"/> Cold <input type="checkbox"/> Warm						
Temperature application	<input checked="" type="checkbox"/> Medium (55°C) <input type="checkbox"/> Low (35°C)						
Applied standards	EN14825, EN16147						
Rated heat output	Prated	2,6	kW	Seasonal space heating energy efficiency	$\eta_s$	116	%
Declared capacity for space heating at part load and at outdoor temperature $T_j$				Declared coefficient of performance for space heating at part load and at outdoor temperature $T_j$			
$T_j = -7\text{ °C}$	Pdh	1.7	kW	$T_j = -7\text{ °C}$	COPd	2.72	-
$T_j = +2\text{ °C}$	Pdh	1.7	kW	$T_j = +2\text{ °C}$	COPd	3.22	-
$T_j = +7\text{ °C}$	Pdh	1.7	kW	$T_j = +7\text{ °C}$	COPd	3.37	-
$T_j = +12\text{ °C}$	Pdh	1.7	kW	$T_j = +12\text{ °C}$	COPd	3.28	-
$T_j = \text{biv}$	Pdh	1.7	kW	$T_j = \text{biv}$	COPd	3.04	-
$T_j = \text{TOL}$	Pdh	1.7	kW	$T_j = \text{TOL}$	COPd	2.56	-
$T_j = -15\text{ °C}$ (if TOL < -20 °C)	Pdh		kW	$T_j = -15\text{ °C}$ (if TOL < -20 °C)	COPd		-
Bivalent temperature	$T_{\text{biv}}$	-1.6	°C	Min. outdoor air temperature	TOL	-10	°C
Cycling interval capacity	P <sub>cy</sub>		kW	Cycling interval efficiency	COP <sub>cy</sub>		-
Degradation coefficient	Cdh	0.96	-	Max supply temperature	WTOL	58	°C
<i>Power consumption in modes other than active mode</i>				<i>Additional heat</i>			
Off mode	P <sub>OFF</sub>	0.002	kW	Rated heat output	P <sub>sup</sub>	0.9	kW
Thermostat-off mode	P <sub>TO</sub>	0.02	kW				
Standby mode	P <sub>SB</sub>	0.015	kW	Type of energy input	Electric		
Crankcase heater mode	P <sub>CK</sub>	0	kW				
<i>Other items</i>							
Capacity control	Fixed			Rated airflow (air-water)		150	m <sup>3</sup> /h
Sound power level, indoors/outdoors	L <sub>WA</sub>	52 / -	dB	Nominal heating medium flow		0.18	m <sup>3</sup> /h
Annual energy consumption	Q <sub>HE</sub>	1.806	kWh	Brine flow brine-water or water-water heat pumps			m <sup>3</sup> /h
<i>For heat pump combination heater</i>							
Declared load profile for water heating	L			Water heating energy efficiency	$\eta_{\text{wh}}$	79	%
Daily energy consumption	Q <sub>elec</sub>	5.92	kWh	Daily fuel consumption	Q <sub>fuel</sub>		kWh
Annual energy consumption	AEC	1,299	kWh	Annual fuel consumption	AFC		GJ
Contact information	NIBE Energy Systems - Box 14 - Hannabadsvägen 5 - 285 21 Markaryd - Sweden						

# Electrical circuit diagram

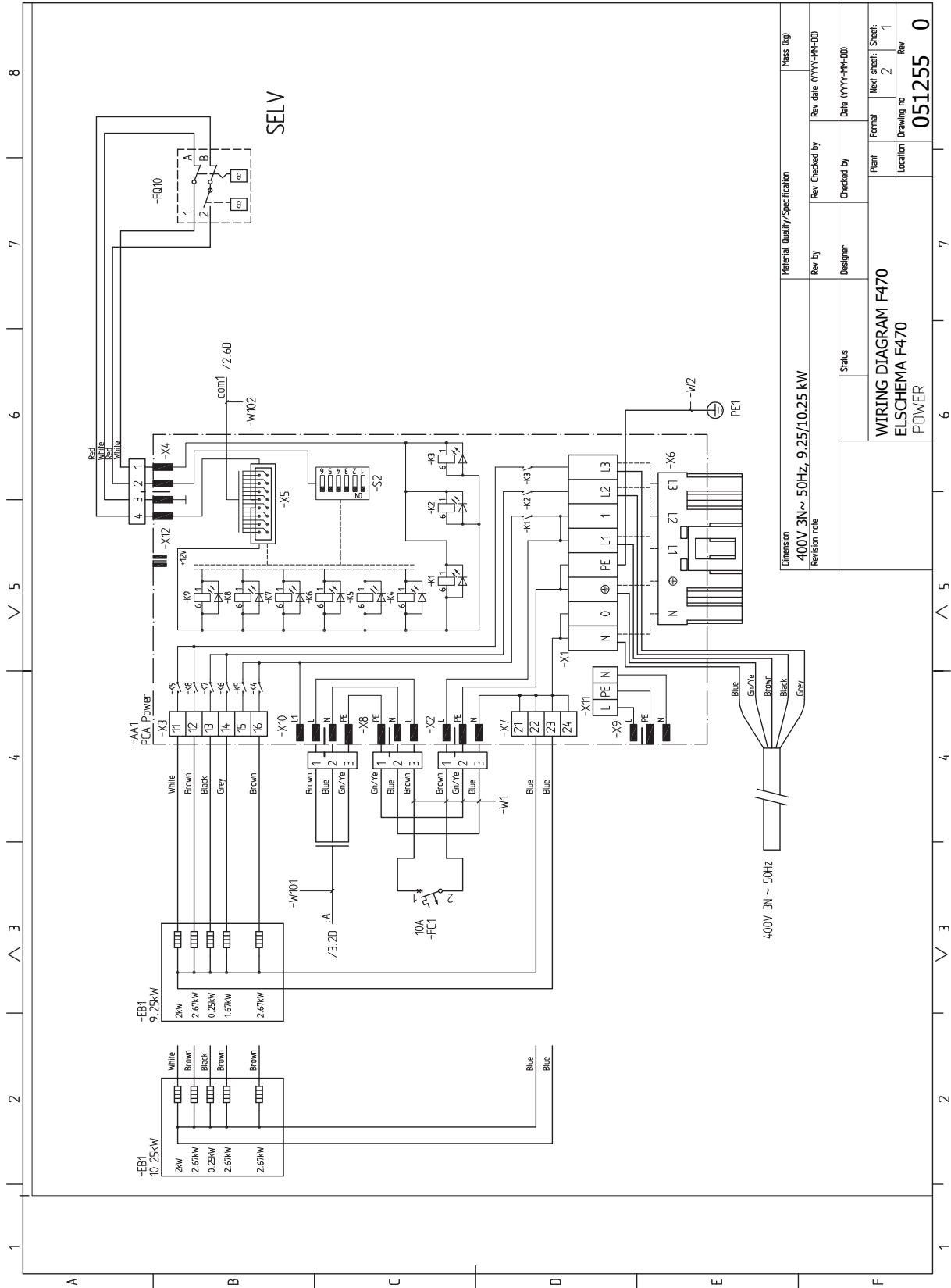

Material Quality/Specification		Mass (kg)	
Dimension	400V 3N~50Hz, 9.25/10.25 kW	Rev checked by	Rev date (YYYY-MM-DD)
Revision note		Designer	Date (YYYY-MM-DD)
Status		Plant	Next sheet: Sheet: 1
		Location	Drawing no
			051255
			0

WIRING DIAGRAM F470  
 ELSHEMA F470  
 POWER

COLOR CODE	
IL/CSA DIN 47700	White
Black	White
Brown	Brown
Red	Green
Orange	Yellow
Yellow	Grey
Green	Blue
Blue	Blue
Violet	Red
Grey	Black
White	Violet

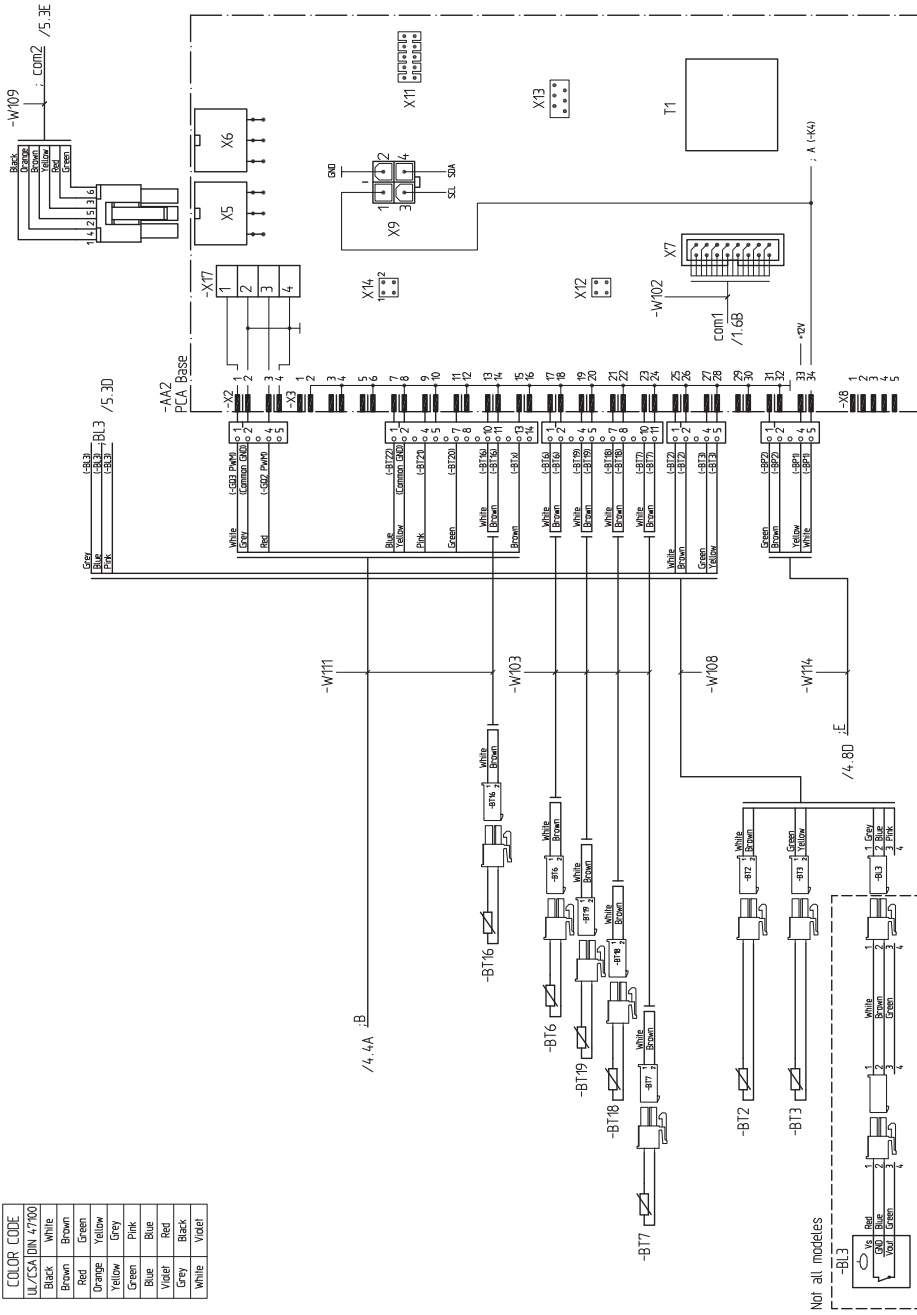

SELV

Dimension	Material Quality/Specification	Mass (kg)
400V 3N ~ 50Hz, 9.25/10.25 kW		
Revision note	Rev by	Rev Checked by
	Designer	Rev date (YYYY-MM-DD)
	Status	Checked by
	Date (YYYY-MM-DD)	
	Plant	Formal
	Location	Next sheet: Sheet:
		3
		2
	Drawing no	Rev
	051255	0

WIRING DIAGRAM F470  
ELSCHEMA F470  
BASE

1 2 3 4 5 6 7 8

A B C D E F

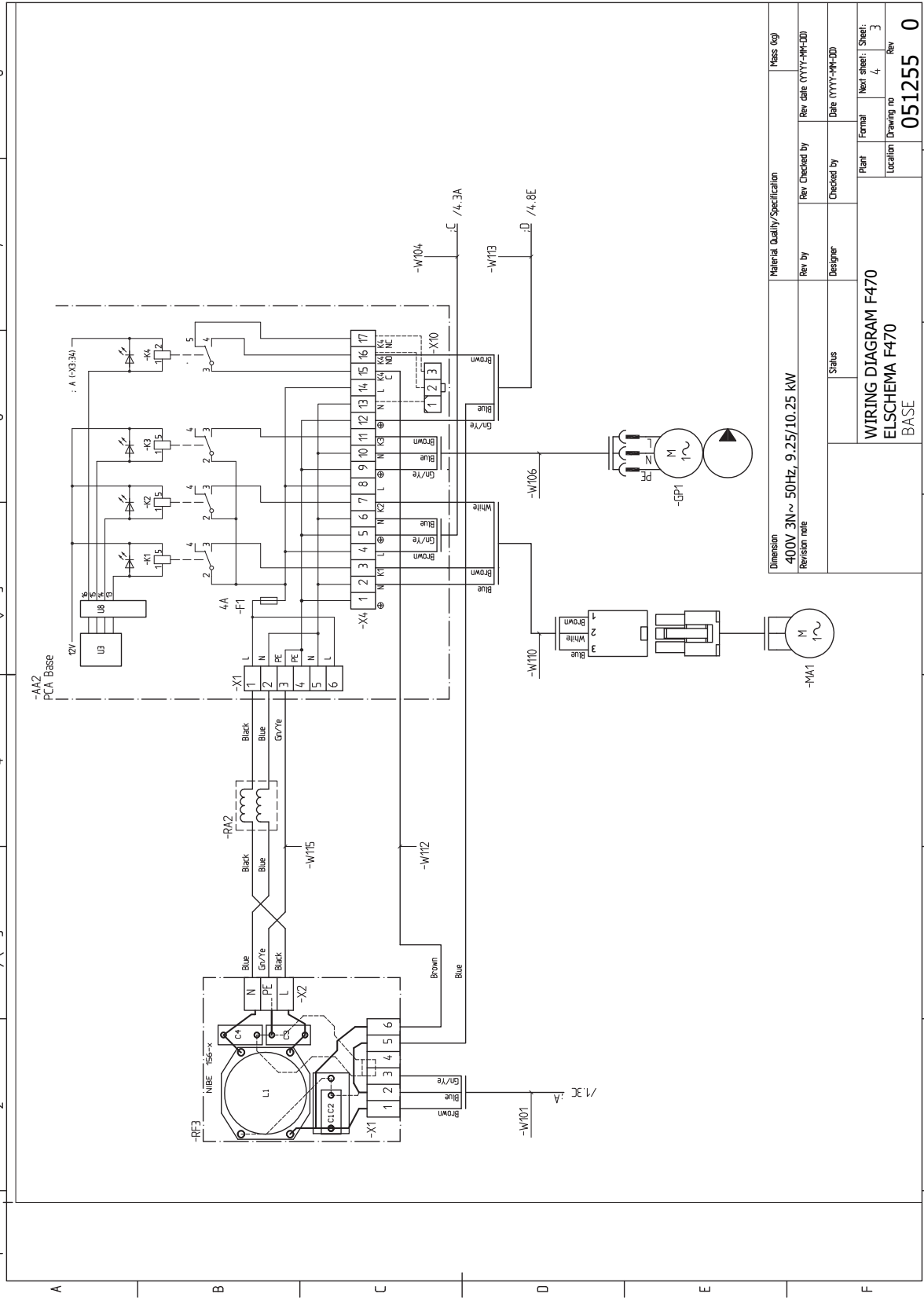

Material Quality/Specification		Mass (kg)	
Dimension	400V 3N~ 50Hz, 9.25/10.25 kW	Rev by	Rev Checked by
Revision note		Status	Designer
		Checked by	Date (YYYY-MM-DD)
		Plant	Formal
		Location	Next sheet: Sheet:
			4
		Drawing no	Rev
			051255
			0



1 2 3 4 5 6 7 8

COLOR CODE	
UL/CSA (DIN 47100)	
Black	White
Brown	Brown
Red	Green
Orange	Yellow
Yellow	Grey
Green	Pink
Blue	Green
Violet	Red
Grey	Black
White	Violet

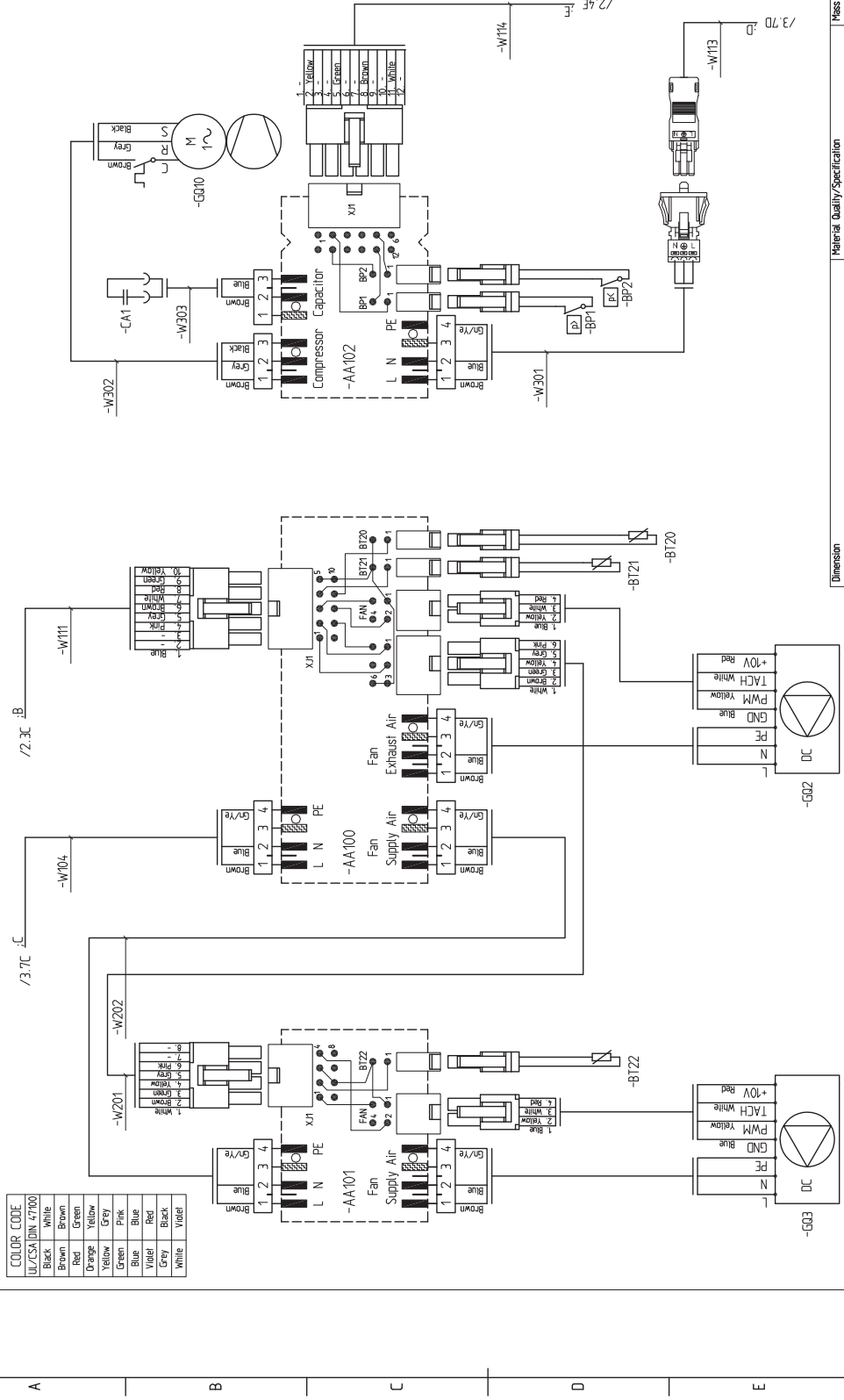

Material Quality/Specification		Rev date (YYYY-MM-DD)	
Dimension	400V 3N~ 50Hz, 9.25/10.25 kW	Rev by	Rev date (YYYY-MM-DD)
Revision note		Designer	Date (YYYY-MM-DD)
		Status	Plant
			Formal
			Next sheet: Sheet:
			Location
			Drawing no
			Rev
			051255
			0

WIRING DIAGRAM F470  
ELSCHEMA F470  
BASE

1 2 3 4 5 6 7 8

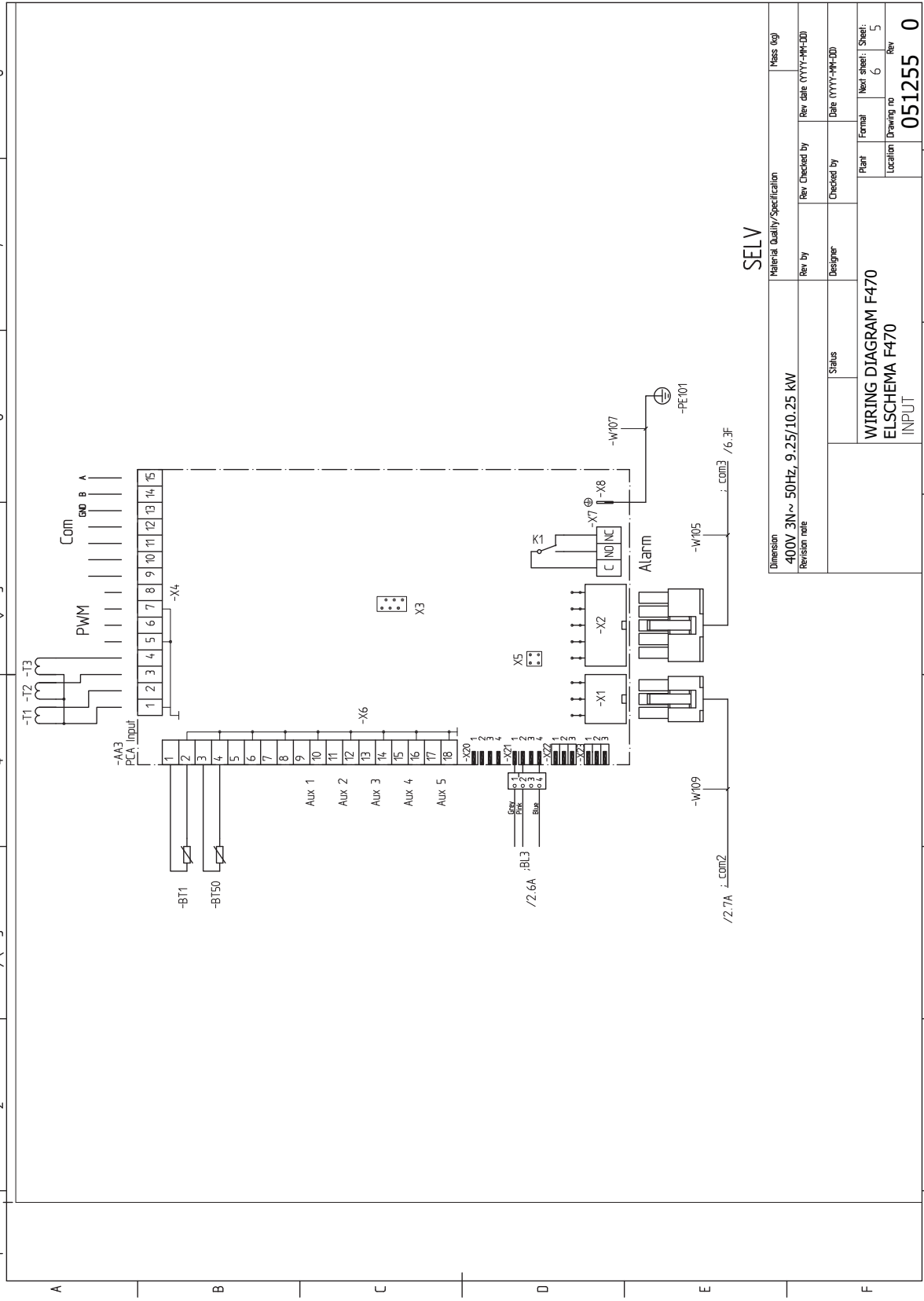

**SELV**

Material Quality/Specification		Mass (kg)	
Dimension	400V 3N~ 50Hz, 9.25/10.25 kW	Rev by	Rev date (YYYY-MM-DD)
Revision note		Designer	Checked by
		Status	Date (YYYY-MM-DD)
		Plant	Formal
		Location	Next sheet: Sheet: 5
		Drawing no	
		Rev	
		051255	
		0	

WIRING DIAGRAM F470  
ELSCHEMA F470  
INPUT

1 2 3 4 5 6 7 8

-AA4  
PCA Display Unit

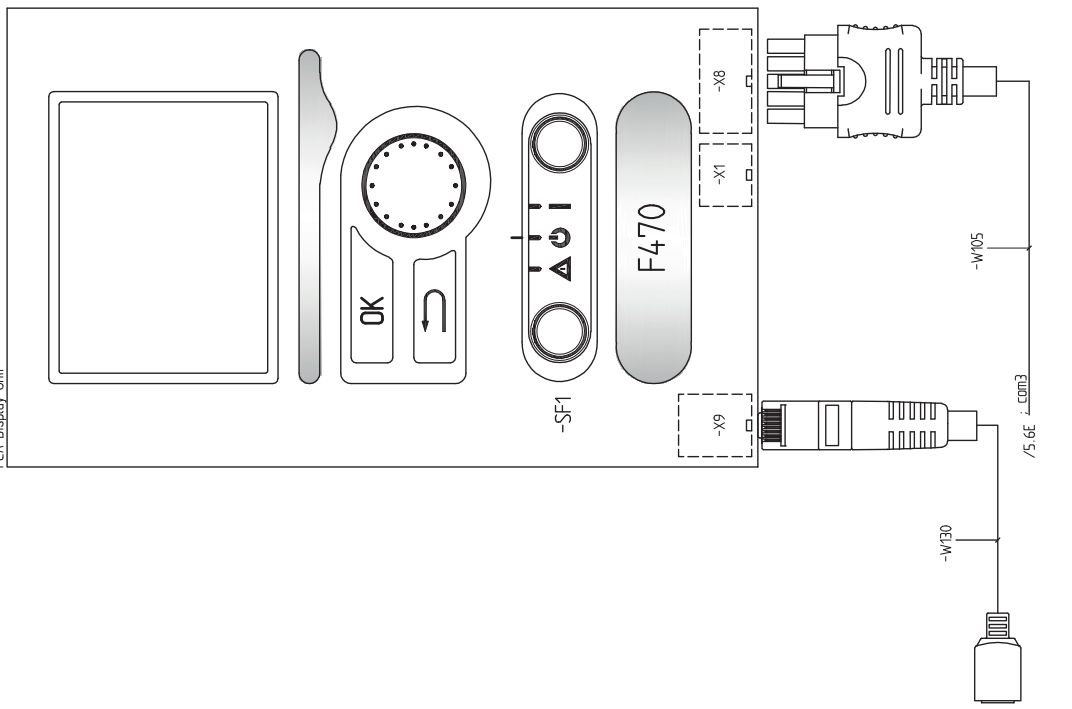

SELV

Material Quality/Specification		Mass (kg)	
Dimension	400V 3N~ 50Hz, 9.25/10.25 kW	Rev. Checked by	Rev. date (YYYY-MM-DD)
Revision note		Checked by	Date (YYYY-MM-DD)
Status		Plant	Formal
Designer		Location	Next sheet: Sheet: 6
WIRING DIAGRAM F470		Drawing no	Rev
ELSHEMA F470			
DISPLAY			
			051255 0

# Item register

## A

Accessibility, electrical connection, 23  
Accessories, 56  
Alarm, 54  
Assembly, 11

## B

Back button, 40

## C

Cable lock, 24  
Climate system, 19  
Cold and hot water  
  Connecting cold and hot water, 19  
Commissioning and adjusting, 31  
  Filling and venting, 31  
  Preparations, 31  
  Start guide, 32  
  Start-up and inspection, 32  
Connecting accessories, 30  
Connecting cold and hot water, 19  
Connecting current sensors, 28  
Connecting external operating voltage for the control system, 25  
Connecting hot water circulation, 20  
Connecting the climate system, 19  
Connections, 25  
Control, 40, 44  
  Control - Introduction, 40  
  Control - Menus, 44  
Control - Introduction, 40  
  Display unit, 40  
  Menu system, 40  
Control knob, 40  
Control - Menus, 44  
  Menu 5 - SERVICE, 46

## D

Delivery and handling, 11  
  Assembly, 11  
  Installation area, 11  
  Removing parts of the insulation, 13  
  Removing the covers, 12  
  Supplied components, 12  
  Transport, 11  
Dimensions and pipe connections, 18  
Dimensions and setting-out coordinates, 57  
Display, 40  
Display unit, 40  
  Back button, 40  
  Control knob, 40  
  Display, 40  
  OK button, 40  
  Status lamp, 40  
  Switch, 40  
Disturbances in comfort, 54  
  Alarm, 54  
  Manage alarm, 54  
  Troubleshooting, 54  
Docking alternatives  
  Two or more climate systems, 20  
Draining the climate system, 50  
Draining the hot water heater, 50

## E

Electrical addition - maximum output, 27  
Electrical circuit diagram, 62  
Electrical connections, 23  
  Accessibility, electrical connection, 23  
  Cable lock, 24  
  Connecting accessories, 30  
  Connecting external operating voltage for the control system, 25  
  Connections, 25  
  Electrical addition - maximum output, 27  
  External connection options, 28  
  Load monitor, 27  
  Miniature circuit-breaker, 23  
  NIBE Uplink, 28  
  Optional connections, 27  
  Outdoor sensor, 26  
  Power connection, 25  
  Removing the cover, base board, 24  
  Removing the cover, immersion heater circuit board, 24  
  Removing the hatch, input circuit board, 24  
  Room sensor, 26  
  Settings, 27  
  Standby mode, 27  
  Temperature limiter, 23  
Energy labelling, 60  
  Data for energy efficiency of the package, 60  
  Information sheet, 60  
  Technical documentation, 61  
Exhaust air duct, 21  
External connection options, 28  
  Possible selection for AUX inputs, 29

## F

Filling and venting, 31  
  Filling the climate system, 31  
  Filling the hot water heater, 31  
  Venting the climate system, 31  
Filling the climate system, 31  
Filling the hot water heater, 31

## H

Handling, 4  
Helping the circulation pump to start, 50  
Help menu, 43

## I

Important information, 4  
  Recovery, 9  
Inspection of the installation, 10  
Installation alternative  
  Connecting hot water circulation, 20  
  Water heater with immersion heater, 20  
Installation area, 11

## M

Manage alarm, 54  
Marking, 4  
Menu 5 - SERVICE, 46  
Menu system, 40  
  Help menu, 43  
  Operation, 42  
  Scroll through the windows, 43  
  Selecting menu, 42  
  Selecting options, 42

- Setting a value, 42
- Use the virtual keyboard, 43
- Miniature circuit-breaker, 23
- N**
- NIBE Uplink, 28
- O**
- OK button, 40
- Operation, 42
- Optional connections, 27
- Outdoor sensor, 26
- P**
- Pipe and ventilation connections, 17
  - Climate system, 19
  - Cold and hot water
    - Connecting cold and hot water, 19
  - Connecting the climate system, 19
  - Dimensions and pipe connections, 18
  - Exhaust air duct, 21
  - General pipe connections, 17
  - Maximum boiler and radiator volumes, 17
  - Pipe dimensions, 18
  - Setting out dimensions, 18
  - Supply air battery, 19
  - Symbol key, 19
- Pipe dimensions, 18
- Possible selection for AUX inputs, 29
- Power connection, 25
- Preparations, 31
- R**
- Remove parts of the insulation, 13
- Removing the cover, base board, 24
- Removing the cover, immersion heater circuit board, 24
- Removing the covers, 12
- Removing the hatch, input circuit board, 24
- Room sensor, 26
- S**
- Safety information
  - Handling, 4
  - Inspection of the installation, 10
  - Marking, 4
  - Safety precautions, 5
  - Serial number, 9
  - Symbols, 4
- Safety precautions, 5
  - Collection, 8
  - Decommissioning, 8
  - Filling, 7
  - Leak testing, 6
  - Marking, 8
  - Removal and draining, 7
  - Repairing sealed components, 6
  - When working in the refrigerant circuit, 9
  - Wiring, 6
- Scroll through the windows, 43
- Selecting menu, 42
- Selecting options, 42
- Serial number, 9
- Service, 50
  - Service actions, 50
- Service actions, 50
  - Draining the climate system, 50
  - Draining the hot water heater, 50
  - Helping the circulation pump to start, 50
  - Standby mode, 50
  - Temperature sensor data, 51
- USB service outlet, 52
- Setting a value, 42
- Setting out dimensions, 18
- Settings, 27
- Standby mode, 50
  - Power in emergency mode, 27
- Start guide, 32
- Start-up and inspection, 32
  - Commissioning without fans, 34
  - Setting the pump speed, 35
  - Setting the ventilation, 33
  - Supply air battery, 34
- Status lamp, 40
- Supplied components, 12
- Supply air battery, 19
- Switch, 40
- Symbol key, 19
- Symbols, 4
- T**
- Technical data, 57
  - Dimensions and setting-out coordinates, 57
  - Electrical circuit diagram, 62
  - Technical Data, 58
- Technical Data, 58
- Temperature limiter, 23
  - Resetting, 23
- Temperature sensor data, 51
- The heat pump design, 14
- Transport, 11
- Troubleshooting, 54
- U**
- USB service outlet, 52
- Use the virtual keyboard, 43
- V**
- Venting the climate system, 31



## Contact information

### **AUSTRIA**

KNV Energietechnik GmbH  
Gahberggasse 11, 4861 Schörfling  
Tel: +43 (0)7662 8963-0  
mail@knv.at  
knv.at

### **FINLAND**

NIBE Energy Systems Oy  
Juurakkotie 3, 01510 Vantaa  
Tel: +358 (0)9 274 6970  
info@nibe.fi  
nibe.fi

### **GREAT BRITAIN**

NIBE Energy Systems Ltd  
3C Broom Business Park,  
Bridge Way, S41 9QG Chesterfield  
Tel: +44 (0)330 311 2201  
info@nibe.co.uk  
nibe.co.uk

### **POLAND**

NIBE-BIAWAR Sp. z o.o.  
Al. Jana Pawla II 57, 15-703 Bialystok  
Tel: +48 (0)85 66 28 490  
biawar.com.pl

### **CZECH REPUBLIC**

Družstevní závody Dražice - strojírna  
s.r.o.  
Dražice 69, 29471 Benátky n. Jiz.  
Tel: +420 326 373 801  
nibe@nibe.cz  
nibe.cz

### **FRANCE**

NIBE Energy Systems France SAS  
Zone industrielle RD 28  
Rue du Pou du Ciel, 01600 Reyrieux  
Tél: 04 74 00 92 92  
info@nibe.fr  
nibe.fr

### **NETHERLANDS**

NIBE Energietechnik B.V.  
Energieweg 31, 4906 CG Oosterhout  
Tel: +31 (0)168 47 77 22  
info@nibenl.nl  
nibenl.nl

### **SWEDEN**

NIBE Energy Systems  
Box 14  
Hannabadsvägen 5, 285 21 Markaryd  
Tel: +46 (0)433-27 30 00  
info@nibe.se  
nibe.se

### **DENMARK**

Vølund Varmeteknik A/S  
Industrivej Nord 7B, 7400 Herning  
Tel: +45 97 17 20 33  
info@volundvt.dk  
volundvt.dk

### **GERMANY**

NIBE Systemtechnik GmbH  
Am Reiherpfahl 3, 29223 Celle  
Tel: +49 (0)5141 75 46 -0  
info@nibe.de  
nibe.de

### **NORWAY**

ABK-Qviller AS  
Brobekkeveien 80, 0582 Oslo  
Tel: (+47) 23 17 05 20  
post@abkqviller.no  
nibe.no

### **SWITZERLAND**

NIBE Wärmetechnik c/o ait Schweiz AG  
Industriepark, CH-6246 Altishofen  
Tel. +41 (0)58 252 21 00  
info@nibe.ch  
nibe.ch

For countries not mentioned in this list, contact NIBE Sweden or check [nibe.eu](http://nibe.eu) for more information.

NIBE Energy Systems  
Hannabadsvägen 5  
Box 14  
SE-285 21 Markaryd  
info@nibe.se  
nibe.eu

IHB EN 2340-1 831035

This is a publication from NIBE Energy Systems. All product illustrations, facts and data are based on the available information at the time of the publication's approval.

NIBE Energy Systems makes reservations for any factual or printing errors in this publication.

©2023 NIBE ENERGY SYSTEMS

