



Air/water heat pump

NIBE F2050

NIBE F2050 is an intelligent, compact and inverter-controlled air/water heat pump with climate-friendly refrigerant. NIBE F2050 provides optimised savings since the heat pump automatically adapts to your home's output requirements all year round.

The heat pump works down to an outdoor temperature of -20°C and at the same time supplies up to 58°C in supply line temperature. The effective cooling function allows the heat pump to deliver a comfortable indoor climate even at high outdoor temperatures. It also has a climate-friendly refrigerant to provide less impact on the environment. Available in two sizes F2050-6 and F2050-10.

Thanks to smart technology, the product gives you control over your energy consumption and will be a key part of your connected home. The efficient control system automatically adjusts the indoor climate for high comfort, and you do nature a favour at the same time.



- **Compact heat pump that adapts to your home's requirements.**
- **High capacity even down to -20°C and effective cooling function.**
- **Energy-saving smart technology with user-friendly control.**

This is how NIBE F2050 works

Installation method

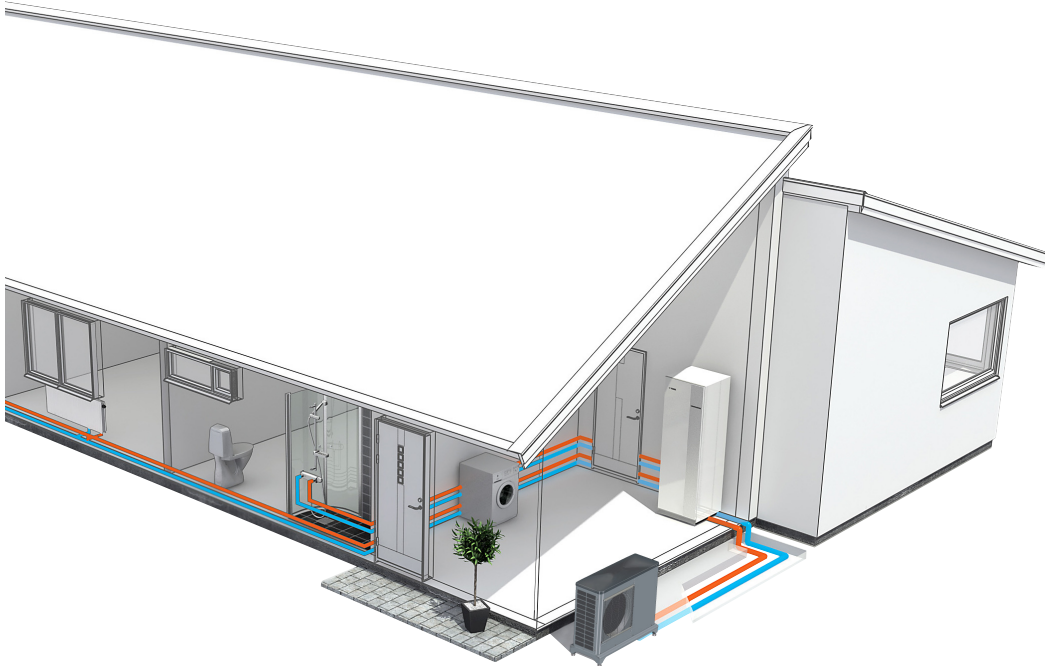

F2050 – a part of your climate system where F2050 is intended to be combined with one of the indoor modules or the control modules.

Together with an indoor module, F2050 creates a complete heating/cooling and hot water system. Our flexible indoor modules provide efficient heating and high hot water performance. Indoor modules are complete with a smart, user-friendly control system, hot water heater, additional heat, self-regulating circulation pump, etc.

The control modules offer a flexible system solution that can be easily customised. For systems with a control module, different components, such as water heaters, additional heat and other accessories, can be selected to suit the installation's requirements.

There is a wide range of system solutions and accessories for NIBE's indoor modules and control modules.

PRINCIPLE OF OPERATION

Principle of operation with hot water and heating system.

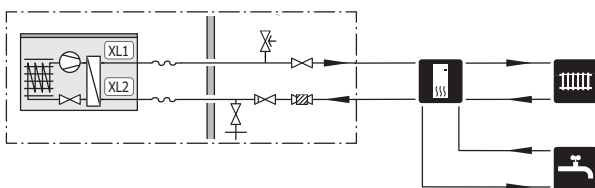

- XL1 Heating medium connection, supply (from F2050)
- XL2 Heating medium connection, return (to F2050)

COMPATIBLE INDOOR MODULES AND CONTROL MODULES

	SMO S40	VVM S320	VVM S330
F2050-6	X	X	X
F2050-10	X	X	X

	VVM 225	VVM 310	VVM 500	SMO 20	SMO 40	MHB 05
F2050-6	X	X	X	X	X	X
F2050-10	X	X	X	X	X	X

INDOOR MODULES



VVM S320

Stainless steel, 3x230 V
Part no. 069 201

VVM S320

Stainless steel, 3x400 V
Part no. 069 196

VVM S330

Stainless steel, 3 x 400 V
Part no. 069 250



VVM 225

Enamel (DK), 3x400 V
Part no. 069 228

VVM 225

Stainless steel, 3x400 V
Part no. 069 229

VVM 310

Stainless steel, 3x400 V
With integrated EMK 310
Part no. 069 084

VVM S320

Enamel, 3x400 V
Part no. 069 206

VVM S330

Stainless steel, 1 x 230 V
Part no. 069 249

VVM 225

Enamel, 3x400 V
Part no. 069 227

VVM 310

Stainless steel, 3x400 V
Part no. 069 430

VVM 500

Stainless steel, 3x400 V
Part no. 069 400

HYDROBOX

MHB 05

Part no. 067 942

CONTROL MODULES

SMO S40

Control module
Part no. 067 654

SMO 20

Control module
Part no. 067 224

SMO 40

Control module
Part no. 067 225



Good to know about NIBE F2050

Transport

F2050 should be transported and stored vertically in a dry place.

Ensure that the heat pump cannot fall over during transport.

Check that F2050 has not been damaged during transport.

LIFT FROM THE STREET TO THE SET UP LOCATION

If the surface allows, the easiest method is to use a pallet truck to move the heat pump to the installation area.

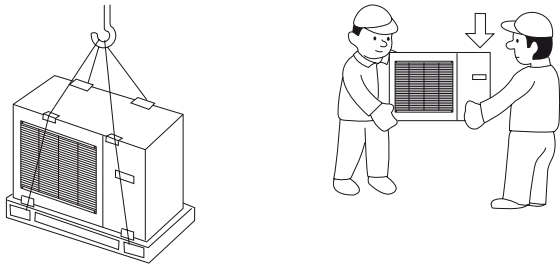

If the heat pump needs to be transported across soft ground, such as a lawn, we recommend using a crane truck that can lift it to the installation location. When the heat pump is lifted with a crane, the packaging must be intact.

If a crane truck cannot be used, the heat pump can be transported on an extended sack truck. The heat pump must be taken hold of from its heaviest side and two people are required to lift it.

LIFT FROM THE PALLET TO FINAL POSITIONING

Before lifting remove the packaging and the securing strap to the pallet.

Place lifting straps around each foot. It is recommended that two people perform the lift from the pallet to the base.

Installation and positioning

- Place the heat pump in a suitable location outdoors to prevent any risk of the refrigerant flowing in through ventilation openings, doors or similar openings in the event of a leak. It must also not constitute a hazard to people or property in any other way.
- If the heat pump is placed in a location where any refrigerant leak could accumulate, for example below ground level (in a dip or low-lying recess), the installation must satisfy the same requirements that apply for gas detection and the ventilation of engineering rooms. Requirements regarding sources of ignition must be applied where appropriate.
- Place F2050 outdoors on a solid level base that can take the weight, preferably a concrete foundation. If concrete slabs are used they must rest on asphalt or shingle.

- The lower edge of the evaporator must not be lower than the level of the average local snow depth, or at least 300 mm above ground level. The base should be at least 70 mm tall.
- F2050 should not be positioned next to noise sensitive walls, for example, next to a bedroom.
- Also ensure that the placement does not inconvenience the neighbours.
- F2050 must not be placed so that recirculation of the outdoor air is possible. Recirculation entails reduced power and impaired efficiency.
- The evaporator must be sheltered from direct wind / , which negatively affects the defrosting function. Place F2050 protected from wind / against the evaporator.
- Large amounts of condensation, as well as melt water from defrosting, may be produced. Use the accessory KVR 10, see section "Condensate drip tray".
- Care must be exercised so that the heat pump is not scratched during installation.

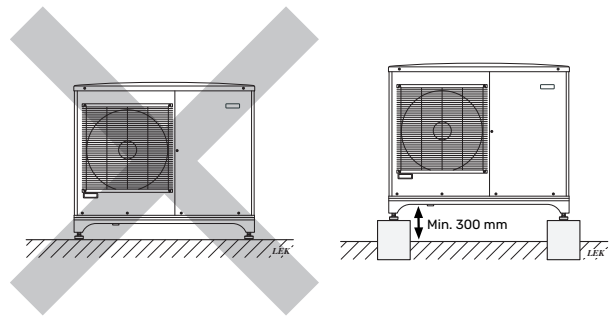

Do not place F2050 directly on the lawn or other non solid surface.

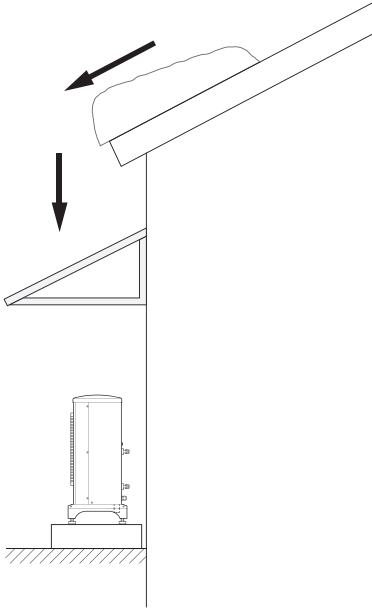

If there is a risk of snow slip from roof, a protective roof or cover must be erected to protect the heat pump, pipes and wiring.

Supplied components

Local differences in the enclosed kit may occur. See relevant installer manual for more information.

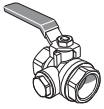

1 x filterball (G1")

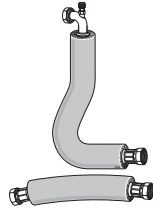

2 x flexible pipes (DN25, G1")
with 4 x gaskets

Installation area

The distance between F2050 and the house wall must be at least 150 mm, but not more than 500 mm in locations that are exposed to the wind. The free space above F2050 must be at least 1,000 mm. The free space in front must be at least 1,000 mm for any future servicing.

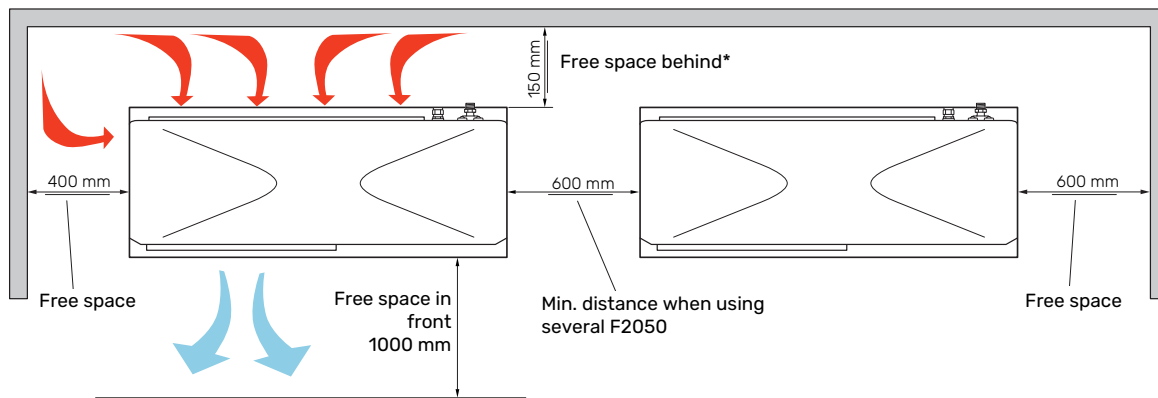

* The space behind must not exceed 500 mm in locations that are exposed to the wind.

Installation

Inspection of the installation

Current regulations require the heating installation to be inspected before it is commissioned. The inspection must be carried out by a suitably qualified person and should be documented. The above applies to closed heating systems.

If the heat pump is replaced, the installation must be inspected again.

Condensation water trough

The condensate drain pan collects and leads away the condensation water.

It is important to the heat pump function that condensation water is led away and that the drain for the condensation water run off is not positioned so that it can cause damage to the house.

Condensation run-off should be checked regularly, especially during the autumn. Clean if necessary.

Pipe, with heating cable, for draining the condensate drip tray is not included. To guarantee the function, the accessory KVR should be used.

- The condensation water (up to 50 litres / 24 hrs) must be routed away by a pipe to an appropriate drain, it is recommended that the shortest outdoor length possible is used.
- The section of the pipe that can be affected by frost must be heated by the heating cable to prevent freezing.

Pipe with heating cable for draining the condensation water trough is not included.

To ensure this function, the accessory KVR should be used.

- Route the pipe downward from the heat pump.
- The outlet of the condensation water pipe must be at frost free depth.
- Use a water trap for installations where air circulation may occur in the condensation water pipe.
- The insulation must seal against the bottom of the condensation water trough.

DRAIN PAN HEATER, CONTROL

The drain pan heater is supplied with power when one of the following conditions is met:

1. The compressor has been in operation for at least 30 minutes after last start.
2. The ambient temperature is lower than 1 °C.

DRAINAGE OF CONDENSATION

If none of the following recommended alternatives is used, good drainage of condensation must be provided.

Stone caisson

If the house has a cellar the stone caisson must be positioned so that condensation water does not affect the house. Otherwise the stone caisson can be positioned directly under the heat pump.

Gutter drainage

Route the pipe sloping downward from the heat pump. The condensation water pipe must have a water seal to prevent air circulation in the pipe.

Pipe connections

MINIMUM SYSTEM FLOWS

An undersized climate system can result in damage to the product and lead to malfunctions.

Each climate system must be dimensioned individually to provide the recommended system flows.

The installation must be dimensioned to provide at least the minimum defrosting flow at 100 % circulation pump operation.

Air/water heat pump	Minimum flow during defrosting 100% circulation pump operation (l/s)	Minimum recommended pipe dimension (DN)	Minimum recommended pipe dimension (mm)
F2050-6	0.19	20	22
F2050-10			

F2050 can only operate up to a return temperature of about 55 °C and an outgoing temperature of about 58 °C from the heat pump.

WATER VOLUMES

When docking with F2050 free flow in the climate system is recommended for correct heat transfer. This can be achieved by use of a bypass valve. If free flow cannot be ensured, it is recommended that a buffer tank (NIBE UKV) is installed.

Following water volumes are recommended

F2050	-6	-10
Minimum volume, climate system during heating/cooling	20 l	50 l
Minimum volume, climate system during under floor cooling	50 l	80 l

CHARGE PUMP

The charge pump (not included in the product) is powered and controlled from the indoor module/control module. It has a built-in frost protection function and, for this reason, must not be switched off when there is a risk of freezing.

At temperatures below +2 °C the charge pump runs periodically, to prevent the water from freezing in the charge circuit. The function also protects against excess temperatures in the charge circuit.

PRESSURE DROP, HEATING MEDIUM SIDE

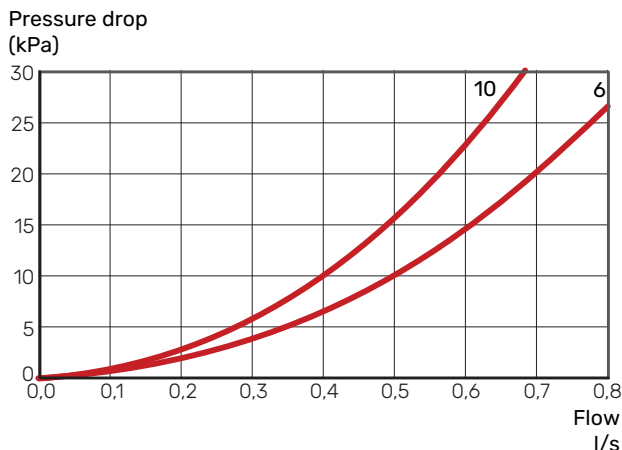

INSTALLATION ALTERNATIVE

F2050 can be connected in several ways. The necessary safety equipment must be installed in accordance with current regulations for all installation options.

See nibe.eu for more detailed installation options.

Electrical connections

- Electrical installation and wiring must be carried out in accordance with national provisions.
- If a miniature circuit breaker is used, this must have at least triggering characteristic "C". See section "Technical specifications" in the Installer Manual for F2050.
- If the building is equipped with an RCD, F2050 must be equipped with a separate one.
- F2050 must be installed via an isolator switch. The cable area has to be dimensioned based on the fuse rating used.
- The RCD should have a nominal tripping current of no more than 30 mA. The incoming supply must be 230V-50Hz via an electrical distribution unit with fuses.
- The routing of cables for heavy current and signals should be made out through the cable glands on the heat pump's right-hand side, seen from the front.
- The communication cable must be a screened cable with three conductors.
- Connect the charge pump to the control module. See where the charge pump is to be connected in the Installer Manual for your control module.

Functions

When connection to NIBE indoor module / control module (VVM / SMO) is ready, you can control your unit via the indoor module / control module.

Control, general

The indoor temperature depends on several different factors. Sunlight and heat emissions from people and household machines are normally sufficient to keep the house warm during the warm seasons. When it gets colder outside, the climate system needs to help heat the house. The colder it is outside, the warmer radiators and underfloor heating systems have to be.

Control of the heat production is performed based on the "floating condensing" principle, which means that the temperature level needed for heating at a specific outdoor temperature is produced based on collected values from the outdoor and supply temperature sensors. The room sensor can also be used to compensate the deviation in room temperature.

Heat production



The supply of heat to the house is regulated in accordance with the selected heating curve setting. After adjustment, the correct amount of heat for the current outdoor temperature is supplied. The

supply temperature will oscillate around the theoretically desired value.

OWN CURVE

The indoor module/control module have pre-programmed, non-linear heating curves. It is also possible to create your own defined curve. This is a partially linear curve with a number of break points. You select break points and the associated temperatures.

Hot water production



Hot water charging starts when the temperature has fallen to the set start temperature. Hot water charging stops when the hot water temperature at the hot water sensor has been reached.

For temporary higher hot water demand, there is a function that allows the temperature to be raised temporarily for up to 12 hours or by a one time increase (can be selected in the menu system).

It is also possible to put the installation in holiday mode, which means that the lowest possible temperature is maintained without the risk of freezing.

Additional heat only



The indoor module, which is connected to F2050, can be used with the additional heat alone (electric boiler) to produce heating and hot water, for example before the outdoor unit is installed.

Alarm indications



If there is an alarm, the status lamp lights up red on the indoor module's / control module's display. Detailed information, depending on the fault, is shown in the display. An alarm log is created for each alarm, containing a number of temperatures, times and operating status.

The display



The indoor module / control module (HWM / SMO) is controlled using a clear and easy-to-use display.

Instructions, settings and operational information are shown on the display. You can easily navigate between the different menus and options to set the comfort or obtain the information you require.

Visit myuplink.com and click the "Software" tab to download the latest software for your installation.

Technical data

Dimensions

F2050-6

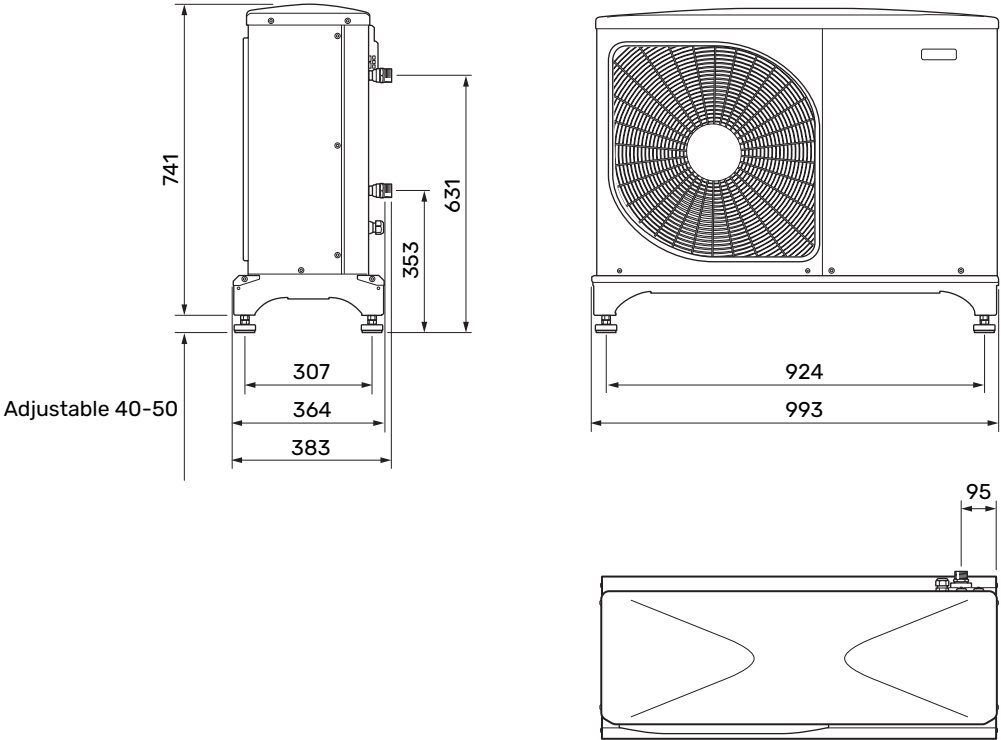

F2050-10

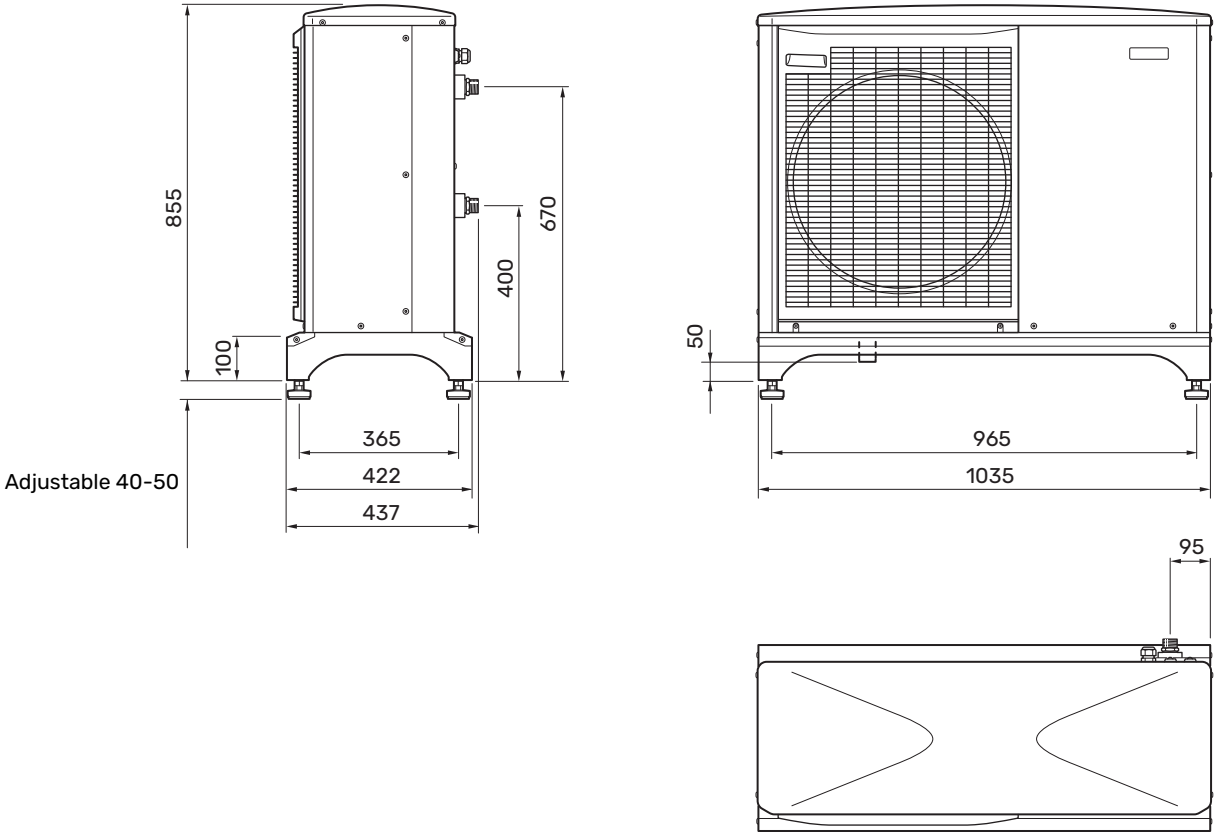

Sound levels

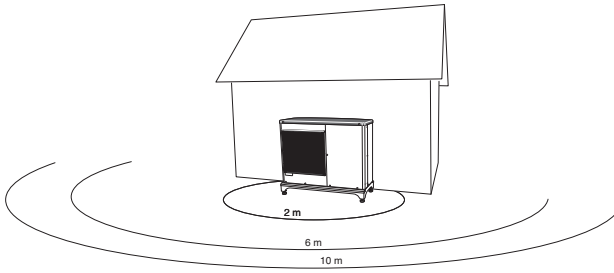

F2050 is usually placed next to a house wall, which gives a directed sound distribution that has to be taken into consideration. Accordingly, when setting up, you should always attempt to select the side that faces the least sound-sensitive neighbouring area.

The sound pressure levels are further affected by walls, bricks, differences in ground level, etc and should therefore only be seen as guide values.

F2050 adjusts the fan speed depending on the ambient temperature and evaporation temperature.

		Sound power ¹	Sound pressure at distance (m) ²									
			1	2	3	4	5	6	7	8	9	10
F2050-6	Nominal sound value	53	48.0	42.0	38.5	36.0	34.0	32.5	31.1	30.0	28.9	28.0
	Max. sound value	62	57.0	51.0	47.5	45.0	43.0	41.5	40.1	39.0	37.9	37.0
	Max. sound value, silent mode	53	48.0	42.0	38.5	36.0	34.0	32.5	31.1	30.0	28.9	28.0
F2050-10	Nominal sound value	53	48.0	42.0	38.5	36.0	34.0	32.5	31.1	30.0	28.9	28.0
	Max. sound value	65	60.0	54.0	50.5	48.0	46.0	44.5	43.1	42.0	40.9	40.0
	Max. sound value, silent mode 60 Hz	53	48.0	42.0	38.5	36.0	34.0	32.5	31.1	30.0	28.9	28.0

¹ Sound power level, $L_w(A)$, according to EN12102

² Sound pressure calculated according to directivity factor $Q=4$

Technical specifications

WORKING RANGE, HEATING

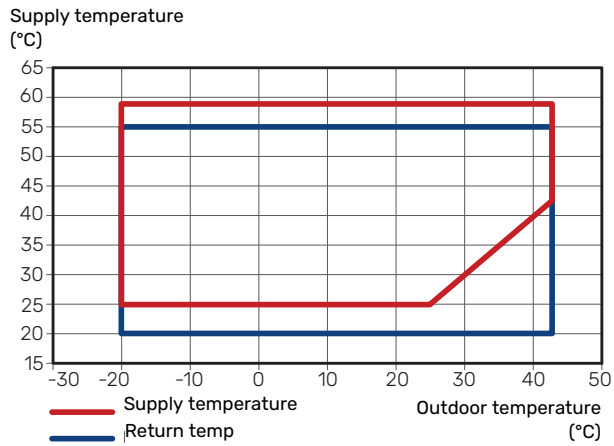

The supply temperature is permitted to be lower for a short period, e.g. at start-up.

WORKING RANGE, COOLING

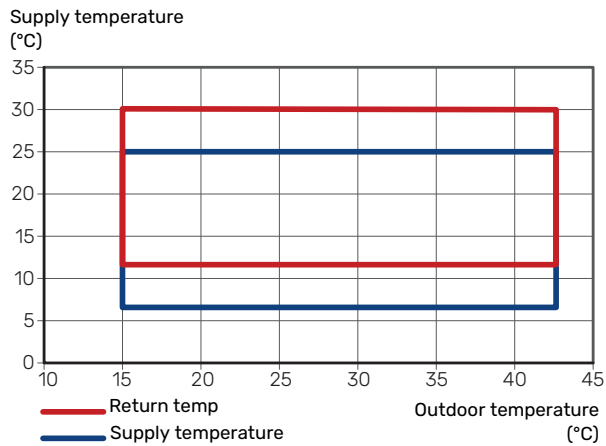

CAPACITY AND COP

Power and COP at different supply temperatures during continuous operation (excluding defrosting).

Power during heating operation

Maximum and minimum capacity during continuous operation.

F2050-6

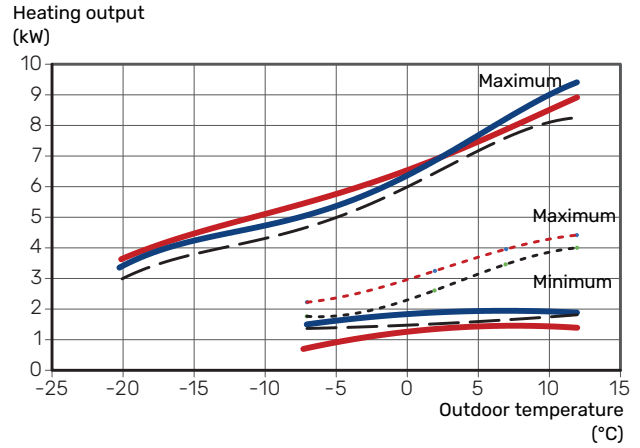

F2050-10

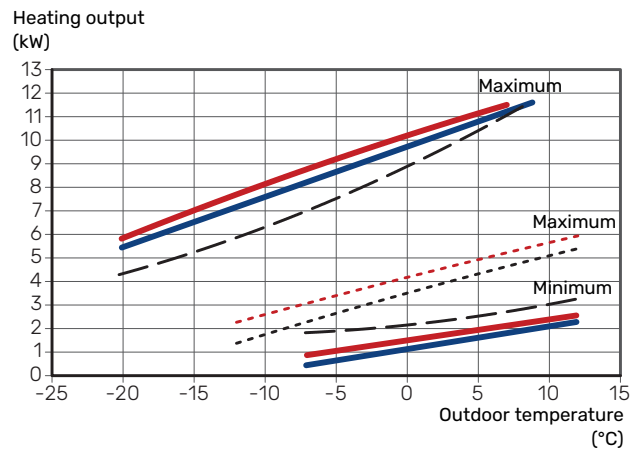

Power during cooling operation

Maximum and minimum capacity during continuous operation.

F2050-6

Cooling output (kW)

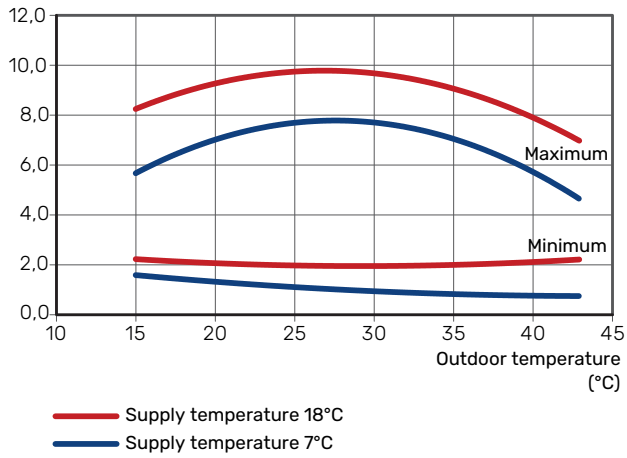

COP during heating operation

F2050-6

COP

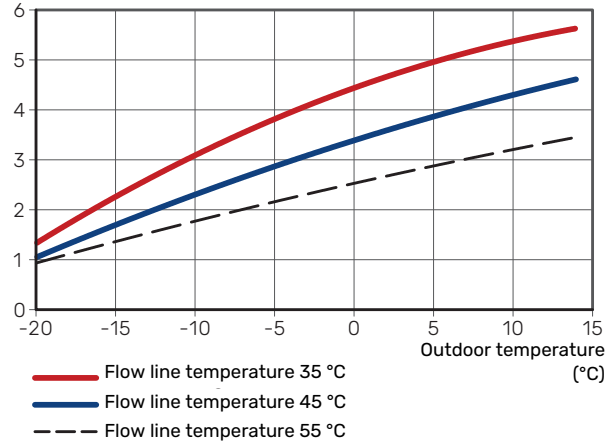

F2050-10

Cooling output (kW)

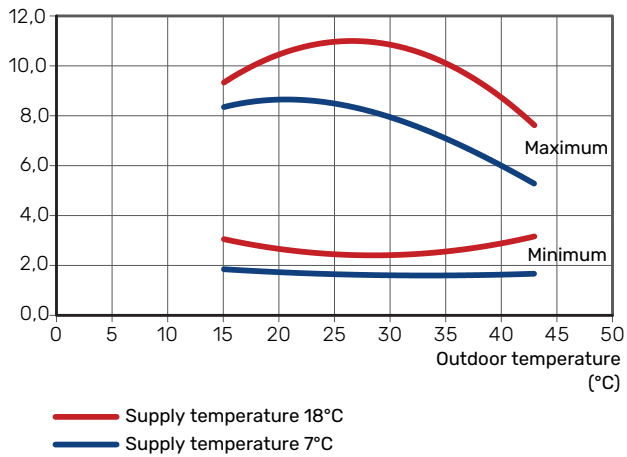

F2050-10

COP

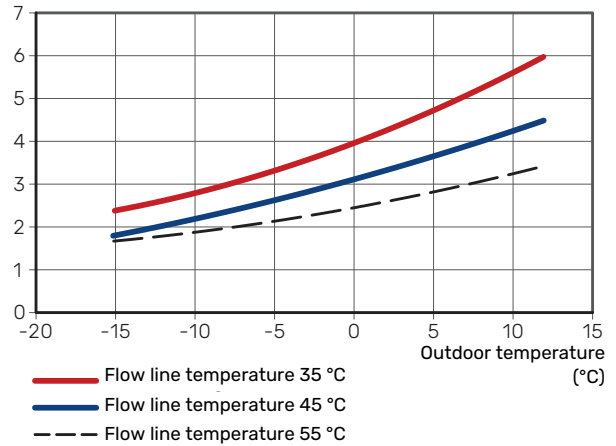

F2050		6	10
Output data according to EN 14 511, partial load¹			
Heating	-7 / 35 °C	5.55 / 2.05 / 2.71	7.18 / 2.93 / 2.45
Capacity / power input / COP (kW/kW/-) at nominal flow	2 / 35 °C	2.31 / 0.56 / 4.13	3.46 / 0.83 / 4.17
Outdoor temp: / Supply temp.	2 / 45 °C	2.02 / 0.67 / 3.01	3.24 / 1.12 / 3.24
	7 / 35 °C	2.65 / 0.49 / 5.41	4.00 / 0.75 / 5.33
	7 / 45 °C	2.43 / 0.65 / 3.74	5.00 / 1.28 / 3.91
Cooling	35 / 7 °C	5.32 / 1.94 / 2.74	7.07 / 2.40 / 2.95
Capacity / power input / EER (kW/kW/-) at maximum flow	35 / 18 °C	7.55 / 2.11 / 3.58	10.79 / 3.00 / 3.60
Outdoor temp: / Supply temp.			
SCOP according to EN 14825			
Nominal heat output (P _{designh}) average climate 35 °C / 55 °C (Europe)	kW	5.20 / 5.60	6.3 / 6.5
Nominal heat output (P _{designh}) cold climate 35 °C / 55 °C	kW	5.80 / 5.70	6.5 / 6.2
Nominal heat output (P _{designh}) warm climate 35 °C / 55 °C	kW	5.57 / 5.48	6.9 / 6.6
SCOP average climate, 35 °C / 55 °C (Europe)		5.08 / 3.58	4.6 / 3.4
SCOP cold climate, 35 °C / 55 °C		4.10 / 3.05	3.9 / 2.9
SCOP warm climate, 35 °C / 55 °C		6.76 / 4.55	6.4 / 4.4
Energy rating, average climate²			
The product's room heating efficiency class 35 °C / 55 °C ³		A+++ / A++	A++ / A++
The system's room heating efficiency class 35 °C / 55 °C ⁴		A+++ / A++	
Electrical data			
Rated voltage		230 V ~ 50 Hz, 230 V 2 ~ 50 Hz	
Max. power, fan	W	50	86
Fuse	A _{rms}	16	16
Enclosure class		IP24	
Refrigerant circuit			
Type of refrigerant		R32	
GWP refrigerant		675	
Volume	kg	1.3	1.84
Type of compressor		Twin Rotary	
CO ₂ -equivalent (The cooling circuit is hermetically sealed.)	t	0.88	1.24
Airflow			
Max airflow	m ³ /h	2,530	3,000
Working area			
Min./max. air temperature, heating	°C	-20 / 43	-20 / 43
Min./max. air temperature, cooling	°C	15 / 43	
Heating medium circuit			
Max system pressure heating medium	MPa (bar)	0.6 (6.0)	
Recommended flow interval, heating operation	l/s	0.08 - 0.32	0.12 - 0.38
Recommended flow interval, cooling operation	l/s	0.11 - 0.29	0.15 - 0.38
Min. design flow, defrosting (100% pump speed)	l/s	0.19	
Min./max. HM temp, continuous operation	°C	25 / 58	
Connection heating medium F2050 external thread		G1 (Ø28 mm)	
Connection heating medium flex pipe		G1 (Ø28 mm)	
Min. recommended pipe dimension (system)	DN (mm)	20 (22)	
Dimensions and weight			
Width	mm	993	1,035
Depth	mm	383	422
Height (with stand)	mm	781 (+10/-0)	895 (+10/-0)
Net weight	kg	76	83
Miscellaneous			
Part no.		064 328	064 318

¹ Power statements including defrosting according to EN 14511 at heating medium supply corresponding to DT=5 K at 7 / 45.

² Reported efficiency for the system also takes the temperature regulator into account. If the system is supplemented with an external auxiliary boiler or solar heating, the total efficiency of the system must be recalculated.

³ Scale for the product's room heating efficiency class A++ to G. Control module model SMO S

⁴ Scale for the system's room heating efficiency class A+++ to G. Control module model SMO S

Accessories

Detailed information about the accessories and complete accessories list available at nibe.eu.

Not all accessories are available on all markets.

Condensation water pipe KVR

Condensation water pipe, different lengths.

KVR 10-10

1 metres

Part no. 067 614

KVR 10-30

3 metres

Part no. 067 616

KVR 10-60

6 metres

Part no. 067 618



Stand and brackets

Ground stand GSU 30

F2050-6, -10

Part no. 067 653

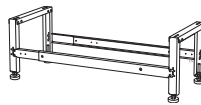

Wall bracket BAU 30

For wall mounting F2050-6, -10

Part no. 067 832

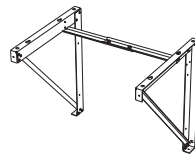

Sustainable energy solutions since 1952

NIBE has been manufacturing energy-efficient and sustainable climate solutions for your home for 70 years. It all began in Markaryd, in the southern Swedish province of Småland, and we recognise our Nordic heritage by utilising the power of nature. We combine renewable energy with smart technology to offer efficient solutions, allowing us to work together to create a more sustainable future.

Regardless of whether it is a chilly winter's day or a warm afternoon in the summer sun, we need a balanced indoor climate that allows us to enjoy a comfortable life, whatever the weather. Our extensive range of products supply your home with cooling, heating, ventilation and hot water, making it possible for you to create a pleasant indoor climate with little impact on the environment.

NIBE Energy Systems
Box 14, SE-285 21 Markaryd
nibe.eu



This product sheet is a publication from NIBE Energy Systems. All product illustrations, facts and data are based on current information at the time of the publication's approval. NIBE Energy Systems makes reservations for any factual or printing errors in this product sheet.