

Installer manual



Air/water heat pump

NIBE F2050 UK 1x230V



IHB EN 2318-2
631412

Table of Contents

1	Important information	4	F-series – VVM / SMO	35
	Safety information	4		
	Symbols	4		
	Marking	4		
	Serial number	4		
	Country specific information	5		
	Inspection of the installation	6		
	Compatible indoor modules and control modules	7		
	Indoor module	7		
	Control module	7		
2	Delivery and handling	8	8	Service
	Transport	8		36
	Assembly	8		Temperature sensor data
	Condensation	10		36
	Supplied components	11		
	Dismantling panels	12		
3	The heat pump design	14	9	Servicing and maintenance
	General	14		37
	Electrical connection	18		Important
	Sensor placement	20		37
				General inspection
				37
				Heating System
				37
4	Pipe connections	23	10	Disturbances in comfort
	General	23		38
	Symbol key	24		Troubleshooting
	Pipe coupling heating medium circuit	24		38
	Installation alternative	25		Alarm list
				39
5	Electrical connections	26	11	Accessories
	General	26		41
	Accessibility, electrical connection	26		
	Connections	27		
6	Commissioning and adjusting	32	12	Technical data
	Preparations	32		42
	Filling and venting	32		Dimensions
	Compressor heater	32		42
	Start-up and inspection	33		Sound levels
	Readjusting, heating medium side	33		43
	Adjustment, charge flow	33		Technical specifications
				44
				Energy labelling
				47
				Electrical circuit diagram
				50
7	Control - Heat pump EB101	34		Item register
	S-series – VVM S / SMO S	34		54
				Contact information
				59

Important information

Safety information

This manual describes installation and service procedures for implementation by specialists.

The manual must be left with the customer.

Symbols

Explanation of symbols that may be present in this manual.



NOTE

This symbol indicates danger to person or machine.



Caution

This symbol indicates important information about what you should consider when installing or servicing the installation.



TIP

This symbol indicates tips on how to facilitate using the product.

Marking

Explanation of symbols that may be present on the product's label(s).



Fire hazard!



Read the User Manual.



Read the User Manual.



Read the Installer Manual.

Serial number

The serial number for F2050 can be found on the side of the foot.

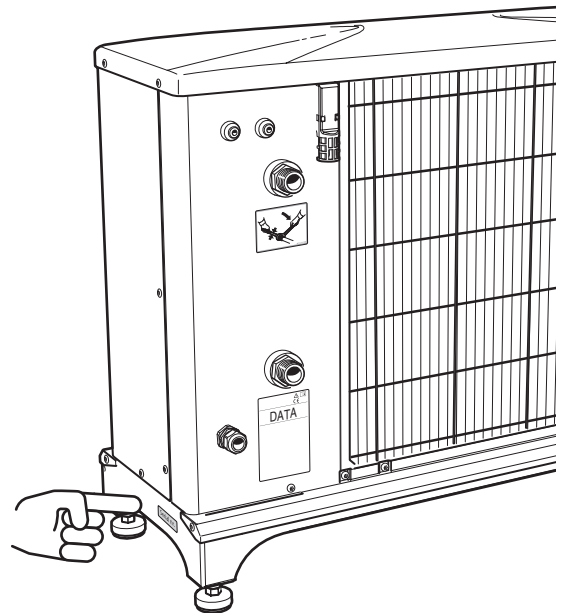

Caution

You need the product's (14 digit) serial number for servicing and support.

Country specific information

UNITED KINGDOM

This installation is subject to building regulation approval, notify the local Authority of intention to install.

Use only manufacturer's recommended replacement parts.

For more information see nibe.co.uk.



Benchmark places responsibilities on both manufacturers and installers. The purpose is to ensure that customers are provided with the correct equipment for their needs, that it is installed, commissioned and serviced in accordance with the manufacturers instructions by competent persons and that it meets the requirements of the appropriate Building Regulations. The Benchmark Checklist can be used to demonstrate compliance with Building Regulations and should be provided to the customer for future reference.

Installers are required to carry out the installation, commissioning and servicing work in accordance with the Benchmark Code of practice which is available from the Heating and Hotwater Industry Council who manage and promote the Scheme. Visit centralheating.co.uk for information.

Warranty and insurance information

Thank you for installing a new NIBE heat pump in your home.

NIBE heat pumps are manufactured in Sweden to the very highest standard so we are pleased to offer our customers a comprehensive guarantee.

The product is guaranteed for 24 months for parts and labour from the date of installation or 33 months from the date of manufacture, whichever is the shorter.

The NIBE guarantee is based on the unit being installed and commissioned by a NIBE accredited installer, serviced every year and the Benchmark documents completed. Where this condition is not met, any chargeable spare parts or components issued within the applicable guarantee period still benefit from a 12 month warranty from the date of issue by the manufacturer.

We recommend the installer completes and returns as soon as possible, your guarantee registration card or completes the guarantee form on the NIBE website, www.nibe.co.uk

Electrical Supply

The heat pump must be permanently connected to a 230 V ~ 50 Hz supply.

All system components shall be of an approved type and all wiring to current I.E.E wiring regulations.

External wiring must be correctly earthed, polarised and in accordance with the relevant standards: Currently this is BS 7671.

Heating System

The installation of the heat pump should follow best practice as covered in the following:

BS 5449 Forced circulation hot water central heating systems for domestic premises.

BS 15450 Heating systems in buildings – Design of heat pump heating systems.

Inspection of the installation

Current regulations require the heating installation to be inspected before it is commissioned. The inspection must be carried out by a suitably qualified person. Fill in the page for information about installation data in the User manual.

✓	Description	Notes	Signature	Date
	Heating medium (page 24)			
	System flushed			
	System vented			
	Particle filter			
	Shut-off and drain valve			
	Charge flow set			
	Electricity (page 26)			
	Fuses property			
	Safety breaker			
	Earth circuit-breaker			
	Heating cable type/effect			
	Fuse size, heating cable (F3)			
	Communication cable connected			
	F2050 addressed (only when cascade connection)			
	Connections			
	Main voltage			
	Phase voltage			
	When installing F2050-6, check that the software version of the indoor module/control module is at least v8320.			
	Miscellaneous			
	Warranty			
	Benchmark checklist			

Compatible indoor modules and control modules

	VVM S320	SMO S40
F2050-6	X	X
F2050-10	X	X

	VVM 225	SMO 20	SMO 40
F2050-6	X	X	X
F2050-10	X	X	X

Indoor module

VVM S320

Stainless steel, 1x230 V
With T&P valve
Part no. 069 199

VVM S330

Stainless steel, 1 x 230 V
Part no. 069 249

VVM S330

Stainless steel, 3 x 400 V
Part no. 069 250

VVM 225¹

Stainless steel, 1x230 V
With T&P valve
Part no. 069 232

Control module

SMO S40

Control module
Part no. 067 654

SMO 20

Control module
Part no. 067 224

SMO 40

Control module
Part no. 067 225

¹ In combination with S2125-12, the system must be supplemented with NIBE UKV. See "Flow equalisation" in the "Buffer vessel (UKV)" section in the Installer Manual for VVM 225.

Delivery and handling

Transport

F2050 should be transported and stored vertically in a dry place.

 **NOTE**
Ensure that the heat pump cannot fall over during transport.

Check that F2050 has not been damaged during transport.

LIFT FROM THE STREET TO THE SET UP LOCATION

If the surface allows, the easiest method is to use a pallet truck to move the heat pump to the installation area.

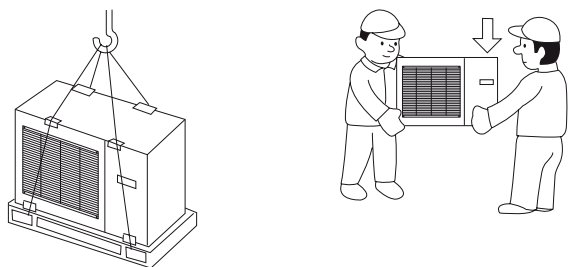

If the heat pump needs to be transported across soft ground, such as a lawn, we recommend using a crane truck that can lift it to the installation location. When the heat pump is lifted with a crane, the packaging must be intact.

If a crane truck cannot be used, the heat pump can be transported on an extended sack truck. The heat pump must be taken hold of from its heaviest side and two people are required to lift it.

LIFT FROM THE PALLET TO FINAL POSITIONING

Before lifting remove the packaging and the securing strap to the pallet.

Place lifting straps around each foot. It is recommended that two people perform the lift from the pallet to the base.

SCRAPPING

When scrapping, remove the heat pump in reverse order. In this case, lift by the base plate rather than the pallet!

Assembly

- Place the heat pump in a suitable location outdoors to prevent any risk of the refrigerant flowing in through ventilation openings, doors or similar openings in the event of a leak. It must also not constitute a hazard to people or property in any other way.
- If the heat pump is placed in a location where any refrigerant leak could accumulate, for example below ground level (in a dip or low-lying recess), the installation must satisfy

the same requirements that apply for gas detection and the ventilation of engineering rooms. Requirements regarding sources of ignition must be applied where appropriate.

- Place F2050 outdoors on a solid level base that can take the weight, preferably a concrete foundation. If concrete slabs are used they must rest on asphalt or shingle.
- The lower edge of the evaporator must not be lower than the level of the average local snow depth, or at least 300 mm above ground level. The base should be at least 70 mm tall.
- F2050 should not be positioned next to noise sensitive walls, for example, next to a bedroom.
- Also ensure that the placement does not inconvenience the neighbours.
- F2050 must not be placed so that recirculation of the outdoor air is possible. Recirculation entails reduced power and impaired efficiency.
- The evaporator must be sheltered from direct wind / , which negatively affects the defrosting function. Place F2050 protected from wind / against the evaporator.
- Large amounts of condensation, as well as melt water from defrosting, may be produced. Condensation must be led off to a drain or similar (see section "Condensation water").
- Care must be exercised so that the heat pump is not scratched during installation.

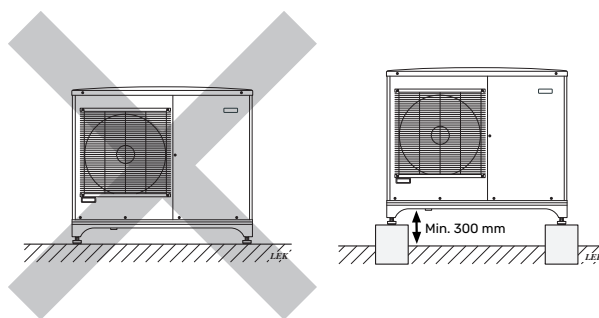

Do not place F2050 directly on the lawn or other non solid surface.

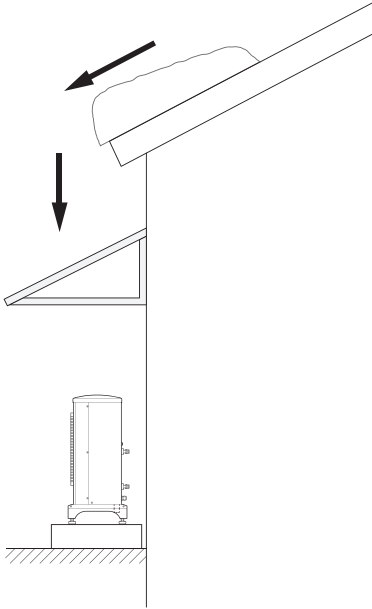

If there is a risk of snow slip from roof, a protective roof or cover must be erected to protect the heat pump, pipes and wiring.

INSTALLATION AREA

The distance between F2050 and the house wall must be at least 150 mm, but not more than 500 mm in locations that are exposed to the wind. The free space above F2050 must be at least 1,000 mm. The free space in front must be at least 1,000 mm for any future servicing.

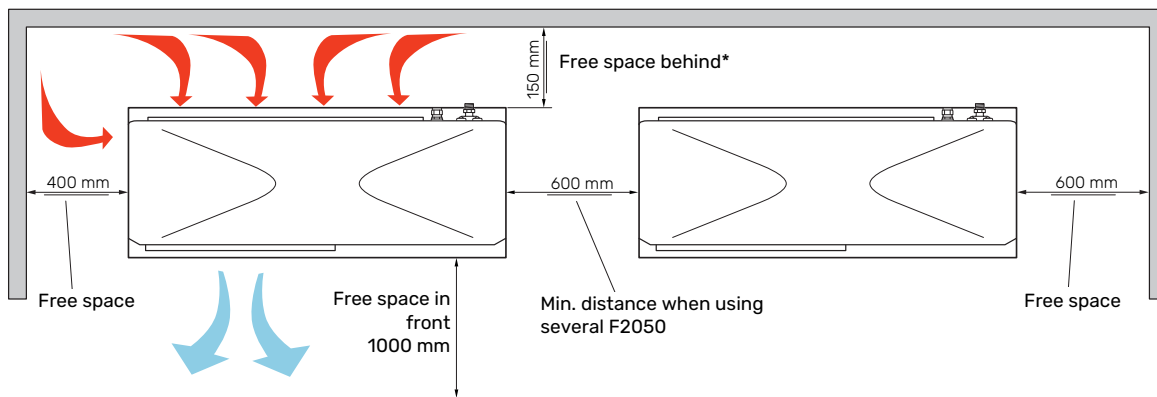

* The space behind must not exceed 500 mm in locations that are exposed to the wind.

Condensation

The condensate drain pan collects and leads away the condensation water.



NOTE

It is important to the heat pump function that condensation water is led away and that the drain for the condensation water run off is not positioned so that it can cause damage to the house. Condensation run-off should be checked regularly, especially during the autumn. Clean if necessary.

- The condensation water (up to 50 litres / 24 hrs) must be routed away by a pipe to an appropriate drain, it is recommended that the shortest outdoor length possible is used.
- The section of the pipe that can be affected by frost must be heated by the heating cable to prevent freezing.



TIP

Pipe with heating cable for draining the condensation water trough is not included.



TIP

To ensure this function, the accessory KVR should be used.

- Route the pipe downward from the heat pump.
- The outlet of the condensation water pipe must be at frost free depth.
- Use a water trap for installations where air circulation may occur in the condensation water pipe.
- The insulation must seal against the bottom of the condensation water trough.

DRAIN PAN HEATER, CONTROL

The drain pan heater is supplied with power when one of the following conditions is met:

1. The compressor has been in operation for at least 30 minutes after last start.
2. The ambient temperature is lower than 1 °C.

DRAINAGE OF CONDENSATION



Caution

If none of the following recommended alternatives is used, good drainage of condensation must be provided.

Stone caisson

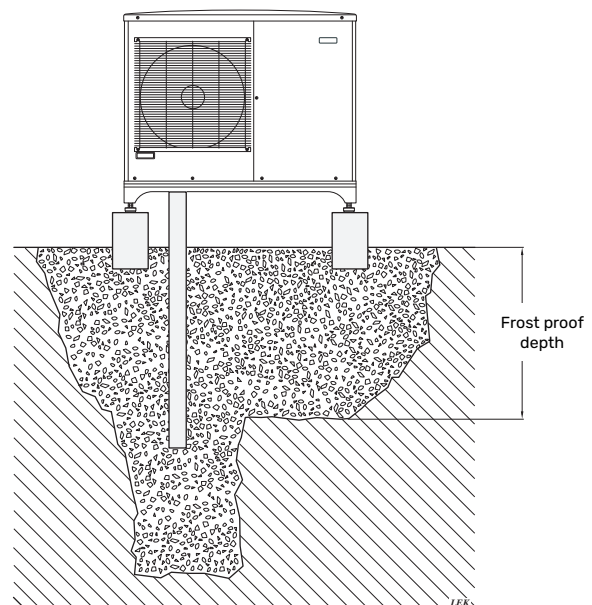

If the house has a cellar the stone caisson must be positioned so that condensation water does not affect the house. Otherwise the stone caisson can be positioned directly under the heat pump.

Gutter drainage

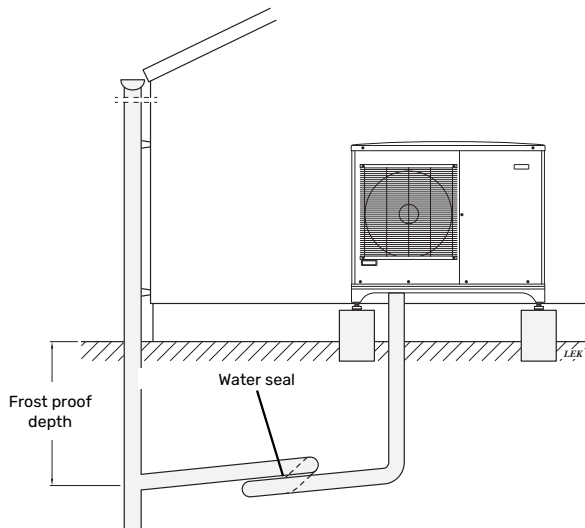

Route the pipe sloping downward from the heat pump. The condensation water pipe must have a water seal to prevent air circulation in the pipe.

Supplied components

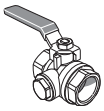

1 x filterball (G1") (QZ2)

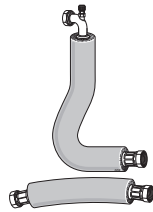

2 x flexible pipes (DN25, G1")
with 4 x gaskets

Dismantling panels

DISMANTLING TOP PANEL

F2050-6

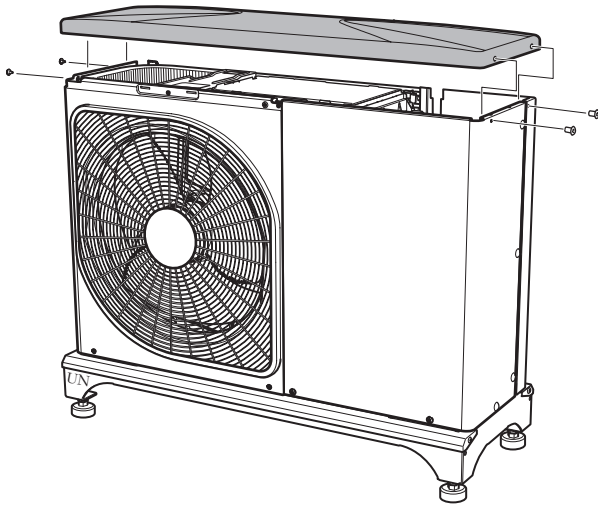

F2050-10

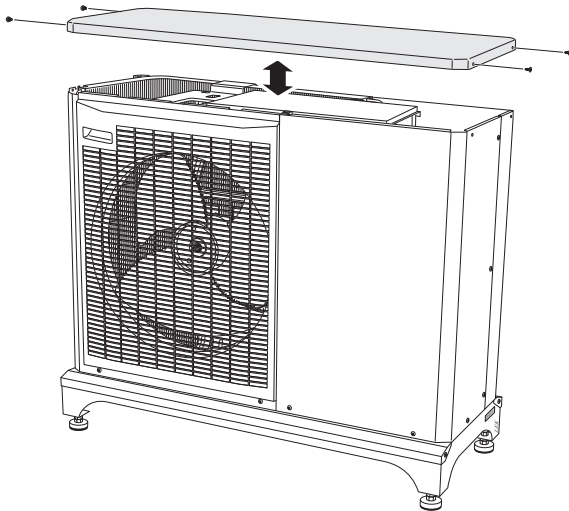

REMOVING THE FRONT PANEL

F2050-6

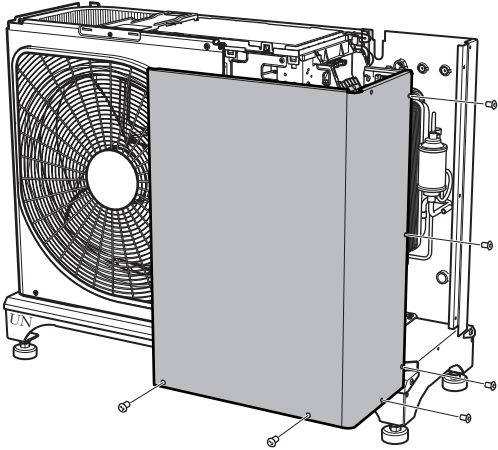

F2050-10

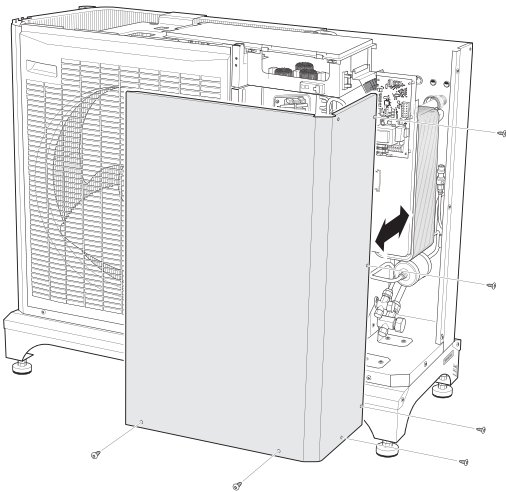

The heat pump design

General

F2050-6

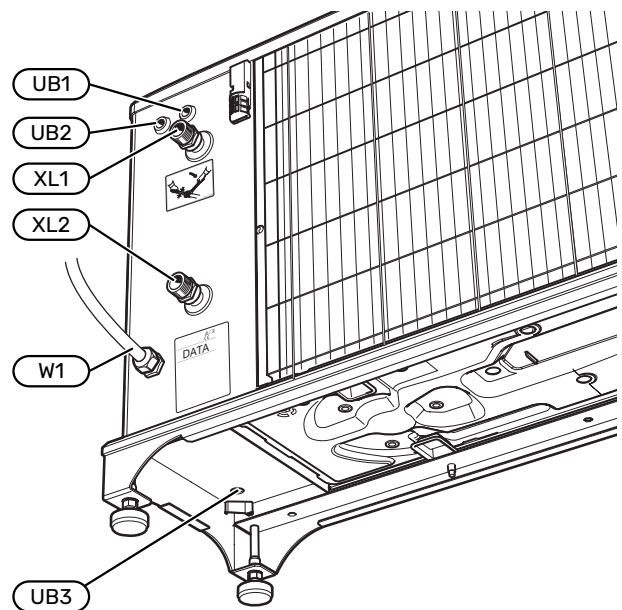
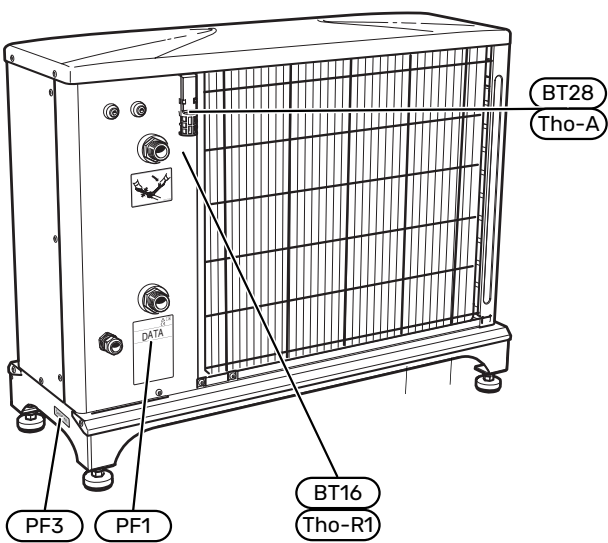
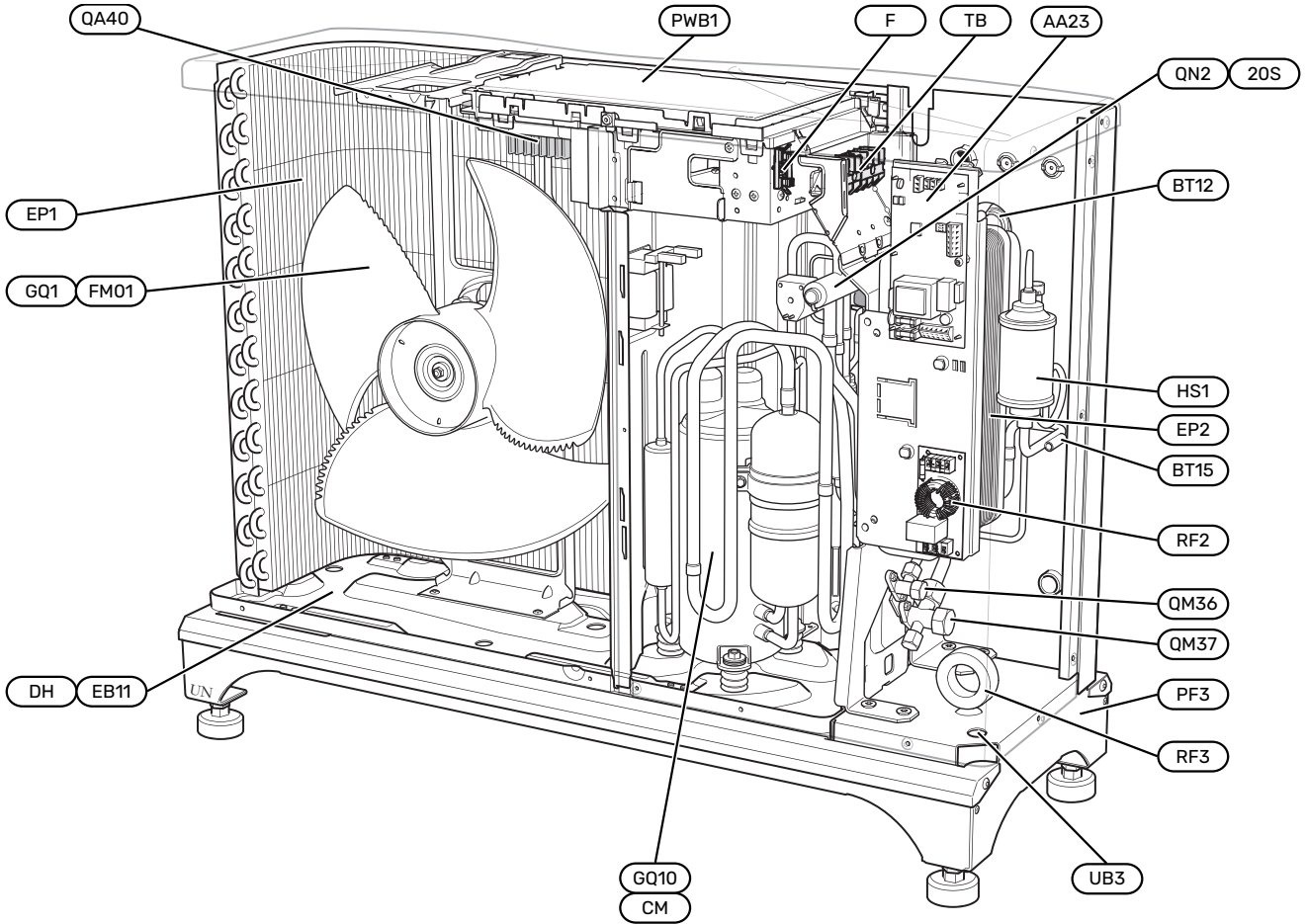

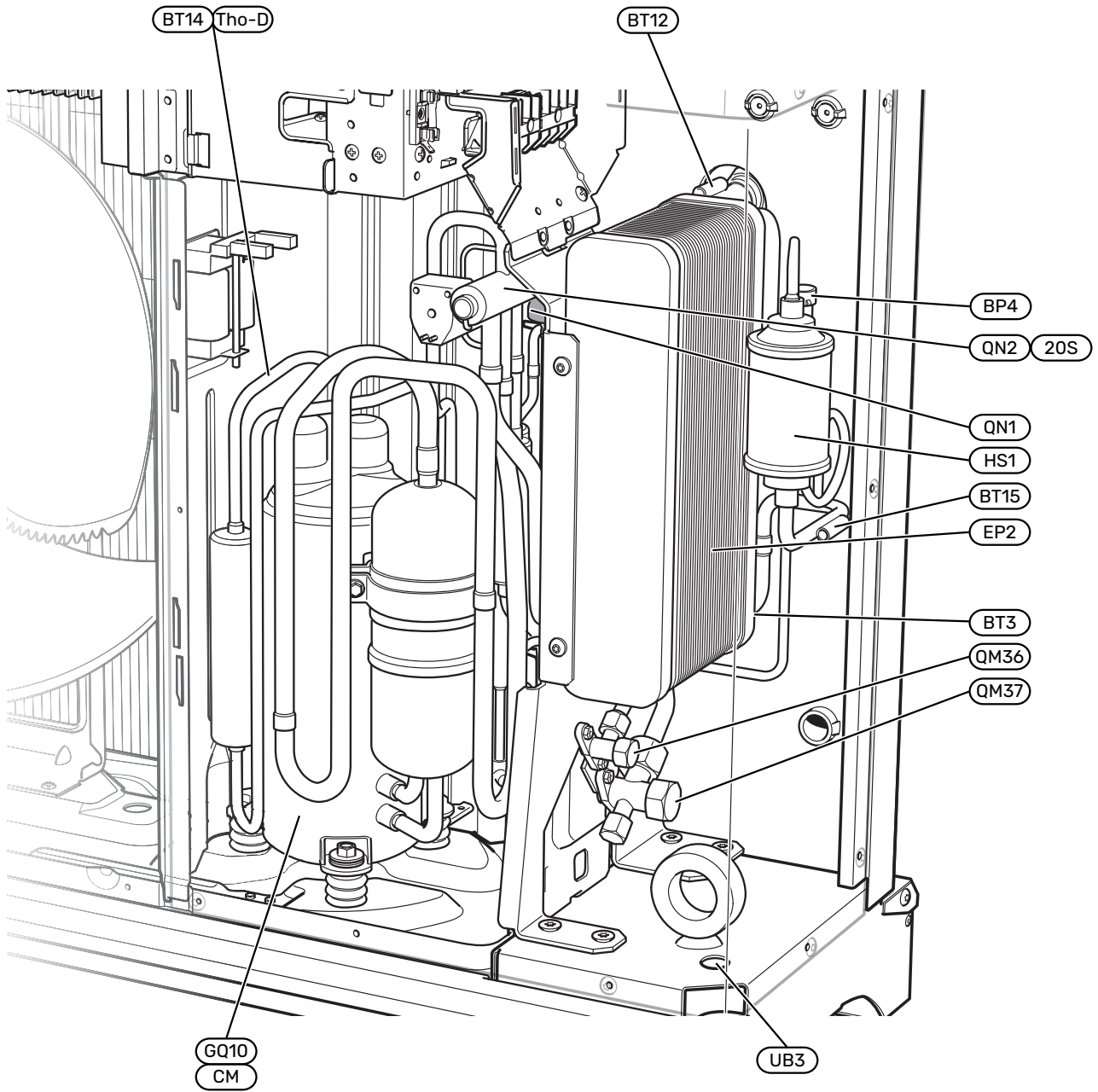

F2050-10

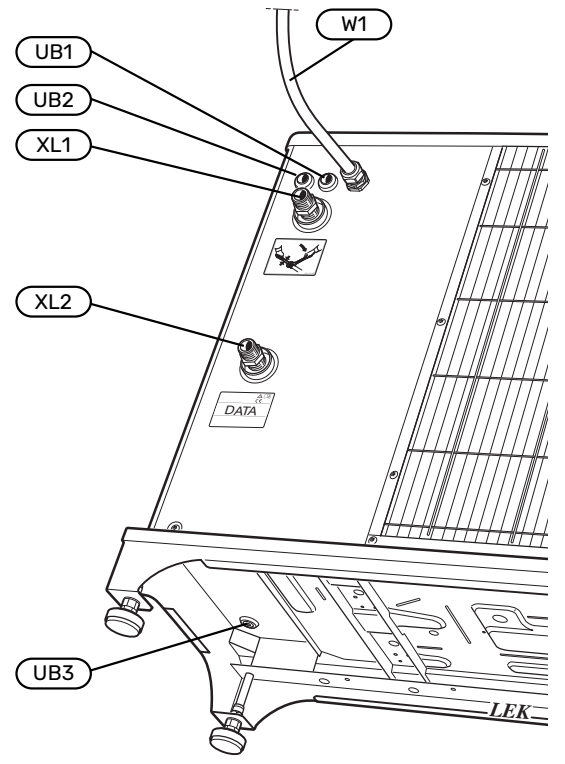
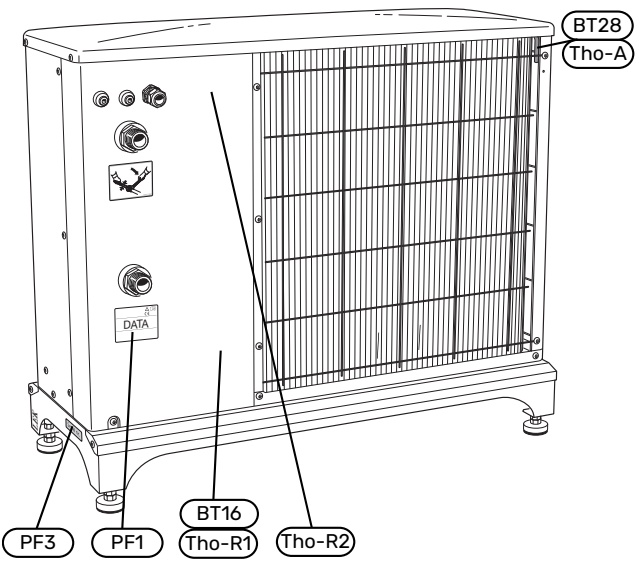
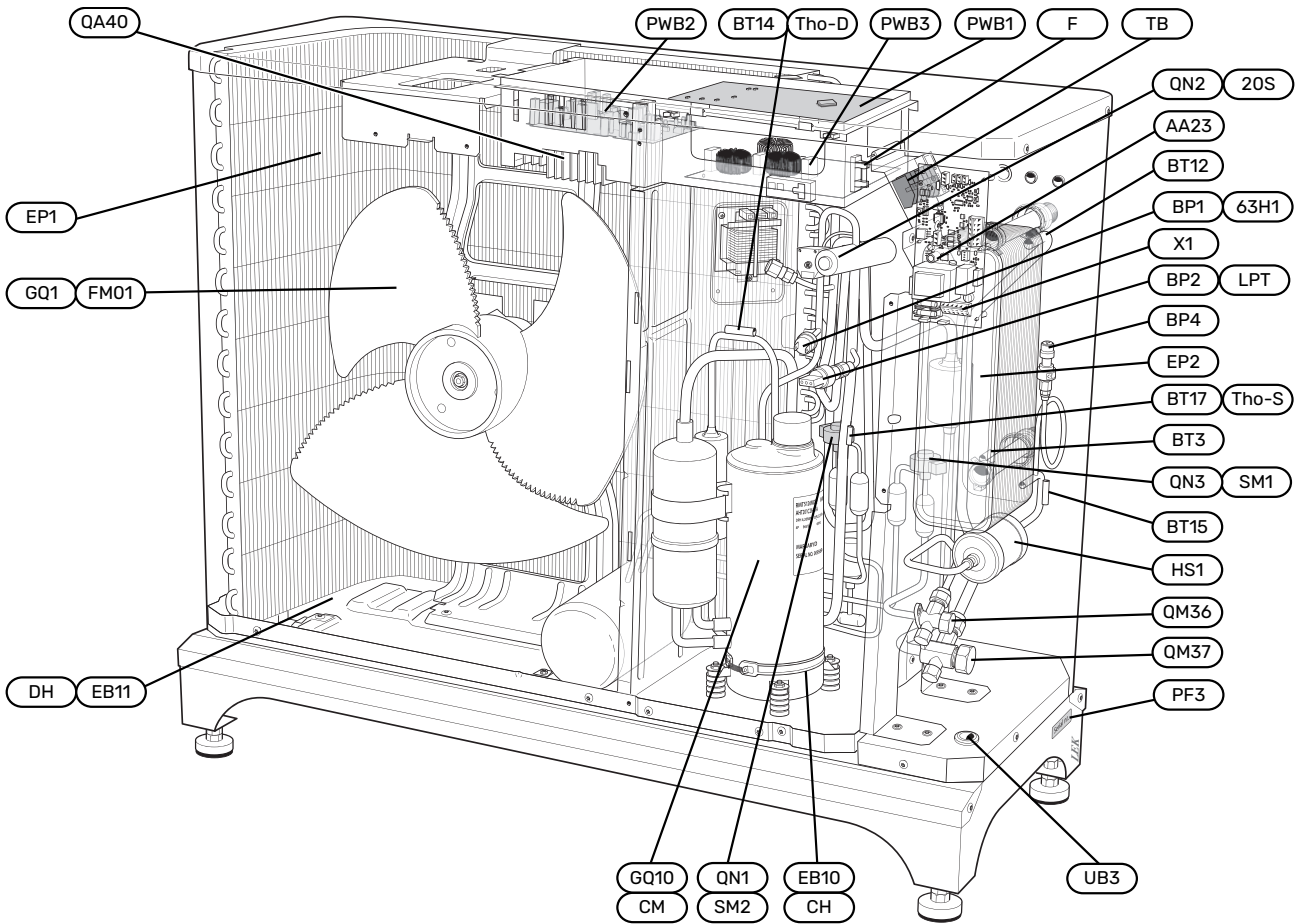

Pipe connections

XL1	Heating medium connection, supply (from F2050)
XL2	Heating medium connection, return (to F2050)

Sensors etc.

BF1	Flow meter
BP1 (63H1)	High pressure pressostat
BP2 (LPT)	Low pressure transmitter
BP8	Low pressure transmitter
BP9	High pressure sensor
BT3 (Tho-W1)	Temperature sensor, return
BT12 (Tho-W2)	Temperature sensor, condenser supply line
BT14 (Tho-D)	Temperature sensor, hot gas
BT15 (Tho-L)	Temperature sensor, fluid pipe
BT16 (Tho-R1)	Temperature sensor 1, evaporator
BT16 (Tho-R2)	Temperature sensor 2, evaporator
BT17 (Tho-S)	Temperature sensor, suction gas
BT28 (Tho-A)	Temperature sensor, ambient

Electrical components

AA23	Communication board
AA23-F3	Fuse for external heating cable
AA23-S3	DIP switch, addressing of outdoor module
AA23-X1	Terminal block, KVR
AA23-X4	Terminal block, communication from indoor module
AA23-X100	Terminal block, communication outdoor module
EB10 (CH)	Compressor heater
EB11 (DH)	Drip tray heater
F	Main fuse compressor unit
GQ1 (FM01)	Fan
(PWB1)	Control board
(PWB2)	Inverter board
(PWB3)	Filter board
QA40	Inverter
RF2	EMC filter for inverter
(TB)	Terminal block, incoming supply and communication with board AA23
X1	Terminal block, incoming supply

Cooling components

EP1	Evaporator
EP2	Condenser
GQ10 (CM)	Compressor
HS1	Drying filter
QM36	Shut-off valve, liquid line
QM37	Shut-off valve, gas line
QN1 (SM2)	Expansion valve, heating and cooling
QN2 (20S)	4-way valve
QN3 (SM1)	Expansion valve, cooling

Miscellaneous

PZ1	Type plate
PZ3	Serial number
UB1	Cable gland, incoming supply
UB2	Cable grommet, communication
UB3	Cable gland, heating cable (EB14)
UB4	Cable grommet, fan

Designations according to standard EN 81346-2.

Designations within brackets according to the supplier's standard.

Electrical connection

F2050-10

F2050-6

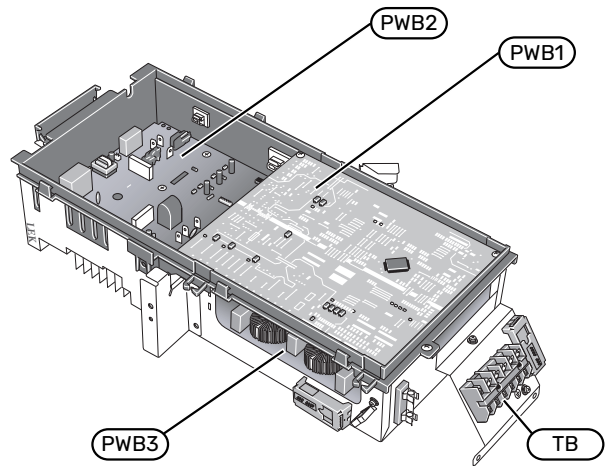
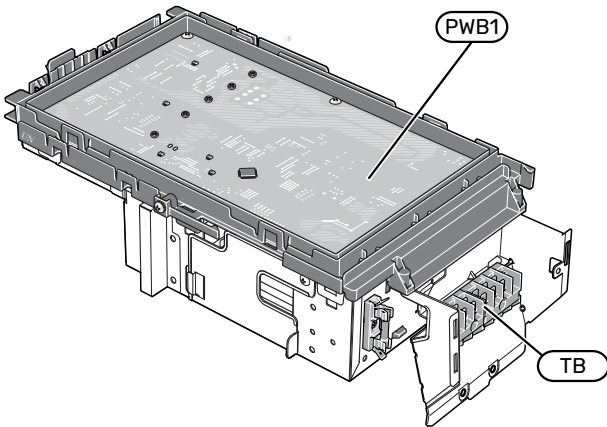
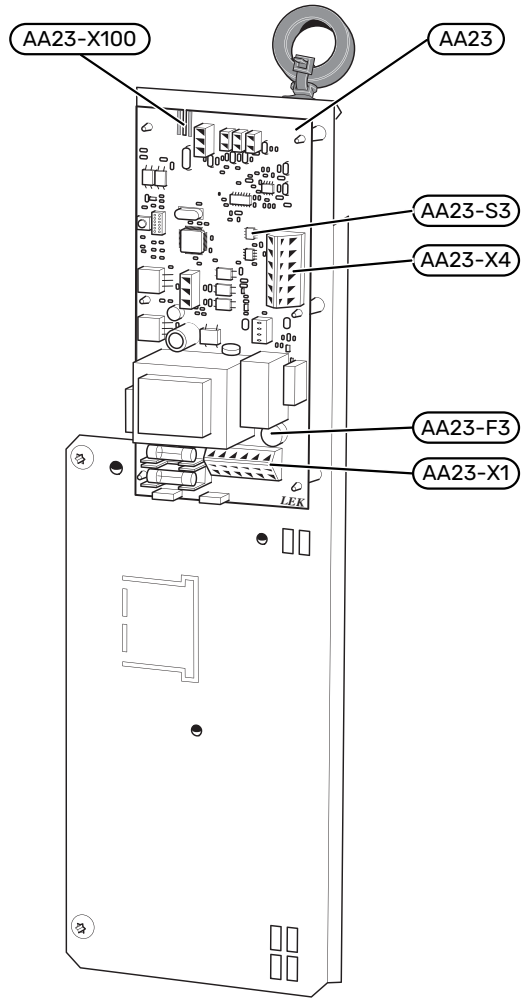
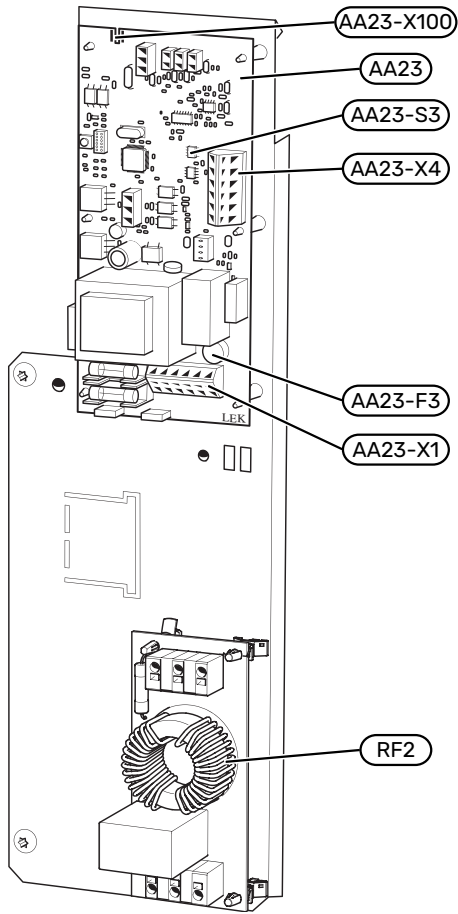

Electrical components

AA23	Communication board
AA23-F3	Fuse for external heating cable (250 mA), max 45 W.
AA23-S3	DIP switch, addressing of outdoor unit
AA23-X1	Terminal block, KVR
AA23-X4	Terminal block, communication from indoor module
AA23-X100	Communication with TB
EB10 (CH)	Compressor heater
EB11 (DH)	Drip tray heater
F	Main fuse compressor unit
GQ1 (FM01)	Fan
(PWB1)	Control board
(PWB2)	Inverter board
(PWB3)	Filter board
RF2	EMC-filter
(TB)	Terminal block, incoming supply and communication with board AA23
X1 (TB1)	Terminal block, incoming supply
X2 (TB2)	Terminal block, communications
X1	Terminal block, power supply

Designations according to standard EN 81346-2.

Designations within brackets according to the supplier's standard.

Sensor placement

CONNECTION TO BOARD (PWB1)

F2050-6

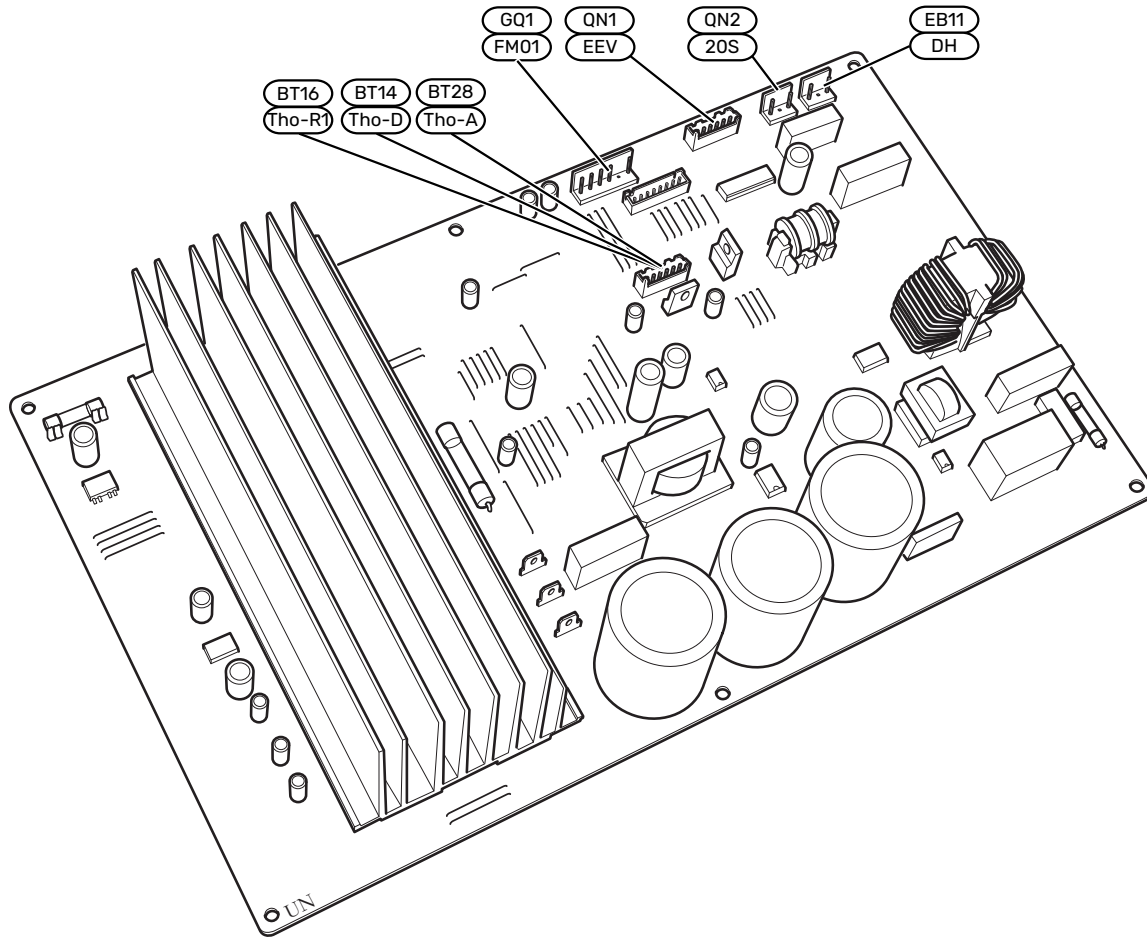

F2050-10

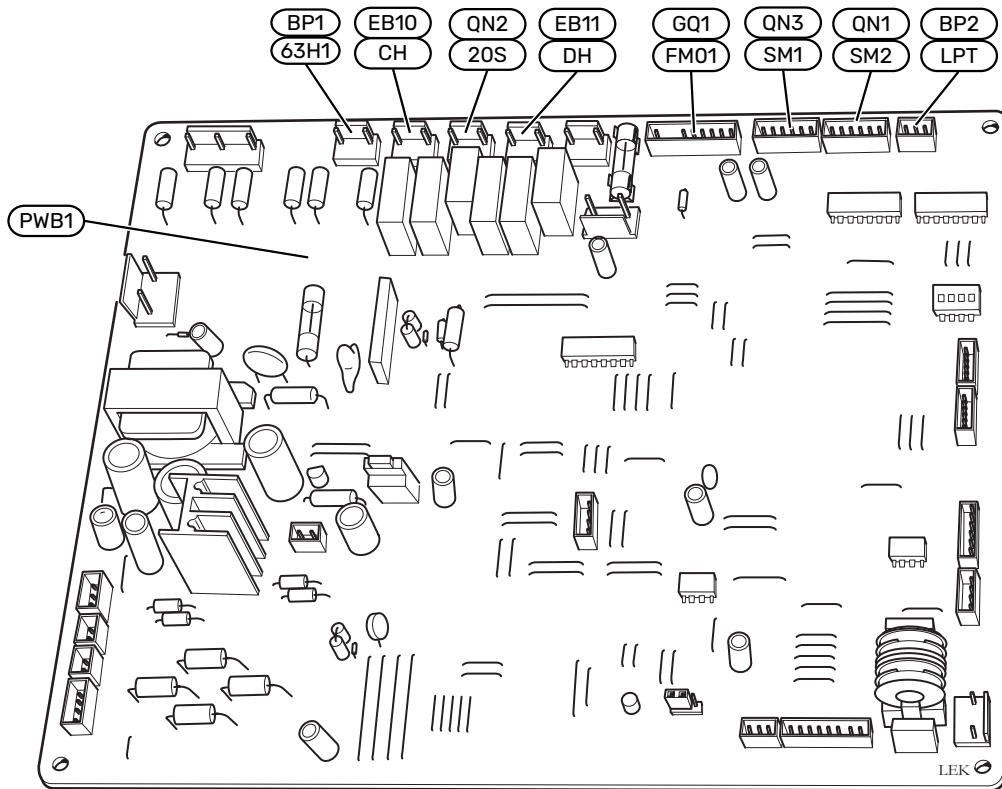

CONNECTION TO BOARD (AA23)

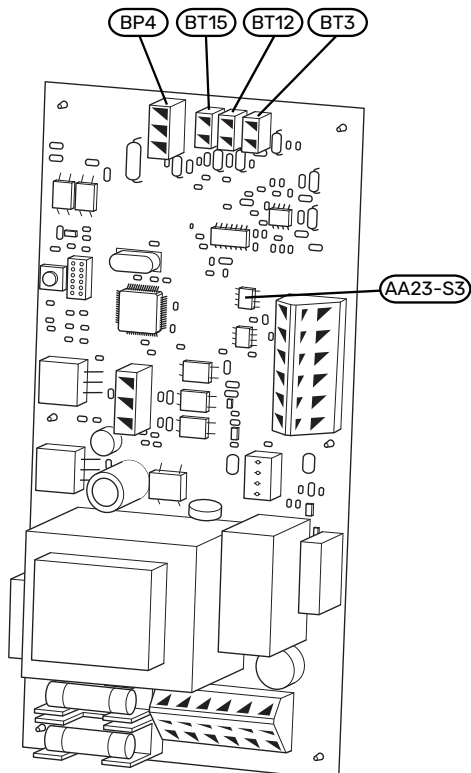

SENSOR PLACEMENT IN F2050

Outdoor module F2050-6

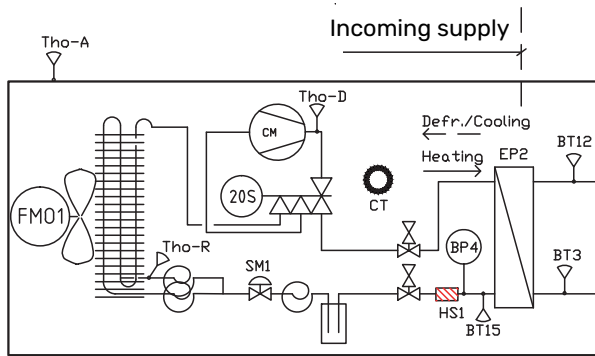

Outdoor module F2050-10

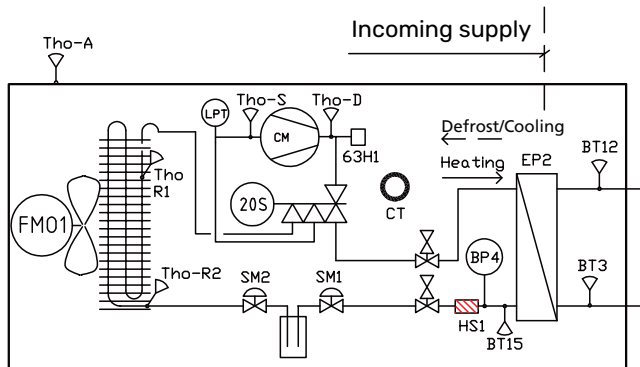

BE1 (CT)	Current sensor
BF1	Flow meter
BP1 (63H1)	High pressure pressostat
BP2 (LPT)	Low pressure transmitter
BT3 (Tho-W1)	Temperature sensor, heating medium return line
BT12 (Tho-W2)	Temperature sensor, condenser supply line
BT14 (Tho-D)	Temperature sensor, hot gas
BT15 (Tho-L)	Temperature sensor, fluid pipe
BT16 (Tho-R1)	Temperature sensor, heat exchanger, 1
BT16 (Tho-R2)	Temperature sensor, heat exchanger, 2
BT17 (Tho-S)	Temperature sensor, suction gas
BT28 (Tho-A)	Temperature sensor, ambient
EB10 (CH)	Compressor heater
EB11 (DH)	Drip tray heater
EP2	Condenser
GQ1 (FM01)	Fan
GQ10 (CM)	Compressor
HS1	Drying filter
QN1 (SM2)	Expansion valve, heating
QN2 (20S)	4-way valve
QN3 (SM1)	Expansion valve, cooling

Designations according to standard EN 81346-2.

Designations within brackets according to the supplier's standard.

Pipe connections

General

Pipe installation must be carried out in accordance with current norms and directives.

MINIMUM SYSTEM FLOWS

NOTE
An undersized climate system can result in damage to the product and lead to malfunctions.

Each climate system must be dimensioned individually to provide the recommended system flows.

The installation must be dimensioned to provide at least the minimum defrosting flow at 100 % circulation pump operation.

Air/water heat pump	Minimum flow during defrosting 100% circulation pump operation (l/s)	Minimum recommended pipe dimension (DN)	Minimum recommended pipe dimension (mm)
F2050-6	0.19	20	22
F2050-10			

F2050 can only operate up to a return temperature of about 55 °C and an outgoing temperature of about 58 °C from the heat pump.

F2050 is not equipped with shut-off valves on the heating medium side, rather these must be installed to facilitate any future servicing. The return temperature is limited by the return line sensor.

NOTE
This installation is subject to building regulation approval, notify the local Authority of intention to install.

NOTE
Use only manufacturer's recommended replacement parts.

HARD WATER AREAS

Normally, there should not normally be any problem installing F2050 in hard water areas, as the operating temperature is 50–60°C.

CLEANING THE CLIMATE SYSTEM

When the water heater and the climate system have been filled with water, F2050 must operate at maximum normal temperature for at least one hour. Thereafter the system must be drained of water and refilled.

Before installing the heat pump in an existing system, it is important that the system is properly flushed through.

Even if the heat pump is to be installed in a new system, the heat pump and system should be flushed.

NOTE
Ensure that cleaning agent has been removed from the entire system before adding inhibitor.

After flushing an inhibitor should be used for long-term anti-corrosion protection.

NIBE Energy Systems Limited recommends water treatments, supplied by Fernox, specifically designed for heat pumps.

WATER VOLUMES

When docking with F2050 free flow in the climate system is recommended for correct heat transfer. This can be achieved by use of a bypass valve. If free flow cannot be ensured, it is recommended that a buffer tank (NIBE UKV) is installed.

Following water volumes are recommended

F2050	-6	-10
Minimum volume, climate system during heating/cooling	20 l	50 l
Minimum volume, climate system during under floor cooling	50 l	80 l

NOTE
The pipe installation must be flushed out before the heat pump is connected so debris cannot damage component parts.





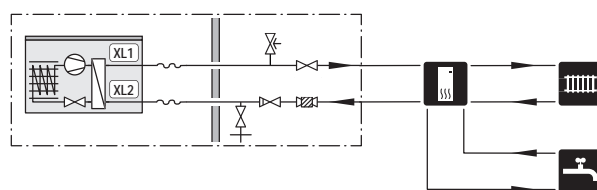









SYSTEM DIAGRAM

System principles with hot water and heating system.



- XL1 Heating medium connection, supply (from F2050)
- XL2 Heating medium connection, return (to F2050)

Symbol key

Symbol	Meaning
	Shut-off valve
	Tapping valve
	Non-return valve
	Circulation pump
	Expansion vessel
	Filterball
	Pressure gauge
	Safety valve
	Reversing valve/shunt
	Control module
	Domestic hot water
	Outdoor module
	Water heater
	Heating system

Pipe coupling heating medium circuit

You can find a list of compatible products in the section "Compatible indoor modules and control modules".



Caution

There is a difference between connection to a control module compared with connection to an indoor module.

See the Installer Manual for the indoor module/control module.

Vent the heat pump by the "heating medium supply" connection (XL1) using the venting nipple on the enclosed flexible hose.

Install as follows:

- expansion vessel
- pressure gauge
- safety valves
- drain valve

For draining the heat pump during prolonged power failures.

- non-return valve

Installations with only one heat pump: a non-return valve is only required in those cases where the placement of the products in relation to each other can cause self-circulation.

Cascade installations: each heat pump must be fitted with a non-return valve.

- charge pump
- shut-off valve

To facilitate any future servicing.

- enclosed filterball (QZ2)

Installed before connection "heating medium return" (XL2) (the lower connection) on the vacuum pump.

- reversing valve.

When connecting to the control module, and if the system is to be able to work with both the climate system and the hot water heater.

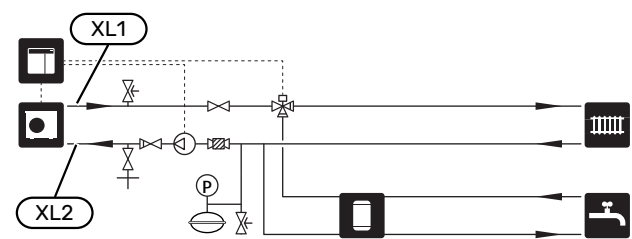

The image shows connection to the control module.

Before installing the heat pump in an existing system, it is important that the system is properly flushed through.

Even if the heat pump is to be installed in a new system, the heat pump and system should be flushed.



NOTE

Ensure that cleaning agent has been removed from the entire system before adding inhibitor.

After flushing an inhibitor should be used for long-term anti-corrosion protection.

NIBE Energy Systems Limited recommends water treatments (supplied by e.g. Fernox and Sentinel) specifically designed for heat pumps.

CHARGE PUMP

The charge pump (not included in the product) is powered and controlled from the indoor module/control module. It has a built-in frost protection function and, for this reason, must not be switched off when there is a risk of freezing.

At temperatures below +2 °C the charge pump runs periodically, to prevent the water from freezing in the charge circuit. The function also protects against excess temperatures in the charge circuit.

PRESSURE DROP, HEATING MEDIUM SIDE

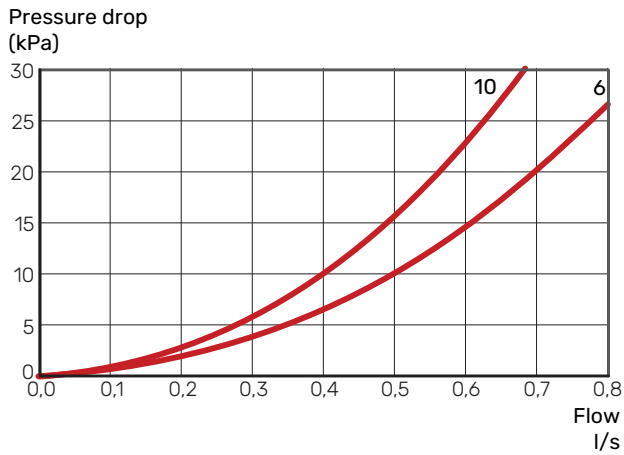

PIPE CONNECTIONS FLEX HOSE

All outdoor pipes must be insulated with at least 19 mm thick pipe insulation.

The supplied flexible hoses act as vibration dampers. The flexible pipes are fitted so an elbow is created, thus acting as vibration damping.

Installation alternative

F2050 can be installed with indoor module or control module. The necessary safety equipment must be installed in accordance with current regulations for all docking options.

The necessary safety equipment must be installed in accordance with current regulations for all of the installation options.

See nibe.eu for more installation options.

CONNECTING ACCESSORIES

Instructions for connecting accessories can be found in the installation instructions provided for each accessory. See section Accessories for a list of the accessories that can be used with F2050.

Electrical connections

General

- Electrical installation and wiring must be carried out in accordance with national provisions.
- Prior to insulation testing the house wiring, disconnect the air/water heat pump installation.
- If a miniature circuit breaker is used, this must have at least triggering characteristic "C". See section "Technical specifications" for fuse size.
- If the building is equipped with an RCD, F2050 must be equipped with a separate one.
- F2050 must be installed via an isolator switch. The cable area has to be dimensioned based on the fuse rating used.
- The RCD should have a nominal tripping current of no more than 30 mA. The incoming supply must be 230V~50Hz via an electrical distribution unit with fuses.
- The routing of cables for heavy current and signals should be made out through the cable glands on the heat pump's right-hand side, seen from the front.
- The communication cable must be a screened cable with three conductors.
- Connect the charge pump to the control module. See where the charge pump is to be connected in the Installer Manual for your control module.



NOTE

Do not start the system before filling up with water. Components in the system could be damaged.



NOTE

To prevent interference, sensor cables to external connections must not be laid close to high voltage cables.

Accessibility, electrical connection

See section "Dismantling panels".



NOTE

Electrical installation and any servicing must be carried out under the supervision of a qualified electrician. Disconnect the current using the circuit breaker before carrying out any servicing.



NOTE

Check the connections, main voltage and phase voltage before the product is started, to prevent damage to the heat pump electronics.



NOTE

The live external control must be taken into consideration when connecting.



NOTE

If the supply cable is damaged, only NIBE, its service representative or similar authorised person may replace it to prevent any danger and damage.

Connections

POWER CONNECTION

Incoming supply cable (W1) is enclosed and connected to terminal block X1 at the factory. Outside the heat pump there is approx. 1.8 m of cable available.

List of components

- UB1 Cable grommet, cascade connection
- UB2 Cable grommet, communication
- UB3 Cable gland, heating cable (EB14)
- XL1 Heating medium connection, supply (from F2050)
- XL2 Heating medium connection, return (to F2050)

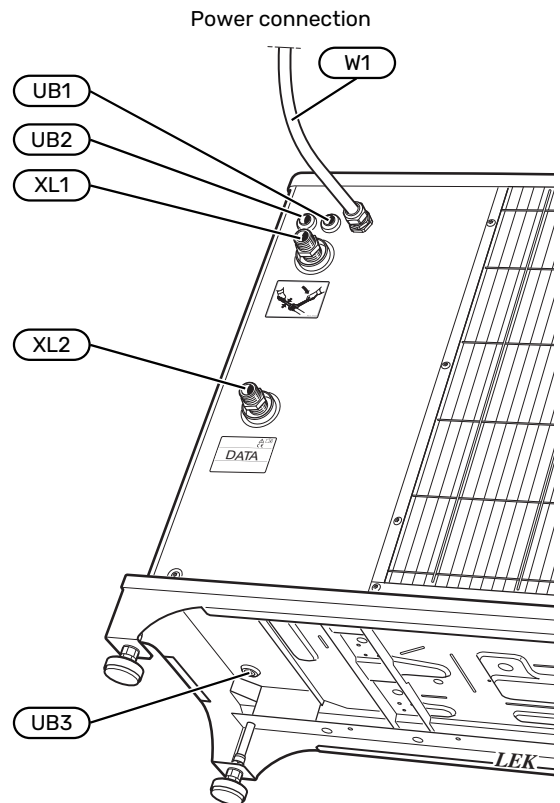
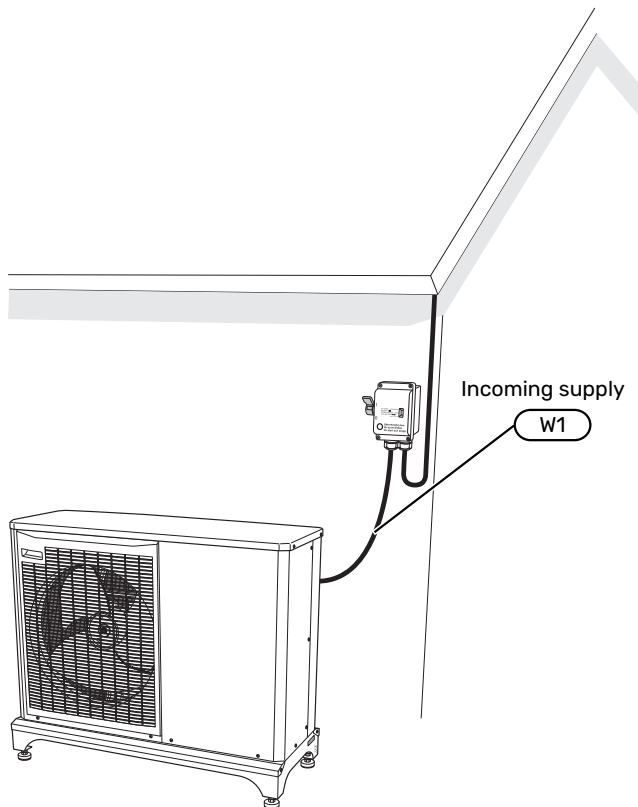

Communication cable (provided by installer) must be routed through cable grommet, communication (UB2), connected to terminal block AA23-X4 and secured with two cable ties.

For connection of accessory KVR, heating cable (EB14) is connected via cable gland UB3, see section "External heating cable KVR (Accessory)".

F2050-6

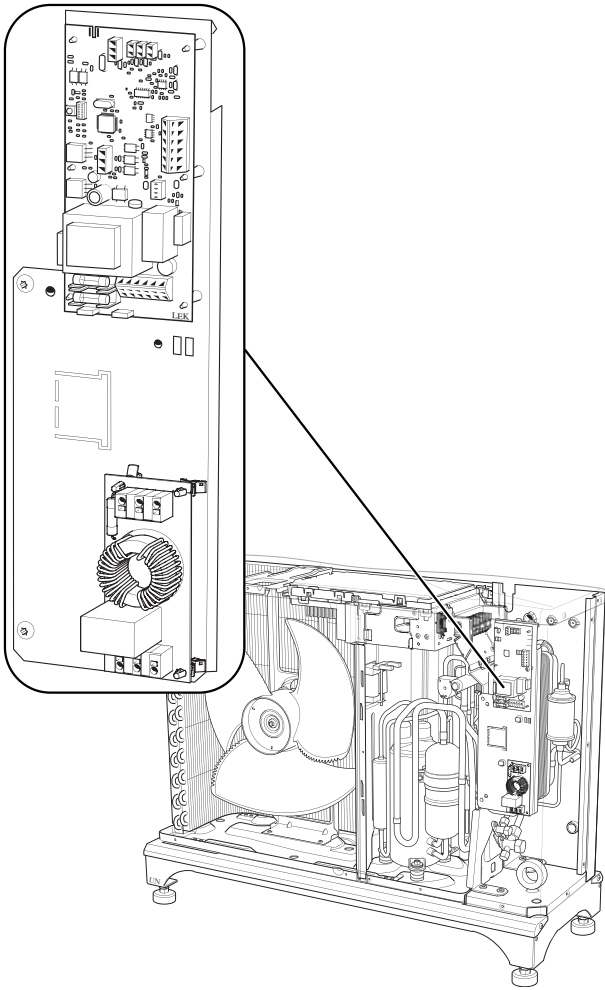

F2050-10

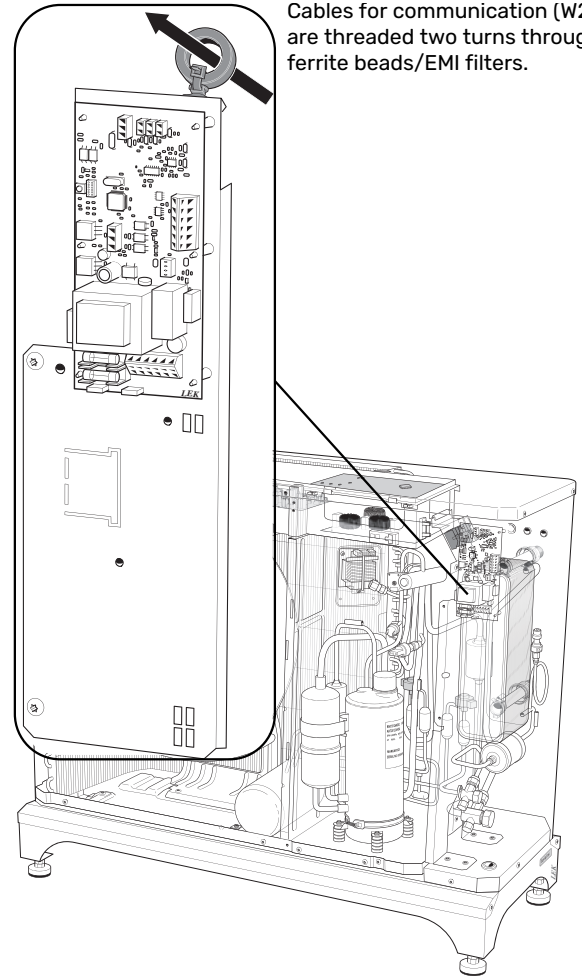

Cables for communication (W2) are threaded two turns through ferrite beads/EMI filters.

EXTERNAL HEATING CABLE KVR (ACCESSORY)

F2050-6 / -10

F2050 is equipped with a terminal block for external heating cable (EB14, not enclosed). The connection is fused with 250 mA (F3 on the communication board AA23). If another cable is to be used, the fuse must be replaced with a suitable one (see table).



NOTE

Self regulating heating cables must not be connected.

Length, heating cable (m)	P _{tot} (W)	Fuse (F3)	Part No.
1	15	T100mA/250V	718 085
3	45	T250mA/250V	518 900 ¹
6	90	T500mA/250V	718 086

¹ Fitted at the factory.

Connect external heating cable (EB14) to terminal block X1:4-6 as illustrated below:

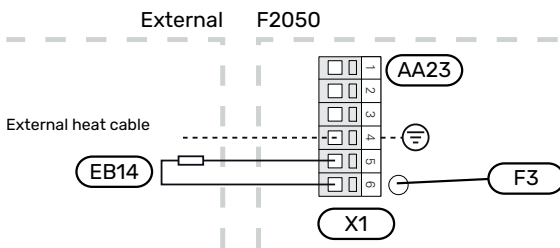

NOTE

The pipe must be able to withstand the heat from the heating cable.

To ensure this function, the accessory KVR should be used.

Cable routing

The following images show recommended cable routing from the electrical connection to the condensation pipe. Route the heating cable (EB14) through the gland on the underside and secure with two cable ties at the electrical connection. The transition between the electrical cable and the heating cable must occur after the gland to the condensation pipe.

F2050-6

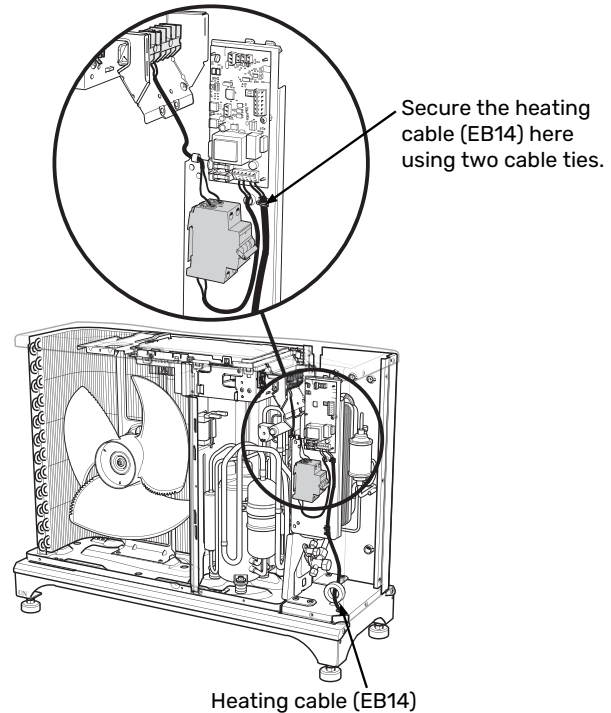

F2050-10

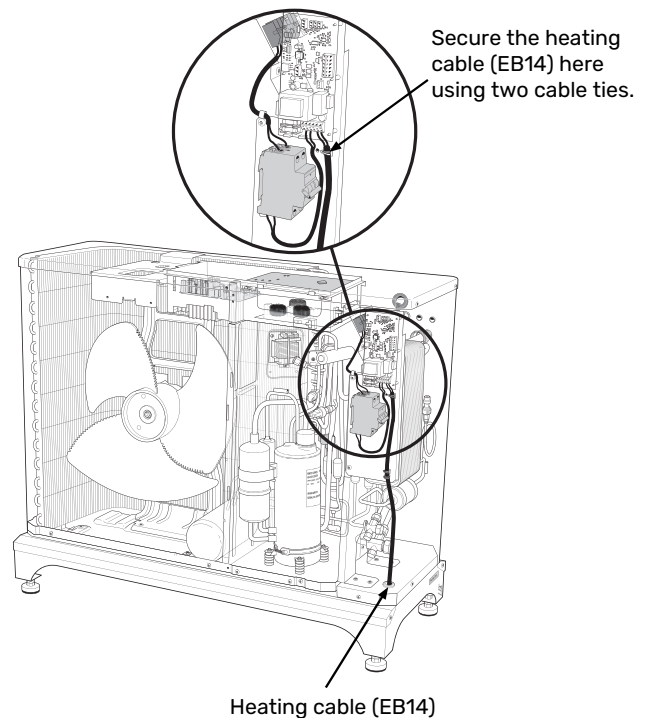

AMBIENT TEMPERATURE SENSOR

An ambient temperature sensor BT28 (Tho-A) is located on the rear of F2050.

COMMUNICATION

For connection of indoor module / control module, see relevant manual on nibe.co.uk.

Software version

To allow F2050 to communicate with indoor module/control module, you may need to update to a more recent software version.

Connection to indoor module

Communication cable (W2) is inserted from the rear through "cable grommet, communication" (UB2).

F2050 can communicate with indoor modules, by connecting the indoor module to the terminal block AA23-X4:1-3.

VVM S

Indoor module

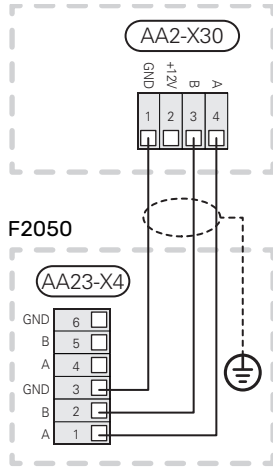

Connection to control module

SMO 20

F2050 can communicate with control module (SMO 20), by connecting the terminal block for communication (AA23-X4:1, 2, 3) in F2050 to the terminal block for communication in SMO 20, X2-19(A), -20(B), -21(GND).

Stripped length of conductor is 6 mm.

F2050

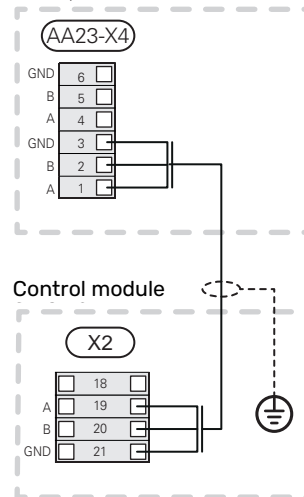

VVM

Indoor module

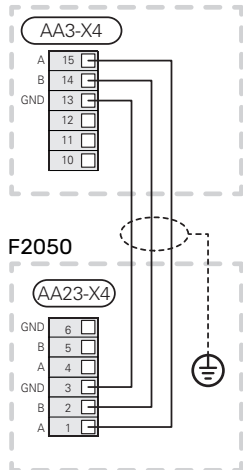

Cascade connection

SMO S40

F2050 (one or more) can communicate with control module (SMO S40), by connecting the terminal block for communication (AA23-X4:1, 2, 3) in F2050 to the terminal block for communication in SMO S40, AA100:X9-4(A), -5(B), -6(GND).

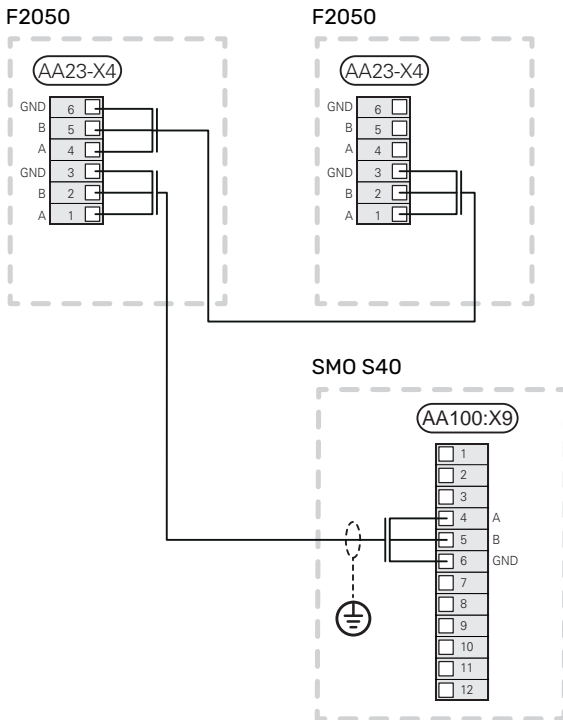

Addressing via cascade connection

On the communication board (AA23-S3), the communication address is selected for F2050 to the control module. The default address for F2050 is **1**. In a cascade connection, all F2050 must have a unique address. The address is coded in binary.

Address	S3:1	S3:2	S3:3
1	OFF	OFF	OFF
2	On	OFF	OFF
3	OFF	On	OFF
4	On	On	OFF
5	OFF	OFF	On
6	On	OFF	On
7	OFF	On	On
8	On	On	On

SMO 40

F2050 (one or more) can communicate with control module (SMO 40), by connecting the terminal block for communication (AA23-X4:1, 2, 3) in F2050 to the terminal block for communication in SMO 40, AA5:X4-1(A), -2(B), -3(GND).

Stripped length of conductor is 6 mm.

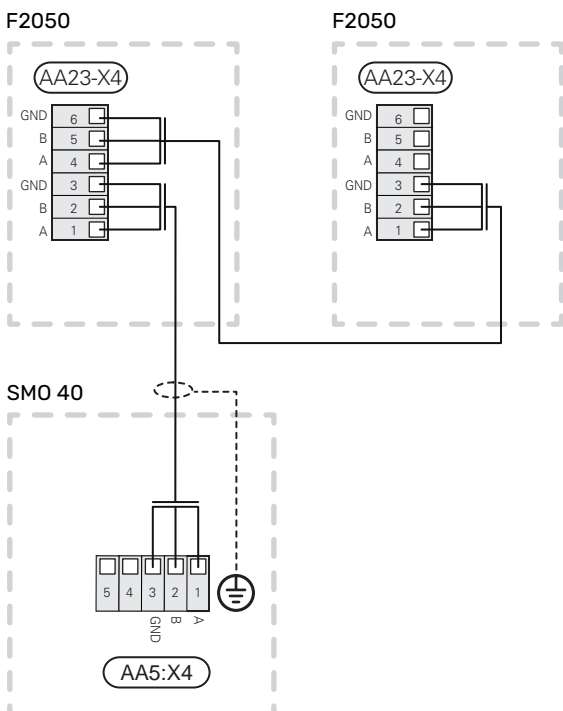

Commissioning and adjusting

Preparations

- Before commissioning, check that the charge circuit and climate system are filled and well vented.
- Check the pipe system for leaks.



NOTE

At the time of commissioning, complete all relevant sections of the Benchmark Checklist located at the back of this document.

Completion of the Benchmark Checklist is a condition of warranty. For full terms and conditions of warranty, please see our website nibe.co.uk.

Filling and venting

Filling and venting the heating medium system.

1. The heating medium system is filled with water to the required pressure.
2. Vent the system using the venting nipple (QM20) on the enclosed flexible hose and possibly the circulation pump.

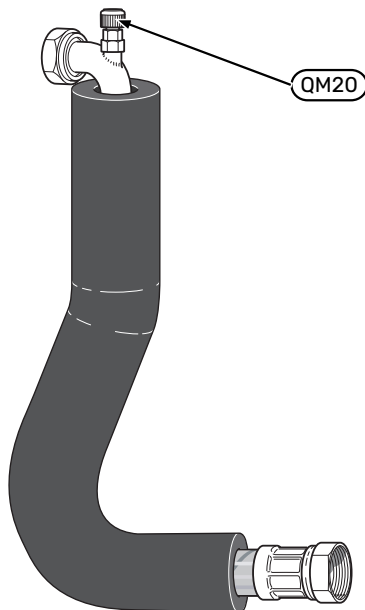

Compressor heater

F2050 (does not apply to F2050-6) is equipped with a compressor heater that heats the compressor before start-up and when the compressor is cold.



NOTE

The compressor heater must have been connected for 6 – 8 hours before the first start, see the section “Start-up and inspection” in the Installer Manual for the indoor section

Start-up and inspection

1. The compressor heater (CH) must have been operational for at least 6 - 8 hours before the compressor start can be initiated. This is done by switching on the control voltage and disconnecting the communication cable.
2. F2050 must be addressed, if it is to have an address other than 1. See chapter "Addressing via cascade connection".
3. The communication cable on the terminal block AA23-X4 must not be connected.
4. Turn the isolator switch on.
5. Ensure that the F2050 is connected to the power source.
6. After 6 - 8 hours, connect the communication cable (W2) to the terminal block AA23-X4.
7. Restart the indoor module. Follow the instructions for "Start-up and inspection" in the installation manual for the indoor module.

The heat pump starts 30 minutes after the outdoor unit has been powered up and the communication cable (W2) has been connected, if necessary.

If scheduled *silent operation* is required, it must be scheduled in the inner section or control unit.



NOTE

Do not start any electrical work until at least two minutes after cutting the power.



Caution

Silent mode should only be scheduled periodically because the maximum output is limited to approx. the nominal values.

F2050-6 / -10

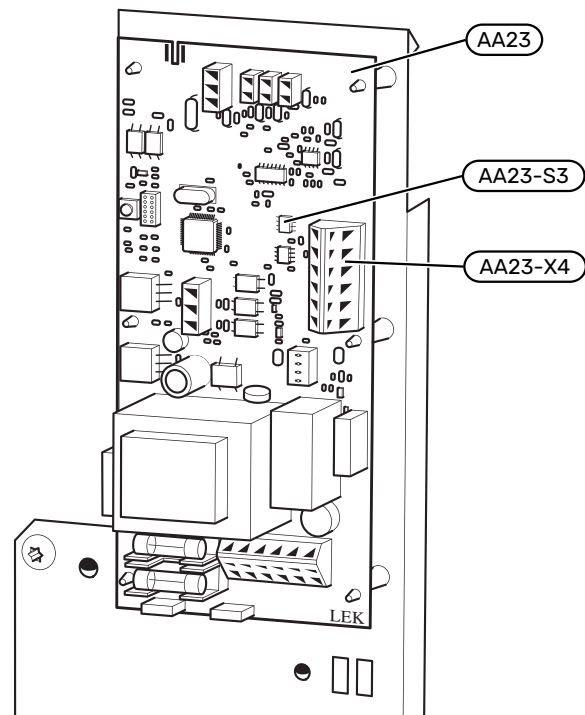

Readjusting, heating medium side

Air is initially released from the hot water and venting may be necessary. If bubbling sounds can be heard from the heat pump, the circulation pump and radiators the entire system will require further venting. When the system is stable (correct pressure and all air eliminated) the automatic heating control system can be set as required.

Adjustment, charge flow

Instructions for adjusting hot water charging are in the Installer Manual for the relevant indoor module. See section Accessories for a list of the indoor units and accessories that can be connected to F2050.

Control - Heat pump EB101

S-series – VVM S / SMO S

These settings are made on the display on the indoor module/control module.

MENU 7.3.2 - INSTALLED HEAT PUMP

Here, you make specific settings for the installed heat pump.

Cooling permitted

Alternative: on/off

Silent mode permitted

Alternative: on/off

Max. frequency 1

Setting range: 25 – 120 Hz

Max. frequency 2

Setting range: 25 – 120 Hz

Compressor phase

Setting range F2050 1 x 230 V: L1, L2, L3

Detect compressor phase

Alternative F2050 1 x 230 V: on/off

Current limit

Alternative F2050 1 x 230 V: on/off

Max. current

Setting range F2050 1 x 230 V: 6 – 32 A

Stop temperature compressor

Setting range -20 – -2 °C

blockFreq 1

Alternative: on/off

From frequency

Setting range: 25 – 117 Hz

To frequency

Setting range: 28 – 120 Hz

blockFreq 2

Alternative: on/off

From frequency

Setting range, cooling,

F2050-6: 20 – 106 Hz

Setting range, cooling,

F2050-10: 12 – 90 Hz

To frequency

Setting range, heating,

F2050-6: 20 – 110 Hz

Setting range, heating,

F2050-10: 20 – 120 Hz

Silent mode permitted: Here, you set whether silent mode will be activated for the heat pump. Note, it is now possible to schedule when silent mode will be active. The function should only be used for limited periods, because F2050 might not reach its dimensioned power.

Detect compressor phase: This shows in which phase the heat pump detected that you have F2050 230V~50Hz. Phase detection normally occurs automatically in connection with start-up of the indoor module/control module. This setting can be changed manually.

Current limitation: Here, you set whether the current limitation function will be activated for the heat pump, if you have F2050 230V~50Hz. During active function, you can limit the value of the maximum current.

BlockFreq 1: Here, you can select a frequency range within which the heat pump is not permitted to work. This function can be used if certain compressor speeds cause disturbing noise in the house.

BlockFreq 2: Here, you can select a frequency range within which the heat pump is not permitted to work.

Cooling permitted: Here, you can set whether the cooling function will be activated for the heat pump.

F-series – VVM / SMO

These settings are made on the display on the indoor module/control module.

MENU 5.11.1.1 - HEAT PUMP

Here, you make specific settings for the installed heat pump.

Cooling permitted

Setting range: off / on

Silent mode permitted

Setting range: yes / no

Detect compressor phase

Setting range F2050 1 x 230 V: off/on

Current limit

Setting range: 6 – 32 A

Factory setting: 32 A

blockFreq 1

Setting range: yes / no

blockFreq 2

Setting range: yes / no

Cooling permitted: Here, you can set whether the cooling function will be activated for the heat pump.

Silent mode permitted: Here, you set whether silent mode will be activated for the heat pump. Please note that you now have the option to schedule when silent mode will be active.

The function should only be used for limited periods, because F2050 possibly may not reach its dimensioned output.

Detect compressor phase: This shows in which phase the heat pump detected that you have F2050 230V-50Hz. Phase detection normally occurs automatically in connection with start-up of the indoor module/control module. This setting can be changed manually.

Current limitation: Here, you set whether the current limitation function will be activated for the heat pump, if you have F2050 230V-50Hz. During active function, you can limit the value of the maximum current.

BlockFreq 1: Here, you can select a frequency range within which the heat pump is not permitted to work. This function can be used if certain compressor speeds cause disturbing noise in the house.

BlockFreq 2: Here, you can select a frequency range within which the heat pump is not permitted to work.

Service

Temperature sensor data

DATA FOR TEMPERATURE SENSOR IN F2050-6

Tho-D

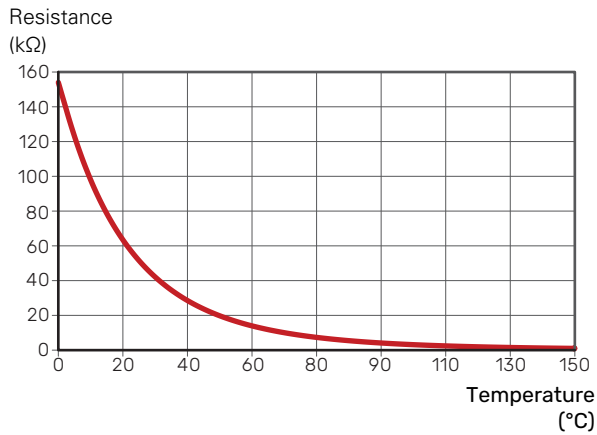

Tho-A, R

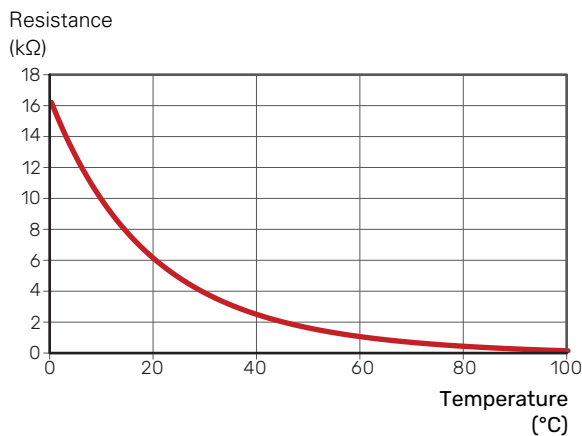

DATA FOR TEMPERATURE SENSOR IN F2050-10

Tho-D

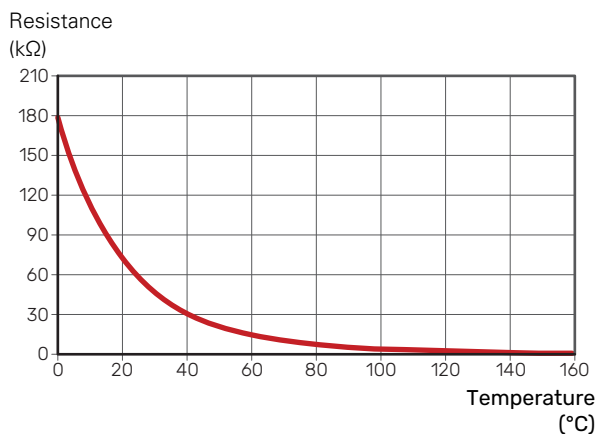

Tho-S, Tho-R1, Tho-R2

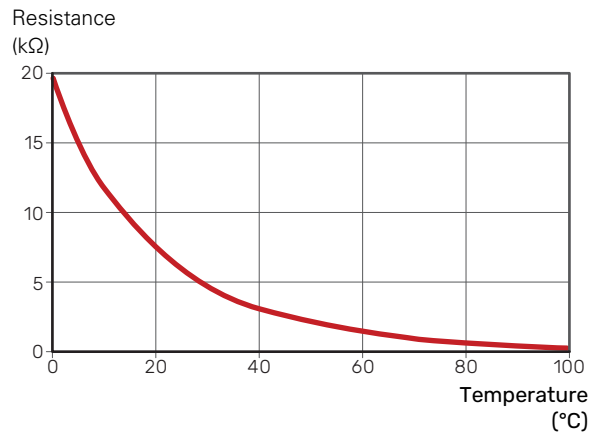

BT28 (Tho-A)

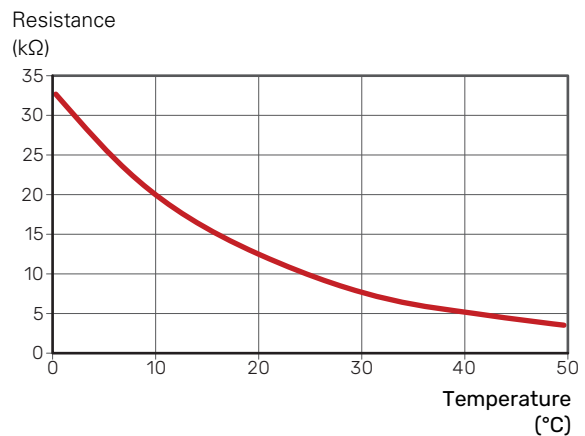

DATA FOR TEMPERATURE SENSOR BT3, BT12, BT15

Temperature (°C)	Resistance (kOhm)	Voltage (VDC)
-10	56.20	3.047
0	33.02	2.889
10	20.02	2.673
20	12.51	2.399
30	8.045	2.083
40	5.306	1.752
50	3.583	1.426
60	2.467	1.136
70	1.739	0.891
80	1.246	0.691

Servicing and maintenance

Important

The NIBE heat pump requires minimal maintenance but to ensure the continued efficient running of your heat pump and guarantee in the warranty period it is recommended that it is checked and serviced annually by a qualified engineer.

Any servicing must be carried out by a competent person.

When replacing a part on the appliance, use only spare parts supplied by NIBE.

If any electrical connections have been disconnected and re-connected, checks for earth continuity must be tested for with a suitable multimeter.

On completion the Benchmark service record should be completed.

General inspection

Check the following:

1. Condition of casing
2. Check Inlet grille is not clogged with leaves
3. Check fan for any obstructions
4. Electrical supply connections
5. Water connections
6. Heating system pressure
7. Alarm log

Correct any fault before continuing.



NOTE

Before removing any covers or replacing parts the heat pump must be isolated from the mains electrical supply.



NOTE

After servicing, complete the relevant Service Interval Record section of the Benchmark Checklist located at the back of this document.

Completion of the Service Interval Record is a condition of warranty. For full terms and conditions of warranty, please see our website nibe.co.uk.

Heating System

1. Inspect start and stop temperatures. Correct if required.
2. Inspect heat curve (SMO & VVM only). Correct if required.
3. Check the heating system flow temperatures, the difference should be between 5–10°C. Adjust flow if required.
4. Inspect the heat pump charge flow temperature difference against charge flow with graphs on page 25. Adjust if required.

Disturbances in comfort

In most cases, the indoor module/control module notes a malfunction (a malfunction can lead to disturbance in comfort) and indicates this with alarms and action instructions in the display.

Troubleshooting



NOTE

In the event of action to rectify malfunctions that require work within screwed hatches, the incoming supply electricity must be isolated at the safety switch by or under the supervision of a qualified electrician.



Caution

Alarms are acknowledged on the indoor module / control module.

If the operational interference is not shown in the display the following tips can be used:

BASIC ACTIONS

Start by checking the following:

- All supply cables to the heat pump are connected.
- Group and main fuses of the accommodation.
- The property's earth circuit breaker.
- The heat pump's fuse / automatic protection. (FC1 / FB1, FB1 only if KVR is installed.)
- The indoor module's/control module's fuses.
- The indoor module's/control module's temperature limiters.
- That the air flow to F2050 is not blocked by foreign objects.
- That F2050 does not have any external damage.

F2050 DOES NOT START

- There is no demand.
 - The indoor module/control module does not call on heating, cooling or hot water.
- Compressor blocked due to the temperature conditions.
 - Wait until the temperature is within the product's working range.
- Minimum time between compressor starts has not been reached.
 - Wait for at least 30 minutes and then check if the compressor has started.
- Alarm tripped.
 - Follow the display instructions.

F2050 NOT COMMUNICATING

- Check that the addressing of F2050 is correct.
- Check that the communication cable is correctly connected and working.

LOW HOT WATER TEMPERATURE OR A LACK OF HOT WATER



Caution

The setting for the hot water is always performed on the indoor module or the control module.

This part of the fault-tracing chapter only applies if the heat pump is docked to the hot water heater.

- Large hot water consumption.
 - Wait until the hot water has heated up.
- Incorrect hot water settings in indoor module or control module.
 - See the Installer Manual for the indoor module/control module.
- Clogged filterball.
 - Switch off the system. Check and clean the filterball.

LOW ROOM TEMPERATURE

- Closed thermostats in several rooms.
 - Set the thermostats to max in as many rooms as possible.
- Incorrect settings in indoor module or control module.
 - See the Installer Manual for the indoor module/control module.
- Air-filled radiators/underfloor heating coils.
 - Bleed the system.

HIGH ROOM TEMPERATURE

- Incorrect settings in indoor module or control module.
 - See the Installer Manual for the indoor module/control module.

LARGE AMOUNT OF WATER BELOW F2050

- The accessory KVR 10 is required.
- If KVR 10 is installed, check that the water drainage can flow freely.

Alarm list

Alarm	Alarm text on the display	Description	May be due to
3	Sensor fault BT3	Sensor fault, Sensor incoming water in F2050 (BT3).	<ul style="list-style-type: none"> Open circuit or short circuit on sensor input Sensor does not work (see section "Disturbances in comfort") Defective control board AA23 in F2050
12	Sensor fault BT12	Sensor fault, Sensor outgoing water in F2050 (BT12).	<ul style="list-style-type: none"> Open circuit or short circuit on sensor input Sensor does not work (see section "Disturbances in comfort") Defective control board AA23 in F2050
15	Sensor fault BT15	Sensor fault, Sensor fluid pipe in F2050 (BT15).	<ul style="list-style-type: none"> Open circuit or short circuit on sensor input Sensor does not work (see section "Disturbances in comfort") Defective control board AA23 in F2050
162	High condenser out	Too high temperature out from the condenser. Self-resetting.	<ul style="list-style-type: none"> Low flow during heating operation Too high set temperatures
163	High condenser in	Too high temperature into the condenser. Self-resetting.	<ul style="list-style-type: none"> Temperature generated by another heat source
183	Defrosting in progress	not an alarm, but an operating status instead.	<ul style="list-style-type: none"> Set when the heat pump runs the defrosting procedure
220	HP alarm	The high pressure switch (63H1) deployed 5 times within 60 minutes or for 60 minutes continuously.	<ul style="list-style-type: none"> Insufficient air circulation or blocked heat exchanger Open circuit or short circuit on input for high pressure switch (63H1) Defective high pressure switch Expansion valve not connected correctly Service valve closed Defective control board in F2050 Low or no flow during heating operation Defective circulation pump Defective fuse, F(4A)
221	LP alarm	Too low value on the low pressure sensor 3 times within 60 minutes.	<ul style="list-style-type: none"> Open circuit or short circuit on input for low pressure sensor Defective low pressure sensor Defective control board in F2050 Open circuit or short circuit on input for suction gas sensor (Tho-S) Defective suction gas sensor (Tho-S)
223	OU Com. error	Communication between the control board and the communication board is interrupted. There must be 22 volt direct current (DC) at the switch CNW2 on the control board (PWB1).	<ul style="list-style-type: none"> Any circuit breakers for F2050 off Incorrect cable routing
224	Fan alarm	Deviations in the fan speed in F2050.	<ul style="list-style-type: none"> The fan cannot rotate freely Defective control board in F2050 Defective fan motor Control board in F2050 dirty Fuse (F2) blown
230	Continuously high hot gas	Temperature deviation on the hot gas sensor (Tho-D) twice within 60 minutes or for 60 minutes continuously.	<ul style="list-style-type: none"> Sensor does not work (see section "Ambient temperature sensor") Insufficient air circulation or heat exchanger Blocked If the fault persists during cooling, there may be an insufficient amount of refrigerant. Defective control board in F2050
254	Communication error	Communication fault with accessory board	<ul style="list-style-type: none"> F2050 not powered Fault in the communication cable.
261	High temperature in heat exchanger	Temperature deviation on the heat exchanger sensor (Tho-R1/R2) five times within 60 minutes or for 60 minutes continuously.	<ul style="list-style-type: none"> Sensor does not work (see section "Disturbances in comfort") Insufficient air circulation or blocked heat exchanger Defective control board in F2050 Too much refrigerant
262	Power transistor too hot	When IPM (Intelligent power module) displays FO-signal (Fault Output) five times during a 60-minute period.	<ul style="list-style-type: none"> Can occur when 15V power supply to the inverter PCB is unstable.
263	Inverter error	Voltage from the inverter outside the parameters four times within 30 minutes.	<ul style="list-style-type: none"> Incoming power supply interference Service valve closed Insufficient amount of refrigerant Compressor fault Defective circuit board for inverter in F2050

Alarm	Alarm text on the display	Description	May be due to
264	Inverter error	Communication between circuit board for inverter and control board broken.	<ul style="list-style-type: none"> • Open circuit in connection between boards • Defective circuit board for inverter in F2050 • Defective control board in F2050
265	Inverter error	Continuous deviation on power transistor for 15 minutes.	<ul style="list-style-type: none"> • Defective fan motor • Defective circuit board for inverter in F2050
266	Not enough refrigerant	Not enough refrigerant is detected on start-up in cooling mode.	<ul style="list-style-type: none"> • Service valve closed • Loose connection sensor (BT15, BT3) • Defective sensor (BT15, BT3) • Too little refrigerant
267	Inverter error	Failed start for compressor	<ul style="list-style-type: none"> • Defective circuit board for inverter in F2050 • Defective control board in F2050 • Compressor fault
268	Inverter error	Overcurrent, Inverter A/F module	<ul style="list-style-type: none"> • Sudden power failure
271	Cold outdoor air	Temperature of BT28 below the value that permits operation	<ul style="list-style-type: none"> • Cold weather conditions • Sensor fault
272	Hot outdoor air	Temperature of BT28 above the value that permits operation	<ul style="list-style-type: none"> • Warm weather conditions • Sensor fault
277	Sensor fault Tho-R	Sensor fault, heat exchanger in F2050(Tho-R).	<ul style="list-style-type: none"> • Open circuit or short circuit on sensor input • Sensor does not work (see section "Disturbances in comfort") • Defective control board in F2050
278	Sensor fault Tho-A	Sensor fault, outdoor temperature sensor in F2050 (Tho-A).	<ul style="list-style-type: none"> • Open circuit or short circuit on sensor input • Sensor does not work (see section "Disturbances in comfort") • Defective control board in F2050
279	Sensor fault Tho-D	Sensor fault, hot gas in F2050 (Tho-D).	<ul style="list-style-type: none"> • Open circuit or short circuit on sensor input • Sensor does not work (see section "Disturbances in comfort") • Defective control board in F2050
280	Sensor fault Tho-S	Sensor fault, suction gas in F2050 (Tho-S).	<ul style="list-style-type: none"> • Open circuit or short circuit on sensor input • Sensor does not work (see section "Disturbances in comfort") • Defective control board in F2050
281	Sensor fault LPT	Sensor fault, low pressure transmitter in F2050.	<ul style="list-style-type: none"> • Open circuit or short circuit on sensor input • Sensor does not work (see section "Disturbances in comfort") • Defective control board in F2050 • Fault in the refrigerant circuit
294	Non-compatible air/water heat pump	Heat pump and indoor module do not function together properly due to technical parameters.	<ul style="list-style-type: none"> • Outdoor module and indoor module are not compatible.
404	Sensor fault BP4	Sensor fault, Sensor high pressure heating/low pressure cooling in F2050 (BP4).	<ul style="list-style-type: none"> • Open circuit or short circuit on sensor input • Sensor does not work (see section "Disturbances in comfort") • Defective control board AA23 in F2050

Accessories

Detailed information about the accessories and complete accessories list available at nibe.co.uk.

Not all accessories are available on all markets.

CONDENSATION WATER PIPE KVR

Condensation water pipe, different lengths.

KVR 10-10

1 metres

Part no. 067 614

KVR 10-30

3 metres

Part no. 067 616

KVR 10-60

6 metres

Part no. 067 618

STAND AND BRACKETS

Ground stand GSU 30

F2050-6, -10

Part no. 067 653

Wall bracket BAU 30

For wall mounting F2050-6, -10

Part no. 067 832

WATER HEATER/ACCUMULATOR TANK

HA-WH5

Megacoil, 160 litre

Art. no G1110001

Megacoil, 200 litre

Art. no G1110002

Megacoil, 300 litre

Art. no G1110003

Megacoil, Solar 200 litre

Art. no G1110004

Megacoil, Solar 300 litre

Art. no G1110005

HOT WATER CONTROL

VST 05

Reversing valve, cu-pipe Ø22
(Max recommended power, 8 kW)

Part no. 089 982

VST 11

Reversing valve, cu-pipe Ø28
(Max recommended power, 17 kW)

Part no. 089 152

Technical data

Dimensions

F2050-6

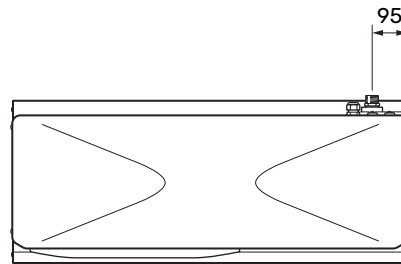
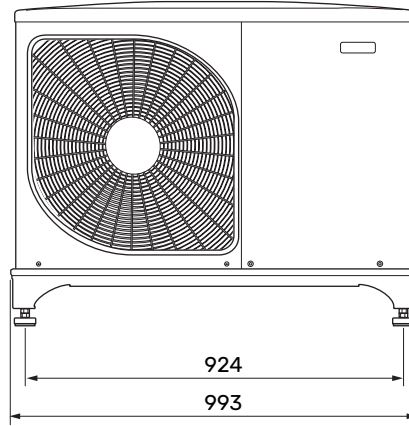
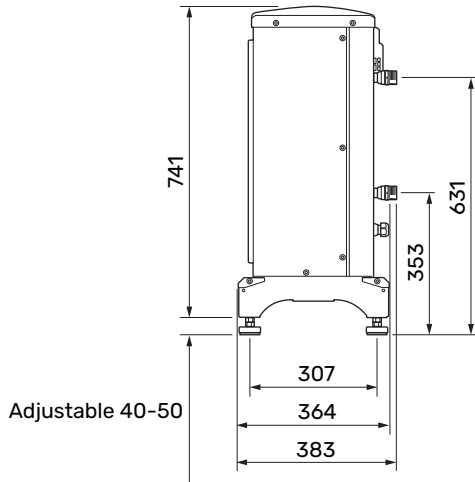

F2050-10

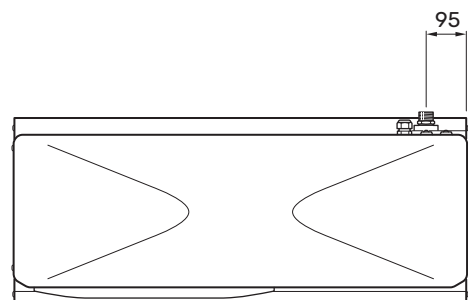
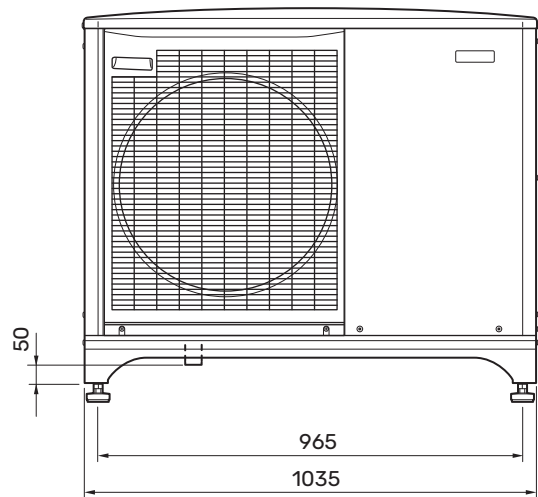
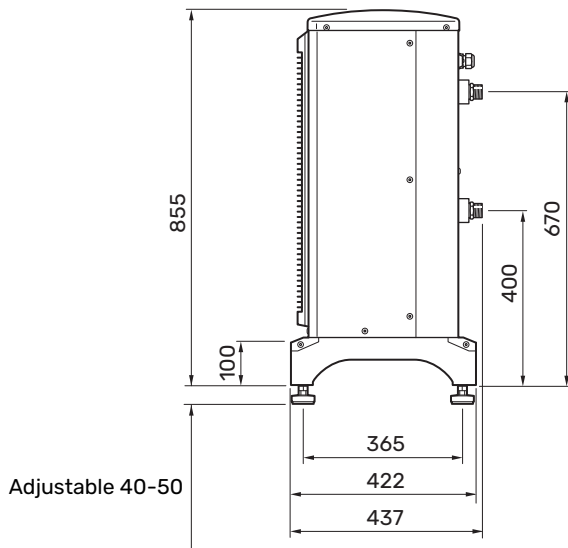

Sound levels

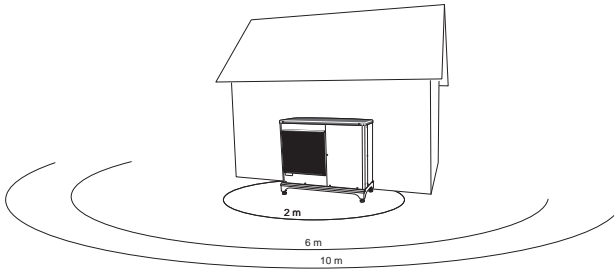

F2050 is usually placed next to a house wall, which gives a directed sound distribution that has to be taken into consideration. Accordingly, when setting up, you should always attempt to select the side that faces the least sound-sensitive neighbouring area.

The sound pressure levels are further affected by walls, bricks, differences in ground level, etc and should therefore only be seen as guide values.

F2050 adjusts the fan speed depending on the ambient temperature and evaporation temperature.

		Sound power ¹	Sound pressure at distance (m) ²									
			1	2	3	4	5	6	7	8	9	10
F2050-6	Nominal sound value	53	48.0	42.0	38.5	36.0	34.0	32.5	31.1	30.0	28.9	28.0
	Max. sound value	62	57.0	51.0	47.5	45.0	43.0	41.5	40.1	39.0	37.9	37.0
	Max. sound value, silent mode	53	48.0	42.0	38.5	36.0	34.0	32.5	31.1	30.0	28.9	28.0
F2050-10	Nominal sound value	53	48.0	42.0	38.5	36.0	34.0	32.5	31.1	30.0	28.9	28.0
	Max. sound value	65	60.0	54.0	50.5	48.0	46.0	44.5	43.1	42.0	40.9	40.0
	Max. sound value, silent mode 60 Hz	53	48.0	42.0	38.5	36.0	34.0	32.5	31.1	30.0	28.9	28.0

¹ Sound power level, $L_w(A)$, according to EN12102

² Sound pressure calculated according to directivity factor $Q=4$

Technical specifications

WORKING RANGE, HEATING

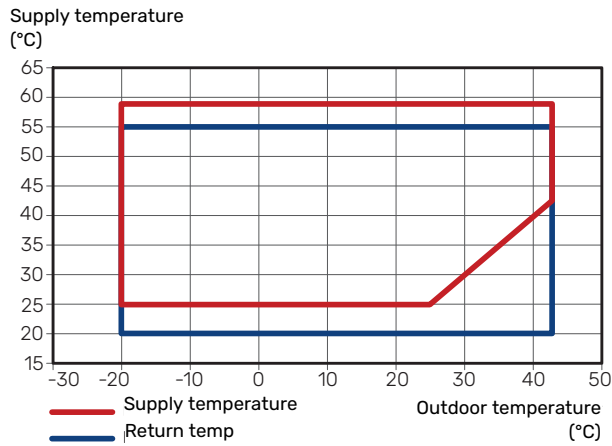

The supply temperature is permitted to be lower for a short period, e.g. at start-up.

WORKING RANGE, COOLING

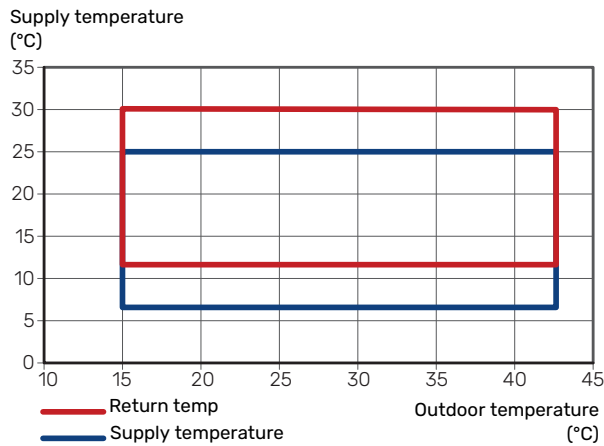

CAPACITY AND COP

Power and COP at different supply temperatures during continuous operation (excluding defrosting).

Power during heating operation

Maximum and minimum capacity during continuous operation.

F2050-6

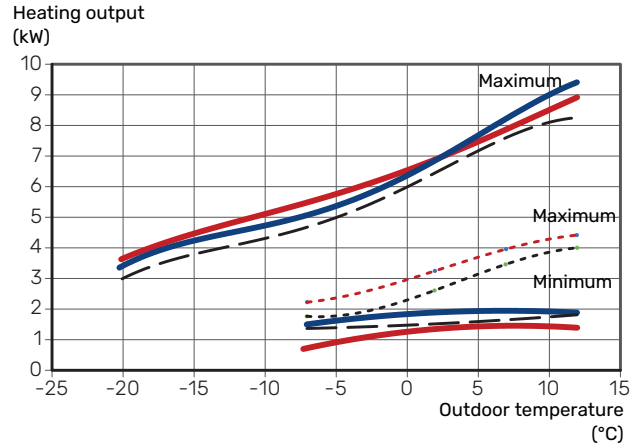

F2050-10

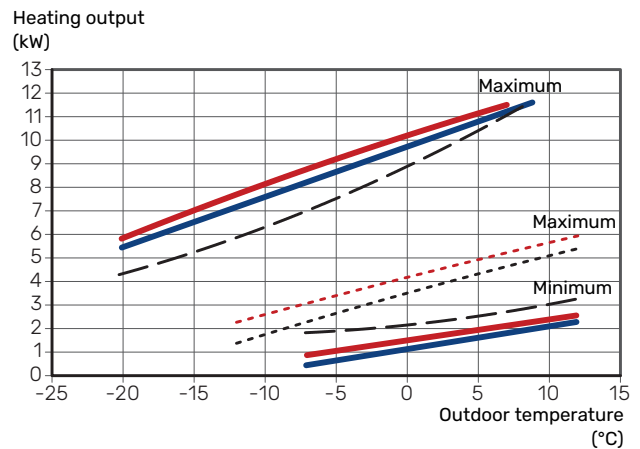

Power during cooling operation

Maximum and minimum capacity during continuous operation.

F2050-6

Cooling output (kW)

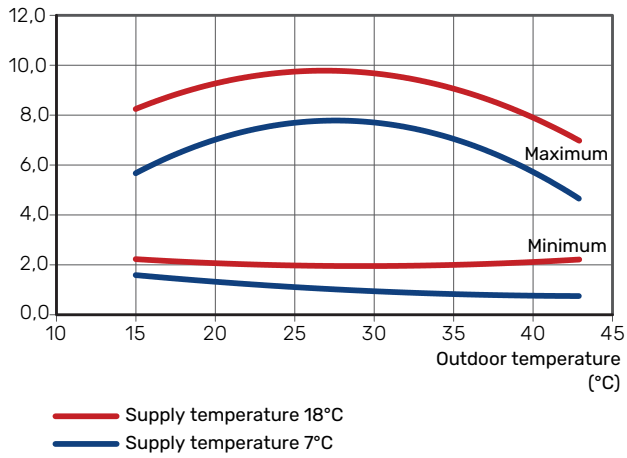

COP during heating operation

F2050-6

COP

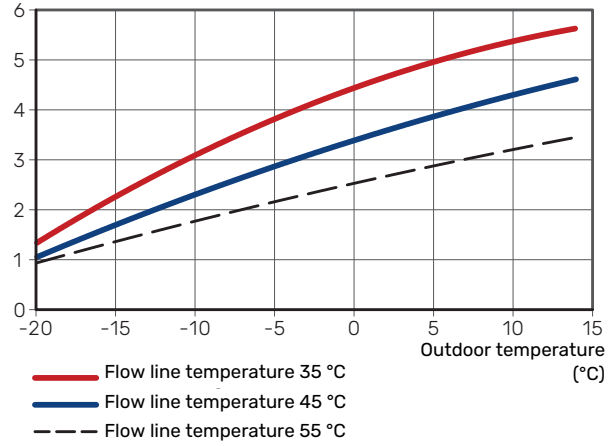

F2050-10

Cooling output (kW)

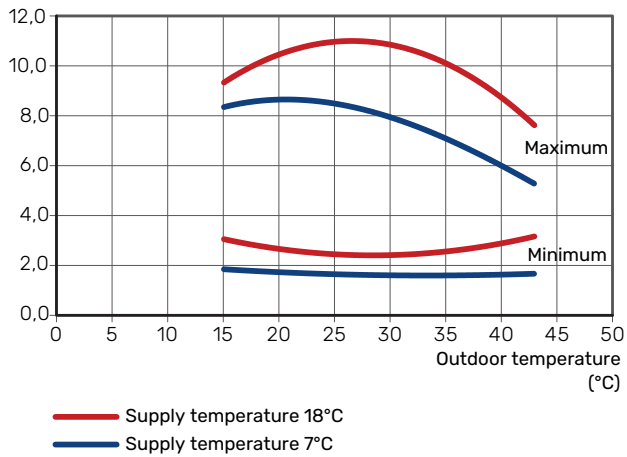

F2050-10

COP

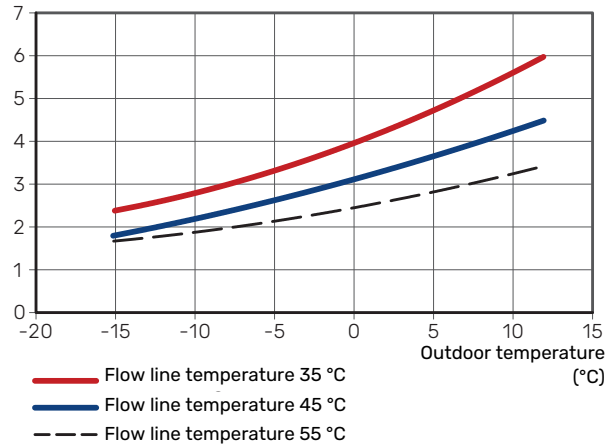

F2050		6	10
Output data according to EN 14 511, partial load¹			
Heating	-7 / 35 °C	5.55 / 2.05 / 2.71	7.18 / 2.93 / 2.45
Capacity / power input / COP (kW/kW/-) at nominal flow	2 / 35 °C	2.31 / 0.56 / 4.13	3.46 / 0.83 / 4.17
Outdoor temp: / Supply temp.	2 / 45 °C	2.02 / 0.67 / 3.01	3.24 / 1.12 / 3.24
	7 / 35 °C	2.65 / 0.49 / 5.41	4.00 / 0.75 / 5.33
	7 / 45 °C	2.43 / 0.65 / 3.74	5.00 / 1.28 / 3.91
Cooling	35 / 7 °C	5.32 / 1.94 / 2.74	7.07 / 2.40 / 2.95
Capacity / power input / EER (kW/kW/-) at maximum flow	35 / 18 °C	7.55 / 2.11 / 3.58	10.79 / 3.00 / 3.60
Outdoor temp: / Supply temp.			
SCOP according to EN 14825			
Nominal heat output (P _{designh}) average climate 35 °C / 55 °C (Europe)	kW	5.20 / 5.60	6.3 / 6.5
Nominal heat output (P _{designh}) cold climate 35 °C / 55 °C	kW	5.80 / 5.70	6.5 / 6.2
Nominal heat output (P _{designh}) warm climate 35 °C / 55 °C	kW	5.57 / 5.48	6.9 / 6.6
SCOP average climate, 35 °C / 55 °C (Europe)		5.08 / 3.58	4.6 / 3.4
SCOP cold climate, 35 °C / 55 °C		4.10 / 3.05	3.9 / 2.9
SCOP warm climate, 35 °C / 55 °C		6.76 / 4.55	6.4 / 4.4
Energy rating, average climate²			
The product's room heating efficiency class 35 °C / 55 °C ³		A+++ / A++	A++ / A++
The system's room heating efficiency class 35 °C / 55 °C ⁴		A+++ / A++	
Electrical data			
Rated voltage		230 V ~ 50 Hz, 230 V 2 ~ 50 Hz	
Max operating current, heat pump	A _{rms}	15	16
Max operating current, compressor	A _{rms}	14	15
Max. power, fan	W	50	86
Fuse	A _{rms}	16	16
Enclosure class		IP24	
Refrigerant circuit			
Type of refrigerant		R32	
GWP refrigerant		675	
Volume	kg	1.3	1.84
Type of compressor		Twin Rotary	
CO ₂ -equivalent (The cooling circuit is hermetically sealed.)	t	0.88	1.24
Cut-out value pressure switch HP (BP1)	MPa (bar)	-	4.15 (41.5)
Cut-out value pressure switch LP (BP2)	MPa (bar)	-	0.079 (0.79)
Airflow			
Max airflow	m ³ /h	2,530	3,000
Working area			
Min./max. air temperature, heating	°C	-20 / 43	-20 / 43
Min./max. air temperature, cooling	°C	15 / 43	
Defrosting system		Reverse cycle	
Heating medium circuit			
Max system pressure heating medium	MPa (bar)	0.6 (6.0)	
Recommended flow interval, heating operation	l/s	0.08 – 0.32	0.12 – 0.38
Recommended flow interval, cooling operation	l/s	0.11 – 0.29	0.15 – 0.38
Min. design flow, defrosting (100% pump speed)	l/s	0.19	
Min./max. HM temp, continuous operation	°C	25 / 58	
Connection heating medium F2050 external thread		G1 (Ø28 mm)	
Connection heating medium flex pipe		G1 (Ø28 mm)	
Min. recommended pipe dimension (system)	DN (mm)	20 (22)	
Dimensions and weight			
Width	mm	993	1,035
Depth	mm	383	422
Height (with stand)	mm	781 (+10/-0)	895 (+10/-0)
Net weight	kg	76	83
Miscellaneous			
Part no.		064 328	064 318

1 Power statements including defrosting according to EN 14511 at heating medium supply corresponding to DT=5 K at 7 / 45.

2 Reported efficiency for the system also takes the temperature regulator into account. If the system is supplemented with an external auxiliary boiler or solar heating, the total efficiency of the system must be recalculated.

3 Scale for the product's room heating efficiency class A++ to G. Control module model SMO S

4 Scale for the system's room heating efficiency class A+++ to G. Control module model SMO S

Energy labelling

INFORMATION SHEET

Supplier		NIBE	
Model		F2050-6	F2050-10
Temperature application	°C	35 / 55	35 / 55
Seasonal space heating energy efficiency class, average climate		A+++ / A++	A+++ / A++
Rated heat output ($P_{\text{design,h}}$), average climate	kW	5 / 6	6 / 6
Annual energy consumption space heating, average climate	kWh	2,116 / 3,250	2,834 / 3,961
Seasonal space heating energy efficiency, average climate	%	200 / 139	181 / 132
Sound power level L_{WA} indoors	dB	-	-
Rated heat output ($P_{\text{design,h}}$), cold climate	kW	6 / 6	7 / 6
Rated heat output ($P_{\text{design,h}}$), warm climate	kW	6 / 5	7 / 7
Annual energy consumption space heating, cold climate	kWh	3,487 / 4,604	4,059 / 5,204
Annual energy consumption space heating, warm climate	kWh	1,110 / 1,617	1,379 / 1,964
Seasonal space heating energy efficiency, cold climate	%	161 / 119	155 / 114
Seasonal space heating energy efficiency, warm climate	%	265 / 178	260 / 177
Sound power level L_{WA} outdoors	dB	53	53

DATA FOR ENERGY EFFICIENCY OF THE PACKAGE

Model		F2050-6	F2050-10
Control module model		SMO	SMO
Temperature application	°C	35 / 55	35 / 55
Controller, class		VI	
Controller, contribution to efficiency	%	4.0	
Seasonal space heating energy efficiency of the package, average climate	%	204 / 143	185 / 136
Seasonal space heating energy efficiency class of the package, average climate		A+++ / A++	A+++ / A++
Seasonal space heating energy efficiency of the package, cold climate	%	165 / 123	159 / 118
Seasonal space heating energy efficiency of the package, warm climate	%	269 / 182	264 / 181

The reported efficiency of the package also takes the controller into account. If an external supplementary boiler or solar heating is added to the package, the overall efficiency of the package should be recalculated.

TECHNICAL DOCUMENTATION

Model				F2050-6			
Type of heat pump	<input checked="" type="checkbox"/> Air-water <input type="checkbox"/> Exhaust-water <input type="checkbox"/> Brine-water <input type="checkbox"/> Water-water						
Low-temperature heat pump	<input type="checkbox"/> Yes <input checked="" type="checkbox"/> No						
Integrated immersion heater for additional heat	<input type="checkbox"/> Yes <input checked="" type="checkbox"/> No						
Heat pump combination heater	<input type="checkbox"/> Yes <input checked="" type="checkbox"/> No						
Climate	<input checked="" type="checkbox"/> Average <input type="checkbox"/> Cold <input type="checkbox"/> Warm						
Temperature application	<input checked="" type="checkbox"/> Medium (55°C) <input type="checkbox"/> Low (35°C)						
Applied standards	EN14511 / EN14825 / EN12102						
Rated heat output	Prated	5.6	kW	Seasonal space heating energy efficiency	η_s	139	%
Declared capacity for space heating at part load and at outdoor temperature T_j				Declared coefficient of performance for space heating at part load and at outdoor temperature T_j			
$T_j = -7\text{ °C}$	Pdh	5.0	kW	$T_j = -7\text{ °C}$	COPd	1.95	-
$T_j = +2\text{ °C}$	Pdh	2.9	kW	$T_j = +2\text{ °C}$	COPd	3.51	-
$T_j = +7\text{ °C}$	Pdh	1.9	kW	$T_j = +7\text{ °C}$	COPd	4.99	-
$T_j = +12\text{ °C}$	Pdh	1.7	kW	$T_j = +12\text{ °C}$	COPd	6.33	-
$T_j = \text{biv}$	Pdh	5.0	kW	$T_j = \text{biv}$	COPd	1.95	-
$T_j = \text{TOL}$	Pdh	4.6	kW	$T_j = \text{TOL}$	COPd	1.75	-
$T_j = -15\text{ °C}$ (if TOL < -20 °C)	Pdh		kW	$T_j = -15\text{ °C}$ (if TOL < -20 °C)	COPd		-
Bivalent temperature	T_{biv}	-7	°C	Min. outdoor air temperature	TOL	-10	°C
Cycling interval capacity	P _{cy}		kW	Cycling interval efficiency	COP _{cy}		-
Degradation coefficient	Cdh	0.96	-	Max supply temperature	WTOL	58	°C
Power consumption in modes other than active mode				Additional heat			
Off mode	P _{OFF}	0.007	kW	Rated heat output	P _{sup}	1.0	kW
Thermostat-off mode	P _{TO}	0.011	kW				
Standby mode	P _{SB}	0.011	kW	Type of energy input	Electric		
Crankcase heater mode	P _{CK}	0.000	kW				
<i>Other items</i>							
Capacity control	Variable			Rated airflow (air-water)		2,340	m ³ /h
Sound power level, indoors/outdoors	L _{WA}	- / 53	dB	Nominal heating medium flow			m ³ /h
Annual energy consumption	Q _{HE}	3,250	kWh	Brine flow brine-water or water-water heat pumps			m ³ /h
Contact information	NIBE Energy Systems - Box 14 - Hannabadsvägen 5 - 285 21 Markaryd - Sweden						

Model		F2050-10							
Type of heat pump	<input checked="" type="checkbox"/> Air-water <input type="checkbox"/> Exhaust-water <input type="checkbox"/> Brine-water <input type="checkbox"/> Water-water								
Low-temperature heat pump	<input type="checkbox"/> Yes <input checked="" type="checkbox"/> No								
Integrated immersion heater for additional heat	<input type="checkbox"/> Yes <input checked="" type="checkbox"/> No								
Heat pump combination heater	<input type="checkbox"/> Yes <input checked="" type="checkbox"/> No								
Climate	<input checked="" type="checkbox"/> Average <input type="checkbox"/> Cold <input type="checkbox"/> Warm								
Temperature application	<input checked="" type="checkbox"/> Medium (55°C) <input type="checkbox"/> Low (35°C)								
Applied standards	EN14511 / EN14825 / EN12102								
Rated heat output	Prated	6.5	kW	Seasonal space heating energy efficiency	η_s	132	%		
Declared capacity for space heating at part load and at outdoor temperature T_j				Declared coefficient of performance for space heating at part load and at outdoor temperature T_j					
$T_j = -7\text{ °C}$	Pdh	5.8	kW	$T_j = -7\text{ °C}$	COPd	1.98	-		
$T_j = +2\text{ °C}$	Pdh	3.5	kW	$T_j = +2\text{ °C}$	COPd	3.17	-		
$T_j = +7\text{ °C}$	Pdh	2.3	kW	$T_j = +7\text{ °C}$	COPd	4.98	-		
$T_j = +12\text{ °C}$	Pdh	2.2	kW	$T_j = +12\text{ °C}$	COPd	5.50	-		
$T_j = \text{biv}$	Pdh	5.8	kW	$T_j = \text{biv}$	COPd	1.98	-		
$T_j = \text{TOL}$	Pdh	5.8	kW	$T_j = \text{TOL}$	COPd	1.69	-		
$T_j = -15\text{ °C}$ (if TOL < -20 °C)	Pdh		kW	$T_j = -15\text{ °C}$ (if TOL < -20 °C)	COPd		-		
Bivalent temperature	T_{biv}	-7	°C	Min. outdoor air temperature	TOL	-10	°C		
Cycling interval capacity	P _{cy}		kW	Cycling interval efficiency	COP _{cy}		-		
Degradation coefficient	Cdh	0.98	-	Max supply temperature	WTOL	60	°C		
Power consumption in modes other than active mode				Additional heat					
Off mode	P _{OFF}	0.003	kW	Rated heat output	P _{sup}	0.7	kW		
Thermostat-off mode	P _{TO}	0.008	kW						
Standby mode	P _{SB}	0.008	kW	Type of energy input	Electric				
Crankcase heater mode	P _{CK}	0.000	kW						
Other items									
Capacity control	Variable			Rated airflow (air-water)		3,000	m ³ /h		
Sound power level, indoors/outdoors	L _{WA}	- / 53	dB	Nominal heating medium flow			m ³ /h		
Annual energy consumption	Q _{HE}	3,961	kWh	Brine flow brine-water or water-water heat pumps			m ³ /h		
Contact information	NIBE Energy Systems – Box 14 – Hannabadsvägen 5 – 285 21 Markaryd – Sweden								

Electrical circuit diagram

F2050-6

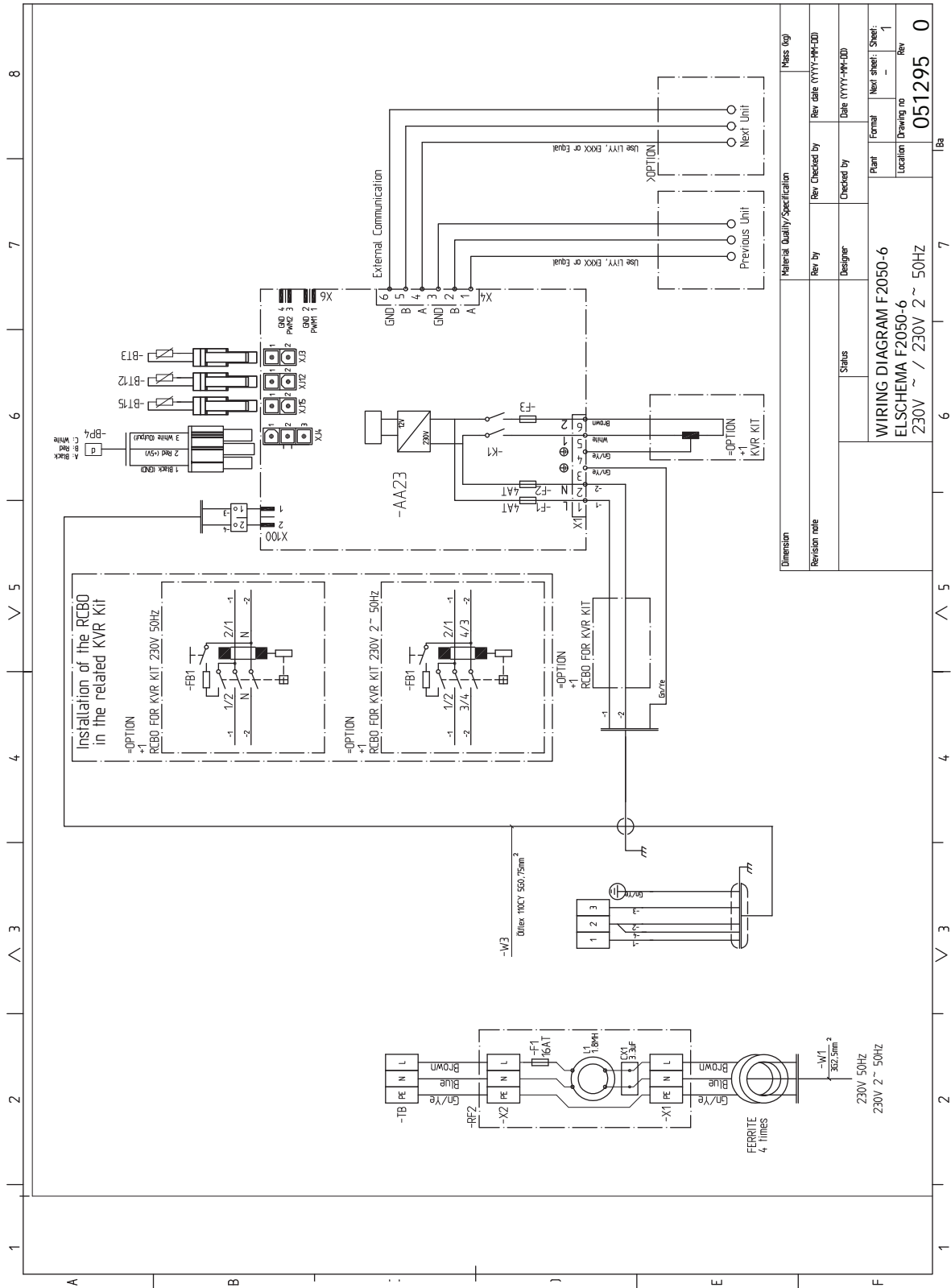

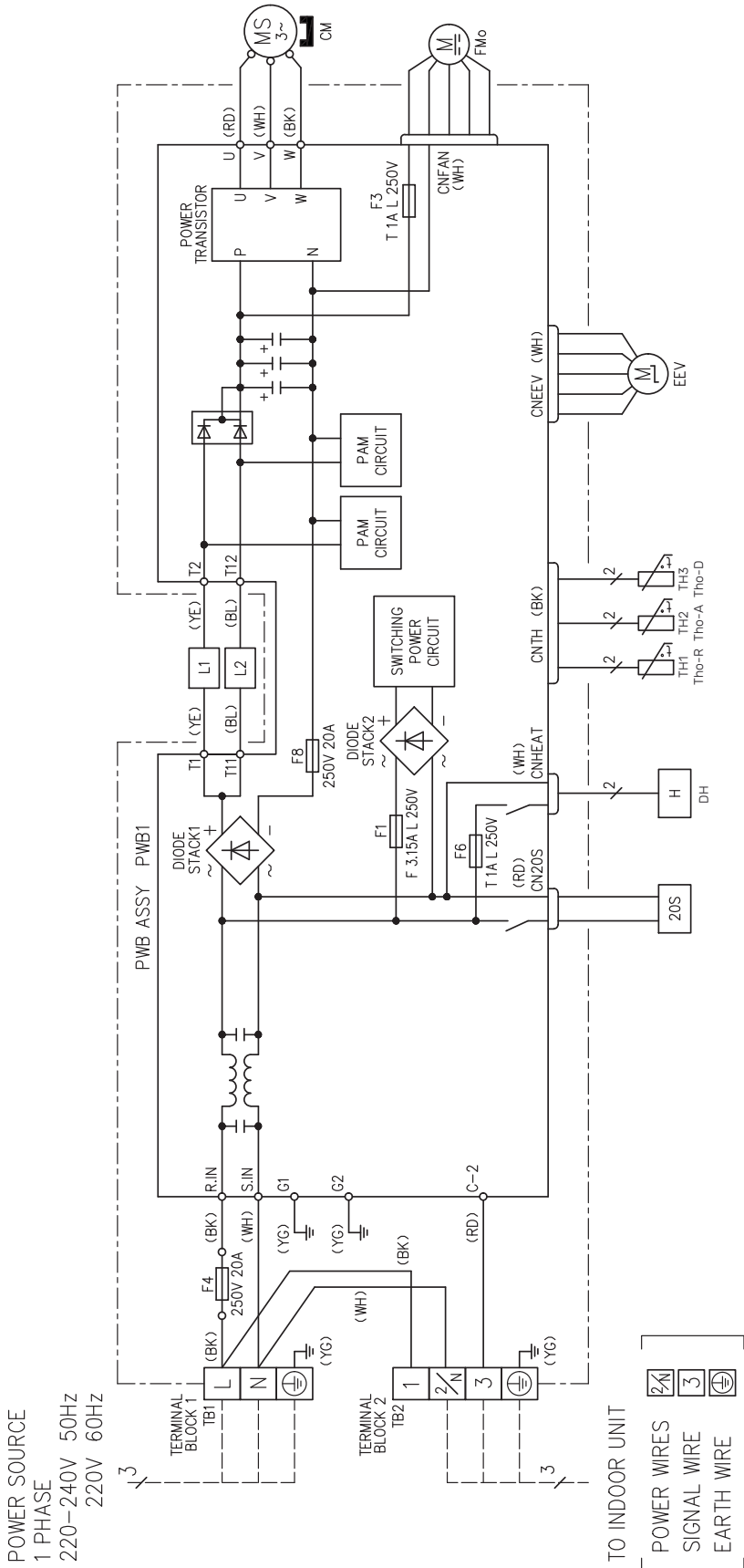

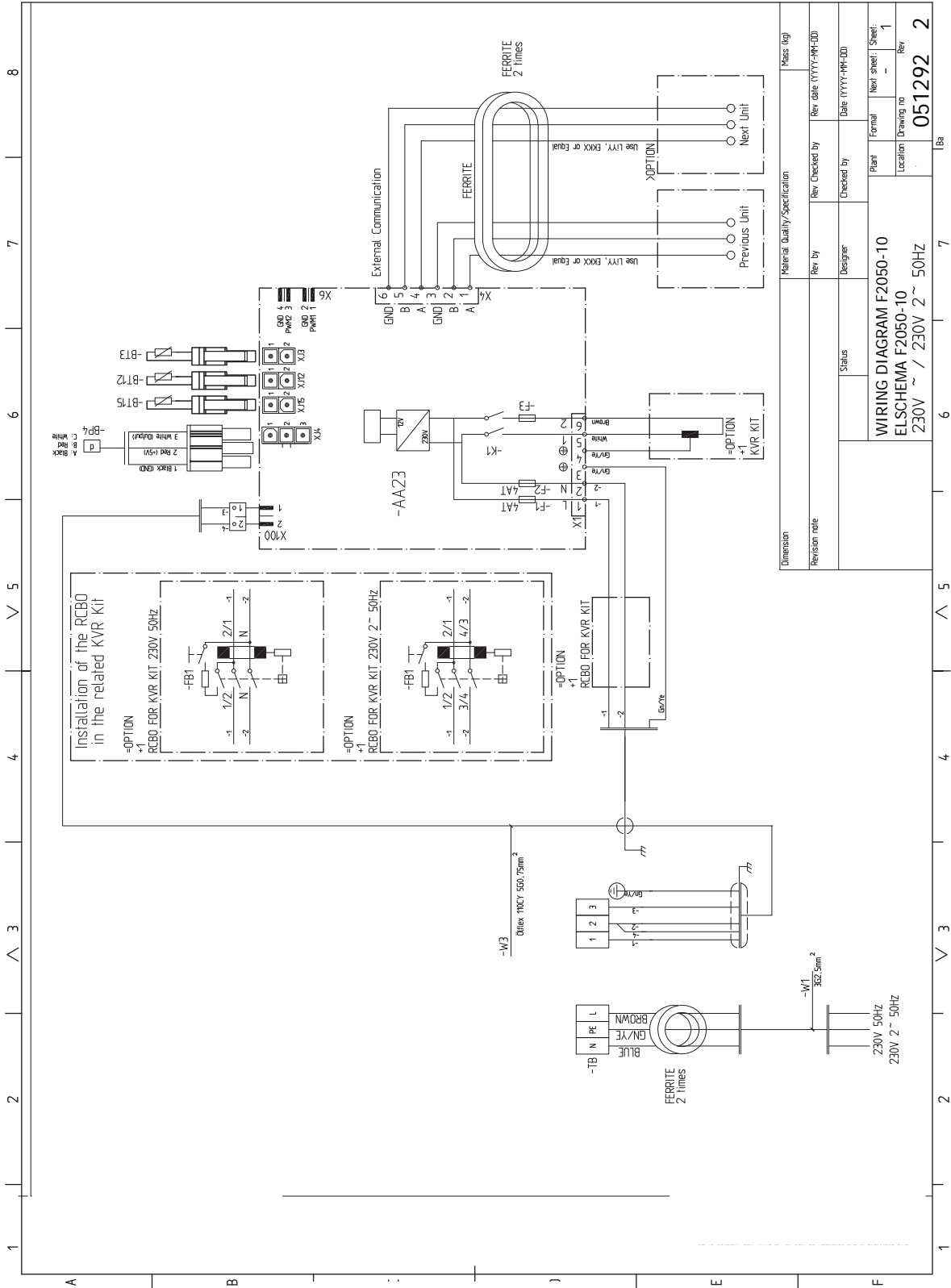

Material Quality/Specification		Mess (vgl)	
Revision note	Dimension	Rev. Checked by	Rev. date (YYYY-MM-DD)
Status		Designer	Checked by
WIRING DIAGRAM F2050-10		Plant	Formal
ELSCHEMA F2050-10		Location	Drawing no
230V ~ / 230V 2~ 50Hz		Rev	051292 2

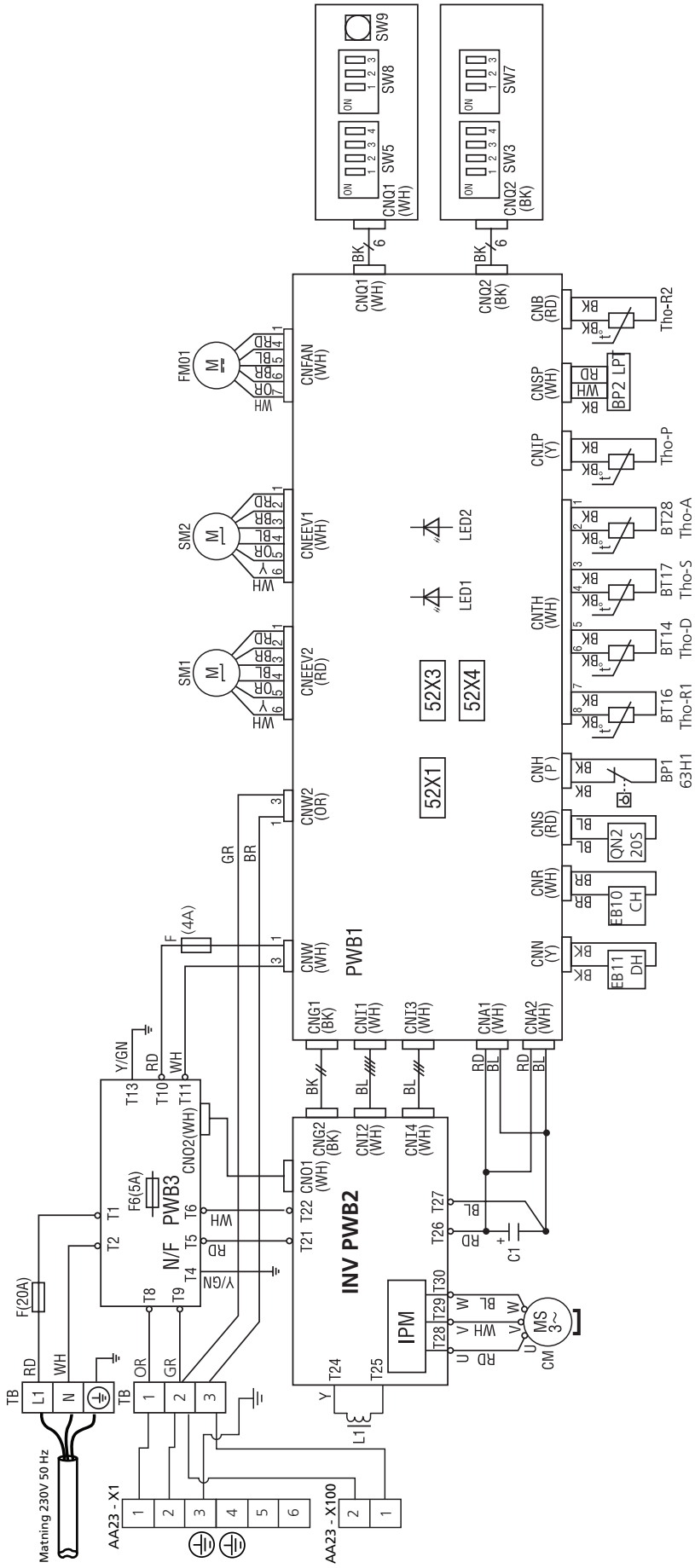

Item register

- A**
 - Accessories, 41
 - Addressing via cascade connection, 31
 - Adjustment, charge flow, 33
 - Alarm list, 39
 - Ambient temperature sensor, 29
 - Areas with hard water, 23
 - Assembly, 8
- B**
 - Basic actions, 38
- C**
 - Cascade connection, 31
 - Charge pump, 24
 - Cleaning the climate system, 23
 - Commissioning and adjusting, 32
 - Adjustment, charge flow, 33
 - Compressor heater, 32
 - Filling and venting the heating medium system, 32
 - Preparations, 32
 - Readjusting, heating medium side, 33
 - Start-up and inspection, 33
 - Communication, 30
 - Compatible indoor modules and control modules, 7
 - Component placement
 - Sensor placement, 20
 - Compressor heater, 32
 - Condensation, 10
 - Connecting accessories, 25
 - Connections, 27
 - Connection to board (AA23, 21)
 - Connection to board (PWB1), 20
 - Connection to control module, 30
 - Connection to indoor module, 30
 - Control
 - Control - Heat pump (EB101), 34
 - Control - Heat pump (EB101), 34
 - Control - Heat pump EB101, 34
 - Control - Heat pump EB101
 - Heat pump settings - Menu 7.3.2, 34-35
 - Country specific information, 5
- D**
 - Delivery and handling, 8
 - Assembly, 8
 - Condensation, 10
 - Dismantling panels, 12
 - Installation area, 10
 - Supplied components, 11
 - Transport, 8
 - Dimensions and setting-out coordinates, 42
 - Dismantling panels, 12
 - Dismantling top panel, 12
 - Disruption to comfort
 - Temperature sensor data, 36
 - Disturbances in comfort, 38
 - Alarm list, 39
 - Troubleshooting, 38
 - Docking alternatives, 25
- E**
 - Electrical circuit diagram, 50
 - Electrical connection, 18
 - Electrical connections, 26
 - Addressing via cascade connection, 31
 - Ambient temperature sensor, 29
 - Cascade connection, 31
 - Communication, 30
 - Connecting accessories, 25
 - Connections, 27
 - Connection to control module, 30
 - Connection to indoor module, 30
 - External heating cable (KVR 10) , 29
 - General, 26
 - Power connection, 27
 - Software version, 30
 - Energy labelling, 47
 - Data for energy efficiency of the package, 47
 - Information sheet, 47
 - Technical documentation, 48
 - External heating cable (KVR 10) , 29
- F**
 - F2050 does not start, 38
 - F2050 not communicating, 38
 - Filling and venting the heating medium system, 32
- G**
 - General, 26
- H**
 - Heat pump settings - Menu 7.3.2, 34-35
 - High room temperature, 38
- I**
 - Important information, 4
 - Compatible indoor modules and control modules, 7
 - Country specific information, 5
 - Inspection of the installation, 6
 - Safety information, 4
 - Serial number, 4
 - Inspection of the installation, 6
 - Installation area, 10
 - Installing the installation
 - Symbol key, 24
- L**
 - Large amount of water below F2050, 38
 - List of components, 17
 - Low hot water temperature or no hot water, 38
 - Low room temperature, 38
- M**
 - Marking, 4
- P**
 - Pipe connections, 23
 - Charge pump, 24
 - Docking alternatives, 25
 - General, 23
 - Areas with hard water, 23
 - Cleaning the climate system, 23
 - Pipe connections flex hose, 25
 - Pipe coupling, heating medium, 24
 - Pressure drop, heating medium side, 25
 - Symbol key, 24
 - Water volumes, 23
 - Pipe connections flex hose, 25
 - Pipe coupling, heating medium, 24
 - Power connection, 27

- Preparations, 32
- Pressure drop, heating medium side, 25
- R**
- Readjusting, heating medium side, 33
- Removing the front panel, 13
- S**
- Safety information, 4
 - Marking, 4
 - Symbols, 4
 - Warranty information, 5
- Sensor placement, 20
 - Connection to board (AA23), 21
 - Connection to board (PWB1), 20
 - Sensor placement in F2050, 22
 - Sensors etc., 22
- Sensor placement in F2050, 22
- Sensors etc., 22
- Serial number, 4
- Service, 36
- Service actions
 - Temperature sensor data, 36
- Software version, 30
- Sound levels, 43
- Start-up and inspection, 33
- Supplied components, 11
- Symbol key, 24
- Symbols, 4
- T**
- Technical data, 42
 - Dimensions and setting-out coordinates, 42
 - Electrical circuit diagram, 50
 - Sound pressure levels, 43
 - Technical Data, 44
- Technical Data, 44
- Temperature sensor data, 36
- The heat pump design, 14
 - Component locations, 14
 - Electrical components, 19
 - Electrical connection, 18
 - List of components, 17
- Transport, 8
- Troubleshooting, 38
 - Basic actions, 38
 - F2050 does not start, 38
 - F2050 not communicating, 38
 - High room temperature, 38
 - Large amount of water below F2050, 38
 - Low hot water temperature or no hot water, 38
 - Low room temperature, 38
- W**
- Warranty information, 5

AIR TO WATER HEAT PUMP COMMISSIONING CHECKLIST

This Commissioning Checklist is to be completed in full by the competent person who commissioned the heat pump and associated equipment as a means of demonstrating compliance with the appropriate Building Regulations and then handed to the customer to keep for future reference.

Failure to install and commission this equipment to the manufacturer's instructions may invalidate the warranty but does not affect statutory rights.

Customer Name _____

Address _____

Telephone Number _____

Heat Pump Make and Model _____

Heat Pump Serial Number _____

Commissioned by (print name) _____

Certified Operative Reg. No. ^[1] _____

Company Name & Address _____

Commissioning Date _____

Telephone No. _____

Building Regulations Notification Number (if applicable) ^[2] _____

CONTROLS - SYSTEM AND HEAT PUMP

Tick the appropriate boxes if applicable

- | | | | | |
|--|---|--|---|--|
| 1. Time & Temperature Control to Heating | Room Thermostat & Programmer/Timer <input type="checkbox"/> | Programmable Roomstat <input type="checkbox"/> | Load/Weather Compensation <input type="checkbox"/> | Optimum Start Control <input type="checkbox"/> |
| 2. Time & Temperature Control to Hot Water | | | Cylinder Thermostat & Programmer/Timer <input type="checkbox"/> | Combined with Heat pump main controls <input type="checkbox"/> |
| 3. Heating Zone Valves | | | Fitted <input type="checkbox"/> | Not Required <input type="checkbox"/> |
| 4. Hot Water Zone Valves | | | Fitted <input type="checkbox"/> | Not Required <input type="checkbox"/> |
| 5. Thermostatic Radiator Valves | | | Fitted <input type="checkbox"/> | Not Required <input type="checkbox"/> |
| 6. Heat Pump Safety Interlock ^[3] | | | | Provided <input type="checkbox"/> |
| 7. Outdoor Sensor | | | Fitted <input type="checkbox"/> | Not Required <input type="checkbox"/> |
| 8. Automatic Bypass System | | | Fitted <input type="checkbox"/> | Not Required <input type="checkbox"/> |
| 9. Buffer Vessel Fitted | Yes <input type="checkbox"/> | No <input type="checkbox"/> | If YES, | Volume <input type="text"/> Litres |

ALL SYSTEMS

- The heating system has been filled and pressure tested Yes
- Expansion vessel for heating is sized, fitted & charged in accordance with manufacturer's instructions Yes
- The heat pump is fitted on a solid/stable surface capable of taking its weight Yes
- The system has been flushed and cleaned in accordance with BS7593 and heat pump manufacturer's instructions Yes
- What system cleaner was used? _____
- What inhibitor was used? _____ Qty litres
- Is the system adequately frost protected? Yes

OUTDOOR COLLECTOR

- Are all external pipeworks insulated? Yes
- Is the fan free from obstacles and operational? Yes
- Has suitable consideration been made for waste water discharge? Yes

CENTRAL HEATING MODE

Heating Flow Temperature °C

Heating Return Temperature °C

DOMESTIC HOT WATER MODE

- Is the heat pump connected to a hot water cylinder? Unvented Vented Thermal Store Not Connected Yes
- Hot water has been checked at all outlets Yes

ADDITIONAL SYSTEM INFORMATION

Additional heat sources connected

- Gas Boiler Oil Boiler Electric Heater Other _____

ALL INSTALLATIONS

- The heating, hot water and ventilation systems comply with the appropriate Building Regulations Yes
- All electrical work complies with the appropriate Regulations Yes
- The heat pump and associated products have been installed and commissioned in accordance with the manufacturer's instructions Yes
- The operation of the heat pump and system controls have been demonstrated to the customer Yes
- The manufacturer's literature, including Benchmark Checklist and Service Record, has been explained and left with the customer Yes

Commissioning Engineer's Signature _____

Customer's Signature _____

(To confirm demonstration of equipment and receipt of appliance instructions)

Notes: ^[1] Installers should be members of an appropriate Competent Persons Scheme. ^[2] All installations in England and Wales must be notified to Local Area Building Control (LABC) either directly or through a Competent Persons Scheme. A Building Regulations Compliance Certificate will then be issued to the customer. ^[3] May be required for systems covered by G3 Regulations

Service Record

It is recommended that your heating system is serviced regularly and that the appropriate Service Interval Record is completed.

Service Provider

Before completing the appropriate Service Interval Record below, please ensure you have carried out the service as described in the manufacturer's instructions.

Always use the manufacturer's specified spare part when replacing controls.

Service 1 Date: _____

Engineer Name: _____

Company Name: _____

Telephone No. _____

Operative ID No. _____

Comments: _____

Signature: _____

Service 2 Date: _____

Engineer Name: _____

Company Name: _____

Telephone No. _____

Operative ID No. _____

Comments: _____

Signature: _____

Service 3 Date: _____

Engineer Name: _____

Company Name: _____

Telephone No. _____

Operative ID No. _____

Comments: _____

Signature: _____

Service 4 Date: _____

Engineer Name: _____

Company Name: _____

Telephone No. _____

Operative ID No. _____

Comments: _____

Signature: _____

Service 5 Date: _____

Engineer Name: _____

Company Name: _____

Telephone No. _____

Operative ID No. _____

Comments: _____

Signature: _____

Service 6 Date: _____

Engineer Name: _____

Company Name: _____

Telephone No. _____

Operative ID No. _____

Comments: _____

Signature: _____

Service 7 Date: _____

Engineer Name: _____

Company Name: _____

Telephone No. _____

Operative ID No. _____

Comments: _____

Signature: _____

Service 8 Date: _____

Engineer Name: _____

Company Name: _____

Telephone No. _____

Operative ID No. _____

Comments: _____

Signature: _____

Service 9 Date: _____

Engineer Name: _____

Company Name: _____

Telephone No. _____

Operative ID No. _____

Comments: _____

Signature: _____

Service 10 Date: _____

Engineer Name: _____

Company Name: _____

Telephone No. _____

Operative ID No. _____

Comments: _____

Signature: _____

NIBE Energy Systems Ltd
3C Broom Business Park,
Bridge Way, S41 9QG Chesterfield
Tel: +44 (0)330 311 2201
info@nibe.co.uk
nibe.co.uk

IHB EN 2318-2 631412

This is a publication from NIBE Energy Systems. All product illustrations, facts and data are based on the available information at the time of the publication's approval.

NIBE Energy Systems makes reservations for any factual or printing errors in this publication.

©2023 NIBE ENERGY SYSTEMS

