

HRV unit

NIBE ERS 20

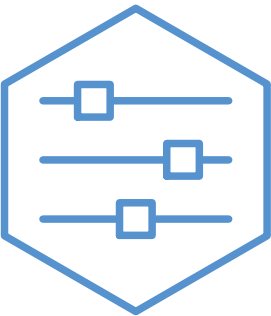

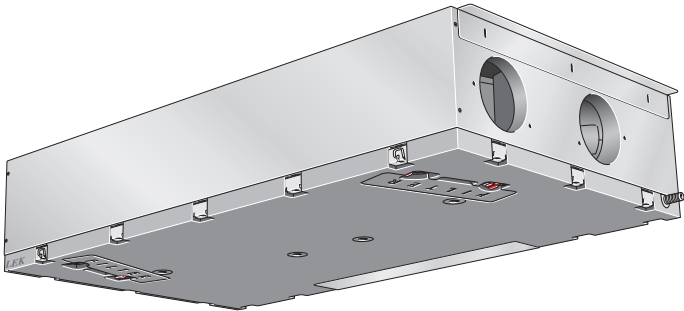
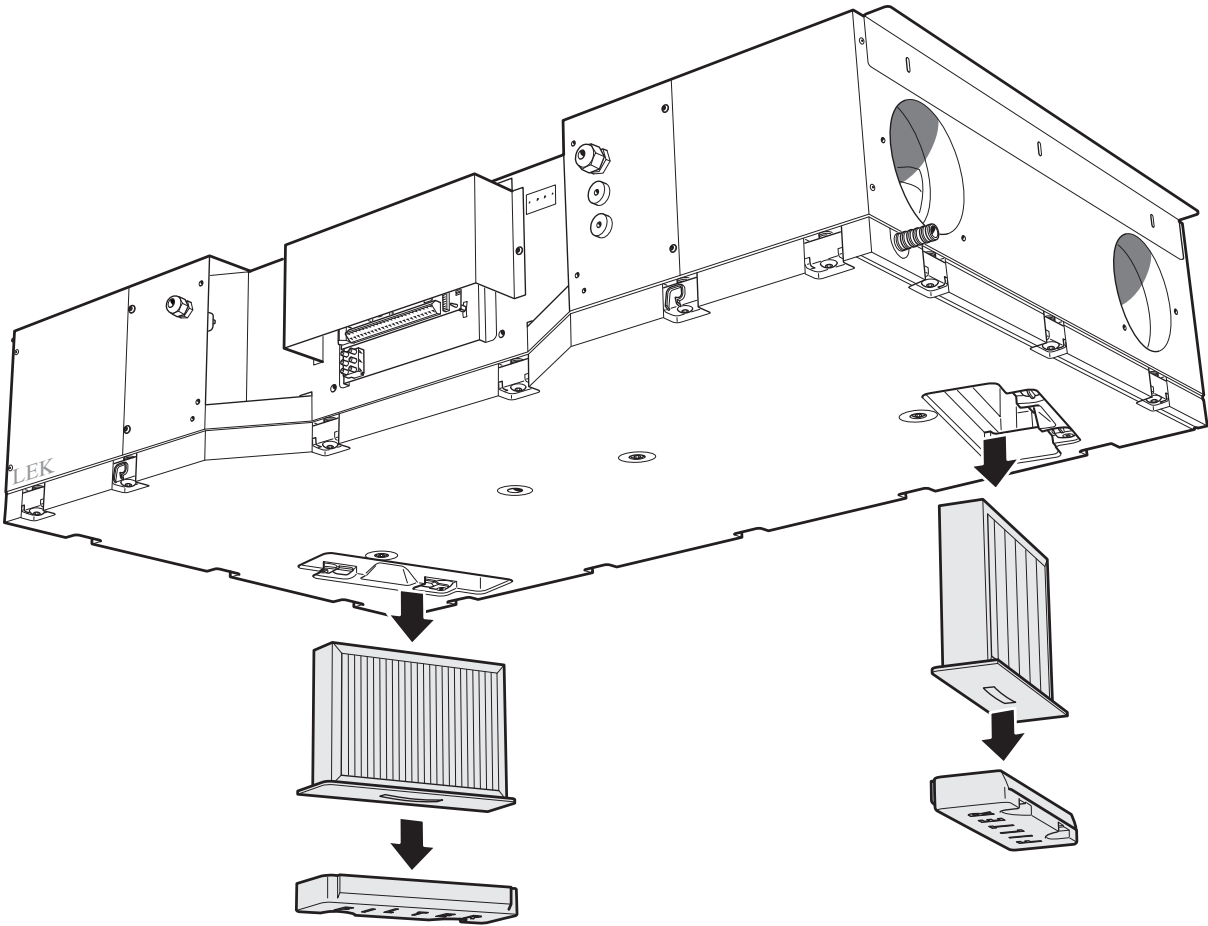
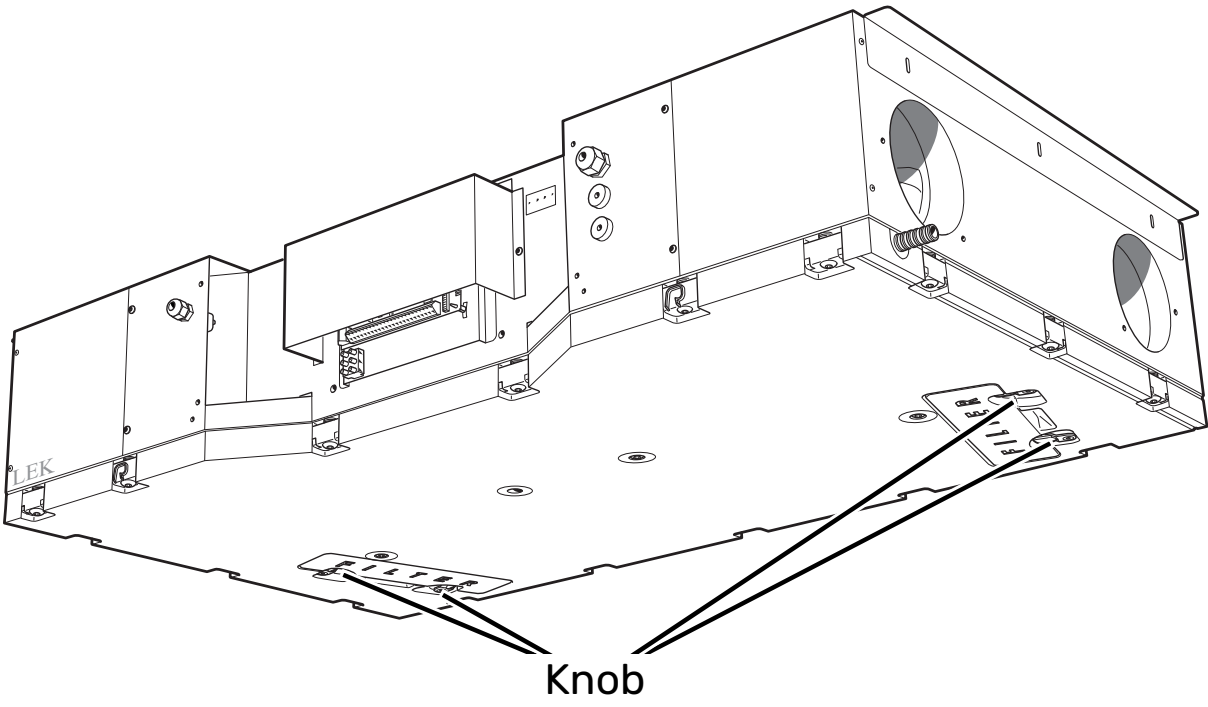

Table of Contents

1	Important information _____	4
	Installation data _____	4
	Safety information _____	5
	Serial number _____	5
	Compatible products _____	5
2	Function of the HRV unit _____	6
3	Maintenance of ERS 20 _____	7
	Regular checks _____	7
4	Disturbances in comfort _____	9
	Troubleshooting _____	9
	Contact information _____	11

Important information

Installation data

Product	ERS 20
Serial number	
Installation date	
Installer	

S-Series

No.	Name	Fact. sett.	Set
7.1.4.1	Fan speed, exhaust air	75%	
7.1.4.2	Fan speed, supply air	60%	
7.2.11	Vent. heat exchanger (ERS) lowest extract air temp. bypass at excess temperature	5 °C 4 °C	

F-Series

No.	Name	Fact. sett.	Set
5.1.5	fan sp. exhaust air	75%	
5.1.6	fan sp. supply air	60%	
5.3.12	exhaust/supply air module lowest extract air temp. bypass at excess temperature	5 °C 4 °C	

Serial number must always be given

It is hereby certified that the installation has been carried out in accordance with the instructions in the Installer manual and applicable regulations.

Date _____

Signed _____

Safety information

This appliance can be used by children aged from 8 years and above and persons with reduced physical, sensory or mental capabilities or lack of experience and knowledge if they have been given supervision or instruction concerning use of the appliance in a safe way and understand the hazards involved. Children shall not play with the appliance. Cleaning and user maintenance shall not be made by children without supervision.

This is an original manual. It may not be translated without the approval of NIBE.

Rights to make any design or technical modifications are reserved.

©NIBE 2023.

SYMBOLS

Explanation of symbols that may be present in this manual.



NOTE

This symbol indicates danger to person or machine.



Caution

This symbol indicates important information about what you should observe when maintaining your installation.

Serial number

The serial number can be found at the top left.

Serial number

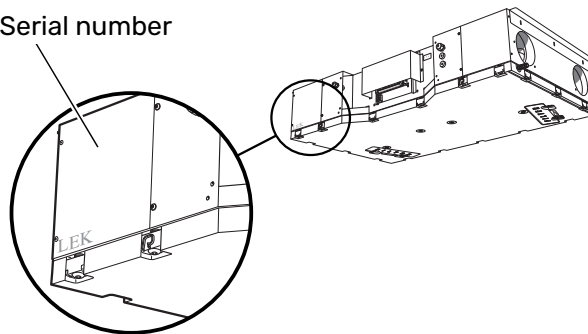

Caution

You need the product's serial number for servicing and support.

Compatible products

S-SERIES

- S1155
- S1255
- VVM S320
- VVM S325
- SMO S40

F-SERIES

- F1145
- F1155
- F1245
- F1255
- F1345
- F1355
- VVM 310
- VVM 320
- VVM 325
- VVM 500
- SMO 40

Function of the HRV unit

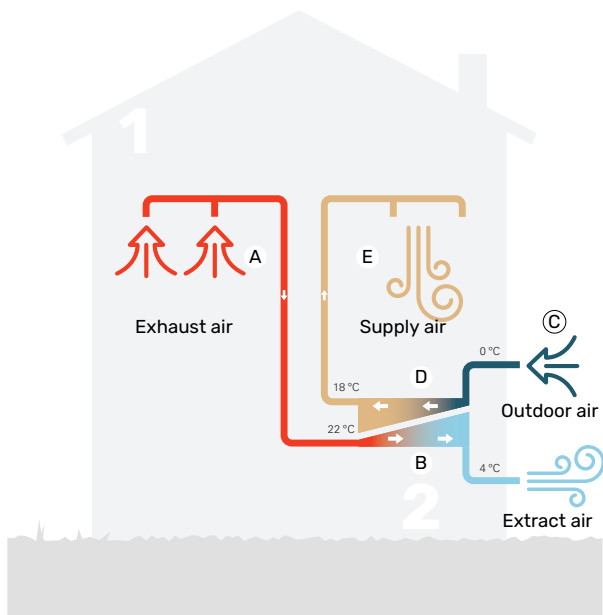

The temperatures are only examples and may vary between different installations and time of year.

An HRV unit is a ventilation heat exchanger that utilises the heat in the house's ventilation air to heat the incoming outdoor air. From the outgoing ventilation air (1), heating energy is recovered from the dwelling and transferred to the HRV unit. In the heat exchanger (2), the heat from the indoor air is transferred to the incoming outdoor air.

Ventilation air

- A** The hot air is transferred from the rooms to the HRV unit via the building's ventilation system using a fan.
- B** In the HRV unit, the air releases heat energy and the temperature drops significantly. The cold air is then blown out of the building.

Outdoor air

- C** The outdoor air is transferred to the HRV unit via the building's ventilation system.
- D** In the HRV unit, the air absorbs the heat energy and the temperature is raised.
- E** A fan blows the heated air into those rooms that have supply air inlets.

Maintenance of ERS 20

Regular checks

Your HRV unit requires minimal maintenance after commissioning. However, it is recommended that you check your installation regularly.

If something unusual occurs, messages about the malfunction, in the form of different alarm texts, appear in the main product display.



NOTE

Always switch off the power and wait until the fans have stopped before opening ERS 20.

CLEANING THE VENTILATION DEVICES

The building's ventilation devices should be cleaned regularly with, for example, a small brush to maintain the correct ventilation.

The device settings must not be changed.

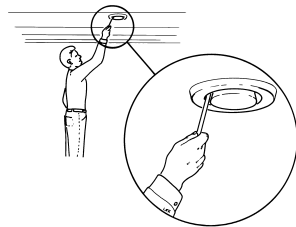

NOTE

If you take down more than one ventilation device for cleaning, do not mix them up.

REPLACING THE AIR FILTER

The filters in ERS 20 are of a type that should not be cleaned; they have to be replaced instead. These must be replaced regularly, although how often depends of factors such as the amount of particles in the ventilation air. Test to find out what is most appropriate for your installation.



Caution

The efficiency of the installation can be reduced by a dirty air filter.

In the main product's display, you will receive a reminder to check the filters. The factory setting for the reminder is every three months, although the countdown begins again if the power to the main product is interrupted.

1. Switch off the main product.
2. Release the air filters by turning the knobs on the covers a quarter of a turn.
3. Remove the covers.
4. Remove the filters.

5. Check the condition of the filters and replace if needed.
6. Carry out assembly in reverse order.

Even if the filters look clean, dirt collects in them and this affects the efficiency of the filters. For this reason, replace them after approx. 1 years. New filters can be ordered via a dealer for NIBE.

Exhaust air filter: Coarse 65%

Supply air filter: ePM1 55%

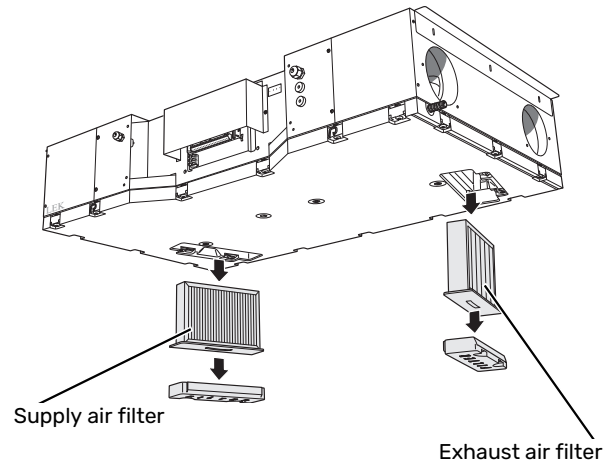

CHECK THE WATER LOCK FOR CONDENSATION WATER

The water seal must be checked at least once a year, ideally in the autumn.

The water seal is located outside ERS 20. Contact your installer if you are unsure of where to find it.

No condensation water is generated in the HRV unit during the warm period of the year and the water seal will dry out.

During the colder parts of the year, ERS 20 can produce several litres of condensation water every day. If the condensation outlet is not working, this may cause water damage inside the home.

The water seal must not dry out during this part of the year, because air will be drawn into the HRV unit due to the negative pressure in the unit, which will then prevent the condensation water from running out.

1. Check that the condensation drain and the water seal are not clogged with dirt.
2. Pour approx. one litre of water into the water seal.
3. Check that the water runs through unobstructed.

CLEANING THE HEAT EXCHANGER

Check the heat exchanger every other year and clean if necessary. Avoid contact with the fins.



Caution

Do not damage the fins. If you are unsure, contact your installer for help with cleaning.

1. Remove the four screws holding the heat exchanger.
2. Remove the trim and the metal rail.
3. Carefully lift out the heat exchanger.
4. Clean the heat exchanger carefully, e.g. with a vacuum cleaner. If necessary, you can use warm water and mild soap.

Carry out assembly in reverse order.



NOTE

It is important that the metal rail is positioned on the same side, so that the heat exchanger is angled in the same direction as previously when reinstalling.

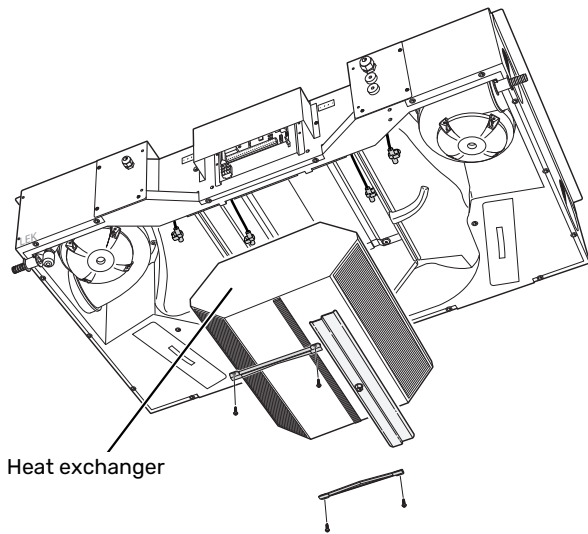

Heat exchanger

Disturbances in comfort

In most cases, the main product notes a malfunction (a malfunction can lead to disturbance in comfort) and indicates this with alarms and shows action instructions in the display.

Troubleshooting

If the operational interference is not shown in the display the following tips can be used:

BASIC ACTIONS

Start by checking the following items:

- That the main product is running and that the supply cable to ERS 20 is connected.
- Group and main fuses of the accommodation.
- The property's earth circuit breaker.

LOW OR A LACK OF VENTILATION

- Level monitor tripped.
 - Checking the condensation water drain and water seal.
- The exhaust air filter and/or the supply air filter is clogged.
 - Replace the filters.
- The ventilation is not adjusted.
 - Order ventilation adjustment.
- Closed, too much choke or blocked ventilation device.
 - Check and clean ventilation valves (see page 7).
- Fan speed in reduced mode.
 - S-series: Enter the main product's menu 1.2.1 and select "Normal".
 - F-series: Enter the main product's menu 1.2 and select "normal".
- External switch for changing the fan speed activated.
 - Check any external switches.
- Fan running slow because of low incoming outdoor air temperature.
 - Contact the installer in the event of recurring problems.

HIGH OR DISTRACTING VENTILATION

- The exhaust air filter and/or the supply air filter is clogged.
 - Replace the filters.
- The ventilation is not adjusted.
 - Order ventilation adjustment.
- Closed, too much choke or blocked ventilation device.
 - Check and clean ventilation valves (see page 7).
- Fan speed in forced mode.

- S-series: Enter the main product's menu 1.2.1 and select "Normal".
- F-series: Enter the main product's menu 1.2 and select "normal".
- External switch for changing the fan speed activated.
 - Check any external switches.
- Silencers not correctly installed.
 - Contact your installer!

Contact information

AUSTRIA

KNV Energietechnik GmbH
Gahberggasse 11, 4861 Schörfling
Tel: +43 (0)7662 8963-0
mail@knv.at
knv.at

FINLAND

NIBE Energy Systems Oy
Juurakkotie 3, 01510 Vantaa
Tel: +358 (0)9 274 6970
info@nibe.fi
nibe.fi

GREAT BRITAIN

NIBE Energy Systems Ltd
3C Broom Business Park,
Bridge Way, S41 9QG Chesterfield
Tel: +44 (0)330 311 2201
info@nibe.co.uk
nibe.co.uk

POLAND

NIBE-BIAWAR Sp. z o.o.
Al. Jana Pawla II 57, 15-703 Bialystok
Tel: +48 (0)85 66 28 490
biawar.com.pl

CZECH REPUBLIC

Družstevní závody Dražice - strojírna
s.r.o.
Dražice 69, 29471 Benátky n. Jiz.
Tel: +420 326 373 801
nibe@nibe.cz
nibe.cz

FRANCE

NIBE Energy Systems France SAS
Zone industrielle RD 28
Rue du Pou du Ciel, 01600 Reyrieux
Tél: 04 74 00 92 92
info@nibe.fr
nibe.fr

NETHERLANDS

NIBE Energietechnik B.V.
Energieweg 31, 4906 CG Oosterhout
Tel: +31 (0)168 47 77 22
info@nibenl.nl
nibenl.nl

SWEDEN

NIBE Energy Systems
Box 14
Hannabadsvägen 5, 285 21 Markaryd
Tel: +46 (0)433-27 30 00
info@nibe.se
nibe.se

DENMARK

Vølund Varmeteknik A/S
Industrivej Nord 7B, 7400 Herning
Tel: +45 97 17 20 33
info@volundvt.dk
volundvt.dk

GERMANY

NIBE Systemtechnik GmbH
Am Reiherpfahl 3, 29223 Celle
Tel: +49 (0)5141 75 46 -0
info@nibe.de
nibe.de

NORWAY

ABK-Qviller AS
Brobekkeveien 80, 0582 Oslo
Tel: (+47) 23 17 05 20
post@abkqviller.no
nibe.no

SWITZERLAND

NIBE Wärmetechnik c/o ait Schweiz AG
Industriepark, CH-6246 Altishofen
Tel. +41 (0)58 252 21 00
info@nibe.ch
nibe.ch

For countries not mentioned in this list, contact NIBE Sweden or check nibe.eu for more information.

NIBE Energy Systems
Hannabadsvägen 5
Box 14
SE-285 21 Markaryd
info@nibe.se
nibe.eu

UHB EN 2245-1 731461

This is a publication from NIBE Energy Systems. All product illustrations, facts and data are based on the available information at the time of the publication's approval.

NIBE Energy Systems makes reservations for any factual or printing errors in this publication.

©2023 NIBE ENERGY SYSTEMS

