



Indoor module

NIBE VVM 225

The NIBE VVM 225 is designed for combination with NIBE air/water heat pump to create a highly-efficient climate system for your home.

The NIBE VVM 225 has a smart, user-friendly control system which provides efficient heating and hot water with high performance. The NIBE VVM 225 is ready for installation since the water heater, electric additional heat, self-regulating circulation pump, filling valve, pressure gauge, safety valve and expansion vessel are included.

Thanks to intelligent technology, the product gives you control over your energy consumption and will be a key part of your connected home. The efficient control system automatically adjusts the indoor climate for high comfort, and you do nature a favour at the same time.



- **Combine NIBE VVM 225 with a NIBE air/water heat pump for an energy- efficient climate system.**
- **Energy-saving smart technology with user-friendly control.**
- **Part of your smart home – Control your comfort online using NIBE Uplink.**

This is how NIBE VVM 225 works

Installation method



VVM 225 consists of water heater with charge coil, expansion vessel, safety valves, filler valve, immersion heater, circulation pump and control system.

VVM 225 is directly adapted for connection and communication with NIBE air/water heat pump, which together constitute a complete heating installation.

The air/water heat pump absorbs energy from the outdoor air and transforms this into heat energy for the indoor air. The indoor module distributes heat and domestic hot water.

NIBE air/water heat pump covers most of the heating and hot water requirement down to the heat pump's stop temperature. If the outdoor temperature drops to a level below the heat pump's stop temperature, all heating is then provided using NIBE VVM 225.

VVM 225 is easy to install. All pipe connections are easily accessible. This is especially useful for the replacement market.

A system with VVM 225 and NIBE's compatible air/water heat pumps allows a complete, energy-saving installation. VVM 225 can be supplemented with several different accessories.

OUTDOOR MODULES

Compatible air/water heat pumps

F2050

F2050-6
Part no. 064 328

F2050-10
Part no. 064 318

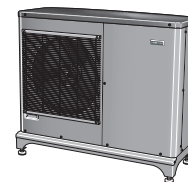

S2125

**S2125-8
1x230V**
Part no. 064 220

**S2125-8
3x400V**
Part no. 064 219



**S2125-12
1x230V¹**
Part no. 064 218

**S2125-12
3x400V¹**
Part no. 064 217

¹ When combined with VVM 225, the system must be supplemented with NIBE UKV.

NIBE SPLIT HBS 20

AMS 20-6
Part no. 064 235

HBS 20-6
Part no. 067 668

AMS 20-10
Part no. 064 319

HBS 20-10
Part no. 067 819

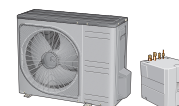

Design

VVM 225 is fitted with intelligent control. This makes for easy operation while always enabling the indoor module to be used as efficiently as possible. The circulation pump is controlled for optimum operation. Current temperatures and set values can easily be shown on the display.

The insulation is made of moulded Neopor, which provides excellent heat insulation.

The outer casing is made of white, powder-coated, steel plate.

Principle of operation

Principle of operation with air/water heat pump, hot water and a heating system.

The heat is retrieved from the outdoor air by an air/water heat pump, where the refrigerant, which circulates in a closed system, transfers the heat from the heat source (the outdoor air) to the indoor module VVM 225.

ENAMEL

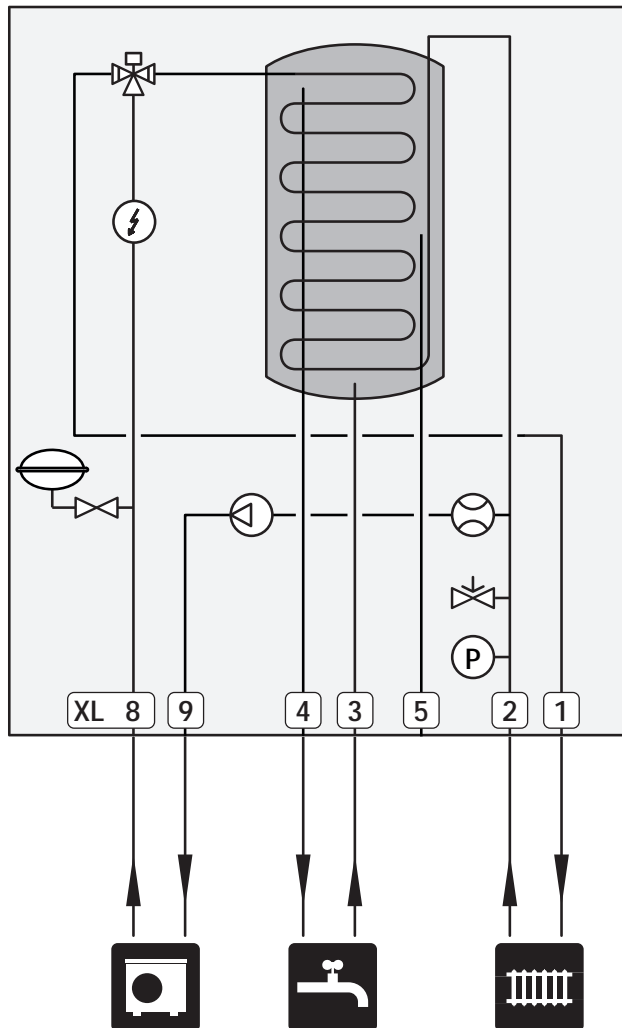

STAINLESS STEEL

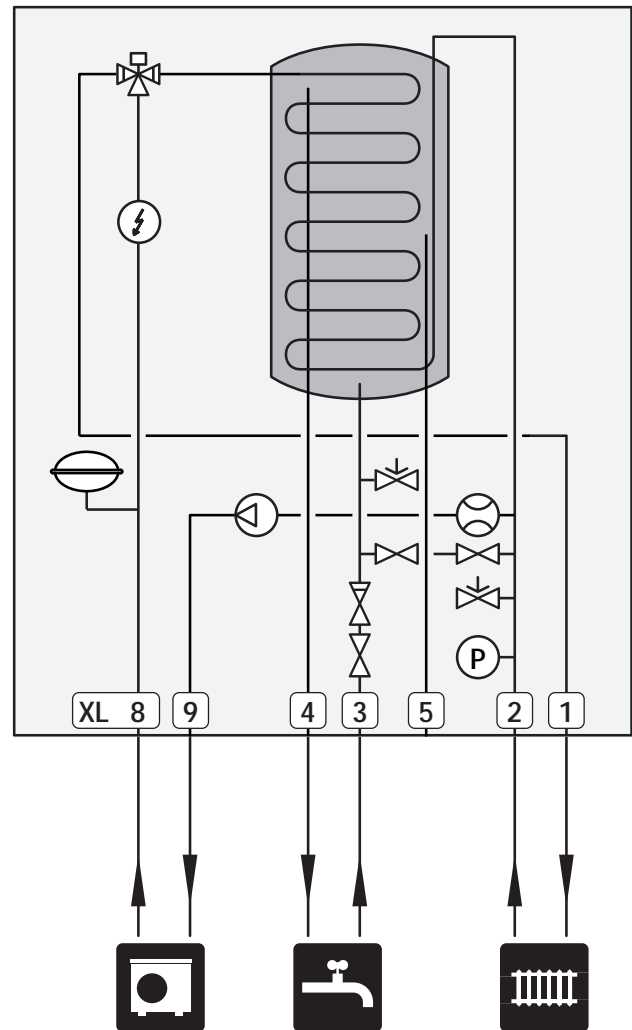

- | | |
|-----|--|
| XL1 | Connection, heating medium flow line |
| XL2 | Connection, heating medium return line |
| XL3 | Connection, cold water |
| XL4 | Connection, hot water |
| XL5 | Connection, hot water circulation (does not apply to copper) |
| XL8 | Connection, docking from heat pump |
| XL9 | Connection, docking to heat pump |

Good to know about VVM 225

Transport and storage

VVM 225 should be transported and stored vertically in a dry place.

However, the VVM 225 can be carefully laid on its back when being moved into a building.

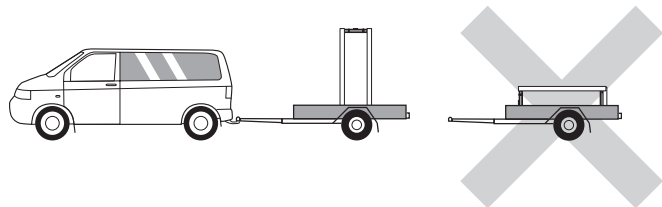

Supplied components

Local differences in the enclosed kit may occur. See relevant installer manual for more information.

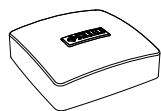

Outside sensor

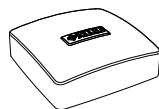

Room sensor



Current sensor*

*Only to 3X400V

Installation and positioning

- Position VVM 225 on a solid foundation indoors that withstands water and the weight of the product.
- The space where VVM 225 is located must be frost-free.
- Because water can emerge from the safety valve, the area where VVM 225 is located must be provided with floor drainage.

INSTALLATION AREA

Leave a free space of 800 mm in front of the product. All service on VVM 225 can be carried out from the front.

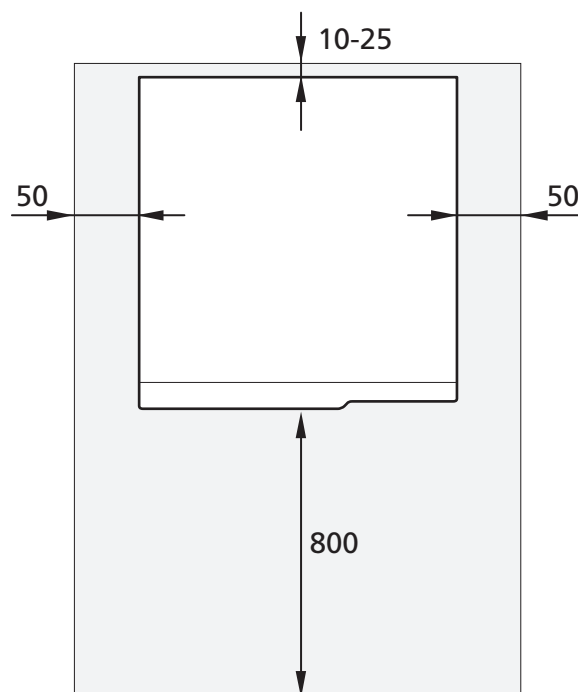

Leave 10 – 25 mm free space between VVM 225 and the wall behind for routing cables and pipes.

Installation

Pipe installation

The heating medium side and the domestic hot water side must be fitted with the necessary safety equipment in accordance with the applicable regulations.

WASTE WATER

Water may drip from the safety valve. A factory-fitted overflow pipe runs from the safety valve to an overflow cup. An overflow pipe has to be routed from the overflow cup to a suitable drain. The overflow pipe must be inclined along its entire length to prevent pockets where water can accumulate, and must be frost-proof.

NIBE DIM

The system requires the radiator circuit to be designed for a low temperature heating medium. At the lowest dimensioned outdoor temperature (DOT), the highest recommended temperatures are 55 °C on the supply line and 45 °C on the return line. VVM 225 can cope with up to 70 °C. For correct dimensioning of the heat pump, NIBE dimensioning program NIBE DIM is recommended.

HEATING MEDIUM

A climate system is a system that regulates indoor comfort with the help of the control system in VVM 225 and for example radiators, underfloor heating/cooling, fan convectors etc.

- When connecting to a system with thermostats on all radiators (or underfloor heating coils), either a bypass valve must be fitted or some of the thermostats must be removed to ensure there is sufficient flow.

COLD AND HOT WATER

A mixer valve must also be installed, if the factory setting for hot water is changed. National regulations must be observed.

Ensure that incoming water is clean. When using a private well, it may be necessary to supplement with an extra water filter.

For more information see nibe.eu.

INSTALLATION ALTERNATIVE

VVM 225 can be connected in several ways. The necessary safety equipment must be installed in accordance with current regulations for all installation options.

See nibe.eu for more detailed installation options.

PUMP CAPACITY DIAGRAM

Available pressure circulation pump, GP1

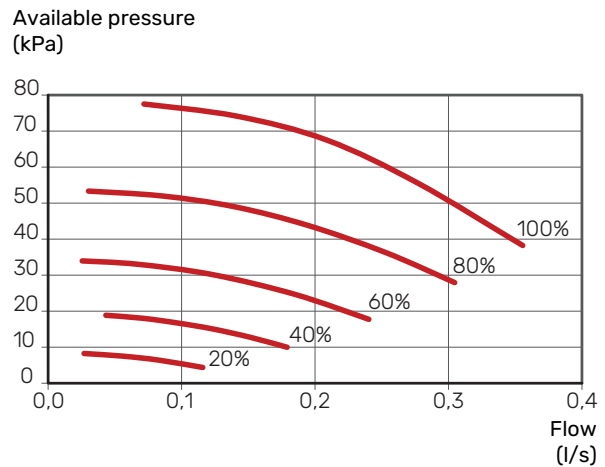

PIPE DIMENSIONS AND SYSTEM FLOWS

Minimum system flows

The pipe dimension should not be less than the recommended pipe diameter according to the table. However, each system must be dimensioned individually to manage the recommended system flows.

The installation must be dimensioned to manage at least the minimum defrosting flow at 100% pump operation, see table.

Air/water heat pump	Minimum flow during defrosting (100% pump speed (l/s))	Minimum recommended pipe dimension (DN)	Minimum recommended pipe dimension (mm)
AMS 20-6	0.19	20	22
AMS 20-10			

Air/water heat pump	Minimum flow during defrosting (100% pump speed (l/s))	Minimum recommended pipe dimension (DN)	Minimum recommended pipe dimension (mm)
F2050-6	0.19	20	22
F2050-10			

Air/water heat pump	Minimum flow during defrosting (100% pump speed (l/s))	Minimum recommended pipe dimension (DN)	Minimum recommended pipe dimension (mm)
S2125-8 (1x230V)	0.32	25	28
S2125-8 (3x400V)			
S2125-12 (1x230V)			
S2125-12 (3x400V)			

An undersized system can result in damage to the product and lead to malfunctions.

Electrical installation

ELECTRICAL CONNECTIONS

Electrical installation and service must be carried out under the supervision of a qualified electrician. Cut the current with the circuit breaker before carrying out any servicing. Electrical installation and wiring must be carried out in accordance with the stipulations in force.

General

All electrical equipment, except the outdoor sensors, room sensors and the current sensors are ready connected at the factory.

- Disconnect the indoor module before insulation testing the house wiring.
- If the building is equipped with an earth-fault breaker, VVM 225 should be equipped with a separate one.
- The electrical wiring diagram for the indoor module can be found in the Installer manual.
- A screened three-core cable is used as the communication cable.
- Communication and sensor cables to external connections must not be laid close to high current cables.
- The minimum area of communication and sensor cables to external connections must be 0.5 mm² up to 50, for example EKKX or LiYY or equivalent.

Power connection

VVM 225 must be installed with a disconnection option on the supply cable. Minimum cable area must be sized according to the fuse rating used. The enclosed cable (length approx 2 m) for incoming electricity is connected to terminal block X1 on the immersion heater board. All installations must be carried out in accordance with current norms and directives. The connection cable can be found on the reverse of VVM 225.

Miniature circuit-breaker

The indoor module and a large proportion of its internal components are internally fused by a miniature circuit breaker.

Temperature limiter

The temperature limiter cuts the power supply to the electric additional heat, if the temperature rises to between 90 and 100 °C and it is reset manually.

SETTINGS

Electric additional heat – maximum output

The immersion heater is adjustable up to a maximum of 9 kW. At 1 x 230 V, the immersion heater is adjustable up to a maximum of 7 kW.

The immersion heater output is divided into seven steps, according to the table in the Installer Manual.

Emergency mode

When the indoor module's switch is set to emergency mode, only the most essential functions are activated.

- The hot water capacity is reduced.
- The load monitor is not connected.
- Fixed temperature in the supply line.

Maintenance of VVM 225

Regular checks

A minimum level of maintenance is required. Only safety valves require checking. All essential components can be accessed from the front. This facilitates service and maintenance.

If anything abnormal occurs, messages about the malfunction appear in the display in the form of various alarm texts.

Functions

Control, general

The indoor temperature depends on several different factors. Sunlight and heat emissions from people and household machines are normally sufficient to keep the house warm during the warm seasons. When it gets colder outside, the climate system needs to help heat the house. The colder it is outside, the warmer radiators and underfloor heating systems have to be.

Control of the heat production is performed based on the "floating condensing" principle, which means that the temperature level needed for heating at a specific outdoor temperature is produced based on collected values from the outdoor and supply temperature sensors. The room sensor can also be used to compensate the deviation in room temperature.

Heat production



The supply of heat to the house is regulated in accordance with the heating curve selected setting. After adjustment, the correct amount of heat for the current outdoor temperature is supplied. The

supply temperature will oscillate around the theoretically desired value.

OWN CURVE

VVM 225 has pre-programmed non-linear heating curves. It is also possible to create your own defined curve. This is an individual linear curve with a number of break points. You select break points and the associated temperatures.

Hot water production



Hot water charging starts when the temperature has fallen to the set start temperature. Hot water charging stops when the hot water temperature at the hot water sensor has been reached.

For temporary higher hot water demand, there is a function that allows the temperature to be raised temporarily for up to 12 hours or by a one time increase (can be selected in the menu system).

With the Smart Control function activated, VVM 225 learns how much hot water is used and when. The Smart Control function memorises the previous week's hot water consumption and adapts the hot water temperature for the coming week to ensure minimal energy consumption.

It is also possible to set VVM 225 in holiday mode, which means that the lowest possible temperature is achieved without the risk of freezing.

Additional heat only

ADDITIONAL HEAT ONLY



VVM 225 can be used with additional heat only (electric boiler) to produce heating and hot water, for example before the outdoor module is installed.

Alarm indications



The status lamp lights red in the event of an alarm and the display shows detailed information depending on the fault. An alarm log is created with each alarm containing a number of temperatures, times and operating status.

The display



VVM 225 is controlled using a clear and easy to use display.

Instructions, settings and operational information are shown on the display. You can easily navigate between the different menus and options to set the comfort or obtain the information you require.

The display unit is equipped with a USB socket that can be used to update the software and save logged information in VVM 225.

Visit nibeuplink.com and click the "Software" tab to download the latest software for your installation.

NIBE Uplink



Using the Internet and NIBE Uplink, you can obtain a quick overview and the present status of the installation and the heating in your home. You can obtain a good overall view, allowing you to monitor and control the heating and hot water comfort effectively. If the system is affected by a malfunction, you receive an alert via e-mail that allows you to react quickly.

NIBE Uplink also gives you the opportunity to control the comfort in your home easily, no matter where you are.

RANGE OF SERVICES

You have access to different levels of service via NIBE Uplink. A basic level that is free and a premium level where you can select different extended service functions for a fixed annual subscription fee (the subscription fee varies depending on the selected functions).

NIBE Uplink also available as an app from App Store and Google Play.

INSTALLATION AND ASSOCIATED EQUIPMENT REQUIREMENTS

NIBE Uplink needs the following in order to communicate with your VVM 225:

- network cable
- Internet connection to which VVM 225 can be connected
- web browser with JavaScript activated
- account on nibeuplink.com

We recommend our mobile app for NIBE Uplink.

For more information, visit nibeuplink.com.

NIBE SMART PRICE ADAPTION™



Smart Price Adaption is not available in all countries. Contact your NIBE dealer for more information.

Smart Price Adaption adjusts the system's consumption according to the time of day when electricity prices are lowest. This allows for savings, provided that an hourly rate subscription has been signed with the electricity supplier.

The function is based on hourly rates for the coming day being downloaded via NIBE Uplink. To use the function, an Internet connection and account on NIBE Uplink are necessary.

SMART HOME

When you have a smart home system that can communicate with NIBE Uplink, you can control the installation via an app by activating the "smart home" function.

By allowing connected units to communicate with NIBE Uplink, your heating system becomes a natural part of your homesmart home and gives you the opportunity to optimise the operation.

Remember that the "smart home" function requires NIBE Uplink in order to work.

NIBE SMART ENERGY SOURCE™



Smart Energy Source™ prioritises how / to what extent each docked energy source will be used.

Here you can choose if the system is to use the energy source that is cheapest at the time. You can also choose if the system is to use the energy source that is most carbon neutral at the time.

Technical data

Dimensions

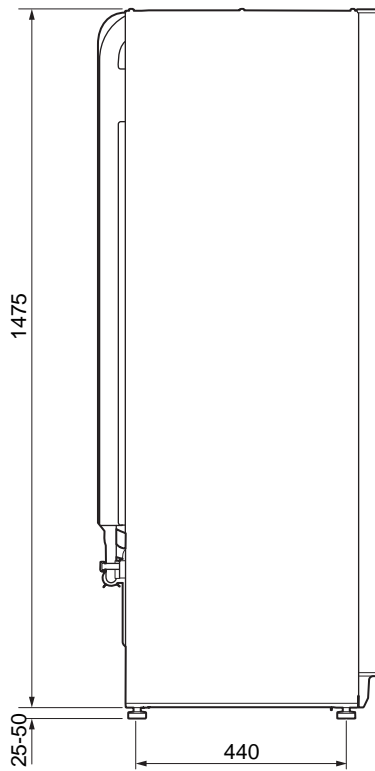
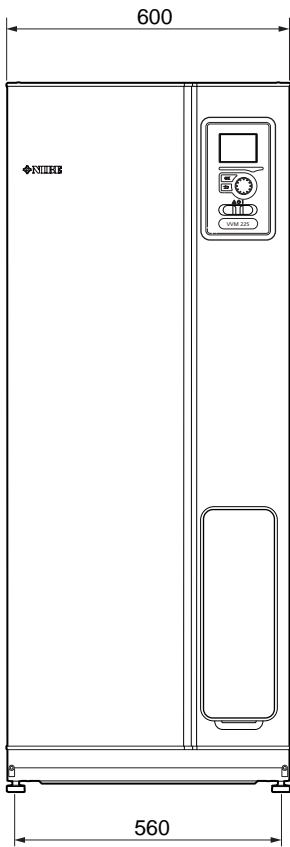
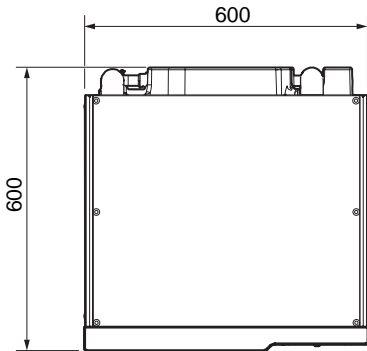

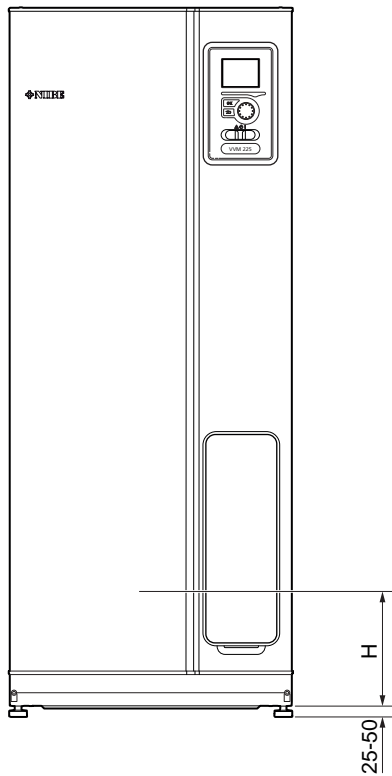
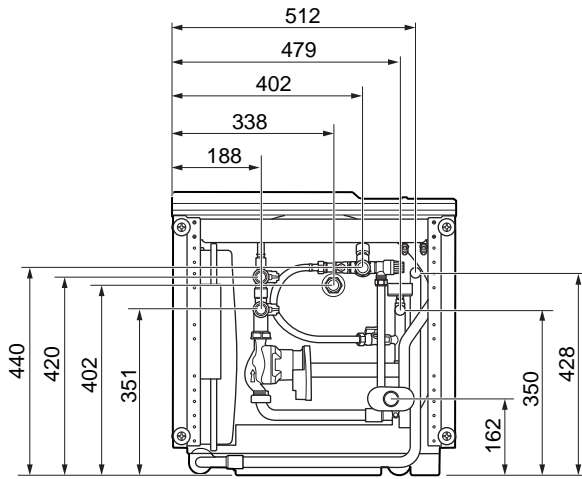

Connection		H	X	Y
XL1 Heating medium supply line Ø	mm	200	512	428
XL2 Heating medium return line Ø	mm	200	479	350
XL3 Cold water Ø	mm	250	402	440
XL4 Hot water Ø	mm	260	338	402
XL5 Hot water circulation Ø	mm	280	300	402
XL8 Connection, docking from heat pump Ø	mm	85	188	420
XL9 Connection, docking to heat pump Ø	mm	85	188	351
WM1 Drip tray	mm	145	460	162

Technical specifications

3 x 400V		
Electrical data		
Additional power	kW	9
Rated voltage		400 V 3N-50 Hz
Max operating current	A	16
Fuse	A	16
Output, GP1	W	2 - 75
Enclosure class		IPX1B
Heating medium circuit		
Energy class, GP1		low energy
Max system pressure heating medium	MPa	0.3 (3 bar)
Max HM temp	°C	70
Pipe connections		
Heating medium	mm	Ø22
Hot water connection	mm	Ø22
Cold water connection	mm	Ø22
Hot water circulation	mm	Ø15
Heat pump connections	mm	Ø22
Other, indoor module		
Volume water heater Stainless steel / Enamel	l	176 / 178
Volume coil Stainless steel / Enamel	l	7.7 / 4.7
Max. permitted pressure, water heater	MPa (bar)	1.0 (10 bar)
Cut-off pressure, water heater (does not apply to part no. 069 227)	MPa (bar)	1.0 (10 bar)
Max permitted pressure in indoor module	MPa (bar)	0.3 (3 bar)
Cut-off pressure, indoor module	MPa (bar)	0.25 (2.5 bar)
Capacity, hot water heating according to EN16147		
Tap volume 40°C at Economy comfort	l	130
Tap volume 40 °C during Normal comfort	l	176
Tap volume 40 °C during Lux comfort	l	199
Dimensions and weight		
Width	mm	600
Depth	mm	600
Height (without base)	mm	1,475
Height (with base)	mm	1,500 - 1,525
Required ceiling height	mm	1,550
Weight (excl. packaging and without water) Stainless steel / Enamel	kg	98 / 137
Part no.		
Part number - VVM 225 E EM 3x400V		069 227
Part number - VVM 225 R EM 3x400V		069 229

3 x 230 V		
Electrical data		
Additional power	kW	9
Rated voltage		230V 3N-50Hz
Max operating current	A	27.5
Fuse	A	32
Output, GP1	W	2 – 75
Enclosure class		IPX1B
Heating medium circuit		
Energy class, GP1		low energy
Max system pressure heating medium	MPa	0.3 (3 bar)
Max HM temp	°C	70
Pipe connections		
Heating medium		Ø22
Hot water connection		Ø22
Cold water connection		Ø22
Hot water circulation		Ø15
Heat pump connections		Ø22
Other, indoor module		
Volume, hot water heater	l	176
Volume coil Stainless steel	l	7.7
Max. permitted pressure, water heater	MPa (bar)	1.0 (10 bar)
Cut-off pressure, hot water heater	MPa (bar)	1.0 (10 bar)
Max permitted pressure in indoor module	MPa (bar)	0.3 (3 bar)
Cut-off pressure, indoor module	MPa (bar)	0.25 (2.5 bar)
Capacity, hot water heating according to EN16147		
Tap volume 40°C at Economy comfort	l	130
Tap volume 40 °C during Normal comfort	l	176
Tap volume 40 °C during Lux comfort	l	199
Dimensions and weight		
Width	mm	600
Depth	mm	600
Height (without base)	mm	1,475
Height (with base)	mm	1,500 – 1,525
Required ceiling height	mm	1,550
Weight (excl. packaging and without water)	kg	98
Part no.		
Part number Stainless steel – VVM 225 R EM 3x230V		069 230

1 x 230 V		
Electrical data		
Additional power	kW	7
Rated voltage		230V-50Hz
Max operating current	A	32
Fuse	A	32
Output, GP1	W	2 – 75
Enclosure class		IPX1B
Heating medium circuit		
Energy class, GP1		low energy
Max system pressure heating medium	MPa	0.3 (3 bar)
Max HM temp	°C	70
Pipe connections		
Heating medium		Ø22
Hot water connection		Ø22
Cold water connection		Ø22
Hot water circulation		Ø15
Heat pump connections		Ø22

Other, indoor module		
Volume, hot water heater	l	176
Volume coil Stainless steel	l	7.7
Max. permitted pressure, water heater	MPa (bar)	1.0 (10 bar)
Cut-off pressure, hot water heater	MPa (bar)	1.0 (10 bar)
Max permitted pressure in indoor module	MPa (bar)	0.3 (3 bar)
Cut-off pressure, indoor module	MPa (bar)	0.25 (2.5 bar)
Capacity, hot water heating according to EN16147		
Tap volume 40°C at Economy comfort	l	130
Tap volume 40 °C during Normal comfort	l	176
Tap volume 40 °C during Lux comfort	l	199
Dimensions and weight		
Width	mm	600
Depth	mm	600
Height (without base)	mm	1,475
Height (with base)	mm	1,500 – 1,525
Required ceiling height	mm	1,550
Weight (excl. packaging and without water)	kg	98
Part no.		
Part number Stainless steel – VVM 225 R EM 1x230V		069 231

Accessories

Detailed information about the accessories and complete accessories list available at nibe.eu.

Not all accessories are available on all markets.

Active cooling ACS 310¹

ACS 310 is an accessory that enables VVM 225 to control the production of cooling.

Part no. 067 248

¹ The accessory requires that a NIBE air/water heat pump is installed.

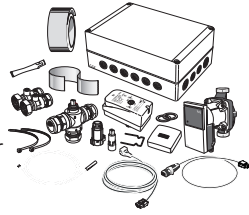

Energy measurement kit EMK 300¹

This accessory is installed externally and used to measure the amount of energy that is supplied for the pool/hot water/heating/cooling for the house.

Part no. 067 314

¹ The accessory requires that a NIBE air/water heat pump is installed.

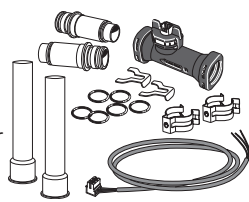

Extra shunt group ECS

This accessory is used when VVM 225 is installed in houses with two or more different heating systems that require different supply temperatures.

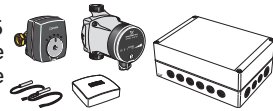

ECS 40 (Max 80 m²)

Part no 067 287

ECS 41 (approx. 80-250 m²)

Part no 067 288

Exhaust air module F135¹

F135 is an exhaust air module specially designed to combine recovery of mechanical exhaust air with an air/water heat pump. Indoor module/control module controls F135.

Part no. 066 075

¹ The accessory requires that a NIBE air/water heat pump is installed.



HRV unit ERS

This accessory is used to supply the accommodation with energy that has been recovered from the ventilation air. The unit ventilates the house and heats the supply air as necessary.



ERS S10-400¹

Part no. 066 163

ERS 20-250¹

Part no. 066 068

¹ A preheater may be required.

Base extension EF 45

This accessory is used to create a larger connection area under VVM 225.

Part no. 067 152

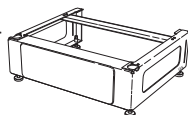

Communication module for solar electricity EME 20

EME 20 is used to enable communication and control between inverters for solar cells from NIBE and VVM 225.

Part no. 057 188

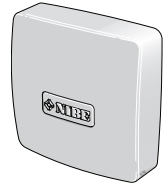

Pool heating POOL 310¹

POOL 310 is an accessory that enables pool heating with VVM 225.

Part no. 067 247

¹ The accessory requires that a NIBE air/water heat pump is installed.

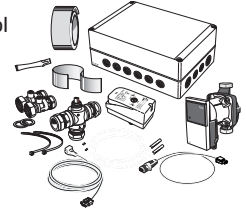

Solar package NIBE PV

NIBE PV is a modular system comprising solar panels, assembly parts and inverters, which is used to produce your own electricity.



Top cabinet TOC 30

Top cabinet, which conceals any pipes/ventilation ducts.

Height 245 mm

Part no. 067 517

Height 345 mm

Part no. 067 518

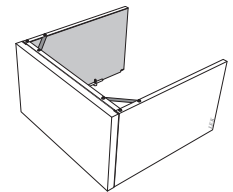

Height

385-635 mm

Part no. 067 519



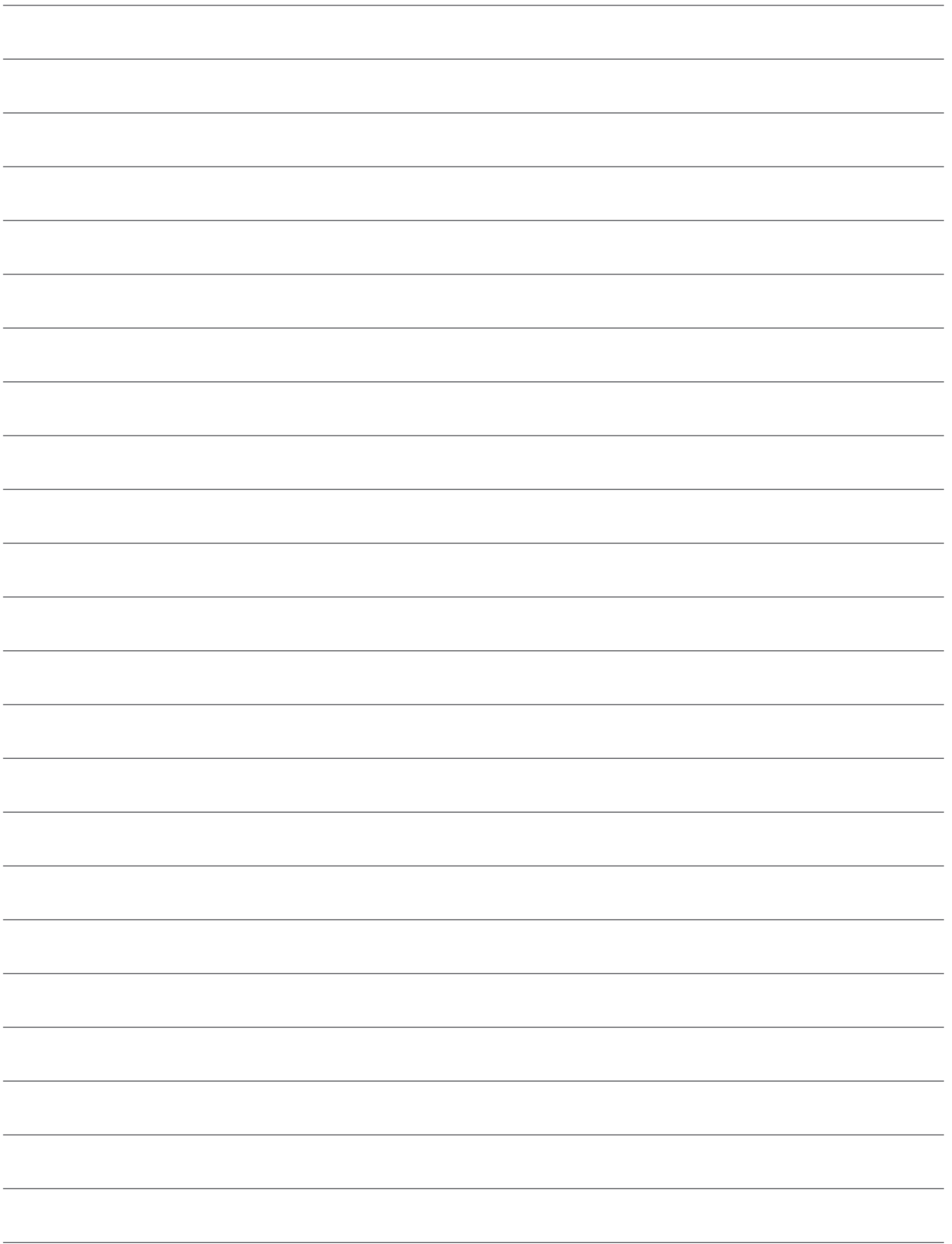

Sustainable energy solutions since 1952

NIBE has been manufacturing energy-efficient and sustainable climate solutions for your home for 70 years. It all began in Markaryd, in the southern Swedish province of Småland, and we recognise our Nordic heritage by utilising the power of nature. We combine renewable energy with smart technology to offer efficient solutions, allowing us to work together to create a more sustainable future.

Regardless of whether it is a chilly winter's day or a warm afternoon in the summer sun, we need a balanced indoor climate that allows us to enjoy a comfortable life, whatever the weather. Our extensive range of products supply your home with cooling, heating, ventilation and hot water, making it possible for you to create a pleasant indoor climate with little impact on the environment.

NIBE Energy Systems
Box 14, SE-285 21 Markaryd
nibe.eu



This product sheet is a publication from NIBE Energy Systems. All product illustrations, facts and data are based on current information at the time of the publication's approval. NIBE Energy Systems makes reservations for any factual or printing errors in this product sheet.