

USER'S MANUAL

DVC 10-50
DVC 10-50L
DVC 10-50W
DVC 10-50WL



Heat recovery single-room
reversible ventilator

CONTENTS

Safety requirements.....2
 Purpose.....4
 Delivery set.....4
 Designation key.....4
 Technical data.....5
 Design and functioning6
 Mounting and set-up.....8
 Connection to power supply and control11
 Maintenance.....28
 Troubleshooting.....30
 Storage and transportation regulations30
 Manufacturer’s warranty31
 Acceptance certificate32
 Seller information.....32
 Installation certificate.....32
 Warranty card.....32

The user’s manual consisting of the technical details, operating instructions and technical specification applies to the installation and mounting of the single-room reversible ventilator with energy regeneration NIBE DVC 10 (hereinafter «the unit» as mentioned in the «Safety Requirements» and «Manufacturer’s Warranty» sections as well as in warnings and information blocks).

SAFETY REQUIREMENTS

Read the user’s manual carefully prior to installing and operating the unit.

Fulfil the user’s manual requirements as well as the provisions of all the applicable local and national construction, electrical and technical norms and standards.



The warnings contained in the user’s manual must be considered most seriously since they contain vital personal safety information.

Failure to follow the rules and safety precautions noted in this user’s manual may result in an injury or unit damage.

After a careful reading of the manual, keep it for the entire service life of the unit.

While transferring the unit control the User’s manual must be turned over to the receiving operator.

Symbol legend:

	WARNING!
	DO NOT!

UNIT MOUNTING AND OPERATION SAFETY PRECAUTIONS



- Disconnect the unit from power mains prior to any installation operations.



- Unpack the unit with care.



- Do not lay the power cable of the unit in close proximity to heating equipment.



- While installing the unit follow the safety regulations specific to the use of electric tools.

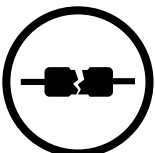

- Do not use damaged equipment or cables when connecting the unit to power mains.

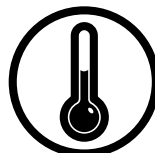

- Do not operate the unit outside the temperature range stated in the user's manual.
- Do not operate the unit in aggressive or explosive environments.



- Do not touch the unit controls with wet hands.
- Do not carry out the installation and maintenance operations with wet hands.



- Do not wash the unit with water.
- Protect the electric parts of the unit against ingress of water.

UNIT MOUNTING AND OPERATION SAFETY PRECAUTIONS



- Do not allow children to operate the unit.



- Disconnect the unit from power mains prior to any technical maintenance.



- Do not store any explosive or highly flammable substances in close proximity to the unit.



- When the unit generates unusual sounds, odour or emits smoke disconnect it from power supply and contact the Seller.

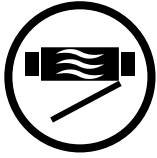

- Do not open the unit during operation.



- Do not direct the air flow produced by the unit towards open flame or ignition sources.



- Do not block the air duct when the unit is switched on.



- In case of continuous operation of the unit periodically check the security of mounting.

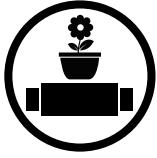

- Do not sit on the unit and avoid placing foreign objects on it.



- Use the unit only for its intended purpose.



**THE PRODUCT MUST BE COLLECTED SEPARATELY AT THE END OF SERVICE LIFE.
DO NOT DISPOSE OF AS UNSORTED MUNICIPAL WASTE.**

PURPOSE

The ventilator is designed to ensure continuous mechanical air exchange in houses, offices, hotels, cafes, conference halls and other utility and public spaces. The ventilator is equipped with a ceramic regenerator that enables supply of fresh filtered air heated by means of extract air heat energy regeneration.

The unit is designed for through-the-wall mounting.



THE UNIT MAY NOT BE OPERATED BY CHILDREN OR PERSONS WITH REDUCED PHYSICAL, MENTAL OR SENSORY CAPACITIES, OR LACKING THE APPROPRIATE TRAINING.

THE UNIT MUST BE INSTALLED AND CONNECTED ONLY BY PROPERLY QUALIFIED PERSONNEL AFTER THE APPROPRIATE BRIEFING.

THE CHOICE OF UNIT INSTALLATION LOCATION MUST PREVENT UNAUTHORIZED ACCESS BY UNATTENDED CHILDREN.

The unit is rated for continuous operation.

Transported air must not contain any flammable or explosive mixtures, evaporation of chemicals, sticky substances, fibrous materials, coarse dust, soot and oil particles or environments favourable for the formation of hazardous substances (toxic substances, dust, pathogenic germs).

DELIVERY SET

Name	Quantity
Indoor unit	1 item
Air duct	1 item
Sound absorbing material	1 item
Cartridge	1 item
Outer ventilation hood	1 item
Remote control	1 item
Cardboard template	1 item
Fastening kit	2 boxes
User's manual	1 item
Outer hood installation instruction	1 item
Packing box	1 item

DESIGNATION KEY

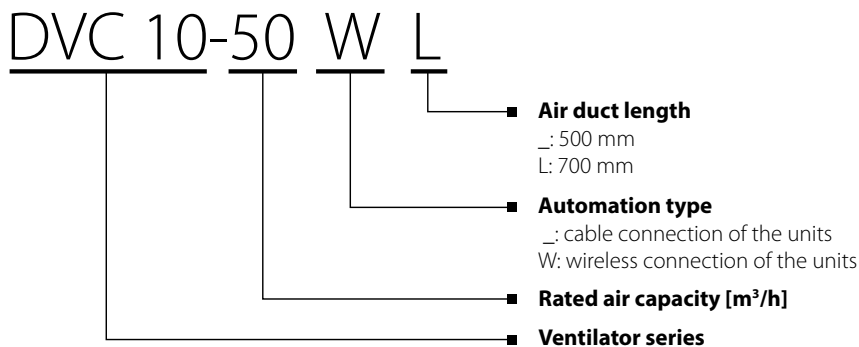

TECHNICAL DATA

The unit is rated for indoor application with the ambient temperature ranging from -30 °C up to +50 °C and relative humidity up to 97 %.
 The unit is rated as a class II electric appliance.
 Ingress Protection (IP) rating from solid objects and liquids IP24.
 The unit design is regularly improved, so some models may slightly differ from those ones described in this manual.

TECHNICAL DATA

Speed	DVC 10-50 (L)			DVC 10-50W (L)		
	I	II	III	I	II	III
Supply voltage, 50-60 Hz [V]	1~ 100 - 240			1~ 100 - 240		
Power consumption [W]	3.61	4.15	5.2	4.45	5.08	7.06
Current consumption [A]	0.025	0.030	0.039	0.035	0.040	0.059
Air capacity [m³/h]	15	30	50	15	30	50
Filters	G3 (MERV 7); F8 (MERV 13) option			G3 (MERV 7); F8 (MERV 13) option		
Transported air temperature [°C] (°F)	from -30 (-22) to 50 (122)					
Noise level, 1 m [dB(A)] (Sones)	20	27	30	20	27	30
Noise level, 3 m [dB(A)] (Sones)	11	18	21	11	18	21
Noise level attenuation [dB(A)] (Sones)	42			42		
Heat recovery efficiency [%]	97	90	82	97	90	82
Ingress Protection (IP)	IP24			IP24		

WI-FI TECHNICAL DATA (APPLICABLE FOR DVC 10-50W(L) ONLY)

Standard:	IEEE 802.11 b/g/n
Frequency band [GHz]	2.4
Transmission power [mW] (dBm)	100 (+20)
Network	DHCP
WLAN safety	WPA, WPA2

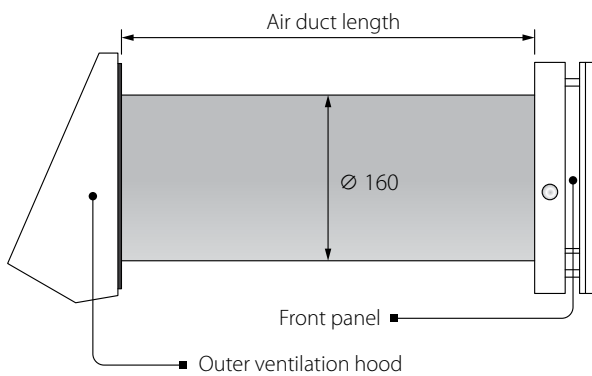

The air duct length depends on the unit model, refer the Designation Key.

Air duct length	
DVC 10-50 (W)	250-500
DVC 10-50 (W)L	250-700

The ventilation hood model depends on the unit model. The overall dimensions of the outer ventilation hood are stated in the mounting instruction for the outer hood.
 The overall dimensions of the front panel see below.

OVERALL DIMENSIONS OF THE INDOOR ASSEMBLY UNIT [MM]

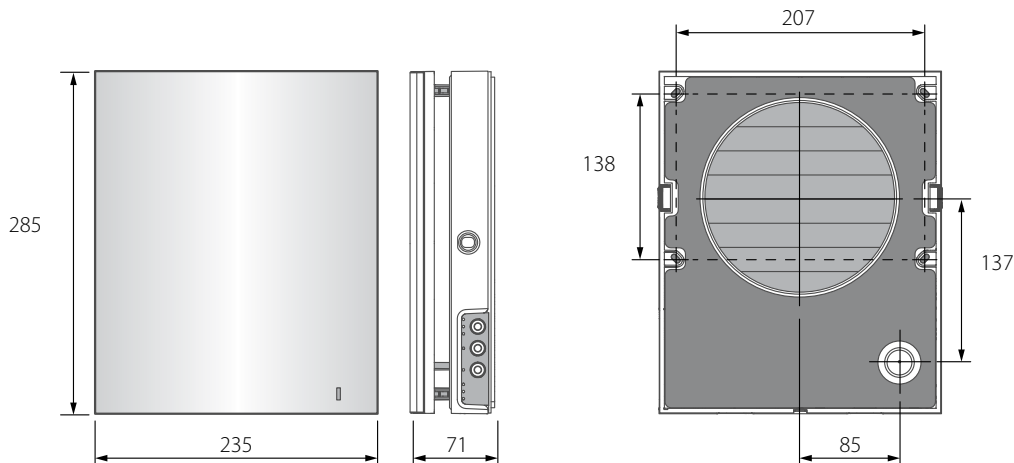

DESIGN AND FUNCTIONING

The ventilator consists of an indoor assembly unit with a decorative front panel, a cartridge, an air duct with a sound absorbing material and an outer ventilation hood.

Cartridge is the basic functioning part of the unit.

It consists of a fan, a regenerator and two filters that ensure primary air filtration and prevent ingress of dust and foreign objects into the regenerator and the fan.

The air shutters in the indoor unit close during the unit standstill and prevent back air drafting.

The ventilation hood to be installed on the outer wall prevents ingress of water and foreign objects into the unit.

VENTILATOR DESIGN

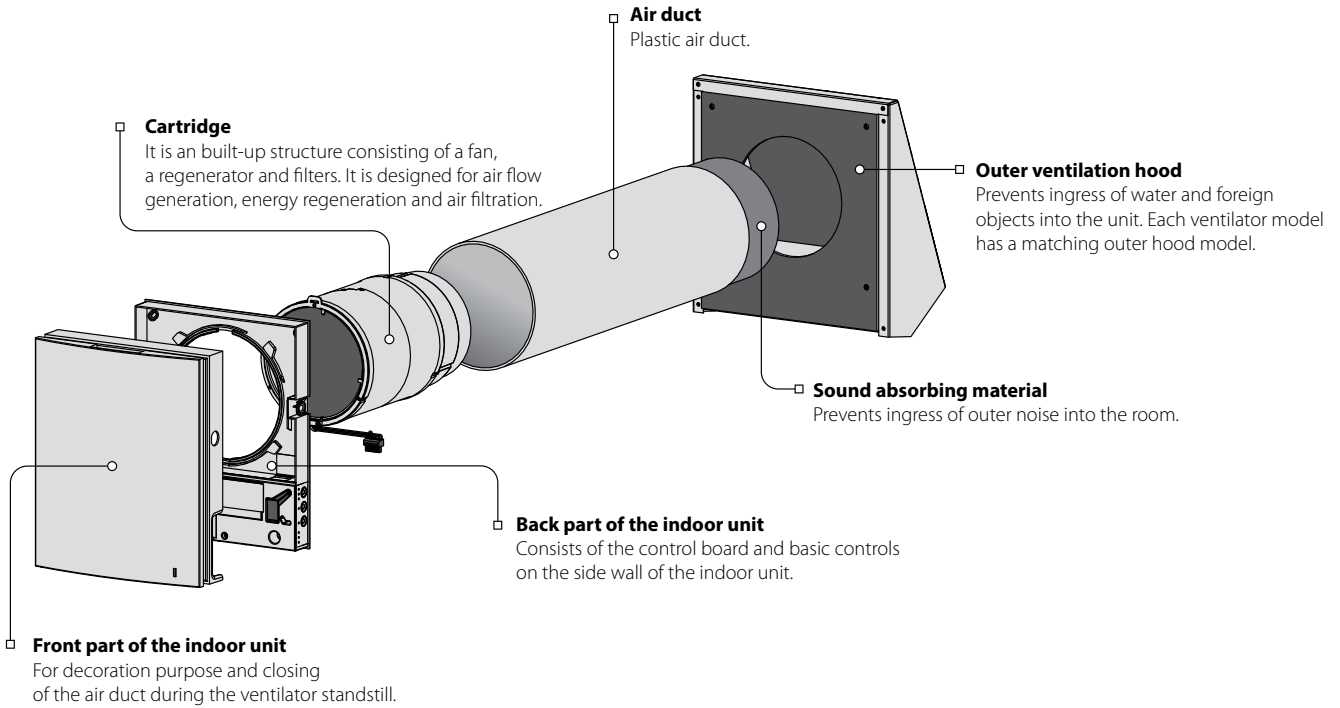

CARTRIDGE DESIGN

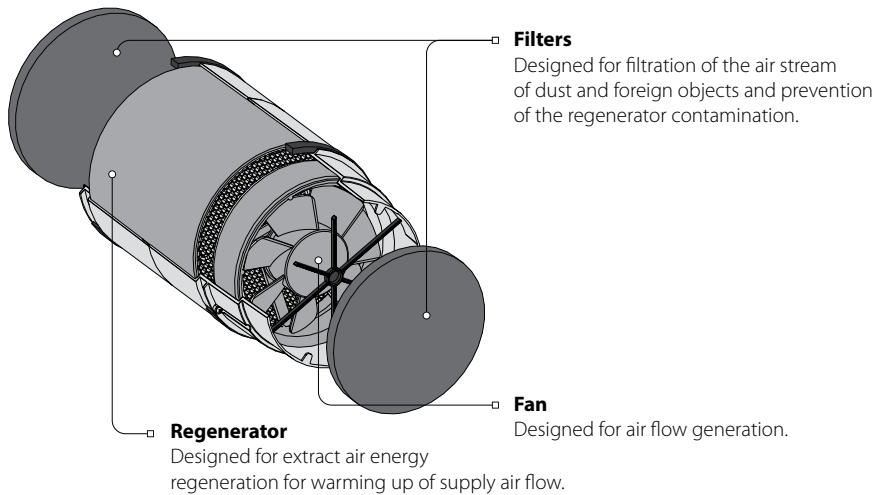

Cartridge is a solid block and cannot be dismantled.

NIBE DVC 10 has a cartridge with removable filters. They are removed for maintenance needs.

A socket connector to be connected to the control board in the back part of the indoor unit is routed from the cartridge.

VENTILATOR OPERATION MODES

Ventilation: the ventilator operates in the permanent air supply or air extract mode at set speed.

Regeneration: the ventilator operates in reversible mode with heat and humidity regeneration in two cycles.

Air supply (available from a mobile device only for DVC 10-50W(L)). All the connected ventilators in the network switch to the air supply mode.

In **Regeneration** mode each operation cycle lasts 70 seconds.

Cycle I.

Warm stale air is extracted from the room. As it flows through the regenerator, it heats and moisturizes the regenerator, transferring up to 97 % heat energy.

In 70 seconds as the ceramic regenerator gets warmed the unit is switched to the air supply mode.

Cycle II.

Fresh intake air from outside flows through the ceramic regenerator and absorbs accumulated moisture and heat up to the room temperature.

In 70 seconds after cooling of the ceramic regenerator the unit is switched to the air extract mode and the cycle is renewed.

FUNCTIONING OF THE LOUVRE SHUTTERS

Shutters are closed.

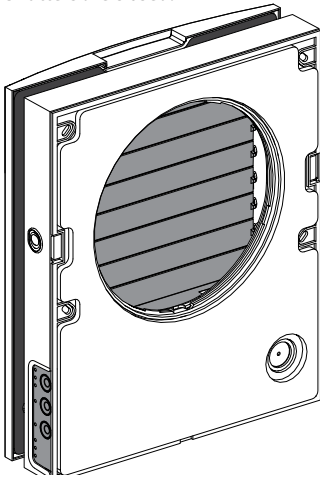

Shutters are open.

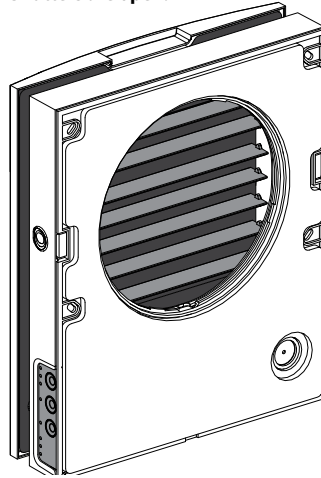

The indoor unit is equipped with air shutters.

During the unit operation the shutters open to let the air stream flow freely through the unit.

After the unit shutdown the shutters close within 2 minutes.

MOUNTING AND SET-UP



READ THE USER'S MANUAL PRIOR TO MOUNTING THE UNIT.



DO NOT BLOCK THE AIR DUCT OF THE INSTALLED UNIT WITH DUST ACCUMULATING MATERIALS, SUCH AS CURTAINS, CLOTH SHUTTERS, ETC. AS IT PREVENTS AIR CIRCULATION IN THE ROOM.

1. Prepare a round core hole in the outer wall. The hole size in the wall is shown below. While preparing a core hole make preparations for layout of the power cable and other required cables.

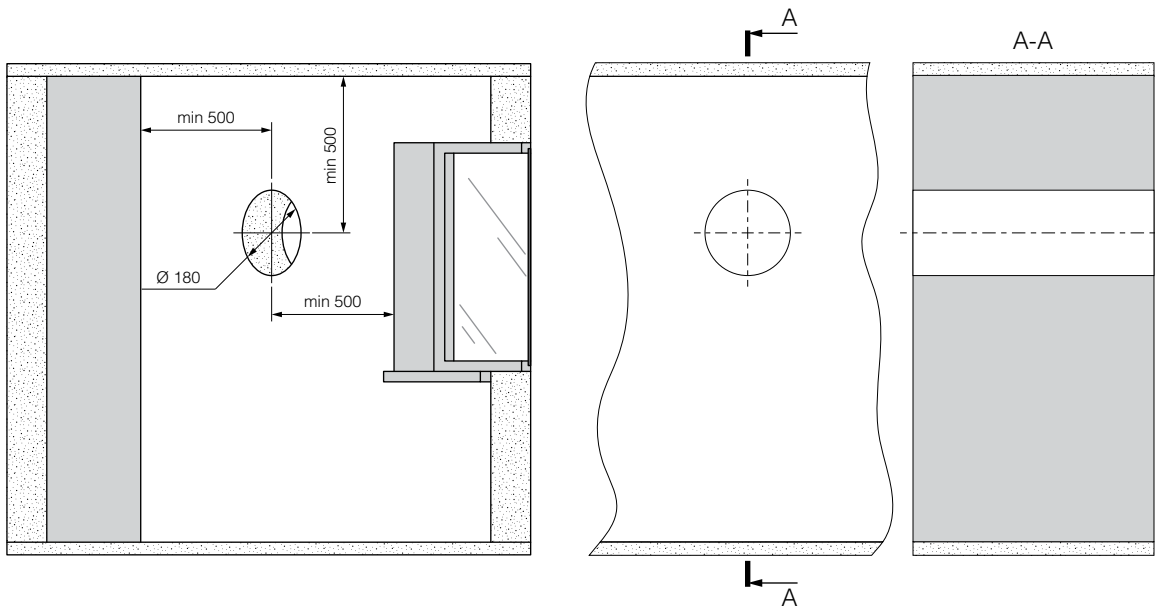

2. Insert the air duct in the wall using the supplied polystyrene wedges.

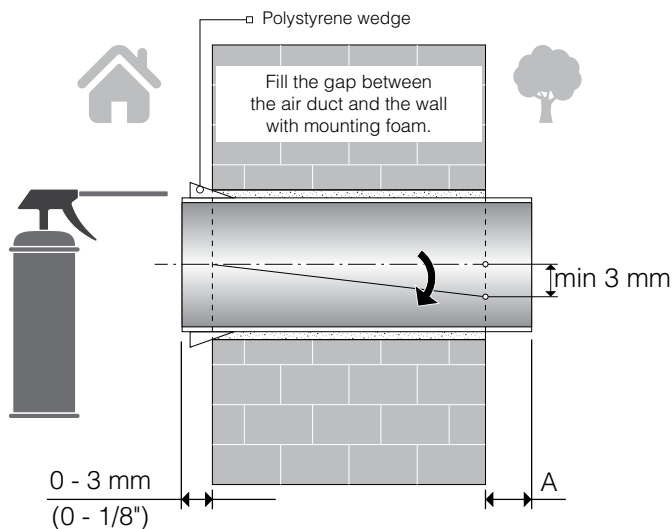

Install the air duct in the wall in such a way as shown on the left. Install the air duct with the minimum slope 3 mm downwards on the outside.

On the outer wall side the air duct end must protrude to a distance that enables installation of the outer ventilation hood. Distance **A** is stated in the installation instruction for the ventilation hood.

Adjustment of the air duct length is possible before and after fixation of the air duct in the wall. In the first case the required length must be calculated before mounting and in the second case sufficient access must be provided on the outer wall after installation of the air duct.

3. Glue the supplied cardboard mounting template with a sealing tape on the indoor wall. Mate the large hole in the template with the air duct. Use a builder's level for horizontal alignment of the mounting template. Mark the openings for dowels from the fastening kit and drill holes to a required depth. Route the power cable from the ventilator outside through the marked opening on the mounting template.

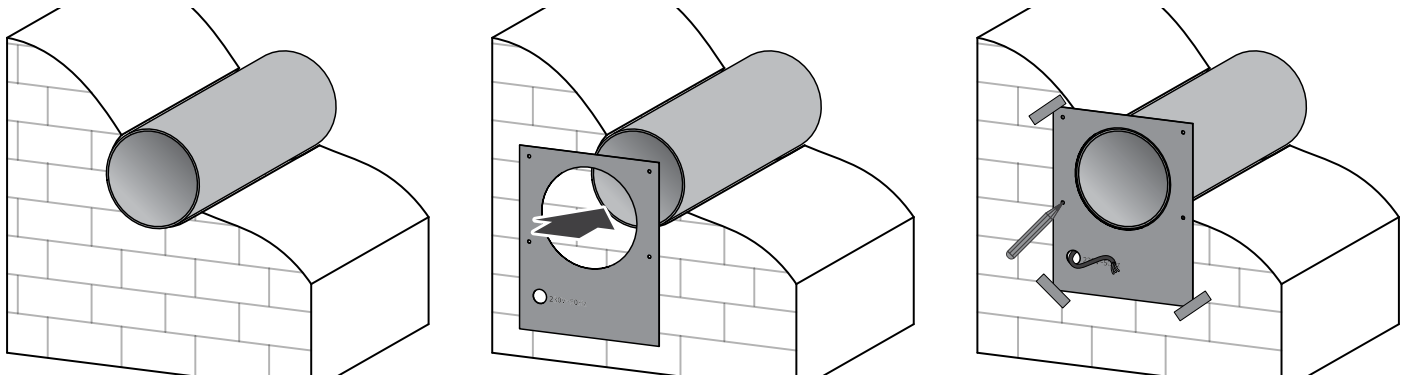

4. Press the side tabs to detach the front part of the indoor unit from its back part.

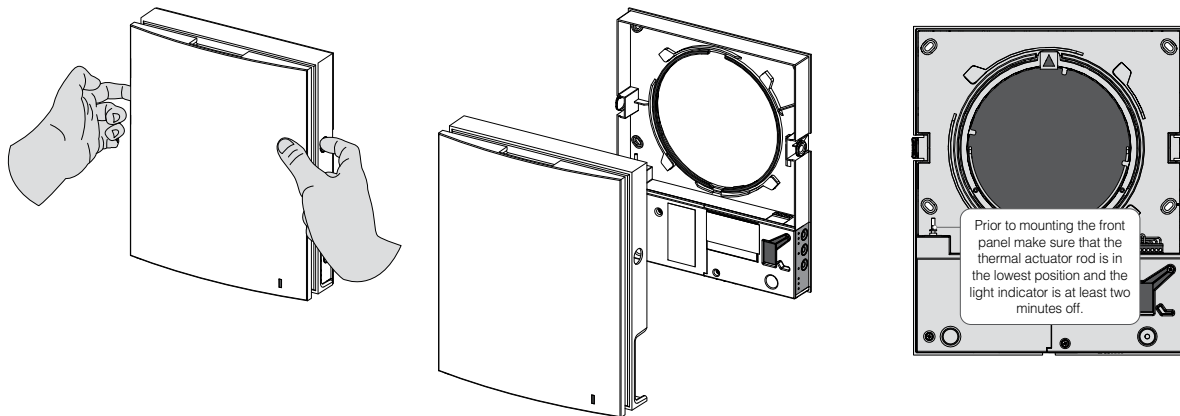

5. Fix the back part of the indoor unit on the wall with the supplied screws. Remove the two screws from the left transparent cover to enable access to the terminals.

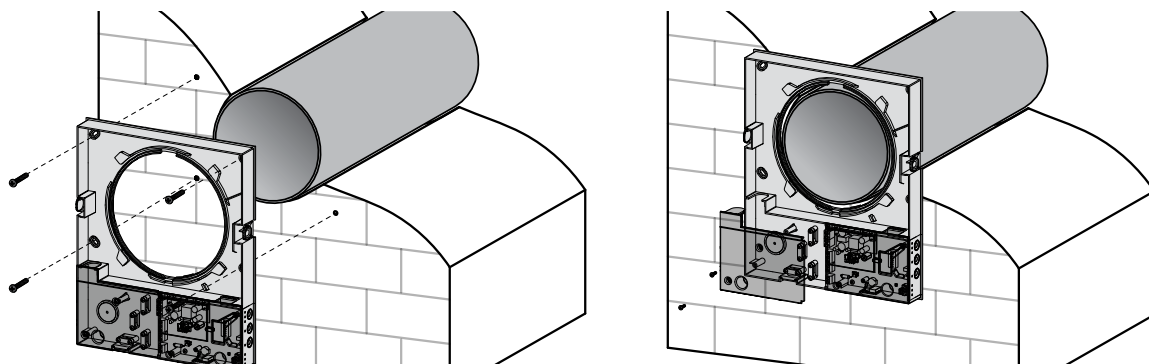

6. Route the power cable as shown in the figure and connect the ventilator to power supply in compliance with the wiring diagram. Fix the power cable and the control cables with the cable clamp. After connection re-install the transparent cover.

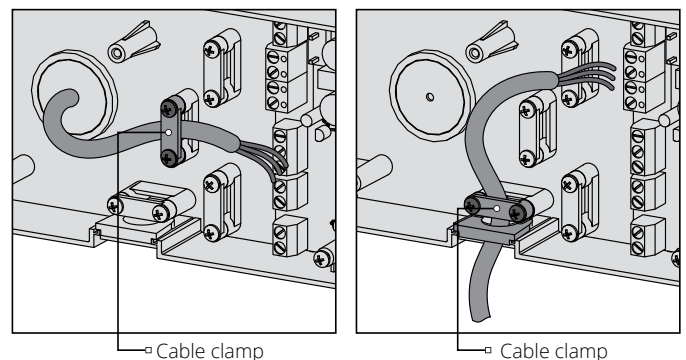

7. Insert the cartridge in the air duct as shown below. Be sure the pointer is directed upwards. Then fix the cable with a clamp and connect the socket connector to the control board.

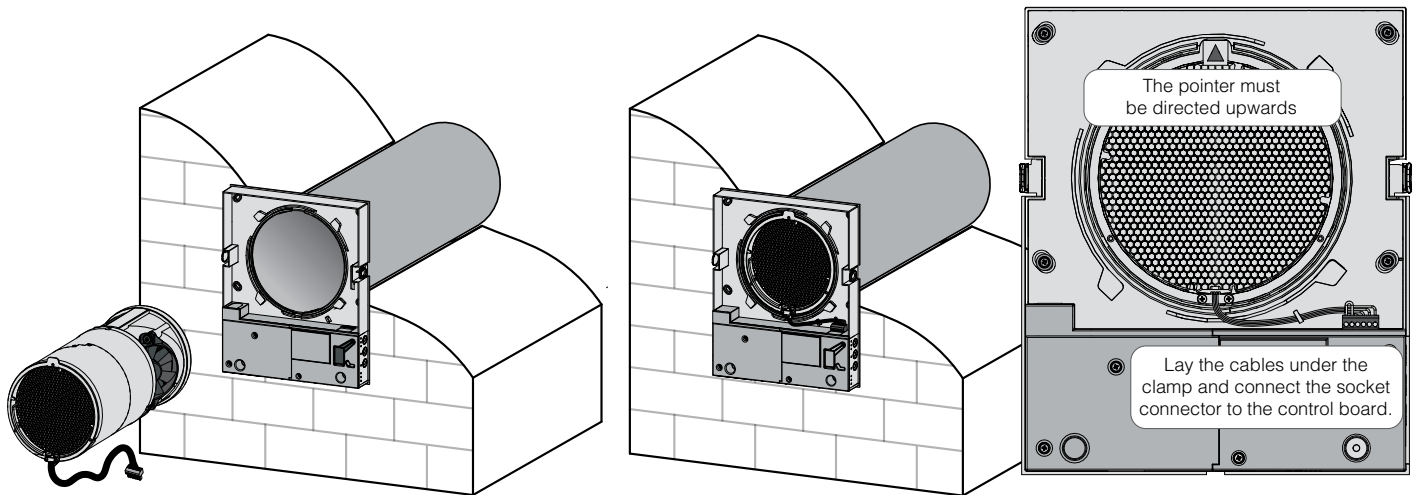

8. Install the front part of the indoor unit.

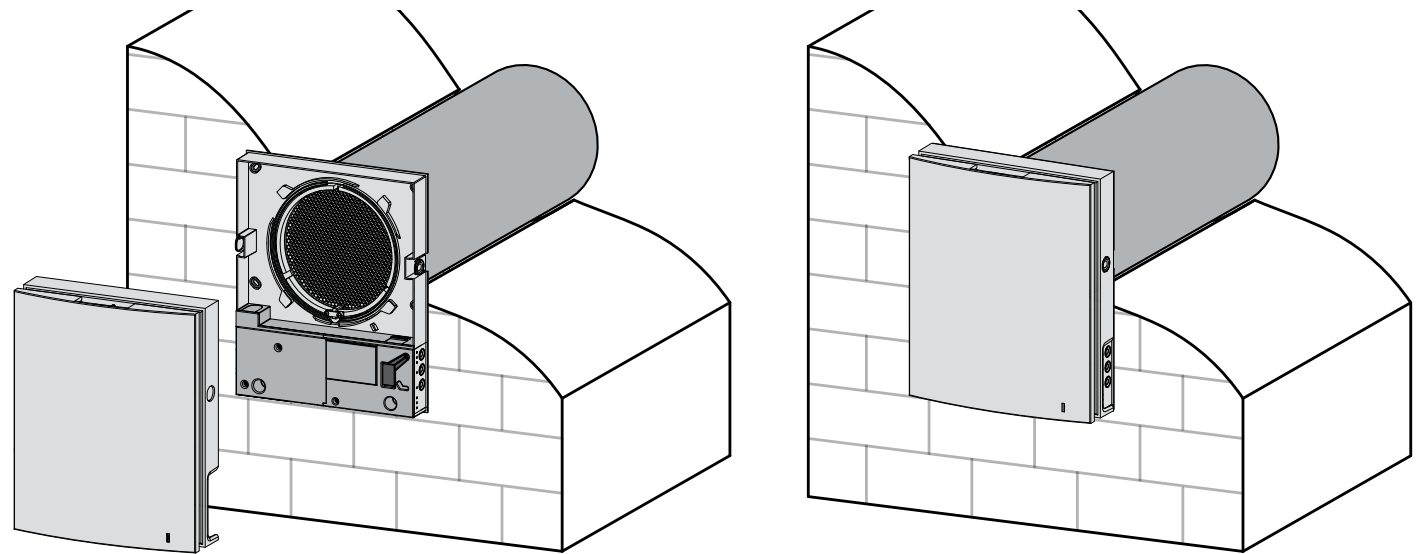

9. Roll the sound absorbing layer to match the air duct diameter with the protecting paper layer outside. Do not remove the paper layer! Insert the sound absorbing roll into the air duct from outside. Insert the roll in the air duct against stop to the cartridge. Make a mark at the end of the air duct, remove the material and cut the roll as marked. Insert the ready roll into the air duct.

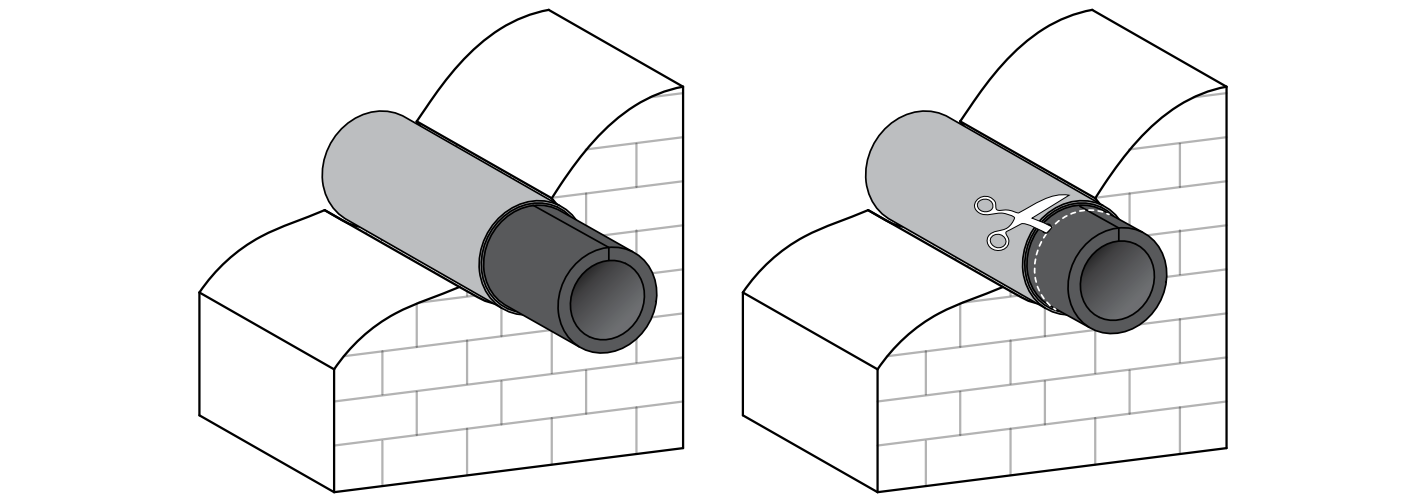

10. Install the outer ventilation hood. For mounting guidelines please refer to the installation instruction for the outer hood.

CONNECTION TO POWER SUPPLY AND CONTROL

DISCONNECT THE UNIT FROM POWER SUPPLY PRIOR TO ANY ELECTRIC INSTALLATION OPERATIONS.



INSTALLATION SHALL ONLY BE PERFORMED BY A PROFESSIONAL ELECTRICIAN QUALIFIED FOR UNASSISTED OPERATIONS WITH ELECTRICAL INSTALLATIONS UP TO 1000 V AFTER CAREFUL STUDY OF THE PRESENT USER'S MANUAL.

THE RATED ELECTRICAL PARAMETERS ARE STATED ON THE RATING PLATE. ANY TAMPERING WITH THE INTERNAL CONNECTIONS IS PROHIBITED AND WILL VOID THE WARRANTY.

The ventilator is rated for connection to single-phase ac 100-230 V/ 50-60 Hz power mains. The automatic circuit breaker (not included in the delivery set) must be integrated in the home electrical wiring. The external circuit breaker position must ensure prompt access for emergency shutdown of the unit. Connect the ventilator to power mains using the pre-wired power cable with the Euro Plug XP.

For electric installations use insulated, durable and heat-resistant electric leads (cables, wires). The minimum total cross section is 0.5 up to 0.75 mm² for the power cable and 0.25 mm² for the control cables. The above wire cross section value is tentative. The control cable must be shielded. While selecting the required wire cross section consider the cable type, its maximum heating temperature, insulation, length and installation method. The installation steps for layout of power and signal cables is shown in «Mounting and setup».

Use copper wires only for all the electric connections!
Connect the wires to the terminal block located on the control board in compliance with the wiring diagram and terminal designations.

EXTERNAL WIRING DIAGRAM

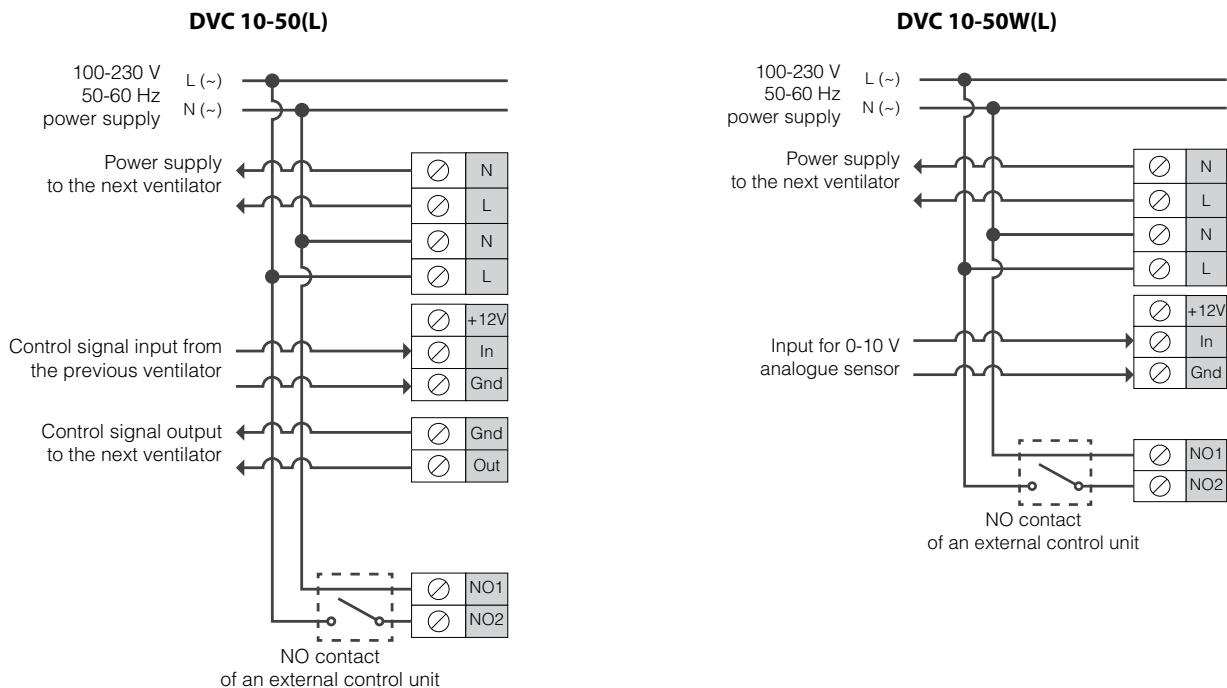

The ventilator design enables connection of external devices with normally open contacts (no-contacts), such as CO₂ sensor, humidity sensor, switch, etc.

On power supply 110-240 V 50/60 Hz to the NO1 and NO2 terminals the ventilator switches to the high speed.

Several ventilators may be series connected and integrated into a network and operated with one Master unit. Two ventilators may be parallel connected by means of connecting their power inputs to the output of the previous ventilator.

In case of series connection or parallel connection of several ventilators power is supplied from a previous ventilator or directly from power mains.

The ventilator design enables connection of external devices with normally open contacts (no-contacts), such as CO₂ sensor, humidity sensor, switch, etc.

On power supply 110-240 V 50/60 Hz to the NO1 and NO2 terminals the ventilator switches to the high speed.

The ventilator design enables connection of an analogue sensor with 0-10 V output voltage (applicable only for DVC 10-50W(L)).

SERIES CONNECTION OF DVC 10-50 VENTILATORS

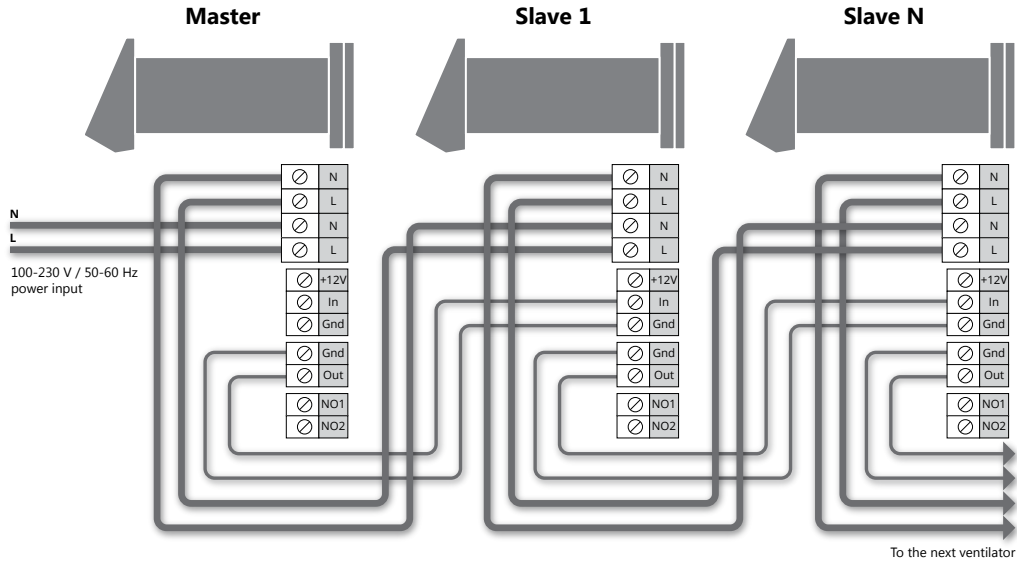

PARALLEL CONNECTION OF DVC 10-50 VENTILATORS

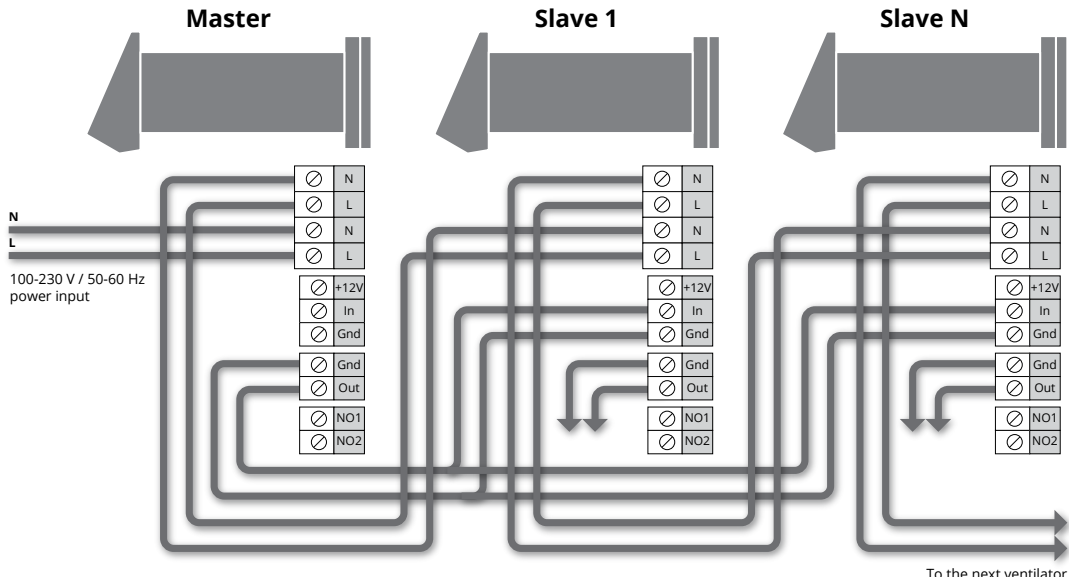

VENTILATOR SETUP

DVC 10-50(L)

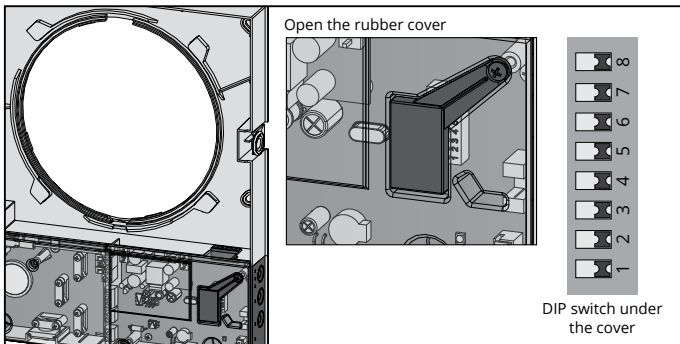

DVC 10-50W(L)

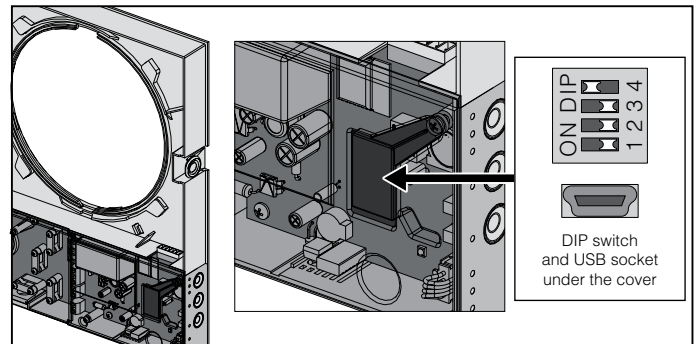































Prior to operating the ventilator set it up using the DIP switch located on the control board. For accessing the DIP switch take off the front part of the indoor unit and uplift the rubber cover.











Prior to operating the ventilator set it up using the DIP switch located on the control board. For accessing the DIP switch take off the front part of the indoor unit and uplift the rubber cover.

The USB socket that enables connection of the unit to a PC is located under the rubber cover.

POSITIONING OF THE DIP SWITCH FOR DVC 10-50(L)

	1	Complete shutdown of the ventilator is enabled. In this switch position the ventilator may be turned off by means of the button on the side control panel.			
	1	Complete shutdown of the ventilator is disabled. In this switch position the ventilator may not be turned off by means of the button on the side control panel.			
Fan rotation direction Use a paired quantity of the ventilators and integrate those with a signal cable to ensure quality balanced ventilation. Set one half of the ventilators to operate in the supply mode and the other half in the exhaust mode.					
	2	Air supply In the switch position the ventilator supplies air in the Ventilation mode. In the Regeneration mode the ventilator starts operation from the air supply phase.			
	2	Air exhaust In the switch position the ventilator extracts air in the Ventilation mode. In the Regeneration mode the ventilator starts operation from the air extract phase.			
Set humidity point The extract air humidity is detected by the humidity sensor in the ventilator. The ventilator goes to the high speed once the indoor air humidity exceeds the set point. Once the indoor air humidity drops down below the set humidity point, the ventilators reverts to the previous speed settings after countdown of the turn-off delay timer.					
Humidity control is off	Set point 40 %	Set point 50 %	Set point 60 %	Set point 70 %	Set point 80 %
 5	 5	 5	 5	 5	 5
 4	 4	 4	 4	 4	 4
 3	 3	 3	 3	 3	 3
Turn-off delay timer After activation of the humidity sensor or a connected external device the ventilator goes to the high speed. After return of the humidity and other parameters to rated values the ventilator reverts to the previous operation mode in set time period.					
Time delay 0 minutes	Time delay 5 minutes	Time delay 15 minutes	Time delay 30 minutes		
 7	 7	 7	 7		
 6	 6	 6	 6		

POSITIONING OF THE DIP SWITCH FOR DVC 10-50W(L)



Ventilator operation modes	
	2
	1
User parameters of the unit and Wi-Fi: set the first and the second jumper to OFF position. Turn power supply to the unit off and on to apply the parameters.	
	2
	1
Slave demo-mode: set the first jumper to ON position and set the second jumper to OFF position. This mode is described in details below. Turn power supply to the unit off and on to apply the parameters.	
	2
	1
Master demo-mode: set the first and the second jumper to ON position. This mode is described in details below. Turn power supply to the unit off and on to apply the parameters.	
	2
	1
To reset the ventilator to the factory settings set the first jumper to OFF position and the second jumper to ON position. Turn power supply to the unit off and on to apply the parameters.	
Reset of filter timer	
	3
To reset the filter timer set the third jumper to ON position and then reset it to OFF position.	
Service mode	
	4
Basic firmware download mode: set the fourth jumper to OFF position. Turn power supply to the unit off and on to apply the parameters.	
	4
Normal operation mode: set the fourth jumper to ON position. Turn power supply to the unit off and on to apply the parameters.	

VENTILATOR CONTROL

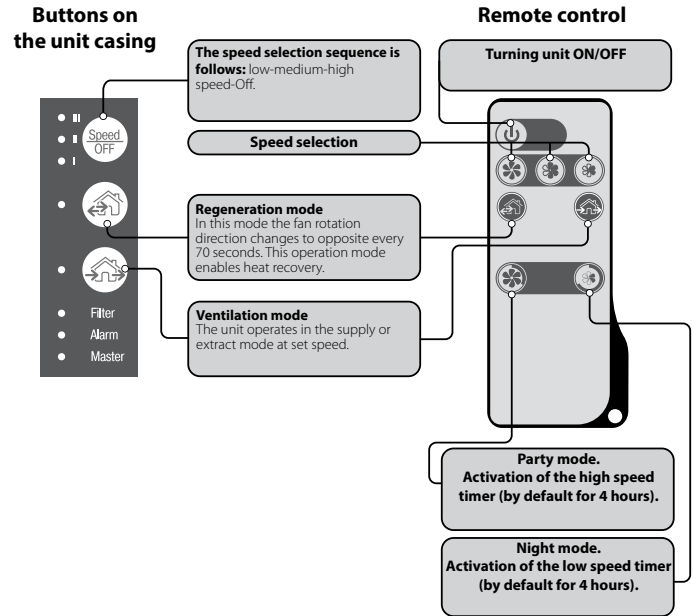





The ventilator is operated with the remote control or the buttons on the side part of the indoor unit, see the picture on the right. In case of series connection or parallel connection of several ventilators the signal from a control unit is received by the Master unit only.



OPERATION OF THE VENTILATOR WITH THE BUTTONS ON THE INDOOR UNIT

	<p>The speed selection sequence is as follows: low-medium-high-OFF. All the units integrated in a single network operate according to the speed settings of the Master unit. I: permanent glowing of the lamp indicator indicates operation of the unit with low speed. Blinking of the lamp indicates activation of the low speed mode timer. I and II: permanent glowing of the lamp indicators I and II indicates operation of the unit with medium speed. I, II and III: permanent glowing of the lamp indicators I, II and III indicates operation of the ventilator with the medium speed. Blinking of the lamp indicators I, II and III indicates activation of the party mode timer or the turn-off delay timer triggered by any connected external sensors or the integrated humidity sensor.</p>
	<p>Regeneration mode. The fan rotation direction changes to opposite every 70 seconds. This mode enables heat recovery.</p>
	<p>Ventilation mode. <u>DVC 10-50(L)</u> The ventilator operates in the supply or extract mode with a set speed. The fan rotation direction depends on DIP-switch positioning setting (extract mode by default). <u>DVC 10-50W(L)</u> The ventilator operates in the supply or extract mode with a set speed. The fan rotation direction depends on PC setting (extract mode by default).</p>
<p><u>DVC 10-50W(L)</u> No glowing of the indicator lamps «Regeneration» and «Ventilation» indicates forced operation of the ventilator in the supply mode. This mode may be activated via the mobile application only.</p>	
<p>Filter</p>	<p>Filter replacement indicator. 90 days after installation of the cartridge the filter replacement indicator starts glowing (in case of non-sop operation). In this case replace or clean the filters as described in Maintenance section. <u>DVC 10-50(L)</u> In case of a series connection the indicator of the first ventilator is permanently on. The filter timer is reset once the cartridge socket connector is disconnected from the circuit board. <u>DVC 10-50W(L)</u> After replacement of the filters reset the timer using the DIP switch, the mobile application or PC application.</p>
<p>Alarm</p>	<p>Emergency shutdown indicator. Permanent glowing of the Alarm indicator of the Master unit indicates an alarm in the network of the connected ventilators. Its blinking indicates shutdown of a specific ventilator in the network. In case of an emergency shutdown of a ventilator the defective ventilator is marked with the blinking Alarm indicator. All the connected ventilators are also stopped.</p>
<p>Master</p>	<p>Permanent glowing of the lamp indicator indicates the leading unit in the network (Master unit). Only for <u>DVC 10-50W(L)</u>: blinking of the indicator means it is a driven unit (Slave) and it has no connection to the Master unit. No glowing of the lamp indicator means that this ventilator is a Slave unit and it is connected to the Master unit.</p>
<p><u>DVC 10-50W(L)</u> Synchronous blinking of all the lamp indicators on the casing of the ventilator means activated setup mode via a PC. In this case the fan shuts down.</p>	

REMOTE CONTROL OF THE VENTILATOR

	<p>Turning the unit on/off. The unit may be turned off only if it is enabled by the settings. Reset of alarm and timer settings.</p>
	<p>Speed selection: high-medium-low respectively.</p>
	<p>Regeneration mode. The fan rotation direction changes to opposite every 70 seconds. This mode enables heat recovery.</p>
	<p>Ventilation mode. The ventilator operates in the supply or extract mode with a set speed. The fan rotation direction depends on DIP-switch positioning (extract mode by default).</p>
	<p>  Party mode: the timer activates operation of the unit with the high speed for a set time period, 4 hours by default. The setting may be edited during setup of the ventilator or using the mobile application.  Night mode: the timer activates operation of the ventilator with the low speed for a set time period, 8 hours by default. The timer setting may be changed during setup of the ventilator or using the mobile application. The ventilator reverts to operation with a previous speed setting upon elapse of the set time period. Press any speed key to deactivate the timer or press the timer control button once again. </p>

VENTILATOR SETUP

Download and install the software to setup the ventilator.

Download link: <http://www.nibe.se/dvc10>

Download the programme to control the ventilator and install it to your smart phone or tablet.

Download link: https://play.google.com/store/apps/details?id=com.embarcadero.NIBE_DVC_10

<https://itunes.apple.com/us/app/nibe-dvc-10/id1176860822?mt=8>

Connection of the ventilator to PC:

- Start the application NIBE DVC 10.exe at your PC.
- Take off the front part of the indoor unit for accessing the DIP switch and USB connector on the control board under the rubber cover. For details, please refer to Ventilator Setup).
- Connect the ventilator and PC using a USB to mini USB cable.
- Select the menu language prior to starting operation (3).
- Select a required unit from the dropdown list **Select device** (1). When a ventilator is connected to a PC, the program automatically detects the connected ventilator and it is displayed in the dropdown list **Select device**.
- Select an operation mode for the ventilator in the network (2). Available parameters for the **Master** mode: 4-13. Available parameters for the Slave mode: 4-5.

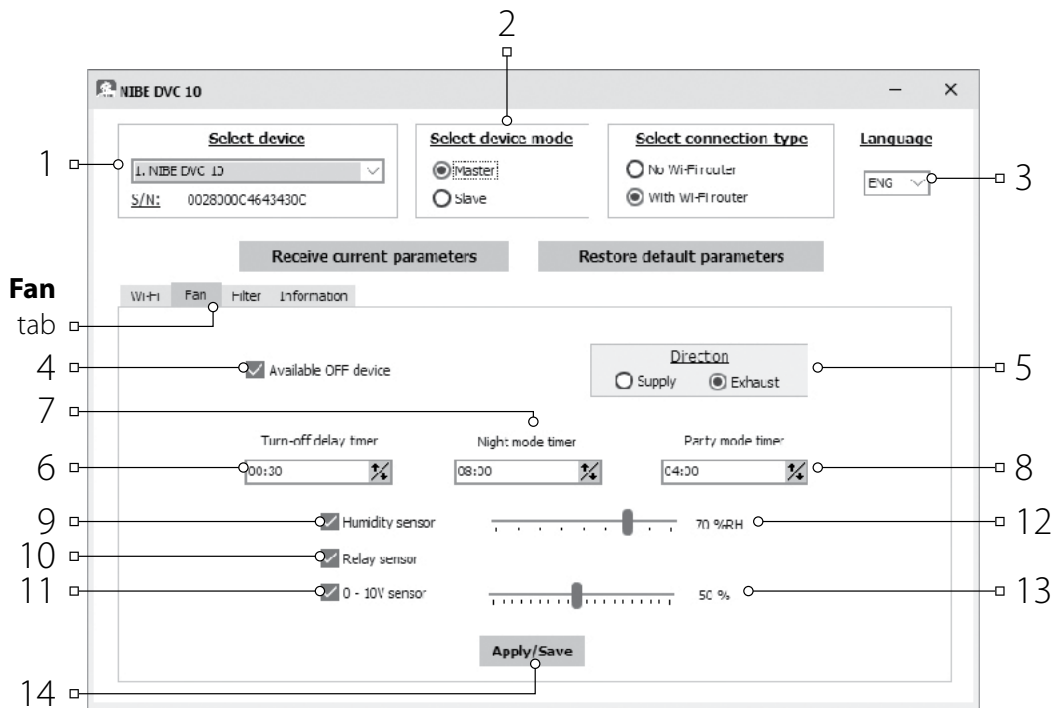

Ventilator setup

Prior to starting setup of the unit open the tab **Fan**.

- **Receive current parameters:** reading the settings from the connected unit and saving the in the program.
- **Restore default parameters:** resetting the factory settings in the connected unit.
- **Available OFF device (active by default):** enabling/disabling of the unit turning off. The attempt to turn the unit off will turn it to low speed mode. To disable the function uncheck «Available OFF device».
- **Direction:** setting rotation direction of the fan in the **Ventilation** mode. This parameter sets the fan rotation direction in the **Regeneration mode** too.



IF SEVERAL VENTILATORS ARE INTEGRATED IN A COMMON NETWORK IT IS RECOMMENDED TO SET OPPOSITE ROTATION DIRECTION FOR EACH VENTILATION SET CONSISTING OF 2 UNITS TO AVOID EXCESSIVE OR NEGATIVE PRESSURE IN A PREMISE.

- **Turn-off delay timer:** setting reset time to a previous operation mode for the ventilator after activation of any connected sensors or the built-in humidity sensor.
- **Night mode timer:** setting reset time to the low speed mode after activation of the night mode, factory setting 8 hours.
- **Party mode timer:** setting changeover time for high-speed mode after activation of the Party mode, factory setting 4 hours.
- **Humidity sensor:** activation of the humidity sensor. When the indoor humidity exceeds the set point (12), the unit changes to the high speed. When the indoor humidity drops down below the set point, the turn-off timers starts countdown and then the unit changes to the previous speed.
- **Relay sensor:** activation of the external relay sensor (10). When the no-contact of the external relay sensor is closed, the unit changes to the high speed. When the no-contact is open the turn-off timers starts countdown and then the unit changes to the previous speed.
- **0 - 10 V sensor:** activation of the external analogue sensor 0-10 V. When a 0-10 V control signal value exceed the set point (13), the ventilator changes to the high speed. As the control signal value falls down below the set point, the turn-off timer starts its countdown and upon its elapsing the ventilator reverts to operation with the previous speed.
- **Apply:** press the button (14) to apply the parameters in the selected tab.

RESET FILTER TIMER FOR DVC 10-50W(L)

- Start the program [NIBE DVC 10.exe](#) at your PC.
- Connect the ventilator and PC using a USB to mini USB cable.
- Select a required unit from the dropdown list **Select device** (1).
- Select the tab **Filter**.
- Press the button **Reset filter timer** (3) to reset the timer. After replacement of the filters the operating hours are displayed above the button (2).

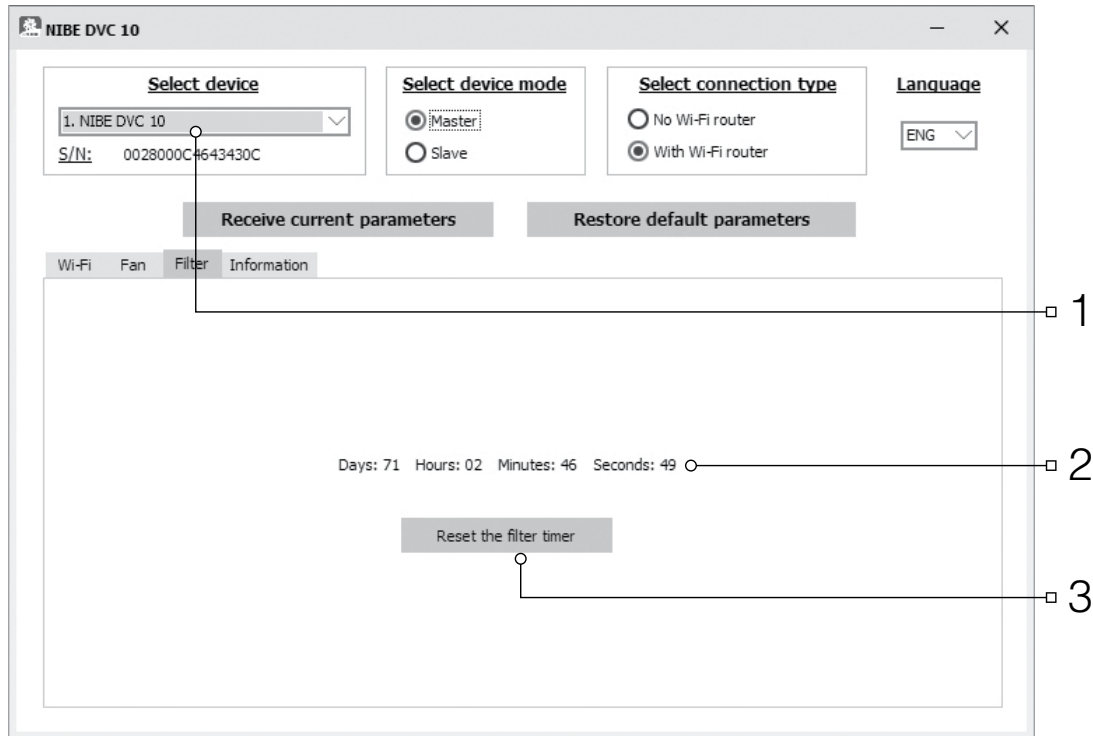

EMERGENCY SHUTDOWN OF THE UNIT DVC 10-50W(L)

Emergency shutdown of all the ventilators happens if the fan shutdown lasts above 5 seconds. In case of emergency shutdown of any ventilator in a network all the other ventilators also stop.

Alarm is confirmed by a respective alarm indication for all the ventilators in the network, see page 14.

To reset the alarm troubleshoot the motor jam, turn the ventilator off and restart it using the button  on the indoor unit or the button  on the remote control.

If the alarm indication is still active, please refer to the Seller. Cut off power supply to a defective unit to enable operation of the other units in the network.











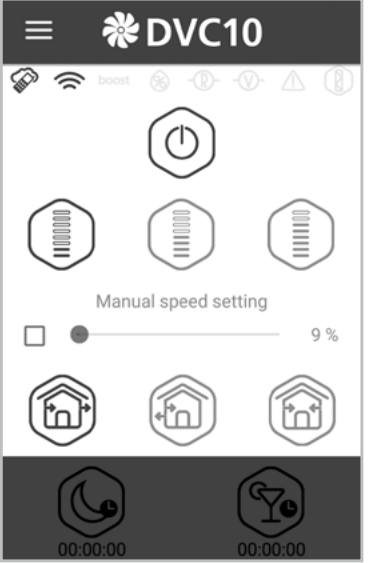



VENTILATOR OPERATION WITH THE MOBILE APPLICATION FOR DVC 10-50W(L)

To enable operation of the unit with a mobile device install the **NIBE DVC 10** application to your mobile device. The application is available for download at **App Store** **Google Play** or via the QR code at the bottom of the page.

Your mobile device must have the operation system matching the following parameters:

- Version 7 or later for iOS. Compatible with iPhone, iPad, iPod.
- Version 4 or later for Android.

After installation of the application turn the unit on and connect your mobile device to a wireless access point. Start the application for operation of the unit at your mobile device. Detailed description of the connection to Wi-Fi read at page 21, 24.

	Turn unit on/off.	
	Selection of pre-set speed. Low, medium, high speed respectively.	
	Manual speed setup. To activate the scroll bar check it.	
	Ventilation mode. The ventilator operates in the supply or extract mode with a set speed. The fan rotation direction depends on PC setting (extract mode by default).	
	Regeneration mode. The fan rotation direction changes every 70 seconds. This mode enables heat recovery.	
	Supply mode. The ventilator operates exclusively in the supply mode.	
	Night mode: low speed timer activation for set speed, by default for 8 hours. The timer setting is set during setup of the ventilator via a PC or the mobile application.	
	Party mode: high speed timer activation, by default for 4 hours. The timer setting is set during unit setup via a PC or the mobile application.	
	Current type of connection to the ventilator. Home connection or connection via a cloud server through Internet respectively.	
	Wi-Fi connection indicator.	
boost	High speed activation indicator. It goes on after activation of any sensor. This mode has higher priority as compared to the Party timer or Night timer mode. When this mode is activated, all the other modes of the turn-off delay timer countdown (from 0 up to 24 hours, factory setting 30 minutes) the ventilator reverts to the previous mode. Press Power to deactivate this operation mode.	
	Humidity indicator. It glows if the indoor humidity is above the set point.	
	Indicator of external relay sensor. It glows if the external relay sensor is activated.	
	Indicator of external analogue sensor 0-10 V. It glows if a set value of the external sensor is exceeded.	
	Emergency shutdown indicator. It glows in emergency case.	
	Indicator button for resetting the filter timer. It glows after 90 days of non-stop operation of the unit. Pressing the button will reset the filter timer of the Master unit only. All the units are equipped with a filter timer that has a nonvolatile medium. To reset the filter timer of the Slave units set the DIP switch 3 to a respective position or use a downloaded program at your PC.	



Download application at **App Store**

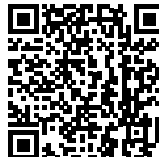

Download application at **Google Play**

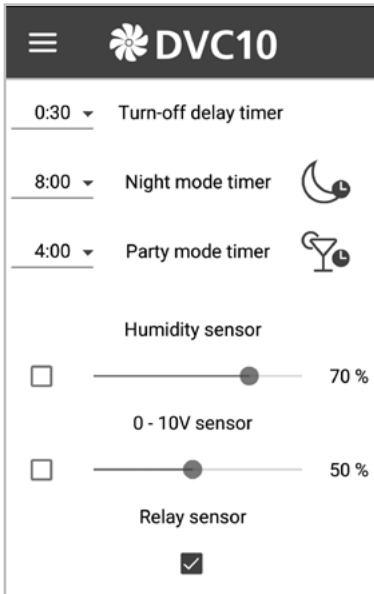

Configuration menu

Press the Menu button (☰) to open the configuration menu and select item **Settings**. This menu settings are similar to the settings described for the application for PC, page 15.

WIRELESS CONNECTION OF SEVERAL VENTILATORS

The unit operates in two modes:

Master. The unit acts as a leading unit in the network. All the Slave unit and mobile devices are connected to the Master unit via Wi-Fi. The Master unit is operated by means of a mobile device, the remote control or the touch buttons on the unit casing. The control signal is automatically transferred to the connected Slave units. In this mode the unit responds to a signal from sensors, as a humidity sensor, an external digital sensor, an external analogue sensor 0-10 V and changes its operation mode respectively.

Slave. The unit acts as a driven unit in the network. The Slave unit responds to a signal from the Master unit only. Any other signals from other controls are ignored. In this mode the ventilators ignore any other signals from the sensors. In case of communication loss with the Master unit above 10 seconds the unit is turned off.

There are two wireless connection options:

1. Connection of up to 4 Slave units or mobile devices to the Master unit with its own wireless access point.

In case of connection of four Slave units to the Master unit with its own wireless access point a mobile device may not be connected.

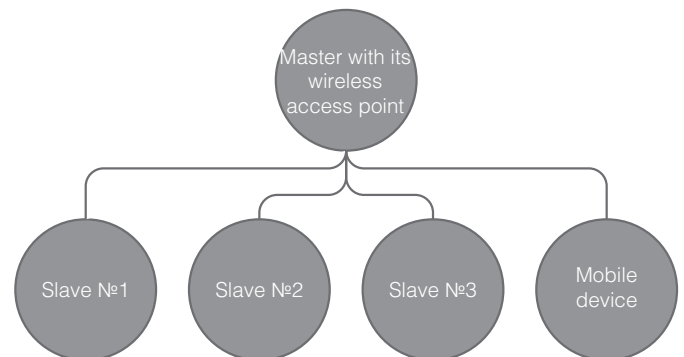

2. The Master units, the Slave units and the mobile devices are connected to a wireless access point of the Wi-Fi router.

In this case the Master unit is able to operate 32 Slave units. Please note that the Wi-Fi routers may have individual limitations for the maximum number of connected devices.

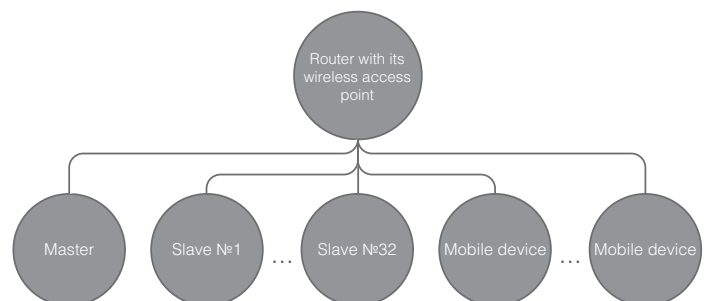

If the Wi-Fi router capacity is not enough to connect a required number of the units, you may use an extra wireless access point to connect the other units. Optionally connection of several Master units to the network for arranging a zone control is also possible.



CONFIGURING THE UNIT IN MASTER MODE ACCORDING TO THE DIAGRAM NO. 1:

- Start the software at your PC to set up the unit.
- Connect the unit and PC using a USB to mini USB cable.
- Select a required device from the dropdown list (1).
- Select Master for required device mode (2).
- Select No Wi-Fi router for the connection type (3).
- Open the tab Wi-Fi (4).
- Select the type of security for the Master point (5). It is an optional requirement.
 - Open means no password protection.
 - WPA_PSK means a password protected encryption.
 - WPA2_PSK means a password protection encryption.
 - WPA_WPA2_PSK means a password protection encryption.

Enter a password for the Master wireless access point (6). The default Wi-Fi password is 11111111.

Select a channel for the Master wireless access point (7). It is an optional requirement.

Apply and save the selected parameters (8).

S/N: a unique serial number of the device. It is displayed in the name of the Master wireless access point and is stated on the unit control board.

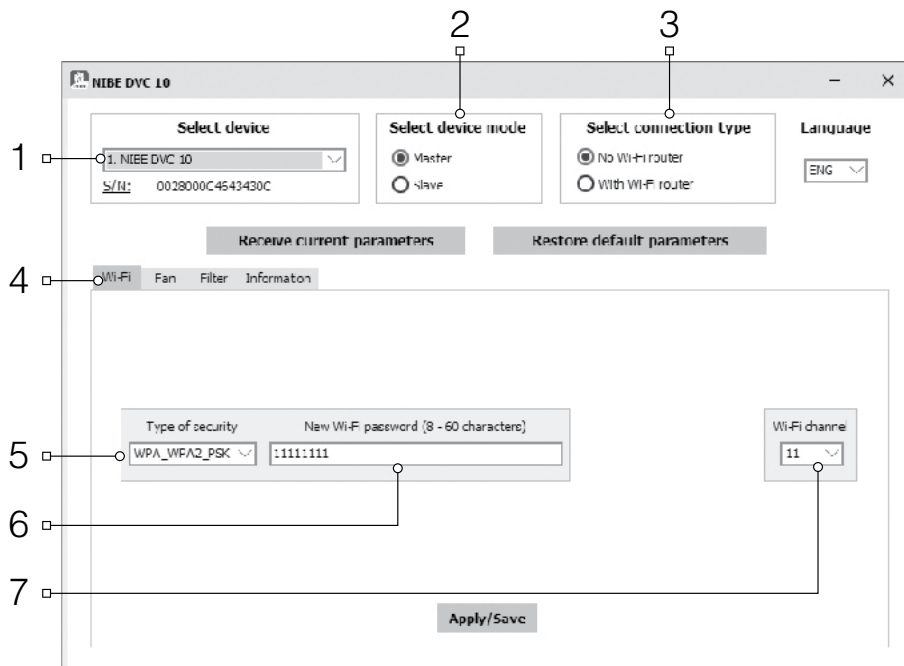

CONNECTION OF A MOBILE DEVICE TO THE UNIT ACCORDING TO THE DIAGRAM NO. 1:

- Install the software to your mobile device.
- Connect the Master unit with configurations according to the diagram No. 1.
- Activate Wi-Fi in the system menu of the mobile device.
- Connection to a wireless access point of the Master unit is as follows:
 - ☞ Wi-Fi name: «FAN» + 16 characters of the serial number of the Master unit as stated on the control board.
 - ☞ Wi-Fi password by default: 11111111 (editable).
- Start the installed application at your mobile device.

In the program menu open the connection page (1-2) and select the connection type Default (3).

The connection name is generated automatically and it can not be edited or deleted. It is specifically designed for connection to a device according to the diagram No. 1.

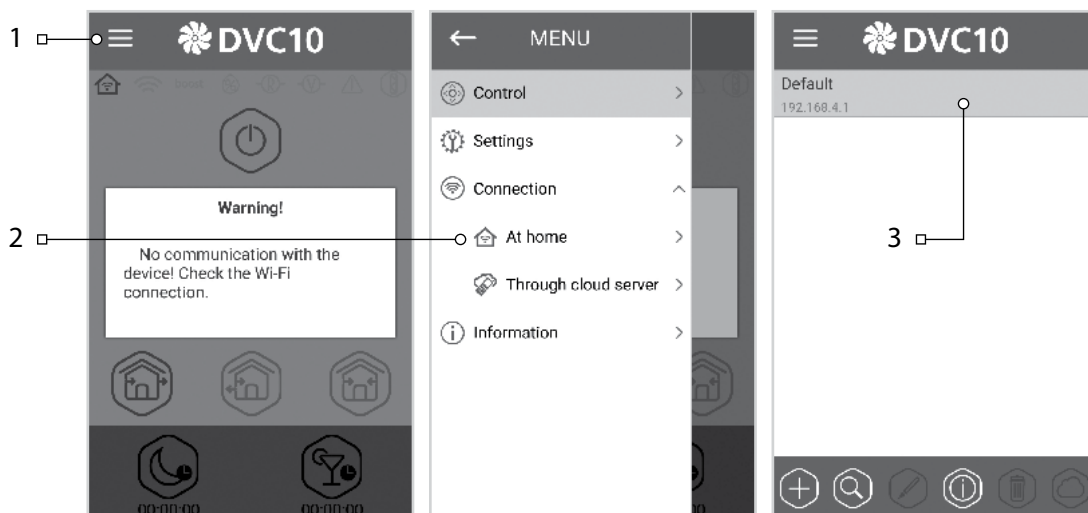

Note: If you use a ventilator that was previously connected to a PC and has edited settings, first apply the settings of the Master unit and set the unit up for operation according to the diagram No. 1.

CONFIGURING THE UNIT IN SLAVE MODE ACCORDING TO THE DIAGRAM NO. 1

- Start the software at your PC to set up the ventilator.
- Connect the ventilator to a PC using a USB to mini USB cable.
- Select a required device from the dropdown list (1).
- Select Slave for required device mode (2).
- Select No Wi-Fi router for the connection type (3).
- Open the tab Wi-Fi (4).
- Press Search Wi-Fi for the Master unit (5). It is an optional requirement.
- Enter or select from the list the name of a wireless access point of the Master unit (6). The Wi-Fi name must be as follows: «FAN» + 16 characters of the serial number of the Master unit as stated on the control board.
- Enter the Wi-Fi password of the Master unit (7). Wi-Fi password by default: 11111111.
- Set a unique number for each Slave unit (8) from 1 to 32 in a consequent order.
- Apply and save the selected parameters (9).
- If all the parameters are entered correct and the Master unit is turned on, within 10 seconds the tab (10) is displayed as Master connected the tab (11) as Wi-Fi connected.

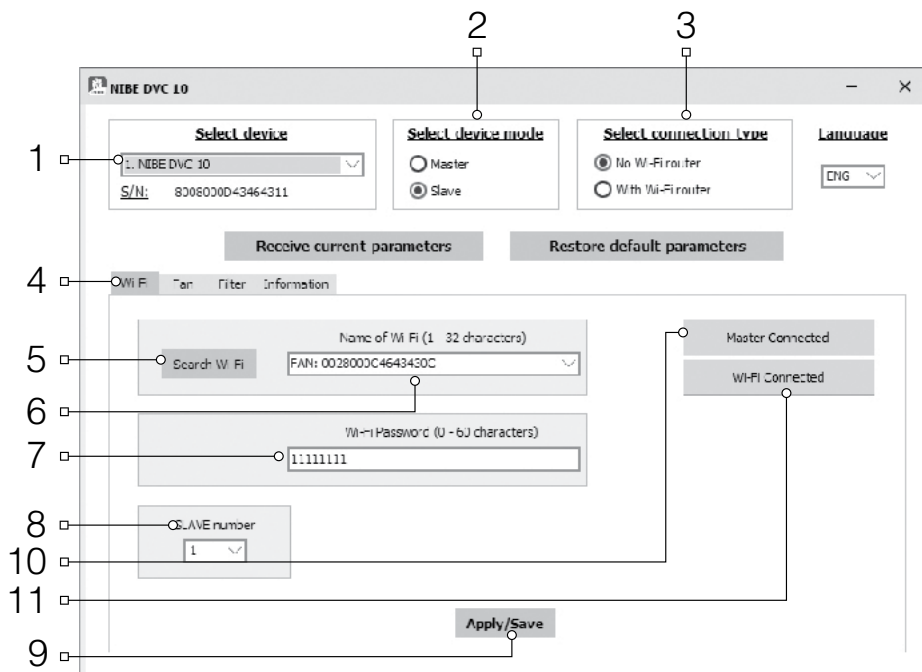

Check the busy numbers using the installed mobile application. For doing that open the connection menu (1-2), select the connection to the Master unit (3) and open the Slave status page (4). All the free numbers are highlighted grey.

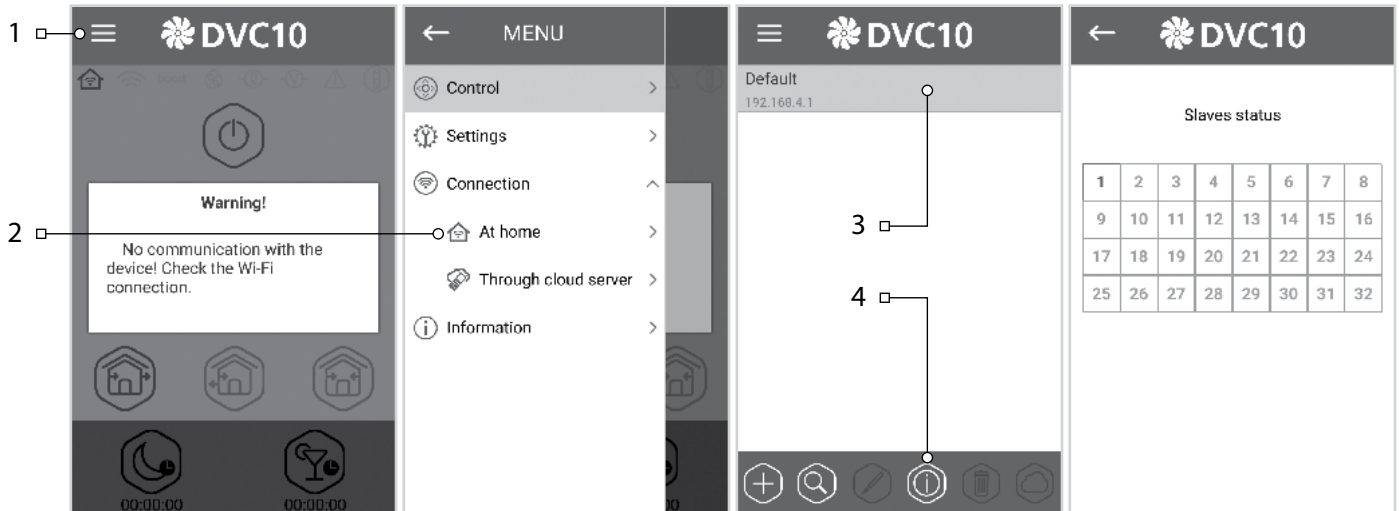

CONFIGURING THE UNIT IN MASTER MODE ACCORDING TO THE DIAGRAM NO. 2

- Start the software at your PC to set up the unit.
- Connect the ventilator to a PC using a USB to mini USB cable.
- Select a required device from the dropdown list (1).
- Select Master for required device mode (2).
- Select with Wi-Fi router for the connection type (3).
- Open the tab Wi-Fi (4).
- Press Search Wi-Fi (5). It is an optional requirement.
- Enter or select from the list the name of a wireless access point of the router (6).
- Enter Wi-Fi password for the router (7).
- Set a free IP address for the Master unit (8). The IP address must match the current network and be unique. Detection of a free IP address is described below.
- Apply «Standard gateway» for the Master unit (9). It must be consistent with the IP-address of the router. This parameter enables coordinated operation of the ventilator with a cloud server through internet.
- Apply and save the selected parameters (10).
- If all the parameters are entered correct and the Wi-Fi router point is turned on, within 10 seconds the tab (11) is displayed as Wi-Fi connected.

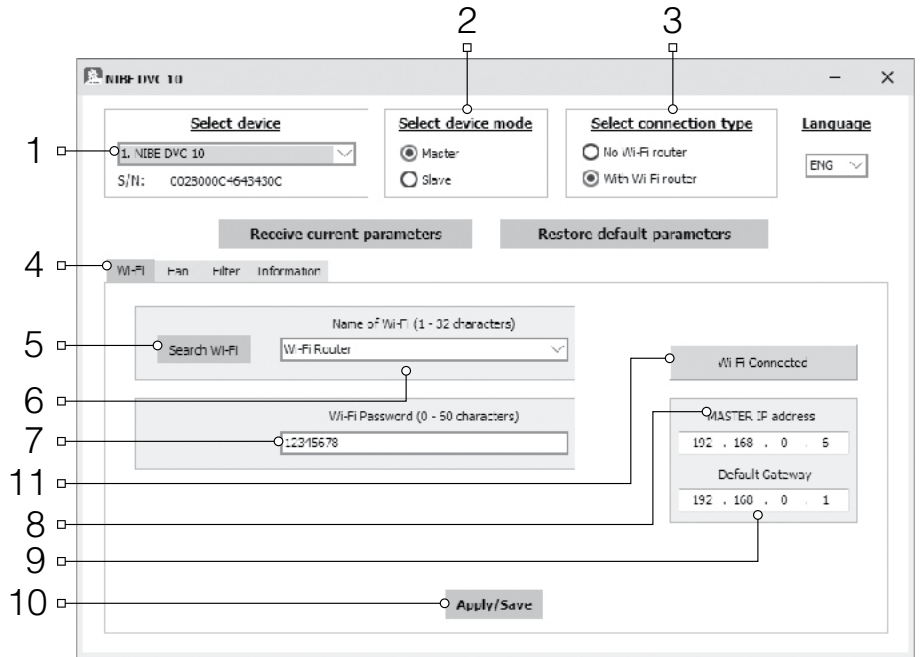

Detection of a free IP address for the Master unit and standard gateway address is as follows:

1. Open the window of the command line: press combination Win+R and enter «cmd» in the appeared window «Run», then press Enter.
2. Select the command «ipconfig» in the appeared window and press Enter.
3. The line «Default-Gateway» indicates the router IP-address. Example: «Basic gateway : 192.168.0.1»
4. Enter this address in the field «Default-Gateway» (9) in the programme for the ventilator setup.
5. Detect a free IP address for the Master unit: enter the command «ping» in the command line, IP-address of the router, change the fourth address field from 1 to 254 and press Enter until the line «This node is not available» appears. Example: «ping 192.168.0.2»+»Enter».
6. Enter the selected available address in the field «Master IP address» for setup of the ventilator.

CONFIGURING THE UNIT IN SLAVE MODE ACCORDING TO THE DIAGRAM NO. 2

- Start the software at your PC to set up the unit.
- Connect the ventilator to a PC using a USB to mini USB cable.
- Select a required device from the dropdown list (1).
- Select Slave for required device mode (2).
- Select With Wi-Fi router for the connection type (3).
- Open the tab Wi-Fi (4).
- Press Search Wi-Fi (5). It is an optional requirement.
- Enter or select from the list the name of a wireless access point of the router (6).
- Enter Wi-Fi password for the router (7).
- Set a unique number for each Slave unit (8) from 1 to 32 in the consequent order. Check the busy numbers using the installed mobile application, see page 20.
- Enter the IP address of the Master unit (10) for the Slave unit to be connected.
- Set the Slave IP address (9). It is an optional requirement.
 - ☞ Set **DHCP** to enable automatic assigning of the IP address during connection to router.
 - ☞ Set **Static** to enable manual assigning of the IP address for the Slave unit. The assigned address must match the current network and be unique. Detection of a free IP address is described below.
- Apply and save the selected parameters (11).
- If all the parameters are entered correct and the Master unit is turned on, within 10 seconds the tab (12) is displayed as Master connected and the tab (13) as Wi-Fi connected.

Detection of a free IP address for the Slave unit is as follows:

1. Open the window of the command line: press combination Win+R and enter «cmd» in the appeared window «Run», then press Enter.
2. Select the command «ipconfig» in the appeared window and press Enter.
3. The line «Default gateway» indicates the router IP-address. Example: «Basic gateway : 192.168.0.1».
4. Detect a free IP address for the Slave unit: enter the command «ping» in the command line, IP-address of the router, change the fourth address field from 1 to 254 and press Enter until the line «This node is not available» appears. Example: «ping 192.168.0.3»+»Enter».
5. Enter the selected available address in the field Slave IP address» for setup of the ventilator.

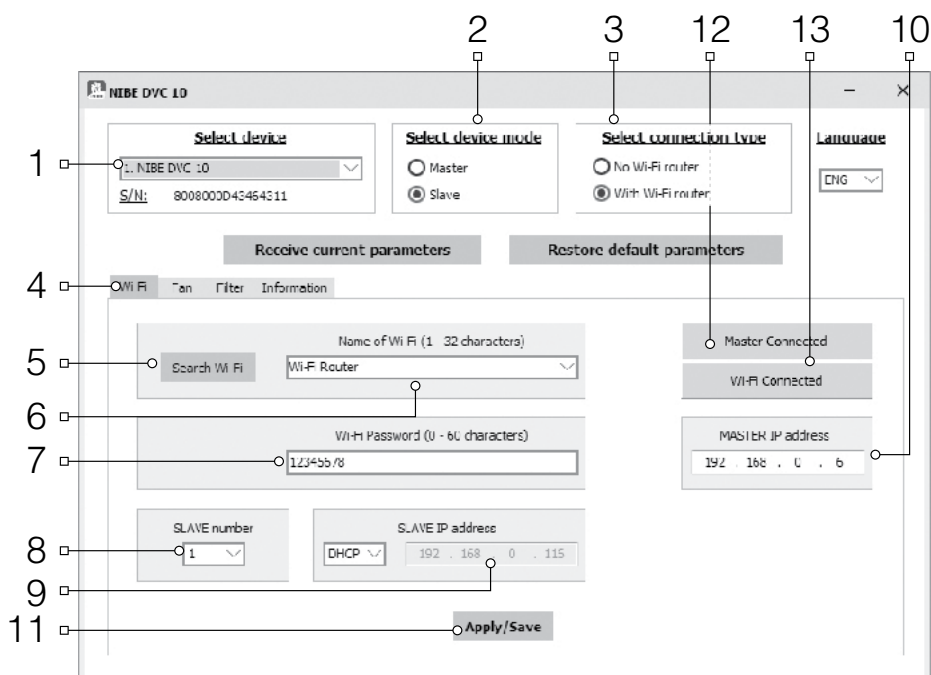

CONNECTION OF A MOBILE DEVICE TO THE UNIT ACCORDING TO THE DIAGRAM NO. 2

- Install the software to your mobile device.
- Connect the Master unit with configurations according to the diagram No. 2.
- Activate Wi-Fi in the system menu of the mobile device.
- Connect to a wireless access point as follows:
- Start the installed mobile application.
- In the menu program, open the connection page (1-2) and create a new connection.

Manual connection:

- Press the button (3) to add new connection.
- Enter the connection name (7).
- Enter the Master IP address (8).
- Press the button (9) to confirm.

Automatic connection:

- Press the button (4) to search new Master units.
- Connect the mobile device to the detected Master unit displayed as New (5).
- Press the button (6) to edit the connection.
- Enter the connection name (7).
- Press the button (9) to confirm.

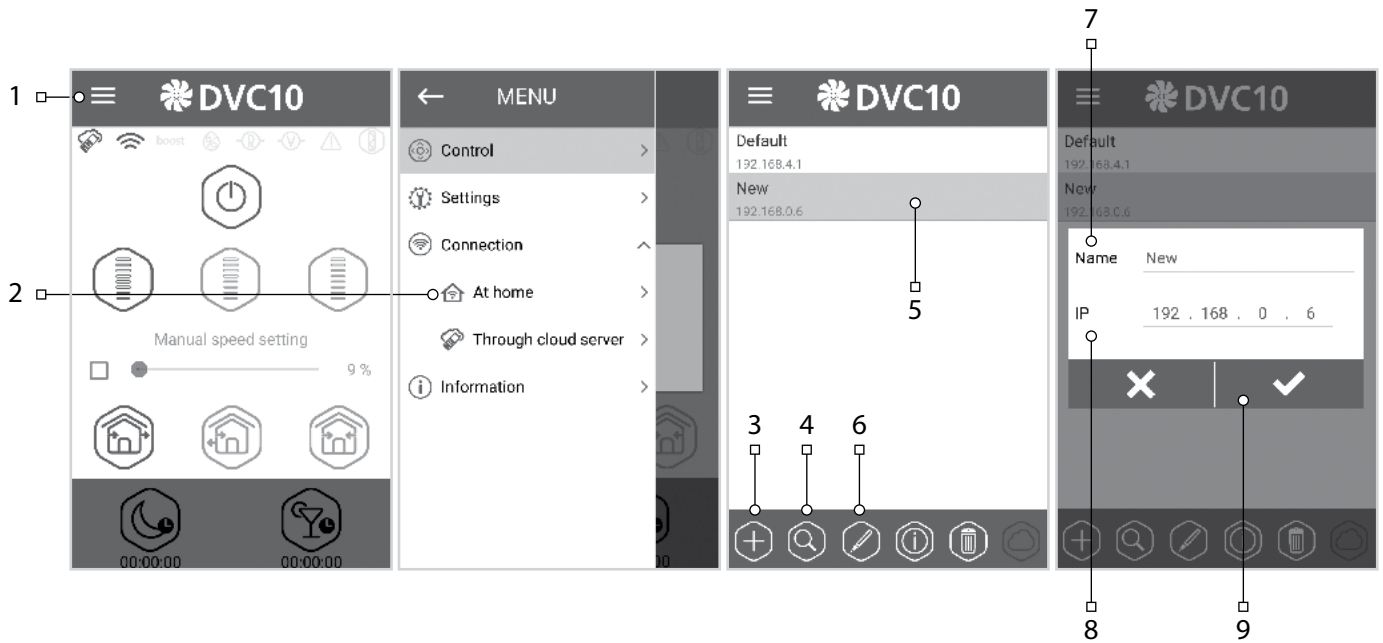

MASTER UNIT DEMO MODE

This mode is for temporary use, i.e. demonstration of the unit operation in a sales shop. No connection to a PC is required. In the demo mode the unit operates in Master mode with its own wireless access point. Only one Slave unit and three mobile devices may be connected to the wireless access point. However it is recommended to connect one mobile device only. Several parallel connected Slave unit in Master demo mode will have the same name and it may result in their conflict.

Master Wi-Fi name: FAN.

Master Wi-Fi password: 11111111.

SLAVE UNIT DEMO MODE

This mode is for temporary use, i.e. demonstration of the unit operation in a sales shop. It is easy to use because of the quick configuration and requires no connection to a PC. The ventilator operates in the Slave mode and is automatically connected to a wireless connection point of the Master unit set for demo mode.

OPERATING THE VENTILATOR THROUGH THE CLOUD SERVER

The Master unit must be set for the operation mode in compliance with the diagram No. 2. By default the control function through the cloud server is off. It must be activated in the following way:

- Connect to the Wi-Fi point of the home router in the system menu of the mobile device.
- Start the application in the mobile device.
- Open the page of the home connection (1-2) in the program menu.
- Select the required connection (3).
- Activate the control function through the could server (4).

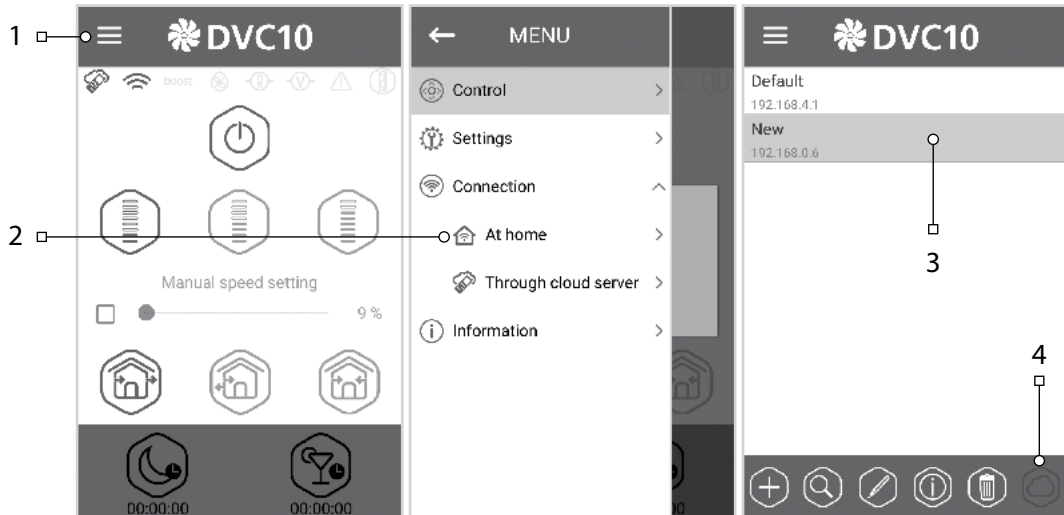

Note: if this function is activated, the home router internet connection troubles may lead to temporary communication losses with the ventilator.

Creating new account:

- In the menu program open page of connection through the cloud server (1-2).
- Enter the account generation menu (3).
- Enter your login (4) and password (5), enter your password again (6) and your Email (7).
- Press the button (8) to confirm.

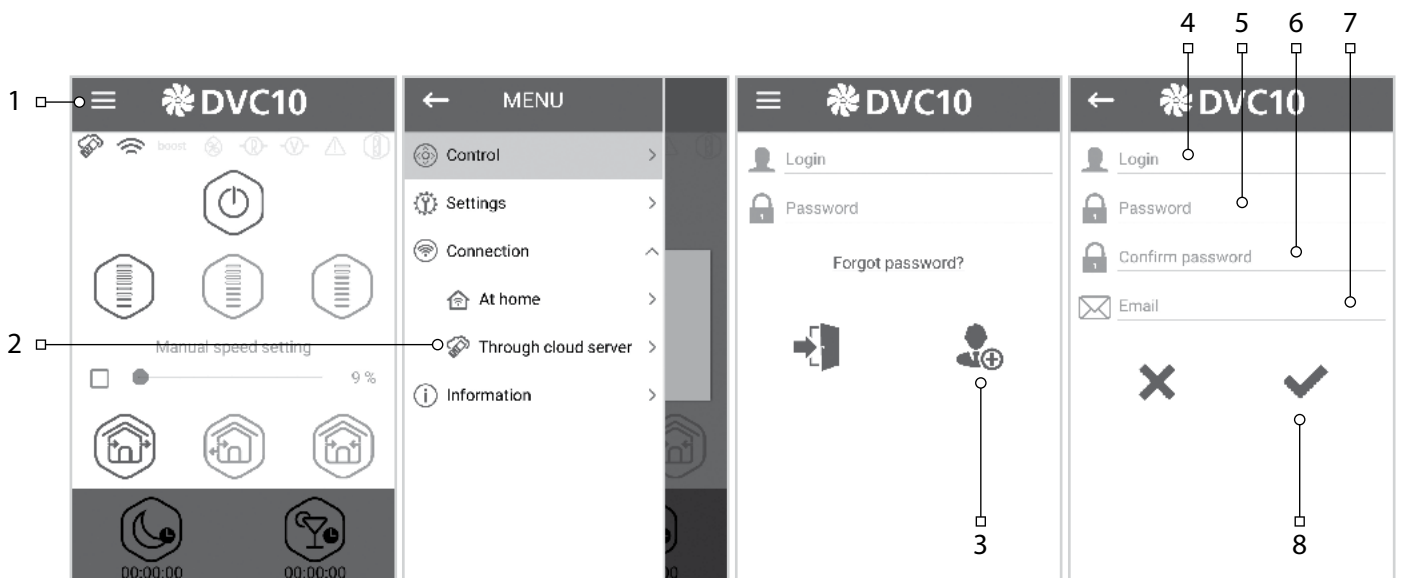

Entering account:

- Enter your login (1) and password (2) on the page of connection through the cloud server.
- Press the button (3) to enter the account.

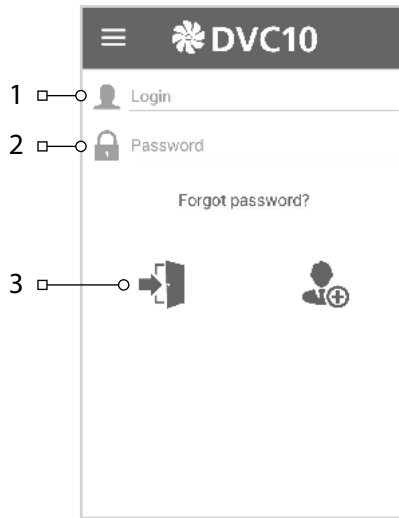

Adding new connection:

- Press the button (1) to add the new connection at the page of connection through the cloud server.
- Enter the connection name (2).
- Enter ID number of the Master unit (3) containing of 16 symbols of the serial number indicated on the circuit board of the Master unit.
- Press the button (4) to confirm.

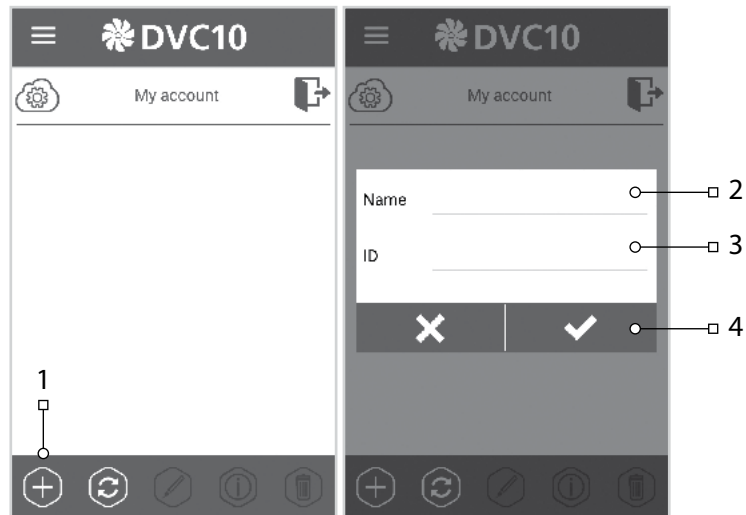

AIR FLOW BLOCKING

Press the front panel to close the air duct. The fan is stopped. The unit functionality remains the same.

To open the air duct pull the front panel through the specially designed recessions. The fan automatically starts operating according to the actual speed setting.

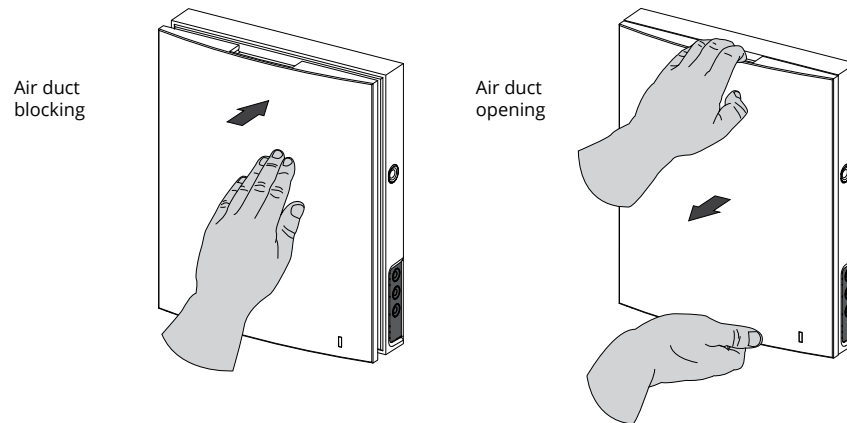

The light operating indicator is located on the front panel. In the night time the indicator glowing goes down.

MAINTENANCE

Maintenance of the ventilator means regular cleaning of the surfaces of dust and cleaning or replacement of the filters.
To enable access to the main units follow the procedure:
turn the unit off using the remote control or with the buttons on the indoor unit.

1. Press the side tabs to release the front part of the indoor unit.

Please make sure the thermal actuator rod is in lower position during re-installation of the front panel. If the thermal actuator rod is up, please wait about 2 minutes until it goes down.

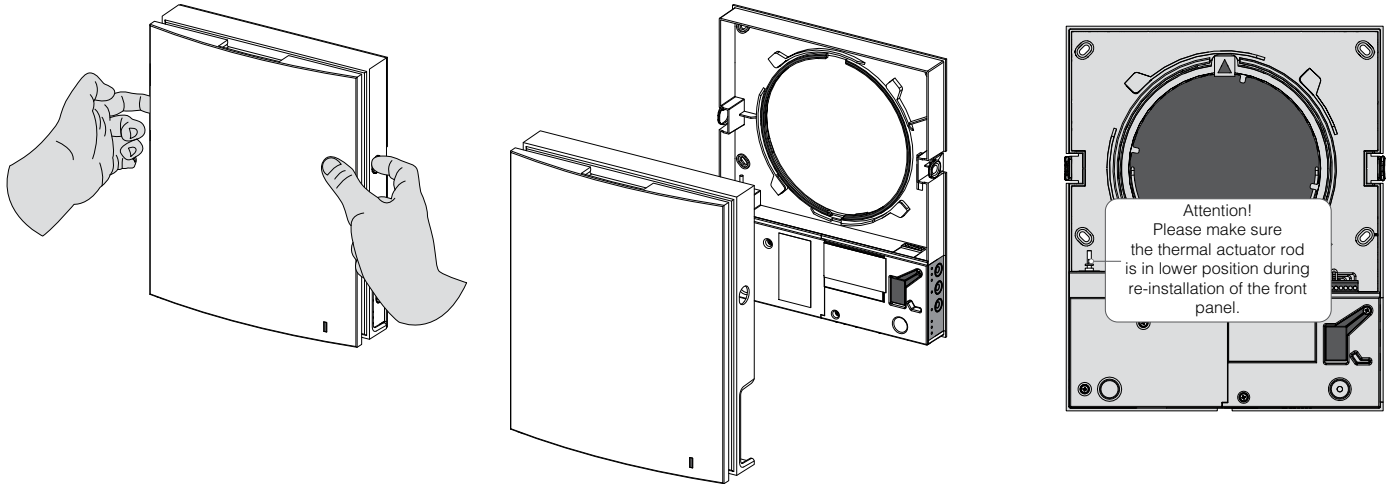

2. Remove the socket connector from the control board. Do not remove the socket connector by pulling the wires. Use a flat screwdriver to uplift it.

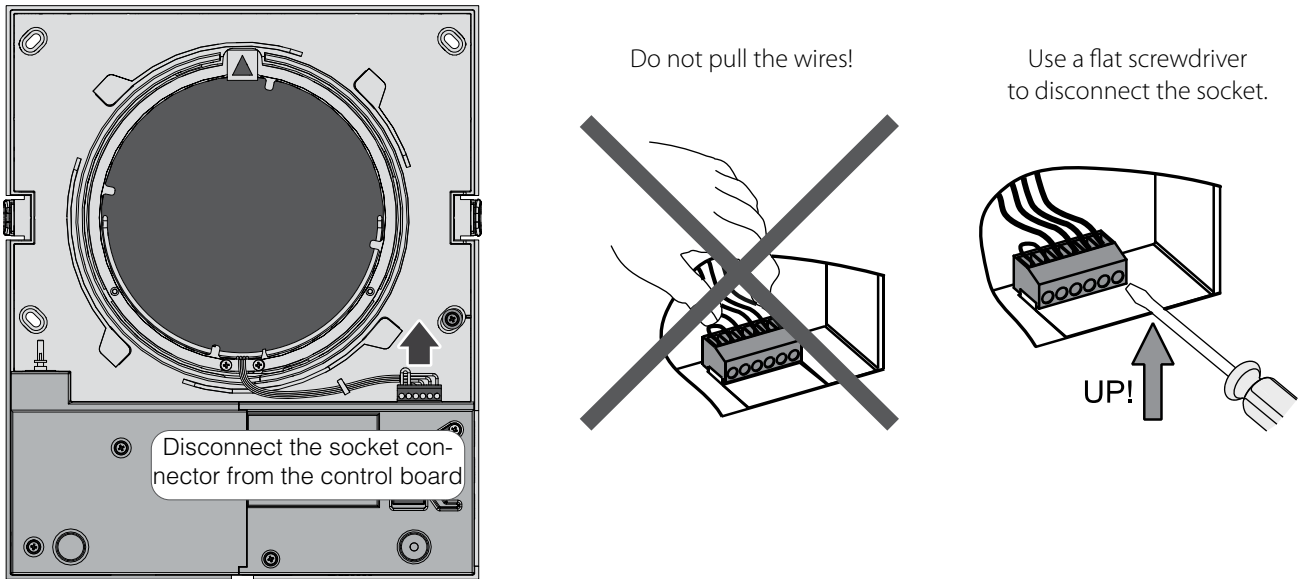

Applicable for DVC 10-50W(L) only.

Never remove the control board! It may cause an alarm! After completion of the servicing and assembly of the ventilator and re-installation of the socket reset an alarm.

3. Pull the band to remove the cartridge from the air duct. Remove the filters from the cartridge.

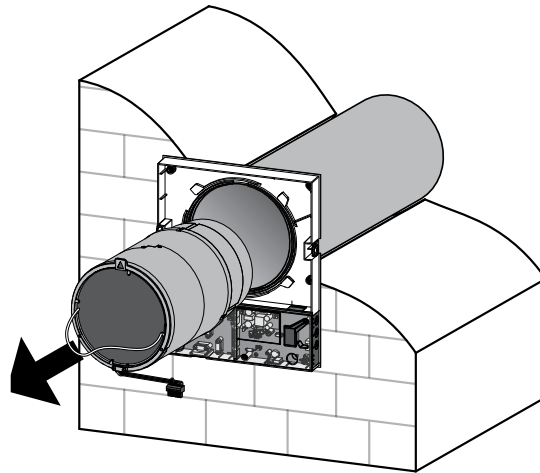

Clean the filters as often as required, but at least 3 times a year.

- Upon elapse of the set time period (factory setting 90 days) the filter replacement indicator (Filter) starts glowing. Resetting of the filter timer settings is performed with the DIP switch on the control board or using the application at your PC, see page 16 or mobile device.
- Wash the filters and let those dry out completely. Install the dry filters in the air duct.
- Vacuum cleaning is allowed.
- The filter rated service life is 3 years.

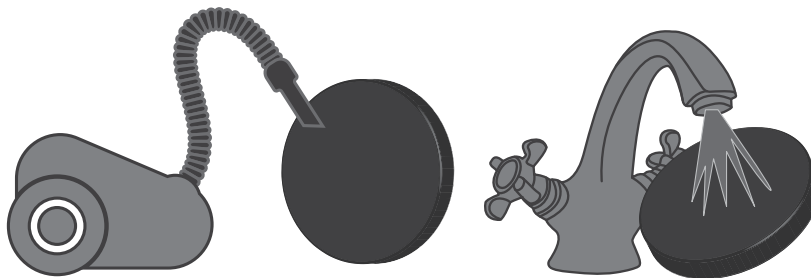

Even regular technical maintenance may not completely prevent dirt accumulation on the regenerator and the fan.

- Clean the regenerator regularly to ensure its high heat recovery efficiency.
- Clean the regenerator with a vacuum cleaner at least once in a year.

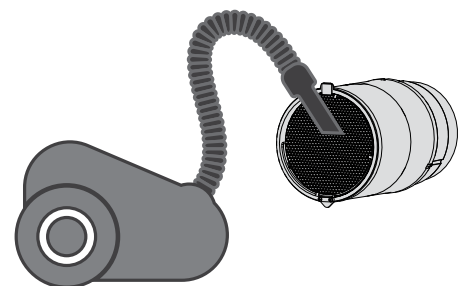

4. Battery replacement in the remote control (as required).

In case of a long operation of the remote control the battery must be replaced.

No response of the unit for pressing the remote control buttons indicates the need to replace the battery.

The battery type is CR2025.

Remove the holder with the battery from the lower part of the remote control.

Then replace the battery and re-install the holder with a new battery in site.

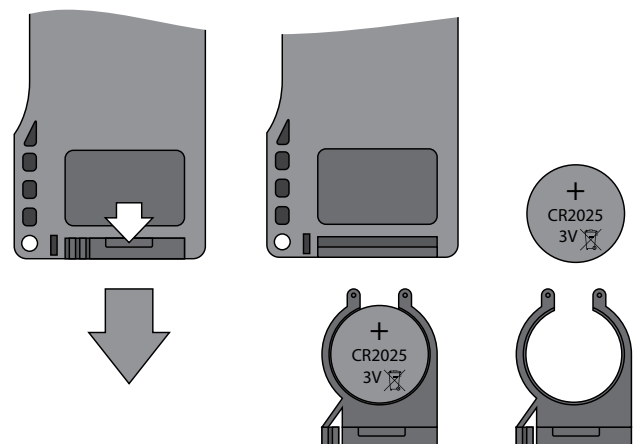

TROUBLESHOOTING

TROUBLES AND TROUBLESHOOTING

Trouble	Possible reasons	Troubleshooting
The fan does not move up during start-up of the unit.	No power supply.	Make sure that the ventilator is properly connected to power mains and troubleshoot a connection error, if required.
	Motor is jammed, the impeller blades are clogged.	Turn the ventilator off. Troubleshoot the motor jam and impeller clogging. Clean the blades. Restart the ventilator.
Circuit breaker tripping during the ventilator start-up.	Overcurrent as a result of short circuit in the electric circuit.	Turn the unit off. Contact the Seller for further information.
Low air flow.	Low set fan speed.	Set higher speed.
	The filter is clogged, the fan or the regenerator is contaminated.	Clean or replace the filter. Clean the fan and the regenerator.
High noise, vibration.	The impeller is soiled.	Clean the impeller.
	Loose screw connection of the unit casing or the outer ventilation hood.	Tighten the screws of the unit or the outer ventilation hood.

STORAGE AND TRANSPORTATION REGULATIONS

Store the unit in the manufacturer's original packing box in a dry ventilated premise at ambient temperatures from +5 °C up to +40 °C.

Storage environment must not contain aggressive vapours and chemical mixtures provoking corrosion, insulation and sealing deformation.

Use suitable hoist machinery for handling and storage operations to prevent possible damage to the unit. Follow the handling requirements applicable for the particular type of cargo.

The unit can be carried in the original packing by any mode of transport provided proper protection against precipitation and mechanical damage.

Avoid sharp blows, scratches or rough handling during loading and unloading.

Do not expose the unit to abrupt temperature drops. It may lead to condensation inside the unit and performance disturbance during the unit start-up.

Prior to the initial power-up after transportation at sub-zero temperatures allow the unit to warm up at room temperature for at least 2 hours.

MANUFACTURER'S WARRANTY

The warranty period is 24 months after the retail sale date provided the user's observance of the transportation, storage, mounting and operation regulations.

Should any malfunctions occur in the course of the unit operation through the Manufacturer's fault during the guaranteed period of operation the user is entitled to elimination of faults by the manufacturer by means of warranty repair at the factory free of charge.

The warranty repair shall include work specific to elimination of faults in the unit operation to ensure its intended use by the user within the guaranteed period of operation.

The faults are eliminated by means of replacement or repair of the unit components or a specific part of such unit component.

The warranty repair does not include:

- Routine technical maintenance;
- Unit installation / dismantling;
- Unit setup.

To benefit from warranty repair the user must provide the unit, the user's manual with the purchase date stamp and the payment document certifying the purchase.

The unit model must comply with the one stated in the user's manual.

Contact the Seller for warranty service.

The manufacturer's warranty does not apply to the following cases:

- User's failure to submit the unit with the entire delivery package as stated in the user's manual including submission with missing component parts previously dismantled by the user.
- Mismatch of the unit model and the brand name with the information stated on the unit packing and in the user's manual.
- User's failure to ensure timely technical maintenance of the unit.
- External damage to the unit casing (excluding external modifications as required for installation) and internal components caused by the user.
- Redesign or engineering changes to the unit.
- Replacement and use of any assemblies, parts and components not approved by the manufacturer.
- Unit misuse.
- User's violation of the unit installation regulations.
- User's violation of the unit control regulations.
- Unit connection to the power mains with a voltage different from the one stated in the user's manual.
- Unit breakdown due to voltage surges in the power mains.
- Discretionary repair of the unit by the user.
- Unit repair by any persons without the manufacturer's authorization.
- Expiration of the unit warranty period.
- User's violation of the unit transportation regulations.
- User's violation of the unit storage regulations.
- Wrongful actions against the unit committed by third parties.
- Unit breakdown due to circumstances of insuperable force (fire, flood, earthquake, war, hostilities of any kind, blockades).
- Missing seals if provided by the user's manual.
- Failure to submit the user's manual with the unit purchase date stamp.
- Missing payment document certifying the unit purchase.



FOLLOWING THE REGULATIONS STIPULATED HEREIN WILL ENSURE A LONG AND TROUBLE-FREE OPERATION OF THE UNIT.

USERS' WARRANTY CLAIMS SHALL BE SUBJECT TO REVIEW ONLY UPON PRESENTATION OF THE UNIT, THE PAYMENT DOCUMENT AND THE USER'S MANUAL WITH THE PURCHASE DATE STAMP.

ACCEPTANCE CERTIFICATE

Unit Type	Heat recovery single-room reversible ventilator
Model	DVC 10-50 _____
Serial Number	
Manufacture Date	
is recognized as serviceable. The product is in compliance with EU norms and standards on low voltage guidelines and electromagnetic compatibility. We hereby declare that the product complies with the provisions of Electromagnetic Council Directive 2014/30/EU, Low Voltage Directive 2014/35/EU and CE-marking Directive 93/68/EEC.	
Quality Inspector's Stamp	

SELLER INFORMATION

Outlet Name	
Address	
Phone Number	
E-mail	
Purchase Date	
This is to certify acceptance of the complete unit delivery with the user's manual. The warranty terms are acknowledged and accepted.	
Customer's Signature	

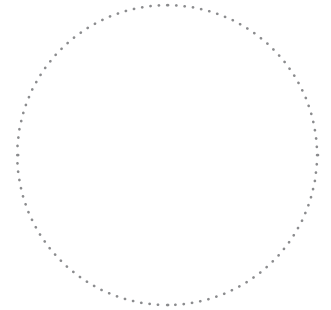

Seller's Stamp

INSTALLATION CERTIFICATE

Heat recovery single-room reversible ventilator DVC 10-50 has been connected to power mains pursuant to the requirements stated in the present user's manual.	
Company Name	
Address	
Phone Number	
Installation Technician's Full Name	
Installation Date:	Signature:
The unit has been installed in accordance with the provisions of all the applicable local and national construction, electrical and technical codes and standards. The unit operates normally as intended by the manufacturer.	
Signature:	

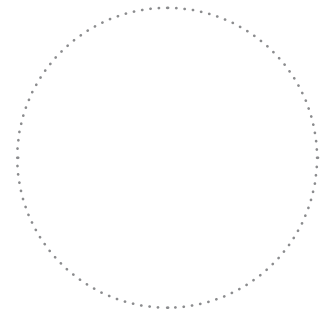

Installation Company Stamp

WARRANTY CARD

Unit Type	Heat recovery single-room reversible ventilator
Model	DVC 10-50 _____
Serial Number	
Manufacture Date	
Purchase Date	
Warranty Period	
Seller	

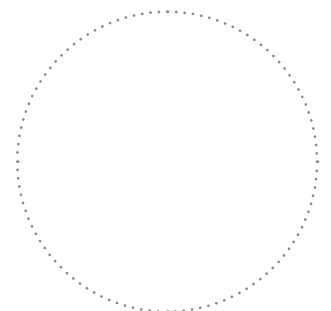

Seller's Stamp

