

Service manual
F1255
Ground source heat pump

Table of Contents

1 Important information	3	Sensors	21
Document information	3	Electronics	22
Safety information	3		
2 The heat pump design	5	6 Troubleshooting	26
General	5	Alarm list	26
Electrical cabinets	7	Troubleshooting guide	38
Cooling section	8	Function check, relays/components	51
3 System description	9		
Principle of operation	9	7 Component replacement	54
System diagram	13	Basic	54
		Main components	57
4 Cooling circuit	15	Circuit board and electronics	68
Outline diagram	15	Temperature sensor	74
Compressor control	15		
Expansion valve	16	8 Technical data	75
		Electrical wiring diagram F1255	75
5 Component description	17	Dimensions and setting-out coordinates	99
Compressor (GQ10)	17	Technical specifications	100
Other components	18		
		Index	106

1 Important information

Document information

This technical manual is a complement to the Installer handbook for F1255, containing:

- Description of functions and component description.
- Information to facilitate fault-tracing.
- Instructions for replacing components.
- Supplementary technical information.

The document applies to heat pumps with software versions from 4665R3 up to and including 7312R3.

The heat pump software version can be found in the info menu (menu 3.1).

Safety information

This manual describes installation and service procedures for implementation by specialists.

This appliance can be used by children aged from 8 years and above and persons with reduced physical, sensory or mental capabilities or lack of experience and knowledge if they have been given supervision or instruction concerning use of the appliance in a safe way and understand the hazards involved. Children shall not play with the appliance. Cleaning and user maintenance shall not be made by children without supervision.

Rights to make any design or technical modifications are reserved.

©NIBE 2016.

Symbols



NOTE

This symbol indicates danger to machine or person.



Caution

This symbol indicates important information about what you should observe when maintaining your installation.



TIP

This symbol indicates tips on how to facilitate using the product.

Marking

The CE marking means that NIBE ensures that the product meets all regulations that are placed on it based on relevant EU directives. The CE mark is obligatory for most products sold in the EU, regardless where they are made.

Serial number

The serial number can be found at the bottom right of the front cover and in the info menu (menu 3.1).

You can also find the serial number on the type plate PF1, for location see the section for the Heat pump design in the installer manual.

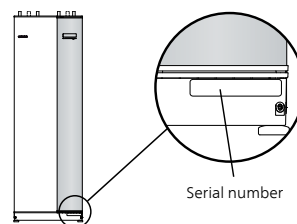

Caution

Always give the product's serial number (14 digits) when reporting a fault.

Contact information

- AT KNV Energietechnik GmbH**, Gahberggasse 11, 4861 Schörfling
Tel: +43 (0)7662 8963-0 Fax: +43 (0)7662 8963-44 E-mail: mail@knv.at www.knv.at
- CH NIBE Wärmetechnik c/o ait Schweiz AG**, Industriepark, CH-6246 Altishofen
Tel: (52) 647 00 30 Fax: (52) 647 00 31 E-mail: info@nibe.ch www.nibe.ch
- CZ Druzstevni zavody Drazice s.r.o.**, Drazice 69, CZ - 294 71 Benatky nad Jizerou
Tel: +420 326 373 801 Fax: +420 326 373 803 E-mail: nibe@nibe.cz www.nibe.cz
- DE NIBE Systemtechnik GmbH**, Am Reiherpfahl 3, 29223 Celle
Tel: 05141/7546-0 Fax: 05141/7546-99 E-mail: info@nibe.de www.nibe.de
- DK Vølund Varmeteknik A/S**, Member of the Nibe Group, Brogårdsvej 7, 6920 Videbæk
Tel: 97 17 20 33 Fax: 97 17 29 33 E-mail: info@volundvt.dk www.volundvt.dk
- FI NIBE Energy Systems OY**, Juurakkotie 3, 01510 Vantaa
Puh: 09-274 697 0 Fax: 09-274 697 40 E-mail: info@nibe.fi www.nibe.fi
- FR NIBE Energy Systems France Sarl**, Zone industrielle RD 28, Rue du Pou du Ciel, 01600 Reyrieux
Tel : 04 74 00 92 92 Fax : 04 74 00 42 00 E-mail: info@nibe.fr www.nibe.fr
- GB NIBE Energy Systems Ltd**, 3C Broom Business Park, Bridge Way, Chesterfield S41 9QG
Tel: 0845 095 1200 Fax: 0845 095 1201 E-mail: info@nibe.co.uk www.nibe.co.uk
- NL NIBE Energietechnik B.V.**, Postbus 634, NL 4900 AP Oosterhout
Tel: 0168 477722 Fax: 0168 476998 E-mail: info@nibenl.nl www.nibenl.nl
- NO ABK AS**, Brobekkveien 80, 0582 Oslo, Postadresse: Postboks 64 Vollebakk, 0516 Oslo
Tel. sentralbord: +47 23 17 05 20 E-mail: post@abkklima.no www.nibeenergysystems.no
- PL NIBE-BIAWAR Sp. z o. o.** Aleja Jana Pawła II 57, 15-703 BIAŁYSTOK
Tel: 085 662 84 90 Fax: 085 662 84 14 E-mail: sekretariat@biawar.com.pl www.biawar.com.pl
- RU © "EVAN" 17**, per. Boynovskiy, Nizhny Novgorod
Tel./fax +7 831 419 57 06 E-mail: info@evan.ru www.nibe-ivan.ru
- SE NIBE AB Sweden**, Box 14, Hannabadsvägen 5, SE-285 21 Markaryd
Tel: +46-(0)433-73 000 Fax: +46-(0)433-73 190 E-mail: info@nibe.se www.nibe.se

For countries not mention in this list, please contact Nibe Sweden or check www.nibe.eu for more information.

2 The heat pump design

General

Front view

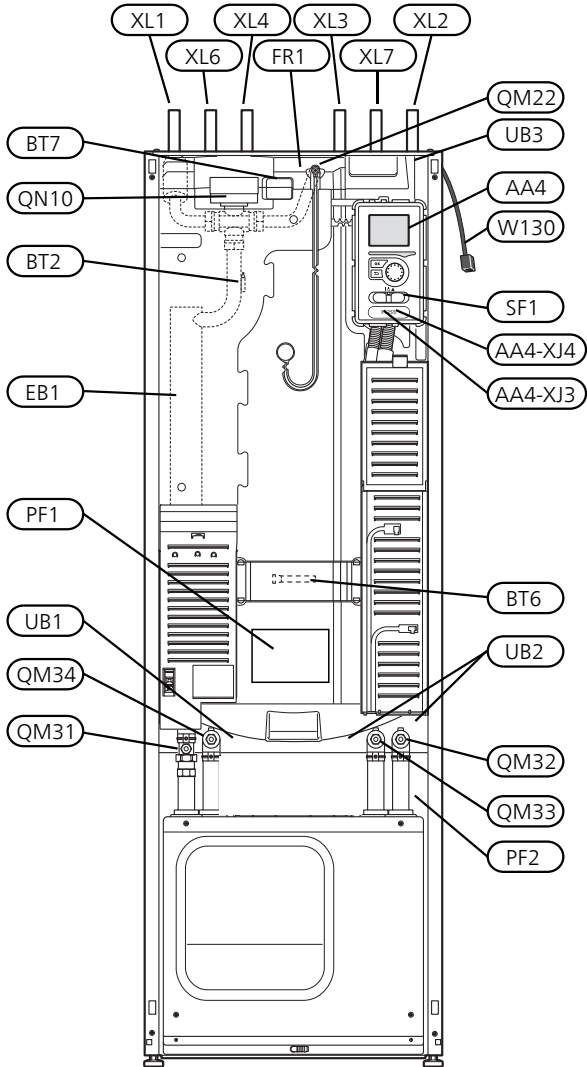

View from behind

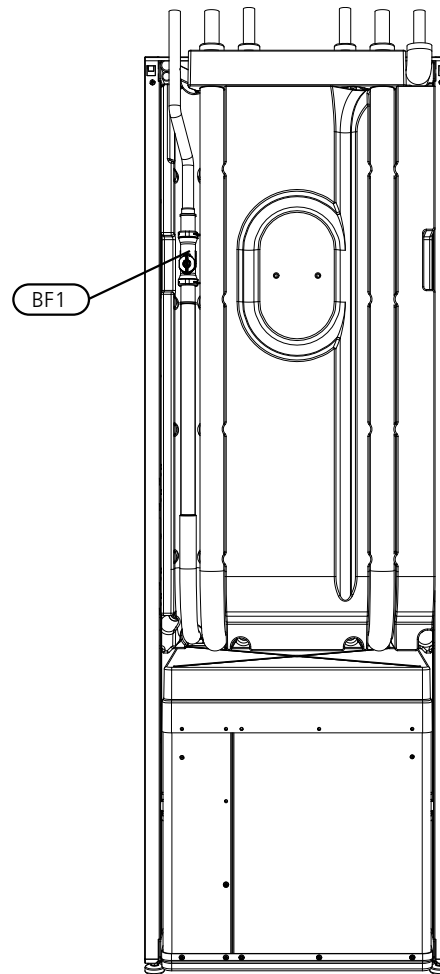

Top view

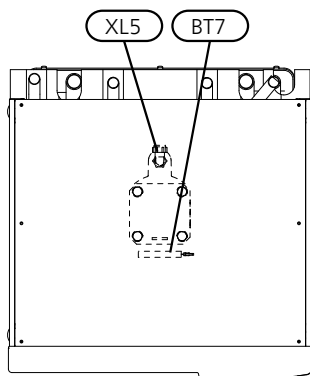

Pipe connections

XL 1	Connection, heating medium flow
XL 2	Connection, heating medium return
XL 3	Connection, cold water
XL 4	Connection, hot water
XL 5	Connection, HWC*
XL 6	Connection, brine in
XL 7	Connection, brine out

* Only applies to enamelled or stainless steel vessels.

HVAC components

QM 22	Venting, coil
QM 31	Shut-off valve, heating medium flow
QM 32	Shut off valve, heating medium return
QM 33	Shut off valve, brine out
QM 34	Shut-off valve, brine in
QN 10	Shuttle valve, climate system/water heater

Sensors etc.

BF 1	Flow meter (EU models)
BT 1	Outdoor temperature sensor (externally mounted)
BT 2	Temperature sensors, heating medium flow
BT 6	Temperature sensor, hot water charging
BT 7	Temperature sensor, hot water top

Electrical components

AA 4	Display unit
	AA4-XJ3 USB outlet (no function)
	AA4-XJ4 Service outlet (No function)
EB 1	Immersion heater
FR 1	Sacrificial anode*
SF 1	Switch
W130	Network cable for NIBE Uplink™

* Only heat pump with enamelled vessel.

Miscellaneous

PF 1	Type plate, serial no.
PF 2	Type plate, cooling section
UB 1	Cable gland, incoming electricity
UB 2	Cable gland
UB 3	Cable gland, rear side, sensor

Designations in component locations according to standard IEC 81346-1 and 81346-2.

Electrical cabinets

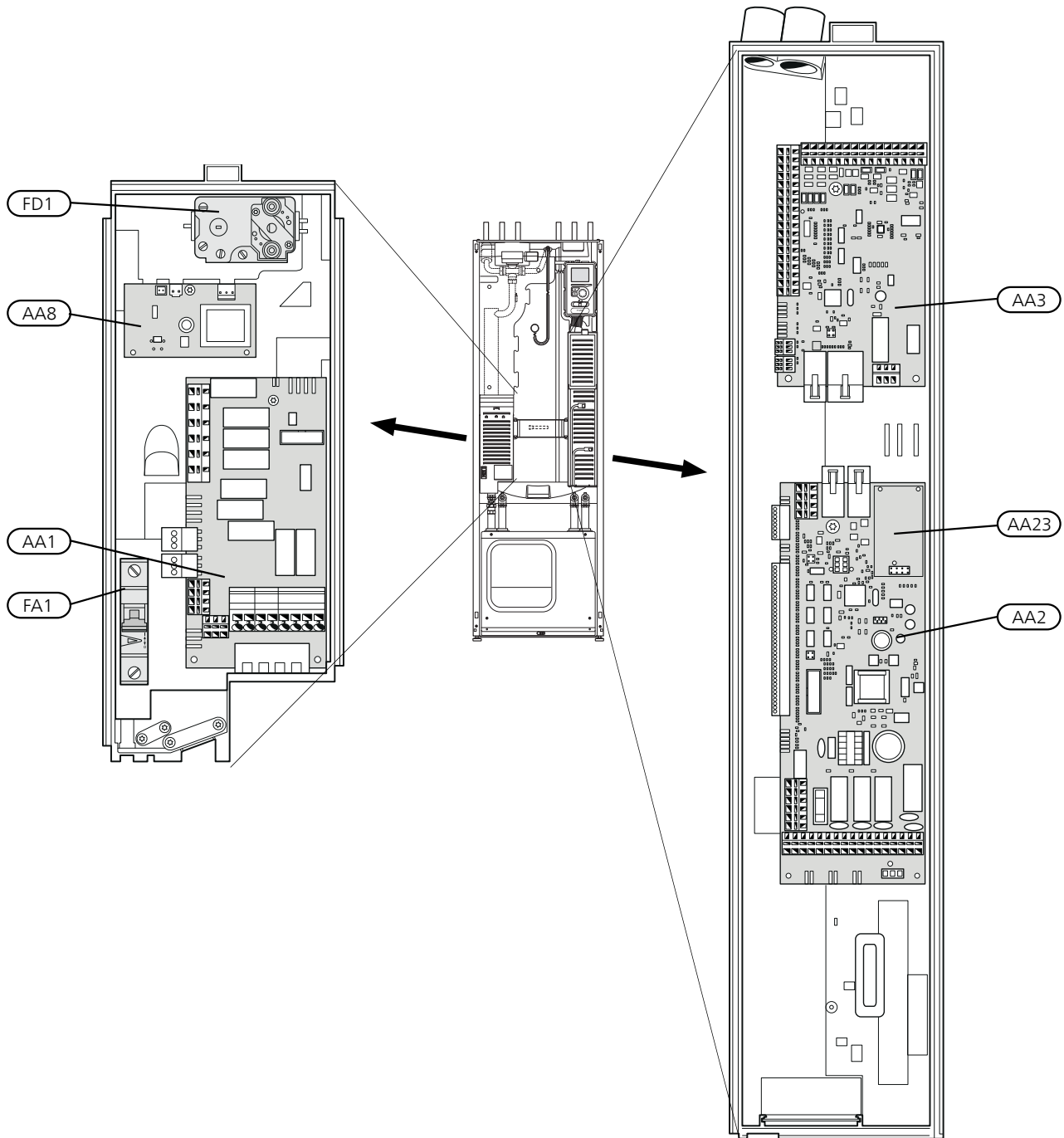

Electrical components

- AA 1 Immersion heater card
- AA 2 Base card
- AA 3 Input circuit board
- AA 8 Sacrificial anode card*
- AA23 Communication board
- FA 1 Miniature circuit-breaker
- FD 1 Temperature limiter/Emergency mode thermostat

* Only heat pump with enamelled vessel.

Designations in component locations according to standard IEC 81346-1 and 81346-2.

Cooling section

F1255-6

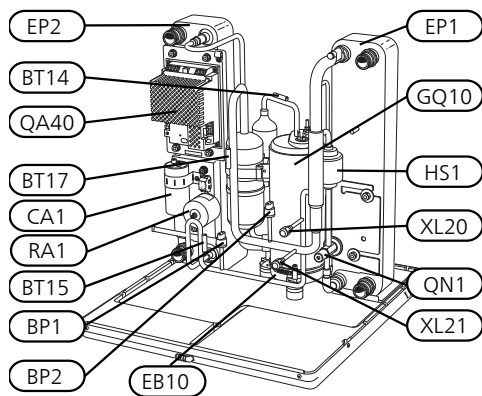
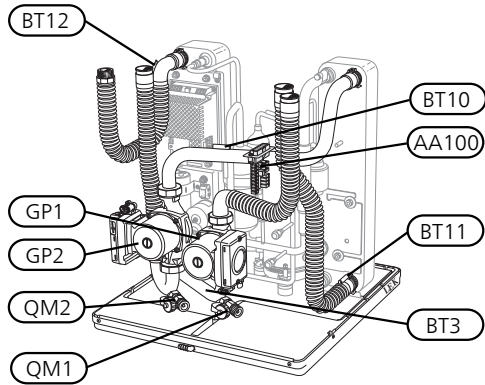

F1255-16

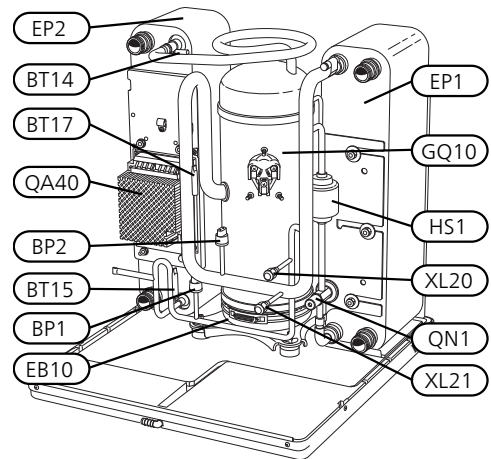
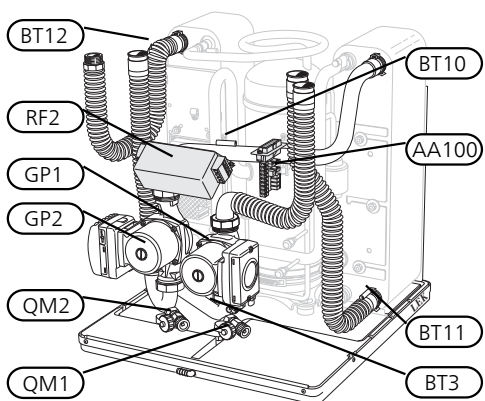

Pipe connections

- XL 20 Service connection, high pressure
- XL 21 Service connection, low pressure

HVAC components

- GP 1 Circulation pump
- GP 2 Brine pump
- QM 1 Drainage, climate system
- QM 2 Draining, brine side

Sensors etc.

- BP 1 High pressure pressostat
- BP 2 Low pressure pressostat
- BT 3 Temperature sensors, heating medium return
- BT 10 Temperature sensor, brine in
- BT 11 Temperature sensor, brine out
- BT 12 Temperature sensor, condenser supply line
- BT 14 Temperature sensor, hot gas
- BT 15 Temperature sensor, fluid pipe
- BT 17 Temperature sensor, suction gas
- BT 29 Temperature sensor, compressor

Electrical components

- AA 100 Joint card
- EB 10 Compressor heater
- RF 2 EMC-filter
- QA 40 Inverter

Cooling components

- EP 1 Evaporator
- EP 2 Condenser
- GQ 10 Compressor
- HS 1 Drying filter
- QN 1 Expansion valve

Designations in component locations according to standard IEC 81346-1 and 81346-2.

3 System description

Principle of operation

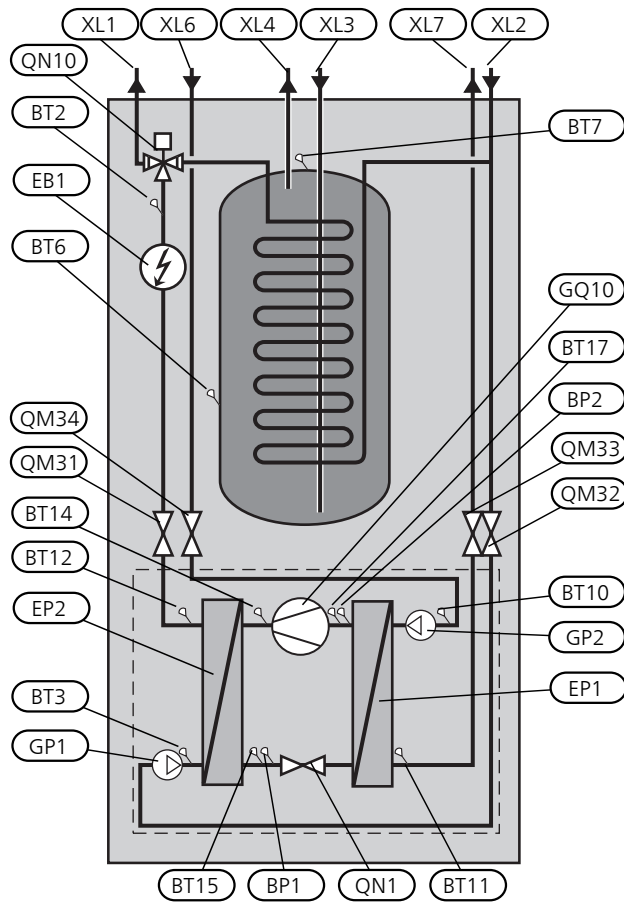

List of components

Pipe connections

- XL 1 Connection, heating medium flow
- XL 2 Connection, heating medium return
- XL 3 Connection, cold water
- XL 4 Connection, hot water
- XL 6 Connection, brine in
- XL 7 Connection, brine out

Cooling components

- EP 1 Evaporator
- EP 2 Condenser
- GQ 10 Compressor
- QN 1 Expansion valve

HVAC components

- GP 1 Circulation pump
- GP 2 Brine pump
- QM 31 Shut-off valve, heating medium flow
- QM 32 Shut off valve, heating medium return
- QM 33 Shut off valve, brine out
- QM 34 Shut-off valve, brine in
- QN 10 Shuttle valve, climate system/water heater

Sensors etc.

Internal

	Name	Location	Function
BP1	High pressure pressostat	On the liquid line.	Protects the compressor against pressures that are too high.
BP2	Low pressure pressostat	On suction gas line.	Protects the compressor against pressures that are too low.
BT1*	Outside sensor	Outdoor, shaded location on north side of the house.	Set point values for heating and cooling demand calculation. Operating mode change.
BT2	Flow pipe	On supply line after immersion heater (EB1).	Calculation of DM. If BT25 is installed, only view.
BT3	Return pipe	On return line between circulation pump (GP1) and condenser (EP2).	Stopping the compressor at high temperature.
BT6	Hot water, charging	On water heater lower section.	Stop and start of hot water charging.
BT7	Hot water, top	At water heater peak.	View.
BT10	Brine in	On incoming brine line before circulation pump (GP2).	View. Stops compressor at high temperature. Controls brine pump speed together with BT11
BT11	Brine out	On outgoing brine line after evaporator (EP1).	Stopping the compressor at low temperature. Controls brine pump speed together with BT10
BT12	Condenser flow line	On supply line between condenser (EP2) and immersion heater (EB1).	Stopping the compressor at high temperature.
BT14	Discharge	On hot gas line after compressor (GQ10).	Stopping the compressor at high temperature.
BT15	Fluid pipe	On the liquid line after the condenser (EP2).	View.
BT17	Suction gas	On suction gas line before the compressor (GQ10).	View.
BT25*	External flow line	Externally on the flow line to the heating system.	Calculation of DM. Actual value for additional shunt.
BT50*	Room sensor	In suitable indoor location.	Correction of the indoor temperature.

* Externally mounted (not included in outline diagram).

External

	Name	Location	Function
CL11-BT51	Pool sensor	On pool water pipe in heat exchanger.	Stop and start of pool charging.
EP30-BT53	Solar panel sensor	On the solar panel	In relation to BT54, stop and start of solar charging.
EP30-BT54	Solar tank, bottom	On solar tank bottom	In relation to BT53, stop and start of solar charging.
EM1-BT52	Boiler sensor	In additional heat boiler	Closes additional heat mixing valve when boiler is cold.
EQ1-BT64	Flow line, cooling	On flow line, cooling	Actual value for mixing valve cooling (EQ1-QN18)
EQ1-BT65	Return line, cooling	On return line, cooling	View
EP21-BT2	Flow line, extra climate system	On flow line to extra climate system 2.	Actual value for mixing valve, climate system 2.
EP21-BT3	Return line, extra climate system	On return line from extra climate system 2.	View.
EP22-BT2	Flow line, extra climate system	On flow line to extra climate system 3.	Actual value for mixing valve, climate system 3.
EP22-BT3	Return line, extra climate system	On return line from extra climate system 3.	View.
EP23-BT2	Flow line, extra climate system	On flow line to extra climate system 4.	Actual value for mixing valve, climate system 4.
EP23-BT3	Return line, extra climate system	On return line from extra climate system 4.	View.
EP24-BT2	Flow line, extra climate system	On supply line to extra climate system 5.	Actual value for shunt valve, climate system 5.
EP24-BT3	Return line, extra climate system	On return line from extra climate system 5.	View
EP25-BT2	Flow line, extra climate system	On supply line to extra climate system 6.	Actual value for shunt valve, climate system 6.
EP25-BT3	Return line, extra climate system	On return line from extra climate system 6.	View
EP26-BT2	Flow line, extra climate system	On supply line to extra climate system 7.	Actual value for shunt valve, climate system 7.
EP26-BT3	Return line, extra climate system	On return line from extra climate system 7.	View
EP27-BT2	Flow line, extra climate system	On supply line to extra climate system 8.	Actual value for shunt valve, climate system 8.
EP27-BT3	Return line, extra climate system	On return line from extra climate system 8.	View
AZ1-BT20	Exhaust air	In exhaust air in FLM.	View.

	Name	Location	Function
AZ1-BT21	Extract air	In extract air in FLM.	Controls defrosting
AZ1-BT26	Collector in	On incoming collector line in FLM.	View.
AZ1-BT27	Collector out	On outgoing collector line in FLM.	View.

System diagram

Heating

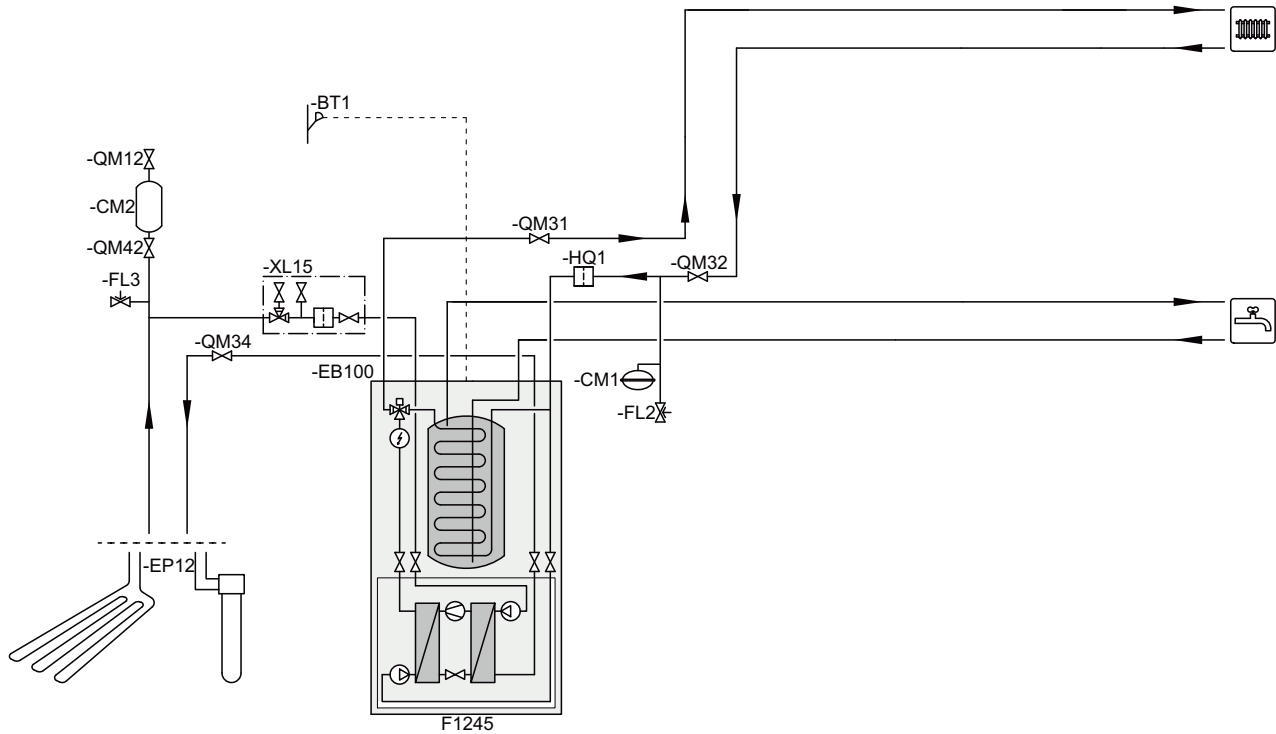

Labels according to IEC 61346-2

Function

The heat pump prioritises hot water charging. The circulation pump GP1 runs at a calculated speed. When the water heater is fully charged QN10 switches to the heating system. The heat pump works to a calculated set point value on the supply line. If the compressor cannot meet the whole heating requirement, electric heat is shunted in as necessary.



TIP

More system principles are on www.nibe.eu.
Refer to the Installer manual for description of possible docking alternatives.

Installation requirements

Heating medium side

		6kW	16kW
Max system pressure	Bar	4,5	
Min. flow** (50 Hz)	l/s	0.06	0.15
Nominal flow (50 Hz)	l/s	0.08	0.22
Max. recommended flow, (50 Hz)	l/s	0.10	0.30
Max. external available pressure at nominal flow*** (50 Hz)	kPa	69	71
Min/max temperature	°C		See diagram page 104.

* min volume refers to circulating flow

** overflow valve must be used if min flow cannot be guaranteed

*** external circulation pump must be used when the pressure drop in the system is greater than the available external pressure. In such cases, a bypass line with non-return valve must be installed.

Brine side

		6kW	16kW
Max system pressure	Bar	4,5	
Min. flow (50 Hz)	l/s	0.13	0.36
Nominal flow (50 Hz)	l/s	0,18	0.51
Max. external available pressure at nominal flow (50 Hz)	kPa	64	95
Max/min incoming temperature	°C	See diagram page 105.	

4 Cooling circuit

Outline diagram

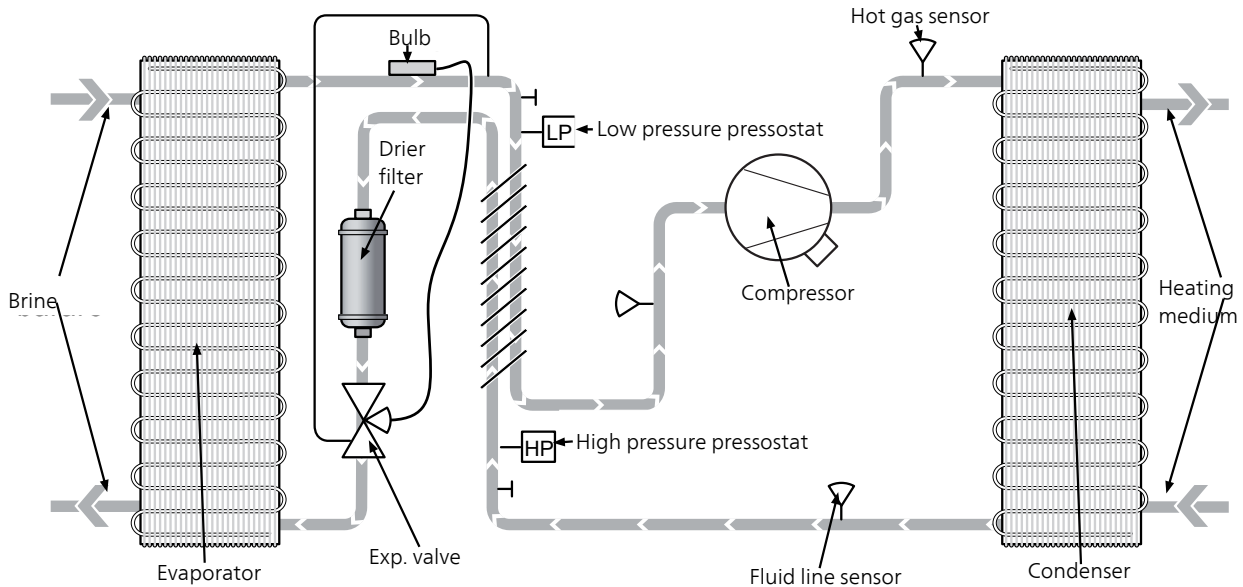

Compressor control

blockFreq

- 2x selectable blockFreq (5.1.24) with blocking range 3-50Hz.

Model	Factory settings	Remarks
6Kw	91-120Hz	
16Kw	-	

Hot gas limit BT 14

	6Kw	16Kw
The compressor is stopped. Alarm 55	120°C	135C
Reduces the compressor's frequency by 5 Hz/min.	110°C	130°C
Increase of compressor frequency blocked > Return to free control of the compressor <	107°C	125°C

High pressure pressostat

Stop with automatic restart:

- The compressor stops when the pressure is 32 bar, and restarts automatically when the pressure is below 25 bar.

Stop with manual restart missing.

Compressor	Stop	Reconnection differential
16 kW	32 bar	-7 bar
6 kW	32 bar	-7 bar

Low pressure pressostat

Stop with manual restart:

- The compressor stops when the pressure is below 1.5 bar, and can restart when the pressure is above 3 bar.

Compressor	Stop	Reconnection differential
16 kW	1.5 bar	1.5 bar
6 kW	1.5 bar	1.5 bar

The function is blocked for 1 minute after switching between charging type (HW, heating, pool).

Working area

See diagram page 104.

Time conditions

Minimum time between stop and start is 5 min.

Minimum time from start to stop to start is 20 min.

Compressor heater

The compressor heater is active when relay (K4) on the base card is in unaffected mode.

When the compressor is inactive the compressor heater is always active.

Expansion valve

Check that overheating occurs by measuring the vapour temperature with a manometer and the suction gas temperature with a service thermometer. The suction gas temperature is measured on the suction pipe at the entrance to the compressor.

Overheating is shown in the table below and must be checked when the compressor frequency is 30 - 90 Hz and when the temperature of the heating medium supply is 30 - 55 °C and brine in is -5 - +10 °C.

Brine temperatures higher than +10 °C in combination with high compressor frequency (Hz) can cause greater overheating.

F1255	superheat
6 kW	4 - 8 °C
16 kW	4 - 8 °C

5 Component description

Compressor (GQ10)

3 x 230 V, 1 x 230 V, 3 x 400 V

Size (kW)	Type	Resistance range (Ω at 20 °C +/- 10 %)		
		T1-T3[C-R]	T1-T2[C-S]	T2-T3[S-R]
6	Rotation	0.72	0.72	0.72

3 x 400 V

Size (kW)	Type	Resistance range (Ω at 20 °C +/- 10 %)		
		T1-T3[C-R]	T1-T2[C-S]	T2-T3[S-R]
16	Piston	5.19	5.19	5.19

Other components

Component	Description									
Immersion heater (EB1)	<p>F1255-16, 3x400 V</p> <p>White coil (1/3 kW), internal resistance: 55 ohm</p> <p>Brown coils (3 x 2 kW), internal resistance: 27 ohm</p>									
	<p>F1255-6, 1 x 230 V, 3 x 230 V, 3 x 400 V</p> <p>White coil (2 kW), internal resistance 27 ohm</p> <p>Red coil:</p> <ul style="list-style-type: none"> ▪ 1 x 230 V: (1 kW), internal resistance 55 ohm ▪ 3 X 230 V: (1 kW), internal resistance 55 ohm ▪ 3 x 400 V: (3 kW), internal resistance 55 ohm <p>Brown coil (1 kW), internal resistance 55 ohm</p> <p>Black coil (0.5 kW), internal resistance 110 ohm</p>									
Reversing valve (QN10)	<p>Actuator motor: 7 VA, 230/24 VAC, 50 Hz, IP 40. Running time approx 8 seconds</p> <p>Max. operating pressure: 1.0 MPa</p> <p>Operating temperature: 5 - 80 °C (90 °C briefly)</p> <div style="text-align: center;"> </div> <table border="1" style="width: 100%; margin-top: 10px;"> <thead> <tr> <th></th> <th>F1255-6</th> <th>F1255-16</th> </tr> </thead> <tbody> <tr> <td>A</td> <td>Ø22 mm</td> <td>Ø28 mm</td> </tr> <tr> <td>B</td> <td>Ø22 mm</td> <td>Ø28 mm</td> </tr> </tbody> </table>		F1255-6	F1255-16	A	Ø22 mm	Ø28 mm	B	Ø22 mm	Ø28 mm
	F1255-6	F1255-16								
A	Ø22 mm	Ø28 mm								
B	Ø22 mm	Ø28 mm								

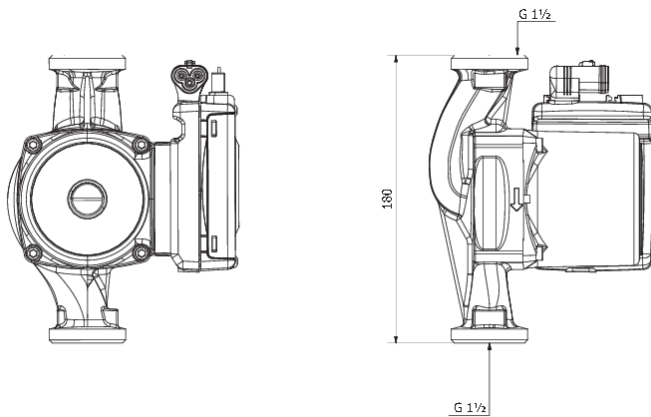
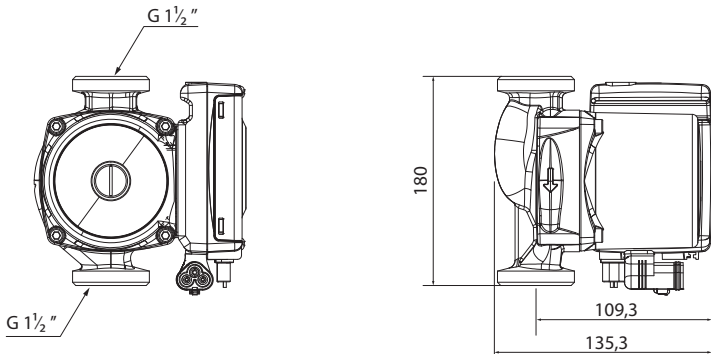
Component	Description
Heating medium pump (GP1)	<p>F1255-16 UPM GEO 25-85. Operating voltage 1x230 V, max 70 W Control signal: PWM 0 - 10 V DC (max-min speed) Max flow: 8.5 m³/h Max lift height: 5 m.</p>  <p>F1255-6 UPM2 25-70. Operating voltage 1x230 V, max 63 W Control signal: PWM 0 - 10 V DC (max-min speed) Max flow: 5 m³/h Max lift height: 7 m.</p> 

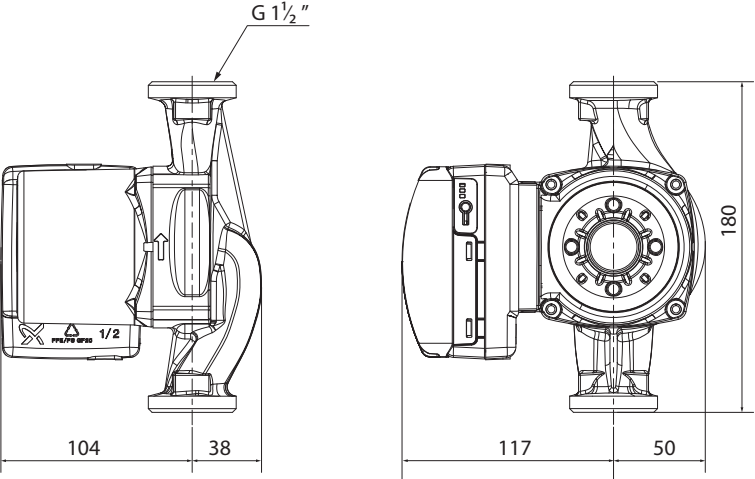
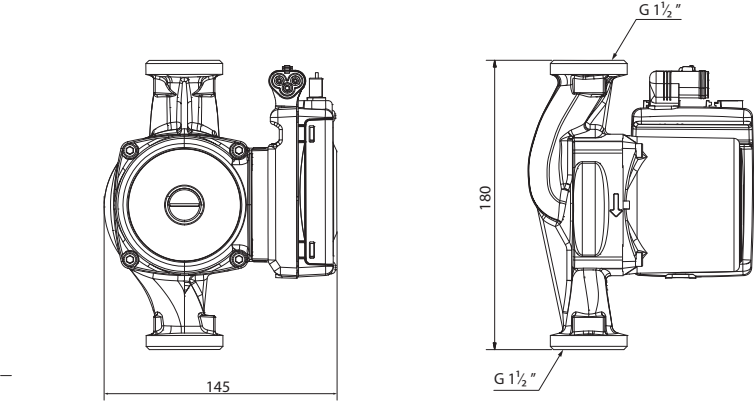
Component	Description
<p>Brine pump (GP2)</p>	<p>F1255-16 UPM XL –Geo 25-125. Operating voltage 1*230 V, max 180 W Control signal: PWM 0 - 10 V DC (max-min speed)</p>  <p>F1255-6 UPM GEO 25-85. Operating voltage 1x230 V, max 70 W Control signal: PWM 0 - 10 V DC (max-min speed) Max flow: 8.5 m³/h Max lift height: 5 m.</p> 
<p>High pressure switch (BP1)</p>	<p>Breaking value: 32 bar Reconnection differential: -7 bar</p>
<p>Low pressure switch (BP2)</p>	<p>Breaking value: 1.5 bar Reconnection differential: 1.5 bar</p>
<p>Compressor heater</p>	<p>Output (5-10): 30 W</p>

Sensors

Temperature sensor data

Temperature (°C)	Resistance (kOhm)	Voltage (VDC)
-40	351.0	3.256
-35	251.6	3.240
-30	182.5	3.218
-25	133.8	3.189
-20	99.22	3.150
-15	74.32	3.105
-10	56.20	3.047
-5	42.89	2.976
0	33.02	2.889
5	25.61	2.789
10	20.02	2.673
15	15.77	2.541
20	12.51	2.399
25	10.00	2.245
30	8.045	2.083
35	6.514	1.916
40	5.306	1.752
45	4.348	1.587
50	3.583	1.426
55	2.968	1.278
60	2.467	1.136
65	2.068	1.007
70	1.739	0.891
75	1.469	0.785
80	1.246	0.691
85	1.061	0.607
90	0.908	0.533
95	0.779	0.469
100	0.672	0.414
120	0.380	0.250
150	0.180	0.120

Electronics

Immersion heater card (AA1)

LED	Indication
K1 - K10: Orange	A steady light means that the relevant relay is engaged.

Out-put	Function		
	1x230 V	3x230 V	3x400 V
K1	Supply L1	Supply L1	Supply L1
K2	Supply L1	Supply L2	Supply L2
K3	Supply L1	Supply L2	Supply L3
K4	Immersion heater 0.5 kW	Supply L3	1255-6: Immersion heater 0.5 kW 1255-16: 2 kW
K5	No function	Supply L3	1255-6: Immersion heater 3 kW on K9 1255-16: No function
K6	Immersion heater 1 kW	Immersion heater 2 kW	1255-6: Immersion heater 1kW 1255-16: Immersion heater 2 kW
K7	No function	Immersion heater 0.5 kW	1255-6: No function 1255-16: Immersion heater 3 kW on K9
K8	Immersion heater 2 kW	No function	1255-6: Immersion heater 2 kW 1255-16: Immersion heater 2 kW
K9	Immersion heater 1 kW	Immersion heater 1 kW	1255-6: Immersion heater 3 kW on K5 1255-16: Immersion heater 1/3 kW

Out-put	Function		
K10		Immersion heater 1kW	

Base card (AA2)

LED	Indication
Power: Green	A steady light means that 12 V is OK.
Run: Green	Flashing once/sec. Indicates that the processor is OK.
Com: Green	Flashes irregularly during communication.
PWM1: Orange	Continuous light during active output.
PWM2: Orange	Continuous light during active output.
K1 - K4: Orange	A steady light means that the relevant relay is engaged.

Output	Function
PWM1	Control signal HM pump (GP1)
PWM2	Control signal brine pump (GP2)
K1	Reversing valve (QN10)
K2	Brine pump (GP2)
K3	HM pump (GP1)
K4	Compressor heater (EB10) (inverted signal)

Input circuit board (AA3)

LED	Indication
Power: Green	A steady light means that 12V is OK.
Run: Green	Flashing once/sec. Indicates that the processor is OK.
Com: Green	Flashes irregularly during communication.
PWM1: Orange	Continuous light during active output.
PWM2: Orange	Continuous light during active output.
K1: Orange	A steady light means that the relay is engaged.

Communication board (AA123)

LED	Indication
INV: Lights green	A steady light indicates supply from the inverter.
PWR: Lights green	A steady light indicates voltage from the AA2 Base card.
COM: Flashes green	Irregular flashing indicates communication with the inverter.

Inverter

The inverter's Status-LED indicates acc. to the table below:

Status LED	Status
Green, steady	The compressor stopped, OK
Green, flashing	The compressor stopped, OK
Orange, steady	Compressor is operational, OK
Red, steady	Alarm
Red, flashing	Broken circuit on terminal block X4

The inverter's power LED lights orange continuously when the inverter is powered. (Only applies to 16kW).

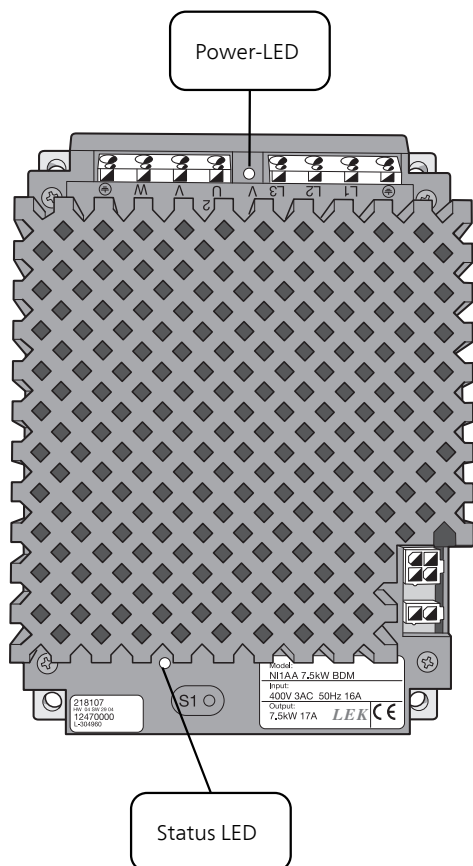

MODBUS 40

LED	Indication
BATT	No function.
RUN	No function.
COM1	Flashes during communication with the heat pump.
LED 4 (-)	No function.
LEV	No function.
COM2	No active communication between Modbus 40 and "external control".
SYNC	No function.
VCC	A steady light means that supply voltage is OK.

SMS 40

LED	Indication
BATT	A steady light if voltage in the battery is above 0 V. Out if the battery is discharged or if no battery is installed.
RUN	No function.
COM1	Flashes during communication with heat pump and at start-up.
LED 4 (-)	A steady light that indicates that 12V is OK.
LEV	Steady light when the GSM signal is OK. Out if the GSM signal is too low.
COM2	Flashes during communication with the GSM modem.
SYNC	Flashes when SMS 40 sends/receives SMS.
VCC	A steady light means that supply voltage is OK.

Accessory card (AA5)

LED	Indication
Power: Green	A steady light means that 12V is OK.
Run: Green	Flashing once/sec. Indicates that the processor is OK.
Com: Green	Flashes irregularly during communication.
PWM1: Orange	Continuous light during active output.
PWM2: Orange	Continuous light during active output.
K1 - K4: Orange	A steady light means that the relevant relay is engaged.

Output	Function
See relevant accessory.	

6 Troubleshooting

Alarm list

A-alarm

A alarm means that:

- the red lamp on the front lights.
- an alarm icon is shown in the display.
- an alarm relay is activated if AUX output is set for this.
- if there are several alarms, these are shown in numerical order (scroll with the OK button).
- there is a comfort reduction according to selection in menu 5.1.4.

Resetting alarms:

- alarm numbers 1 - 39 are reset automatically when a sensor has functioned for 60 seconds or via manual resetting in the menu.
- alarms 40 – 53 manual resetting in menu.
- alarm 54 manual resetting of the motor protection breaker and manual resetting in the menu.
- alarms 55 – 57 manual resetting in menu.
- alarms 70-99 reset automatically when communication is established.
- alarms 100 – 481 manual resetting in menu.

Alm no.	Alarm text on the display	Cause	Heat pump action.	May be due to
2	Sensor fault: BT2 supply temperature sensor 1	The input for the sensor receives unreasonably high or low value for longer than 2 seconds.	* BT12 is used to calculate degree minutes. *Additional heat is blocked. *If BT2 about internally controlled addition is active and GP1 is regulated go to manual operation	See fault-tracing schedule page 39.
3	Sensor fault: BT3 return line sensor 1	The input for the sensor receives unreasonably high or low value for longer than 2 seconds.	GP1 switches to manual speed if auto controlled is selected.	See fault-tracing schedule page 40.
6	Sensor fault BT6 hot water charging	The input for the sensor receives unreasonably high or low value for longer than 2 seconds.	Blocks hot water	See fault-tracing schedule page 38.
10	Sensor fault BT10 brine in	Sensor not connected/defective (brine in).	GP2 switches to manual speed if auto controlled is selected.	▪ Defective sensor and its connections.
11	Sensor fault BT11 brine out	The input for the sensor receives unreasonably high or low value for longer than 2 seconds.	Compressor blocked. GP2 switches to manual speed if auto controlled is selected.	▪ Defective sensor and its connections.
12	Sensor fault BT12 condenser out	The input for the sensor receives unreasonably high or low value for longer than 2 seconds.	Compressor blocked. GP2 switches to manual speed if auto controlled is selected.	▪ Defective sensor and its connections.
25	Sensor fault BT25 external supply	The input for the sensor receives unreasonably high or low value for longer than 2 seconds.	All additions are blocked. New actual value = BT71 + 10K	▪ Defective sensor and its connections.

Alarm no.	Alarm text on the display	Cause	Heat pump action.	May be due to
26	Sensor fault AZ1-BT26 collector in	The input for the sensor receives unreasonably high or low value for longer than 2 seconds.	Circulation pump (AZ1-GP2) in FLM is blocked.	<ul style="list-style-type: none"> Defective sensor and its connections.
28	Sensor fault BT71 ext return line sensor	The input for the sensor receives unreasonably high or low value for longer than 2 seconds.	No action, but if at the same time as Alarm 25, heating is blocked.	<ul style="list-style-type: none"> Defective sensor and its connections.
29	Sensor fault BT29 oil temp.sensor	The input for the sensor receives unreasonably high or low value for longer than 2 seconds.	Compressor heater is active if compressor is not in operation.	<ul style="list-style-type: none"> Defective sensor and its connections.
33	Sensor fault EP30-BT53 solar panel temperature	The input for the sensor receives unreasonably high or low value for longer than 2 seconds.	Solar accessory is blocked	<ul style="list-style-type: none"> Defective sensor and its connections.
34	Sensor fault EP30-BT54 solar tank	The input for the sensor receives unreasonably high or low value for longer than 2 seconds.	Solar accessory is blocked	<ul style="list-style-type: none"> Defective sensor and its connections.
35	Sensor fault EM1-BT52 boiler sensor	The input for the sensor receives unreasonably high or low value for longer than 2 seconds.	Shunt closes. Burner stops. Circ.pump (GP15) stops. Immersion heater blocking stops.	<ul style="list-style-type: none"> Defective sensor and its connections.
36	Sensor fault EP21_BT2 supply sensor	The input for the sensor receives unreasonably high or low value for longer than 2 seconds.	Shunt waiting time for EP21 – QN25 is shunt waiting time2*10 and Sensor signal is replaced by "EP21-BT3"-10K during shunt control.	<ul style="list-style-type: none"> Defective sensor and its connections.
37	Sensor fault EP22_BT2 supply sensor	The input for the sensor receives unreasonably high or low value for longer than 2 seconds.	Shunt waiting time for EP22 – QN25 is shunt waiting time3*10 and Sensor signal replaced by "EP22-BT3"-10K during shunt control.	<ul style="list-style-type: none"> Defective sensor and its connections.
38	Sensor fault EP23_BT2 supply sensor	The input for the sensor receives unreasonably high or low value for longer than 2 seconds.	Shunt waiting time for EP23 – QN25 is shunt waiting time4*10 and Sensor signal replaced by "EP23-BT3"-10K during shunt control.	<ul style="list-style-type: none"> Defective sensor and its connections.
39	Sensor fault EQ1-BT64 cooling supply	The input for the sensor receives unreasonably high or low value for longer than 2 seconds.	Shuts off cooling, Closes shunt (QN18) for cooling.	<ul style="list-style-type: none"> Defective sensor and its connections.
50	High pressure alarm	The high pressure switch has deployed 2 times within 150 minutes or has been deployed for 300 minutes continuously.	Compressor blocked.	See fault-tracing schedule page 43.

Alm no.	Alarm text on the display	Cause	Heat pump action.	May be due to
51	Low pressure alarm	Low pressure switch has tripped. The alarm is blocked for 1 minute at each switch between operating modes.	Compressor blocked.	See fault-tracing schedule page 44.
52	Temperature limiter alarm	Temperature limiter has deployed and been "open" for longer than 30s	None (Handled by hardware)	See fault-tracing schedule page 46.
53	Level monitor Brine	Brine level monitor / pressure switch has tripped (accessory).	Brine pump should stop, also the compressor.	<ul style="list-style-type: none"> ■ Any leakage on the brine circuit.
55	Hot gas alarm	3 hot gas stops during 240 minutes.	Compressor –Epxx is blocked	Call a qualified refrigeration technician.
56	Incorrect serial number	The heat pump has a serial number that does not exist.	The compressor stops, all relay outputs are set to 0 V	
57	Incorrect software	Serial number and program do not match	The compressor stops, all relay outputs are set to 0 V	
58	Pressure switch alarm	High pressure switch BP1 is above its limit value (electromechanical) or Low pressure switch BP2 is below its limit value. For safety reasons, this generates a hardware stoppage. For NIBE inverter this alarm occurs at Address 0x1500, BIT 3	<ul style="list-style-type: none"> ■ Compressor is blocked ■ Brine pump starts at 100 % at next start if its operating mode is selected to auto. 	See fault-tracing schedule page 46.
60	Low temp brine out	The temperature of the outgoing brine goes below the set min-temperature and the alarm is selected to be permanent.	Compressor blocked.	<ul style="list-style-type: none"> ■ Poor circulation in the brine circuit. - Check the brine pump. - Check that the brine is bled. - Check the brine's freezing point.
70	Communication fault with PCA Input.	Communication with the input board missing for 60 secs.	None. For sensors that are no longer available, see each sensor's alarm action	See fault-tracing schedule page 47.
71	Communication fault with PCA base	Communication with the base card missing for 15 secs.	Compressor –EPxx is blocked	See fault-tracing schedule page 48.
100	Communication fault with inverter	Communication with the inverter missing for 15 secs.	Compressor blocked.	<ul style="list-style-type: none"> ■ Communication cables.
299	Incorrect version, PCA Base	The software version of the base board (AA2) is too low for inverter communication.	Compressor is blocked	<ul style="list-style-type: none"> ■ Base board needs replacing (AA2)

Alarm no.	Alarm text on the display	Cause	Heat pump action.	May be due to
421	Inverter alarm type II	A temporary communication alarm has occurred 3 times within 2 hours or has been persistent for 1 hour.	Compressor blocked. Manual reset in menu.	<ul style="list-style-type: none"> ■ Main and group fuses, as well as their cable connections.
423	Inverter alarm type II	A temporary alarm on the inverter's external input has occurred 3 times within 2 hours or the input has been broken continuously for 1 hour.	Compressor blocked. Manual reset in menu.	<ul style="list-style-type: none"> ■ Communication cable to the inverter and its connections.
427	Inverter alarm type III	A temporary internal fault in the inverter has occurred 3 times within 2 hours or has been persistent for 1 hour.	Compressor blocked.	<ul style="list-style-type: none"> ■ Main and group fuses and their cable connections. - Restart the heat pump by switching it off via its switch and cut the current via the circuit breaker for example.
429	Inverter alarm type II	A temporary internal fault in the inverter has occurred 3 times within 2 hours or has been persistent for 1 hour.	Compressor blocked.	<ul style="list-style-type: none"> ■ Main and group fuses, as well as their cable connections.
431	Inverter alarm type I	Continuous over voltage has been registered by the inverter for 1 hour.	Compressor blocked.	<ul style="list-style-type: none"> ■ Main and group fuses, as well as their cable connections.
433	Inverter alarm type I	Continuous under voltage has been registered by the inverter for 1 hour.	Compressor blocked.	<ul style="list-style-type: none"> ■ Main and group fuses, as well as their cable connections.
435	Inverter alarm type I	One compressor phase to the inverter has been missing continuously for 1 hour.	Compressor blocked.	<ul style="list-style-type: none"> ■ Main and group fuses, as well as their cable connections.
437	Inverter alarm type II	A temporary internal fault in the inverter has occurred 3 times within 2 hours or has been persistent for 1 hour.	Compressor blocked.	<ul style="list-style-type: none"> ■ Main and group fuses and their cable connections. - Restart the heat pump by switching it off via its switch and cut the current via the circuit breaker for example.
439	Inverter alarm type II	The inverter has reached max working temperature temporarily, due to poor cooling 3 times within 2 hours or has been missing continually for 1 hour.	Compressor blocked.	<ul style="list-style-type: none"> ■ Bad circulation in the heating medium circuit. - Bleed heat pump and climate system. - Check that the particle filter is not blocked. - Open any radiator / under-floor heating thermostats. <ul style="list-style-type: none"> ■ Poor position of inverter. - Check screws and paste.

Alarm no.	Alarm text on the display	Cause	Heat pump action.	May be due to
441	Inverter alarm type II	Max current in has been temporarily too high 3 times within 2 hours or missing continually for 1 hour.	Compressor blocked.	<ul style="list-style-type: none"> ■ Main and group fuses, as well as their cable connections.
443	Inverter alarm type II	The inverter has reached max working temperature temporarily, due to poor cooling 3 times within 2 hours or has been missing continually for 1 hour.	Compressor blocked.	<ul style="list-style-type: none"> ■ Bad circulation in the heating medium circuit. - Bleed heat pump and climate system. - Check that the particle filter is not blocked. - Open any radiator / under-floor heating thermostats. ■ Poor position of inverter - Check screws and paste.
445	Inverter alarm type II	A temporary internal fault in the inverter has occurred 3 times within 2 hours or has been persistent for 1 hour.	Compressor blocked.	<ul style="list-style-type: none"> ■ Main and group fuses and their cable connections. - Restart the heat pump by switching it off via its switch and cut the current via the circuit breaker for example.
447	Inverter alarm type II	One phase has been missing 3 times within 2 hours or missing continually for 1 hour.	Compressor blocked.	<ul style="list-style-type: none"> ■ Main and group fuses and their cable connections. ■ Compressor wiring to the inverter.
449	Inverter alarm type II	The compressor has run temporarily at lower speed than minimum permitted 3 times within 2 hours or has been missing continually for 1 hour.	Compressor blocked.	<ul style="list-style-type: none"> ■ Main and group fuses and their cable connections. ■ The compressor and its wiring.
451	Inverter alarm type III	A temporary inverter alarm has occurred 3 times within 2 hours or missing continually for 1 hour. Unused function (false alarm).	Compressor blocked.	<ul style="list-style-type: none"> ■ Main and group fuses and their cable connections. <p>Restart the heat pump by switching it off via its switch and cut the current via the circuit breaker for example.</p>
453	Inverter alarm type II	The current out from the inverter to the compressor has been temporarily too high 3 times within 2 hours or missing continually for 1 hour.	Compressor blocked.	<ul style="list-style-type: none"> ■ Main and group fuses and their cable connections. ■ Internal compressor wiring. -if compressor runs slowly, if no, replace inverter.
455	Inverter alarm type II	The power output from the inverter has been too high temporarily 3 times within 2 hours or missing continually for 1 hour.	Compressor blocked.	<ul style="list-style-type: none"> ■ Main and group fuses and their cable connections. ■ Internal compressor wiring, Inverter. If OK, may be due to compressor.

Am no.	Alarm text on the display	Cause	Heat pump action.	May be due to
461	Inverter alarm type II	(Only 1-phase) The current in to the inverter has been too high temporarily 3 times within 2 hours or missing continually for 1 hour. May be due to low incoming voltage (> 198 VAC)	Compressor blocked.	<ul style="list-style-type: none"> ■ Main and group fuses, as well as their cable connections.
469	Inverter alarm type III	A temporary inverter alarm has occurred 3 times within 2 hours or missing continually for 1 hour. Unused function (false alarm)	Compressor blocked.	<ul style="list-style-type: none"> ■ Main and group fuses and their cable connections. <p>Restart the heat pump by switching it off via its switch and cut the current via the circuit breaker for example.</p>
471	Inverter alarm type III	A temporary inverter alarm has occurred 3 times within 2 hours or missing continually for 1 hour. Unused function (false alarm).	Compressor blocked.	<ul style="list-style-type: none"> ■ Main and group fuses and their cable connections. <p>Restart the heat pump by switching it off via its switch and cut the current via the circuit breaker for example.</p>
473	Inverter alarm type III	A temporary inverter alarm has occurred 3 times within 2 hours or missing continually for 1 hour. Unused function (false alarm).	Compressor blocked.	<ul style="list-style-type: none"> ■ Main and group fuses and their cable connections. <p>Restart the heat pump by switching it off via its switch and cut the current via the circuit breaker for example.</p>
475	Inverter alarm type III	A temporary inverter alarm has occurred 3 times within 2 hours or missing continually for 1 hour. Unused function (false alarm).	Compressor blocked.	<ul style="list-style-type: none"> ■ Main and group fuses and their cable connections. <p>Restart the heat pump by switching it off via its switch and cut the current via the circuit breaker for example.</p>
477	Inverter alarm type III	A temporary inverter alarm has occurred 3 times within 2 hours or missing continually for 1 hour. Unused function (false alarm).	Compressor blocked.	<ul style="list-style-type: none"> ■ Main and group fuses and their cable connections. <p>- Restart the heat pump by switching it off via its switch and cut the current via the circuit breaker for example.</p> <p>- Inverter replacement</p>
479	Inverter alarm type III	A temporary inverter alarm has occurred 3 times within 2 hours or missing continually for 1 hour. Unused function (false alarm).	Compressor blocked.	<ul style="list-style-type: none"> ■ Main and group fuses and their cable connections. <p>- Restart the heat pump by switching it off via its switch and cut the current via the circuit breaker for example.</p> <p>- Inverter replacement</p>

Alarm no.	Alarm text on the display	Cause	Heat pump action.	May be due to
481	Inverter alarm type III	A temporary inverter alarm has occurred 3 times within 2 hours or missing continually for 1 hour. Unused function (false alarm).	Compressor blocked.	<ul style="list-style-type: none"> ■ Main and group fuses and their cable connections. - Restart the heat pump by switching it off via its switch and cut the current via the circuit breaker for example. - Inverter replacement

Information messages

In the event of a B alarm the green light shows on the front and a symbol with a service technician is displayed

in the information window until the alarm is reset. All alarms are automatically reset if the cause is rectified. These alarms are so called information alarms and are not registered in the alarm log.

Alarm no.	Alarm text on the display	Cause	Heat pump action.	May be due to
107	Sensor fault: BT7 HW sensor top	Sensor temporarily missing	Only information	<ul style="list-style-type: none"> ■ The sensor and its connections
110	Sensor fault: BT10 brine in	Sensor temporarily missing	Only information	<ul style="list-style-type: none"> ■ The sensor and its connections
155	Hot gas alarm	Hot gas (BT14) has been temporarily above 135C	The compressor is stopped	- Contact an authorised refrigeration technician
160	Low temp brine out	BT11 < Minimum value of brine out	Resets automatically when the temp has the power step 1	<ul style="list-style-type: none"> ■ Settings
161	High HTFin	Brine in has reached set max temperature.	Resets automatically when the temp has fallen xC	<ul style="list-style-type: none"> ■ Settings
162	High condenser out temperature	Condenser out has reached max permitted temperature	Resets automatically when condenser in has fallen 2 degrees	<ul style="list-style-type: none"> ■ Settings
163	High condenser in temperature	Condenser in has reached max permitted temperature	Resets automatically when condenser in has fallen 2 degrees	<ul style="list-style-type: none"> ■ Settings
166	Electrical anode incorrect	Fault in the electrical anode		
170	Com. error input card	Communication with the input card is temporarily missing.	Only information	<ul style="list-style-type: none"> ■ Communication cables and connections
171	Com. error base card	Communication with the base card is temporarily missing.	Only information	<ul style="list-style-type: none"> ■ Communication cables and connections
180	Freeze prot	Freeze protection active. Occurs if the outdoor temperature is below 3 degrees and no heating is permitted	Permits room heating	<ul style="list-style-type: none"> ■ Operating settings
181	Unsuccessful periodic increase	Periodic increase did not reach the stop temperature in 5 hours.	Only information	<ul style="list-style-type: none"> ■ Operating settings
182	Load monitor activated	One or more power steps cannot be activated because the current in at least one phase is too high	Only information	<ul style="list-style-type: none"> ■ Phase load. ■ It may require a larger main fuse
200	Com. fault inverter	Communication fault with inverter	Only information	<ul style="list-style-type: none"> ■ Not documented (see F750)
274	The compressor's phase has been overloaded.		Only information	<ul style="list-style-type: none"> ■ No action

Alarm no.	Alarm text on the display	Cause	Heat pump action.	May be due to
275	The compressor's phase has been persistently overloaded.		Only information	<ul style="list-style-type: none"> No action
299	Incorrect version, PCA Base	The software version of the base board is too low for inverter communication.	Compressor blocked.	
351	Uncertain sensor accuracy	Uncertain sensor accuracy on brine sensors BT10, BT11. Differs more than 2K between them at calibration.	GP2 switches to manual speed if auto controlled is selected.	<ul style="list-style-type: none"> Connections to sensors BT10, BT11
352	Uncertain sensor accuracy	Uncertain sensor accuracy on HM sensors BT3, BT2. Differs more than 2K between them at calibration.	GP1 switches to manual speed if auto controlled is selected.	<ul style="list-style-type: none"> Connections to sensors BT2, BT3
353	Uncertain sensor accuracy	Uncertain sensor accuracy on HM sensors BT3, BT12. Differs more than 2K between them at calibration.	GP1 switches to manual speed if auto controlled is selected.	<ul style="list-style-type: none"> Connections to sensors BT3, BT12
420	Inverter alarm type II	A temporary communication alarm has occurred.	The compressor is stopped. The compressor makes a new attempt to start 60 s after inverter error has been reset.	<ul style="list-style-type: none"> Main and group fuses, as well as cables to the inverter and its connections.
422	Inverter alarm type II	A temporary alarm on the inverter's external input has occurred.	The compressor is stopped. The compressor makes a new attempt to start 60 s after inverter error has been reset.	<ul style="list-style-type: none"> Main and group fuses and their cable connections.
426	Inverter alarm type III	A temporary internal fault in the inverter has occurred.	The compressor is stopped.	<ul style="list-style-type: none"> Main and group fuses and their cable connections. - Restart the heat pump by switching it off via its switch and cut the current via the circuit breaker for example.
428	Inverter alarm type II	A temporary internal fault in the inverter has occurred.	The compressor is stopped.	<ul style="list-style-type: none"> Main and group fuses and their cable connections. - Restart the heat pump by switching it off via its switch and cut the current via the circuit breaker for example. If the fault occurs again, contact service.
430	Inverter alarm type I	A temporary over voltage has been registered by the inverter.	The compressor is stopped.	<ul style="list-style-type: none"> Main and group fuses and their cable connections.

Alarm no.	Alarm text on the display	Cause	Heat pump action.	May be due to
432	Inverter alarm type I	A temporary under voltage has been registered by the inverter.	The compressor is stopped.	<ul style="list-style-type: none"> ■ Main and group fuses and their cable connections.
434	Inverter alarm type I	A compressor phase has been missing temporarily.	The compressor is stopped.	<ul style="list-style-type: none"> ■ Main and group fuses and their cable connections.
436	Inverter alarm type II	A temporary internal fault in the inverter has occurred.	The compressor is stopped.	<ul style="list-style-type: none"> ■ Main and group fuses and their cable connections. - Restart the heat pump by switching it off via its switch and cut the current via the circuit breaker for example.
438	Inverter alarm type II	The inverter has reached max working temperature temporarily due to poor cooling.	The compressor is stopped.	<ul style="list-style-type: none"> ■ Bad circulation in the heating medium circuit. - Bleed heat pump and climate system. - Check that the particle filter is not blocked. - Open any radiator / under-floor heating thermostats.
440	Inverter alarm type II	Max current in has been too high temporarily.	The compressor is stopped.	<ul style="list-style-type: none"> ■ Main and group fuses and their cable connections.
442	Inverter alarm type II	The inverter has reached max working temperature temporarily due to poor cooling.	The compressor is stopped.	<ul style="list-style-type: none"> ■ Bad circulation in the heating medium circuit. - Bleed heat pump and climate system. - Check that the particle filter is not blocked. - Open any radiator / under-floor heating thermostats.
444	Inverter alarm type II	A temporary internal fault in the inverter has occurred.	The compressor is stopped.	<ul style="list-style-type: none"> ■ Main and group fuses and their cable connections. - Restart the heat pump by switching it off via its switch and cut the current via the circuit breaker for example.
446	Inverter alarm type II	A compressor phase has been missing temporarily.	The compressor is stopped.	<ul style="list-style-type: none"> ■ Main and group fuses and their cable connections.
448	Inverter alarm type II	compressor has run temporarily at a lower speed than the minimum permitted.	The compressor is stopped.	<ul style="list-style-type: none"> ■ Check main and group fuses and their cable connections.

Alarm no.	Alarm text on the display	Cause	Heat pump action.	May be due to
450	Inverter alarm type III	A temporary inverter alarm has occurred. Unused function (false alarm).	The compressor is stopped.	<ul style="list-style-type: none"> ■ Main and group fuses and their cable connections. - Restart the heat pump by switching it off via its switch and cut the current via the circuit breaker for example.
452	Inverter alarm type II	The current out from the inverter to the compressor has been too high temporarily.	The compressor is stopped.	<ul style="list-style-type: none"> ■ Main and group fuses and their cable connections.
454	Inverter alarm type II	Too high power output from the inverter has occurred temporarily.	The compressor is stopped.	<ul style="list-style-type: none"> ■ Main and group fuses and their cable connections.
460	Inverter alarm type II	(Only 1-phase) Too high current in to the inverter has occurred temporarily. May be due to low incoming voltage (> 198 VAC)	The compressor is stopped.	<ul style="list-style-type: none"> ■ Main and group fuses and their cable connections.
468	Inverter alarm type III	A temporary inverter alarm has occurred. Unused function (false alarm).	The compressor is stopped.	<ul style="list-style-type: none"> ■ Main and group fuses and their cable connections. - Restart the heat pump by switching it off via its switch and cut the current via the circuit breaker for example.
470	Inverter alarm type III	A temporary inverter alarm has occurred. Unused function (false alarm).	The compressor is stopped.	<ul style="list-style-type: none"> ■ Check main and group fuses and their cable connections. - Restart the heat pump by switching it off via its switch and cut the current via the circuit breaker for example.
472	Inverter alarm type III	A temporary inverter alarm has occurred. Unused function (false alarm).	The compressor is stopped.	<ul style="list-style-type: none"> ■ Check main and group fuses and their cable connections. - Restart the heat pump by switching it off via its switch and cut the current via the circuit breaker for example.
474	Inverter alarm type III	A temporary inverter alarm has occurred. Unused function (false alarm).	The compressor is stopped.	<ul style="list-style-type: none"> ■ Check main and group fuses and their cable connections. - Restart the heat pump by switching it off via its switch and cut the current via the circuit breaker for example.

Am no.	Alarm text on the display	Cause	Heat pump action.	May be due to
476	Inverter alarm type III	A temporary inverter alarm has occurred. Unused function (false alarm).	The compressor is stopped.	<ul style="list-style-type: none"> ■ Check main and group fuses and their cable connections. - Restart the heat pump by switching it off via its switch and cut the current via the circuit breaker for example.
478	Inverter alarm type III	A temporary inverter alarm has occurred. Unused function (false alarm).	The compressor is stopped.	<ul style="list-style-type: none"> ■ Check main and group fuses and their cable connections. - Restart the heat pump by switching it off via its switch and cut the current via the circuit breaker for example.
480	Inverter alarm type III	A temporary inverter alarm has occurred. Unused function (false alarm).	The compressor is stopped.	<ul style="list-style-type: none"> ■ Check main and group fuses and their cable connections. - Restart the heat pump by switching it off via its switch and cut the current via the circuit breaker for example.
990	Country not defined	Country not selected	Only info. Resets when country is selected in menu 5.12	
995	External alarm	An alarm according to selected function on AUX input.	Only info.	<ul style="list-style-type: none"> ■ Check any external connection functions.
996	Blocked	Additional heat is externally blocked via AUX input.	Additional heat is blocked	<ul style="list-style-type: none"> ■ Check any external connection functions.
997	Blocked	Additional heat is externally blocked via AUX input.	Compressor is blocked	<ul style="list-style-type: none"> ■ Check any external connection functions.

Troubleshooting guide

Alarm 1, 25 – sensor fault

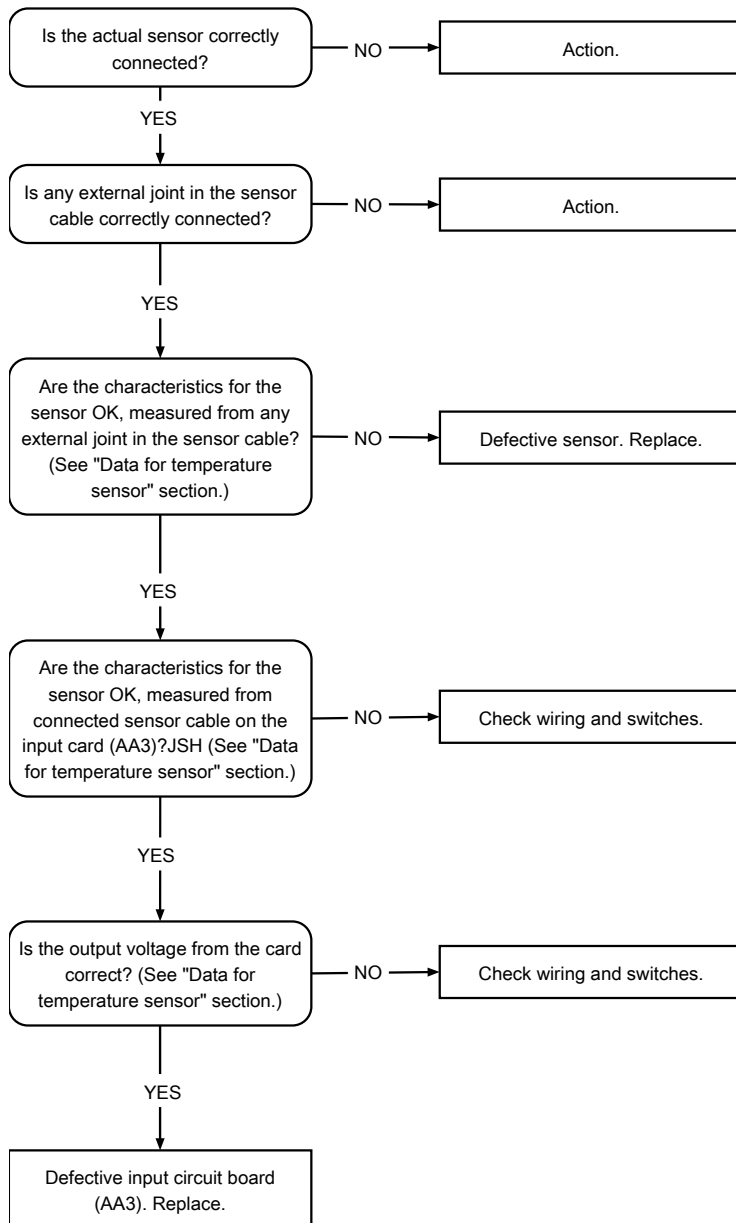

Alarm 2 – sensor fault

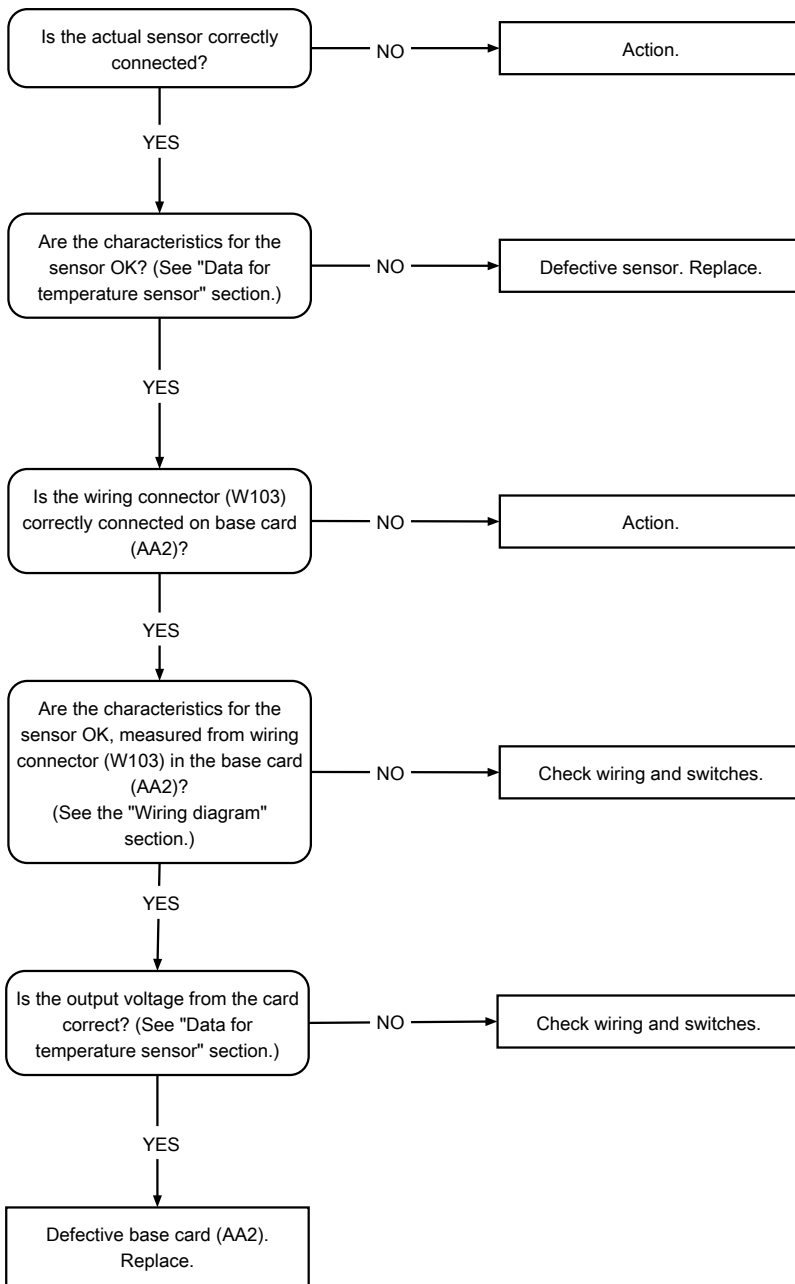

Alarm 3, 11, 12 – sensor fault

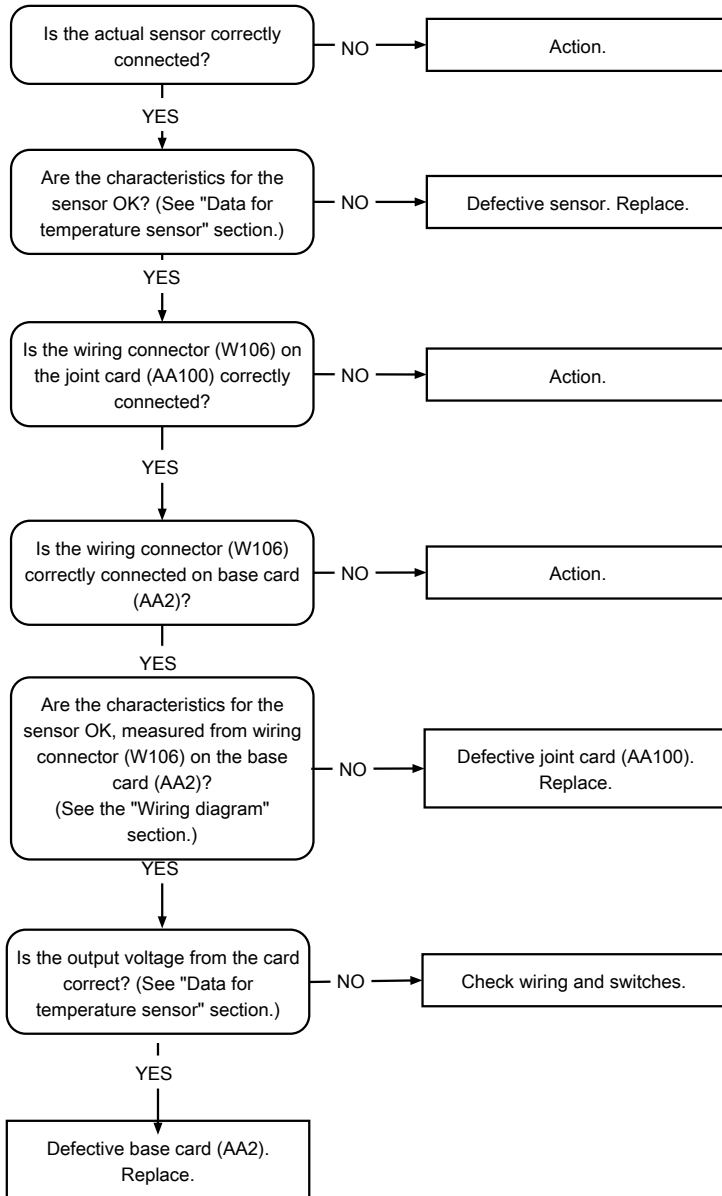

Alarm 20, 21, 26 – sensor fault

Fault-tracing in NIBE FLM

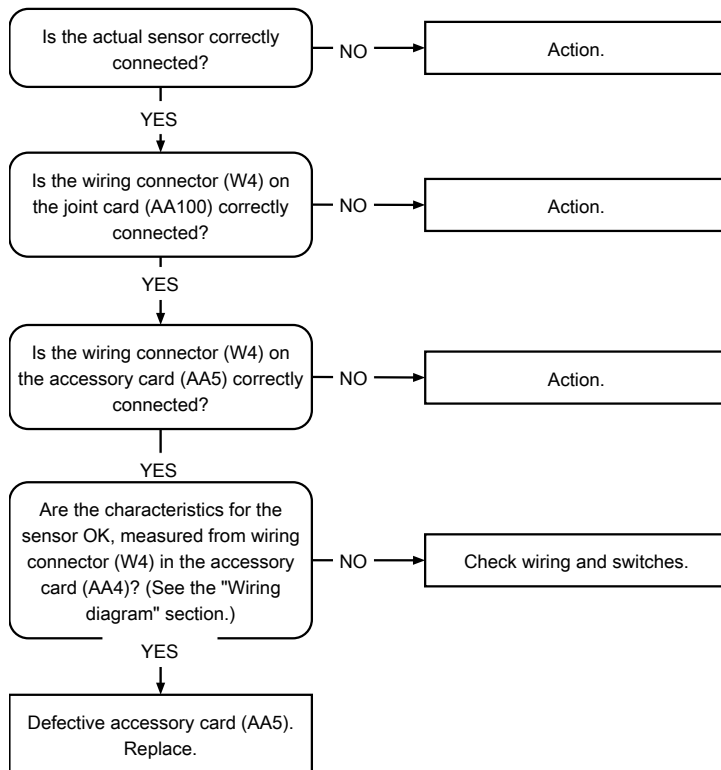

Alarm 33-39 – sensor fault

Fault-tracing in accessory card.

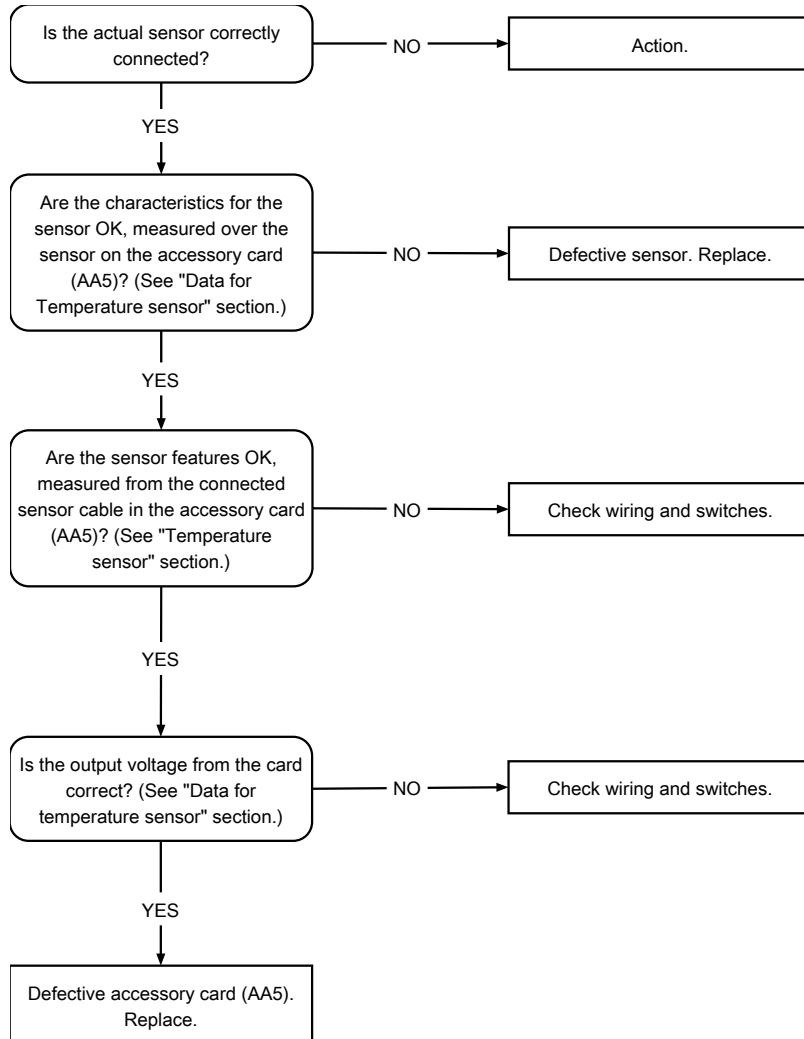

Alarm 50 – high pressure alarm

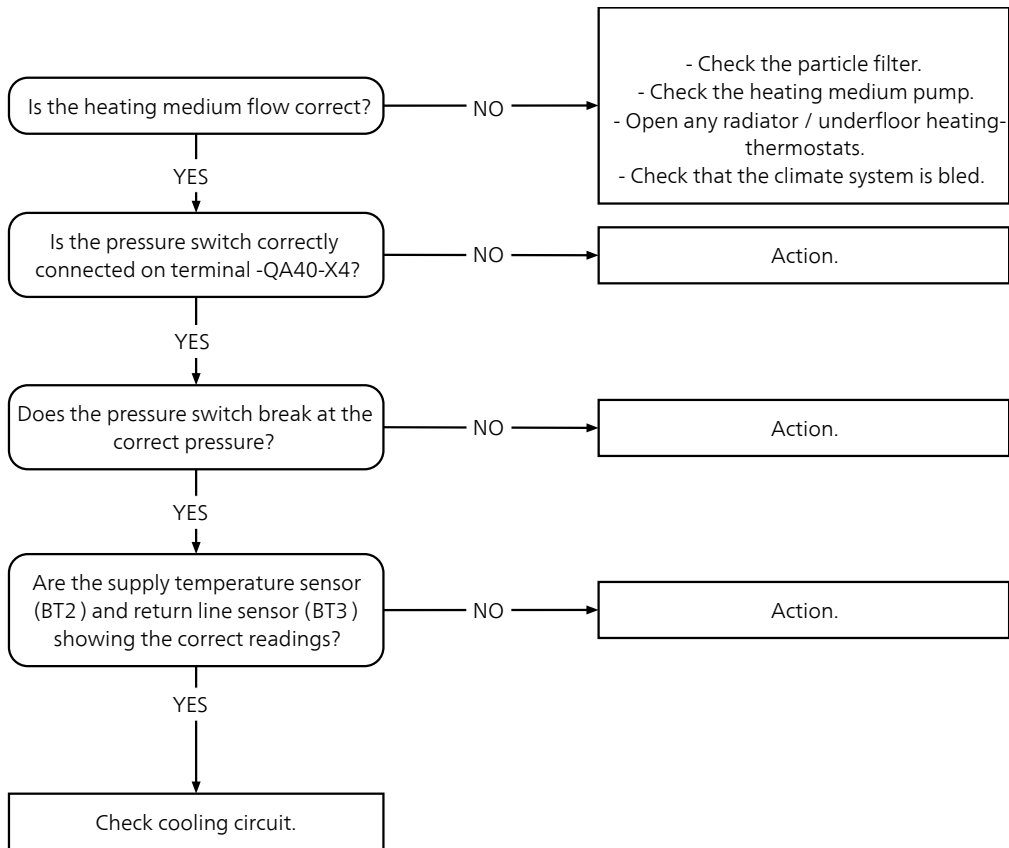

Alarm 51 – low pressure alarm

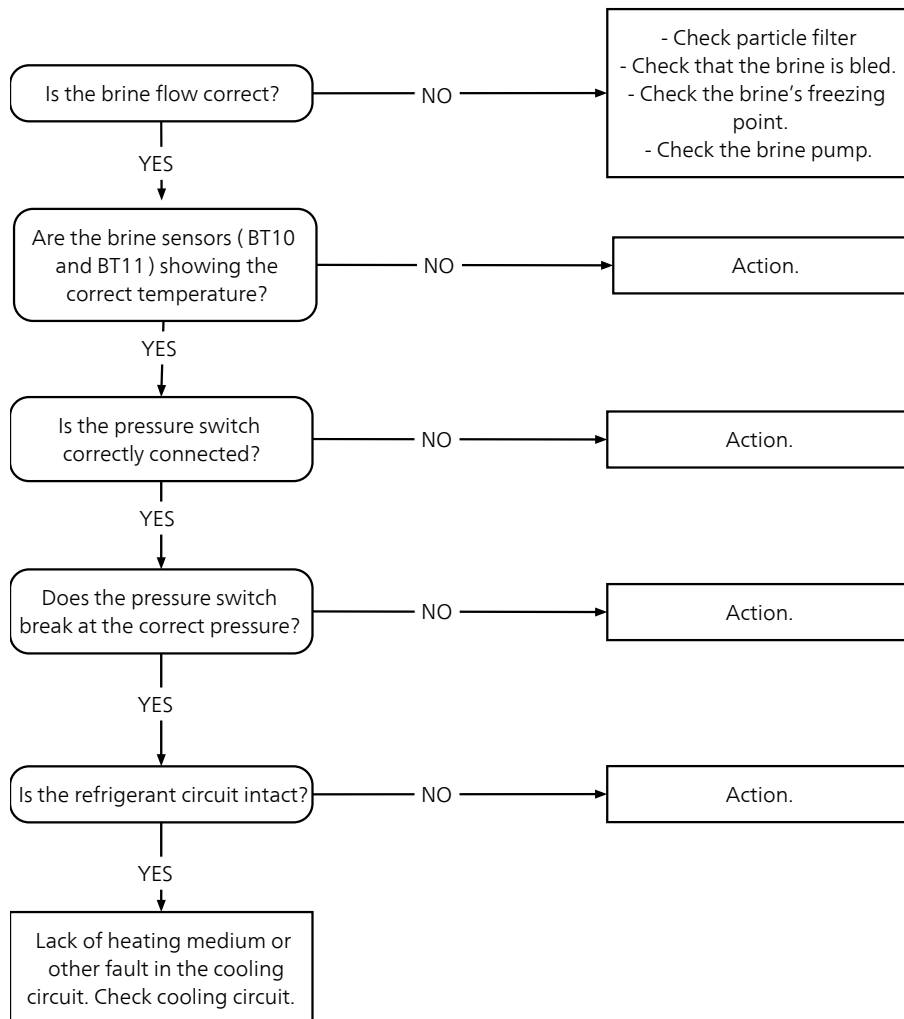

Alarm 52 – temperature limiter

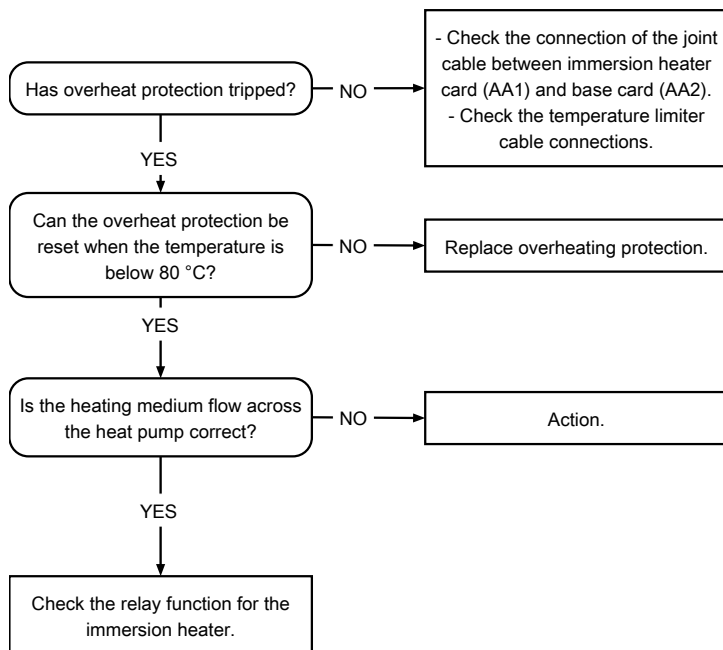

Alarm 58 - pressure switch alarm

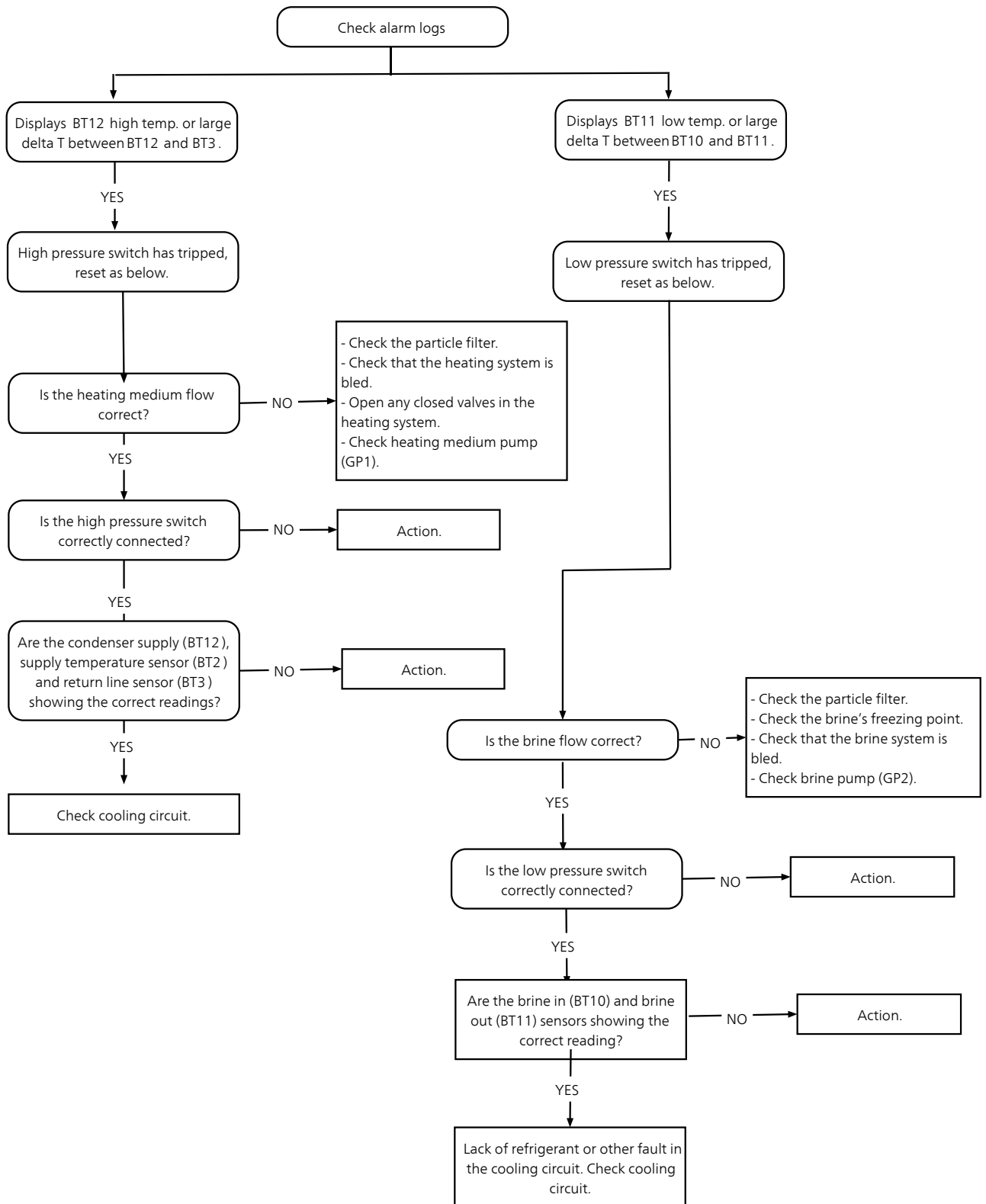

Alarm 70 - perm. com.error input card

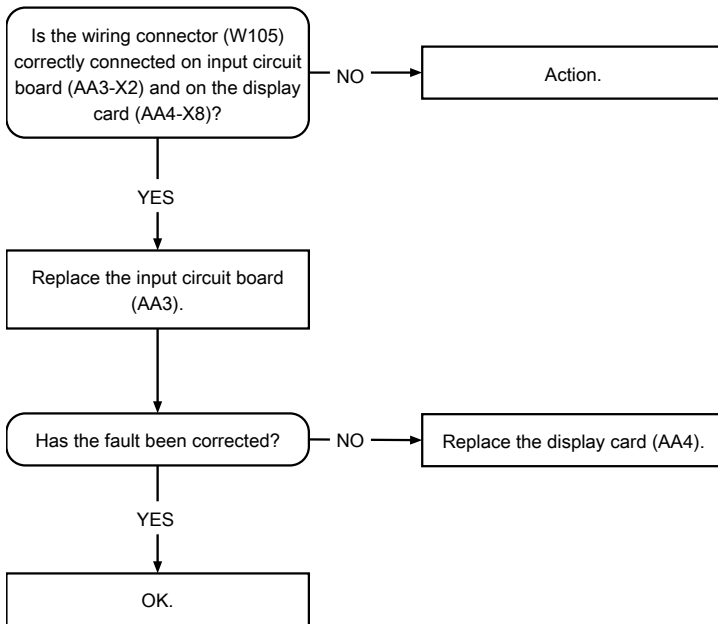

Alarm 71 - perm. com.error input card

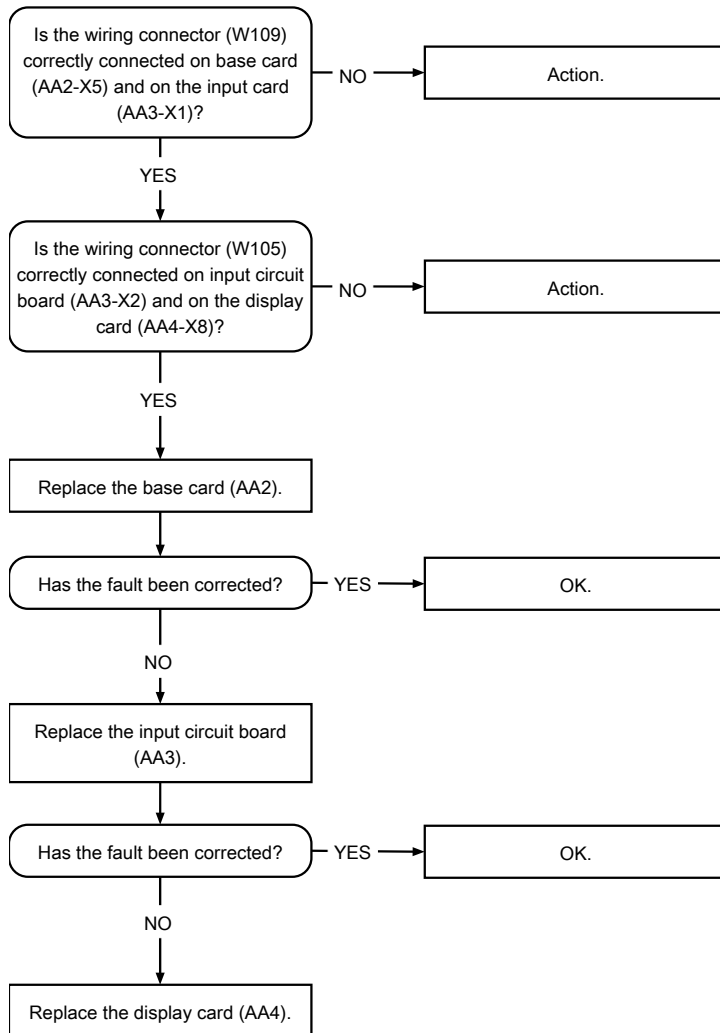

Alarm 73–95 - perm. com.error accessory card

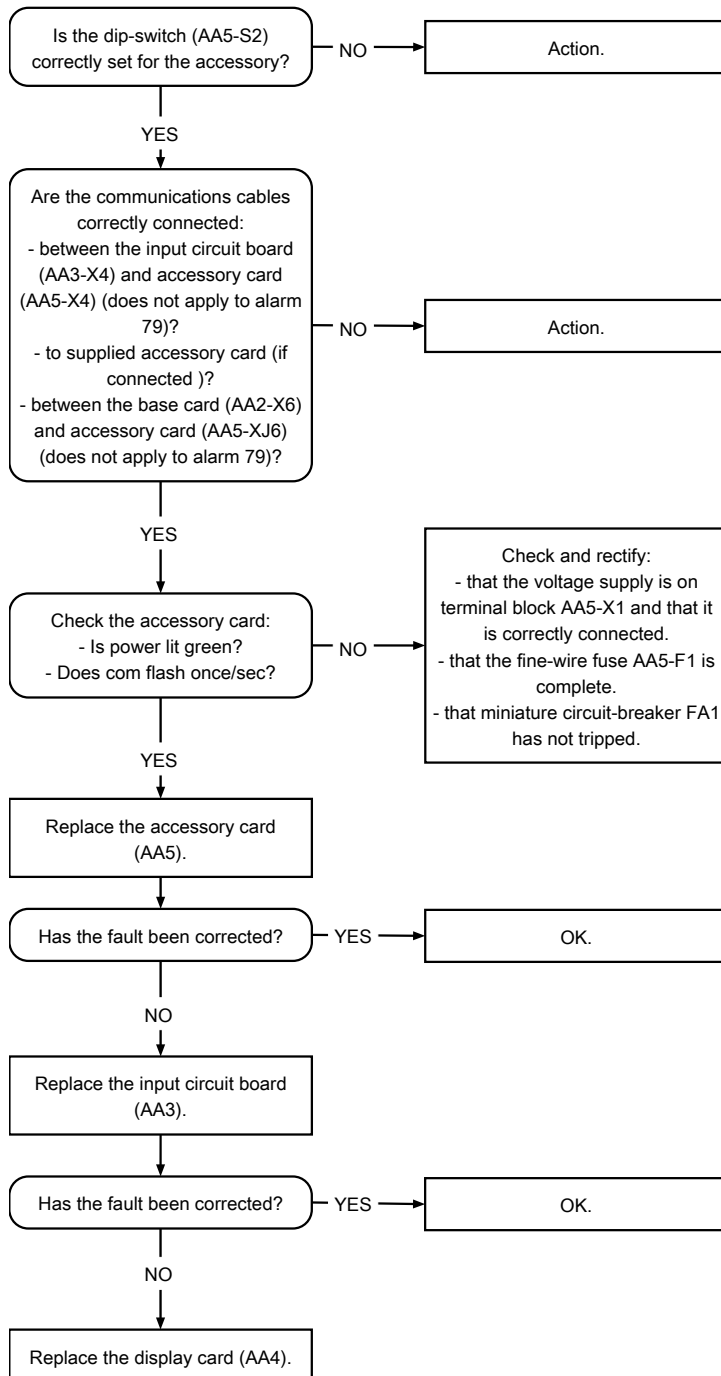

Alarm 100 – Inverter fault

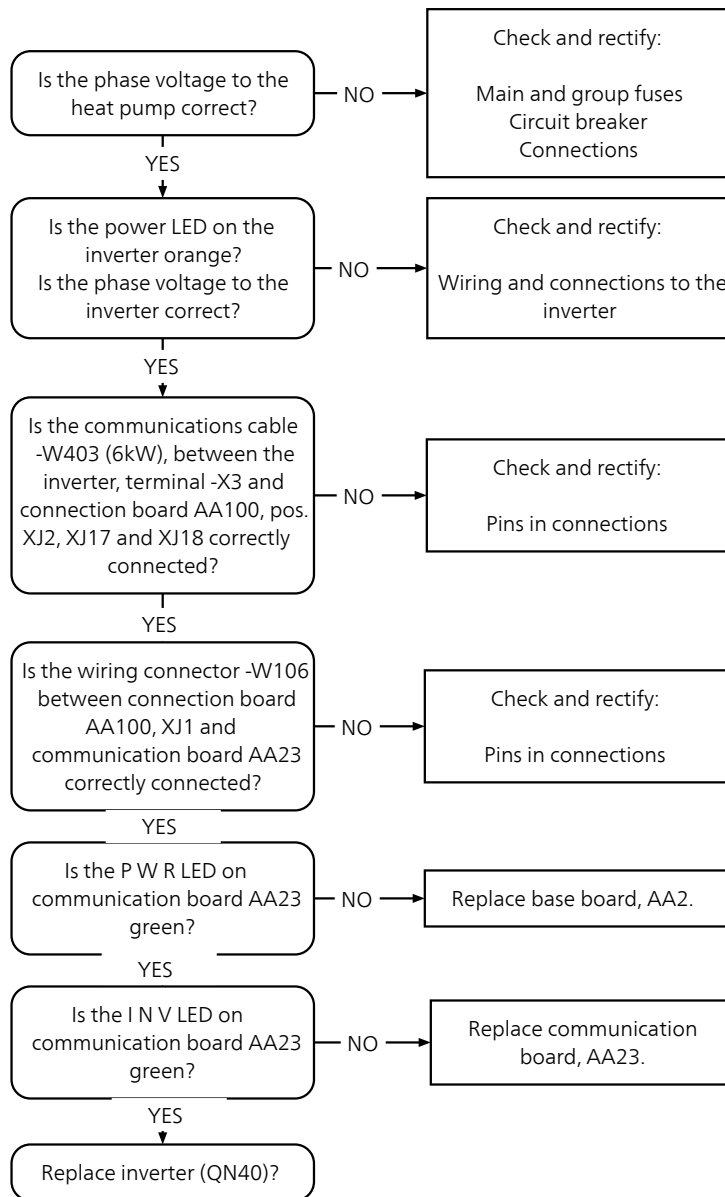

Function check, relays/components

Relay test - forced control

The heat pumps relay outputs can be force controlled from menu 5.6.

1. Tick "activated". Forced control is then activated for 10 minutes.
2. Tick the outputs that you want to activate.
3. Check the relay/component function.



WARNING!

Forced control must only be used by users familiar with the system. When forced control is activated, the alarm functions are disabled.

Internal outputs

LED	Indication
K1 - K10: Orange	A steady light means that the relevant relay is engaged.

Output	Function		
	1x230 V	3x230 V	3x400 V
K1	Supply L1	Supply L1	Supply L1
K2	Supply L1	Supply L2	Supply L2
K3	Supply L1	Supply L2	Supply L3
K4	Immersion heater 0.5 kW	Supply L3	1255-6: Immersion heater 0.5 kW 1255-16: 2 kW
K5	No function	Supply L3	1255-6: Immersion heater 3 kW on K9 1255-16: No function
K6	Immersion heater 1 kW	Immersion heater 2 kW	1255-6: Immersion heater 1 kW 1255-16: Immersion heater 2 kW

Output	Function		
	No function	Immersion heater 0.5 kW	1255-6: No function 1255-16: Immersion heater 3 kW on K9
K7	No function	Immersion heater 0.5 kW	1255-6: No function 1255-16: Immersion heater 3 kW on K9
K8	Immersion heater 2 kW	No function	1255-6: Immersion heater 2 kW 1255-16: Immersion heater 2 kW
K9	Immersion heater 1 kW	Immersion heater 1 kW	1255-6: Immersion heater 3 kW on K5 1255-16: Immersion heater 1/3 kW
K10		Immersion heater 1kW	

Climate system 2 (ECS 40/41)

Output	Function
EP21-AA5-K2	Mixing valve, close
EP21-AA5-K3	Mixing valve, open
EP21-AA5-K4	External circulation pump

Climate system 3 (ECS 40/41)

Output	Function
EP22-AA5-K2	Mixing valve, close
EP22-AA5-K3	Mixing valve, open
EP22-AA5-K4	External circulation pump

Climate system 4 (ECS 40/41)

Output	Function
EP23-AA5-K2	Mixing valve, close
EP23-AA5-K3	Mixing valve, open
EP23-AA5-K4	External circulation pump

Climate system 5 (ECS 40/41)

Output	Function
EP44-AA5-K2	Mixing valve, close
EP44-AA5-K3	Mixing valve, open
EP44-AA5-K4	External circulation pump

Climate system 6 (ECS 40/41)

Output	Function
EP45-AA5-K2	Mixing valve, close
EP45-AA5-K3	Mixing valve, open
EP45-AA5-K4	External circulation pump

Climate system 7 (ECS 40/41)

Output	Function
EP46-AA5-K2	Mixing valve, close
EP46-AA5-K3	Mixing valve, open
EP46-AA5-K4	External circulation pump

Climate system 8 (ECS 40/41)

Output	Function
EP47-AA5-K2	Mixing valve, close
EP47-AA5-K3	Mixing valve, open
EP47-AA5-K4	External circulation pump

Mixing valve controlled additional heat (AXC 40)

Output	Function
EM1-AA5-K1	External addition (burner) permitted
EM1-AA5-K2	Mixing valve, close
EM1-AA5-K3	Mixing valve, open
EM1-AA5-K4	External circulation pump

Pool 1 (POOL 40)

Output	Function
CL11-A5-K1	External circulation pump
CL11-A5-K3	Pool reversing valve
CL11-A5-K4	Pool pump

Pool 2 (POOL 40)

Output	Function
CL12-A5-K1	External circulation pump
CL12-A5-K3	Pool reversing valve
CL12-A5-K4	Pool pump

Exhaust air module 1 (FLM)

Output	Function
AZ1-AA5-K3	Fan (relay)
AZ1-AA5-K4	Brine pump FLM

Exhaust air module 2 (FLM)

Output	Function
AZ2-AA5-K3	Fan (relay)
AZ2-AA5-K4	Brine pump FLM

Exhaust air module 3 (FLM)

Output	Function
AZ3-AA5-K3	Fan (relay)
AZ3-AA5-K4	Brine pump FLM

Exhaust air module 4 (FLM)

Output	Function
AZ4-AA5-K3	Fan (relay)
AZ4-AA5-K4	Brine pump FLM

Ground water pump (AXC 40)

Output	Function
EP12-AA5-K4	Groundwater pump

Passive cooling 2-pipe (PCM40/PCM42)

Output	Function
EQ1-AA5-K1	External circulation pump
EQ1-AA5-K2	Shunt valve, (QN18) close
EQ1-AA5-K3	Shunt valve, (QN18) open
EQ1-AA5-K4	Reversing valve (QN12)

Passive cooling 4-pipe (PCS44)

Output	Function
EQ1-AA5-K1	Circulation pump cooling (GP13)
EQ1-AA5-K2	Mixing valve (QN18), close
EQ1-AA5-K3	Mixing valve (QN18), open

Passive/active cooling (HPAC, ACS45)

Output	Function
EQ1-AA5-K1	AC
EQ1-AA5-K2	PC
EQ1-AA5-K4	External circulation pump

Step controlled additional heat (AXC40)

Output	Function
EB1-AA5-K1	Step 1
EB1-AA5-K2	Step 2
EB1-AA5-K3	Step 3

Function check, circulation pumps

With forced control of the heating medium pump (GP1) or the brine pump (GP2) it can be necessary to check the supply (230 V AC) and the control signal (0-10 V DC) to the circulation pump.

Heating medium pump (GP1) Grundfos

Pump speed GP1	PVM1, X2:1-2	LED PWM1 on Board AA2
100 %	approx 0 V DC	Not lit
50 %	approx 5 V DC	Half lit
0 %	approx 10 V DC	Lit

Brine pump (GP2) Grundfos

Pump speed GP2	PVM2, X2:3-4	LED PWM2 on Board AA2
100 %	approx 0 V DC	Not lit
50 %	approx 5 V DC	Half lit
0 %	approx 10 V DC	Lit

Fan (GQ10) FLM

Fan speed GQ10	PVM2, X2:3-4	LED PWM2 on Board AA2
100 %	approx 0 V DC	Not lit
50 %	approx 5 V DC	Half lit
0 %	approx 10 V DC	Lit

7 Component replacement



NOTE

Servicing should only be carried out by persons with the necessary expertise.

Cut the current with the circuit breaker before carrying out any servicing.

F1255 can contain liquids at high temperature and under high pressure.

When replacing components on F1255 only replacement parts from NIBE may be used.

An ESD bracelet must be worn when replacing the card.

Basic

Removing the covers

Front cover

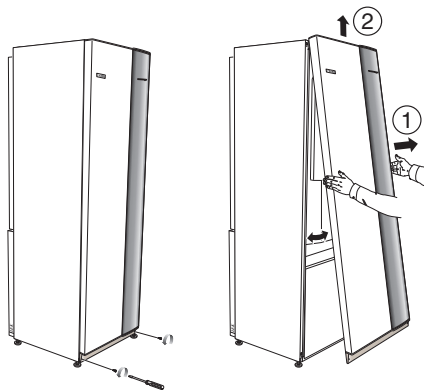

1. Remove the screws from the lower edge of the front cover.
2. Lift the cover out at the bottom edge and up.

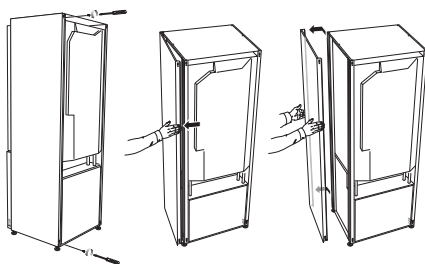

The side covers can be removed to facilitate the installation.

1. Remove the screws from the upper and lower edges.
2. Twist the cover slightly outward.
3. Move the hatch outwards and backwards.
4. Assembly takes place in the reverse order.

Top panel

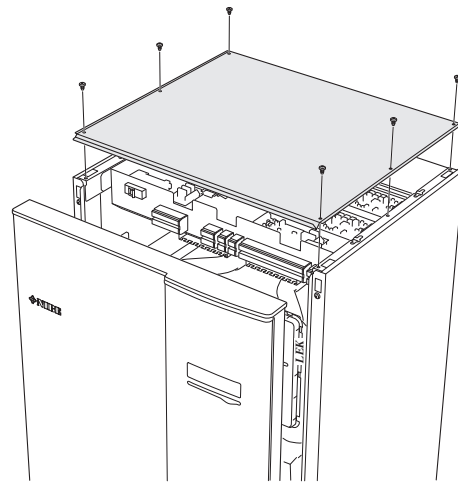

1. Lift off the front cover, according to the previous instructions.
2. Remove the six screws in the top panel.
3. Lift the top panel straight up.

Pulling out the cooling module

The cooling module can be pulled out for service and transport.



NOTE

Shut off the heat pump and turn off the current on the safety breaker.



Caution

Drain the cooling module according to IHB to facilitate lifting.



Caution

Remove the front cover according to the description on page 54.

1. Close the shut-off valves (QM31), (QM32), (QM33) and (QM34).

Drain the cooling module according to IHB.

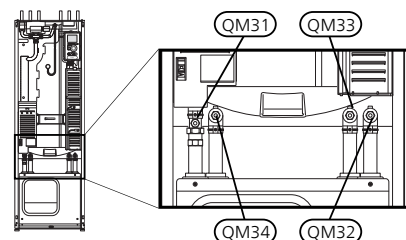

- 2 Pull off the lock catches.

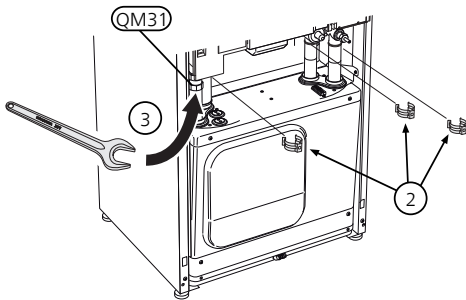

- 3 Disconnect the pipe connection at the shut-off valve (QM31).

- 4 Remove the two screws.

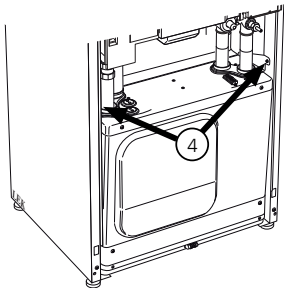

- 5 Remove the connection from the base card (AA2) using a screwdriver.

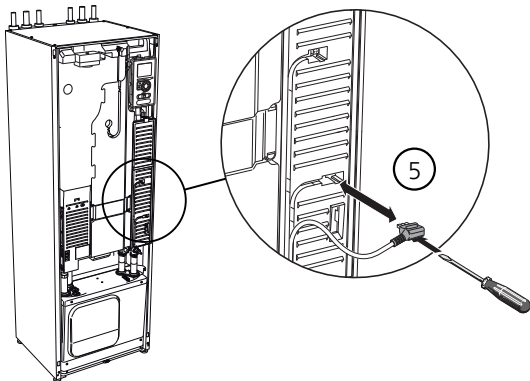

- 6 Disconnect the connectors (A) and (B) from the underside of the base card cabinet.

- 7 Disconnect the connector (C) from the immersion heater circuit board (AA1) using a screwdriver.

- 8 Disconnect the connector (D) from the joint circuit board (AA100).

- 9 Carefully pull out the cooling module.

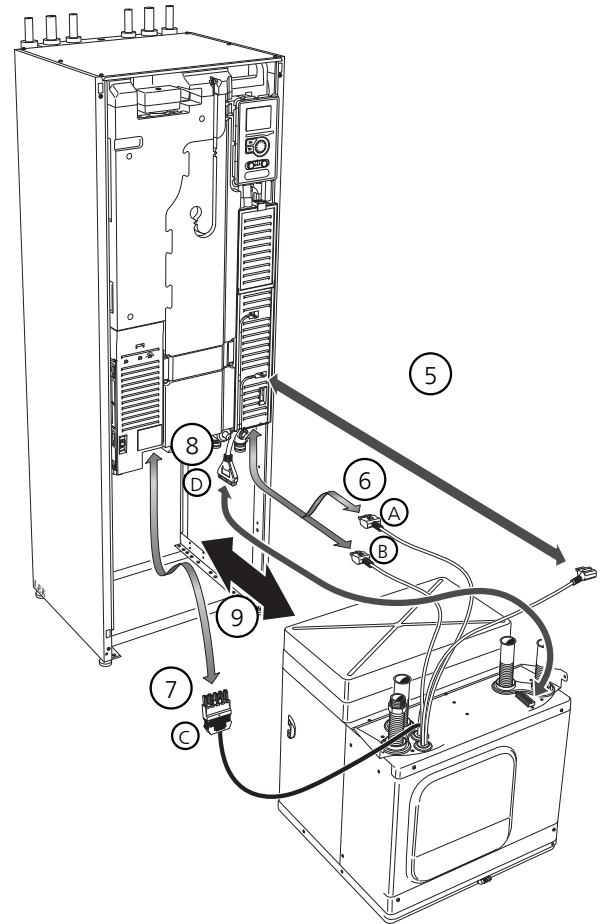

TIP

The cooling module is installed in reverse order.



NOTE

At reinstallation, the supplied O-rings must replace the existing ones at the connections to the heat pump (see image).

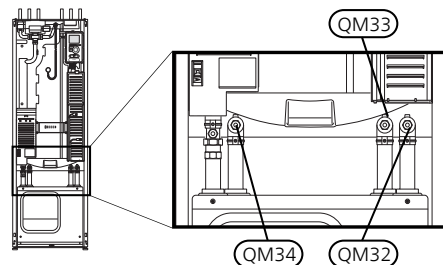

Accessibility, electrical connection

The plastic cap of the electrical boxes is opened using a screwdriver.

- NOTE**
- The cover for the input card is opened without a tool.

Removing the cover, input circuit board

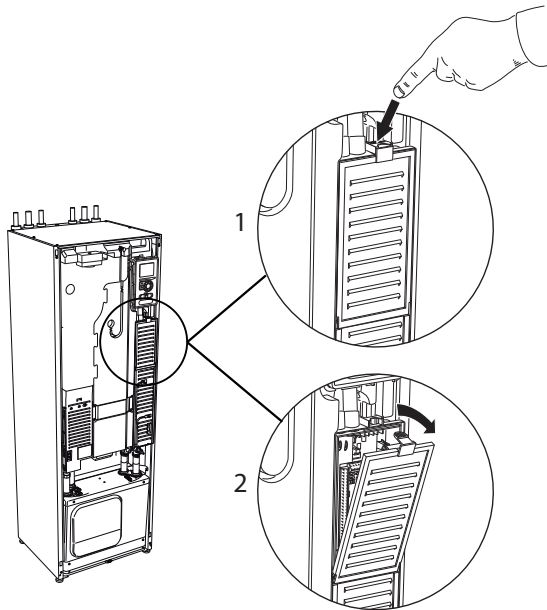

1. Push the catch down.
2. Angle out the cover and remove it.

Removing the cover, immersion heater circuit board

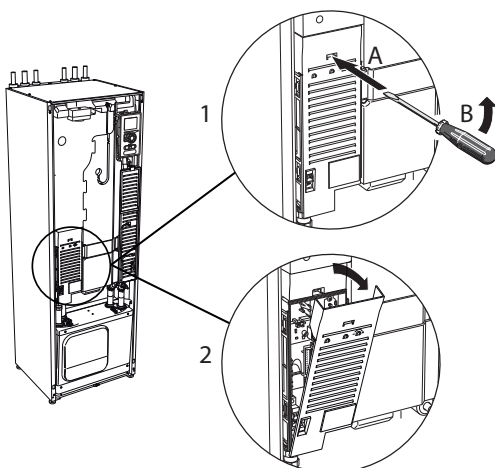

1. Insert the screwdriver (A) and pry the catch carefully downwards (B).
2. Angle out the cover and remove it.

Removing the cover, base board

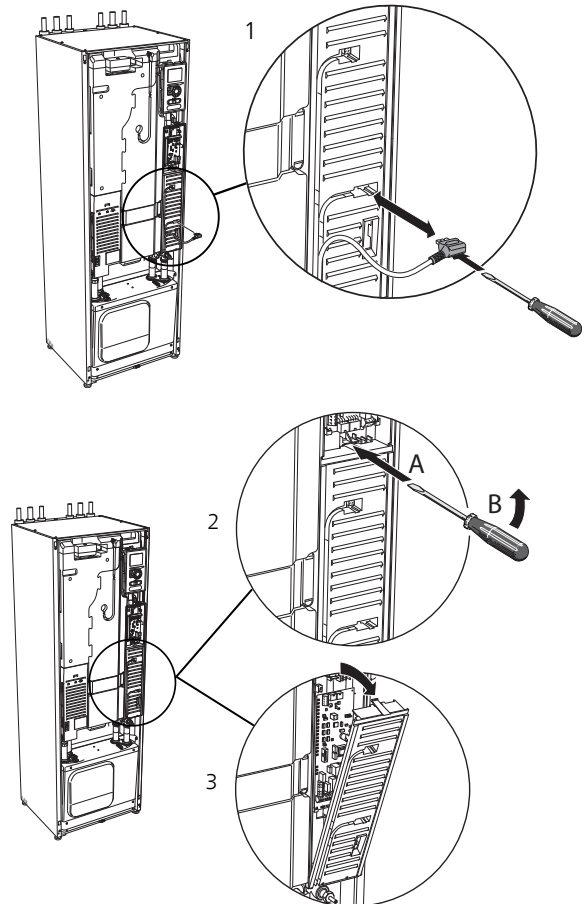

- Caution**
- To remove the cover for the base board, the cover for the input circuit board must first be removed.



1. Disconnect the switches using a screwdriver.
2. Insert the screwdriver (A) and pry the catch carefully downwards (B).
3. Angle out the cover and remove it.

Main components

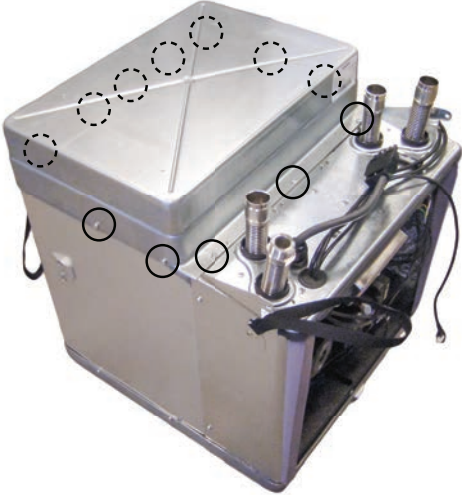
Compressor (GQ10)

<p>1 Remove the cooling module according to the instruction on page 54.</p>	
<p>3 Slacken off 12 screws. 4 Remove the cover on the cooling module.</p>	
<p>5 Slacken off 8 screws. 6 Remove the right/rear side panel on the cooling module.</p>	

7 Slacken off 7 screws.

8 Remove the left/rear side panel on the cooling module.



9 Unscrew the ground cable.

10 Disconnect the compressor supply cables.

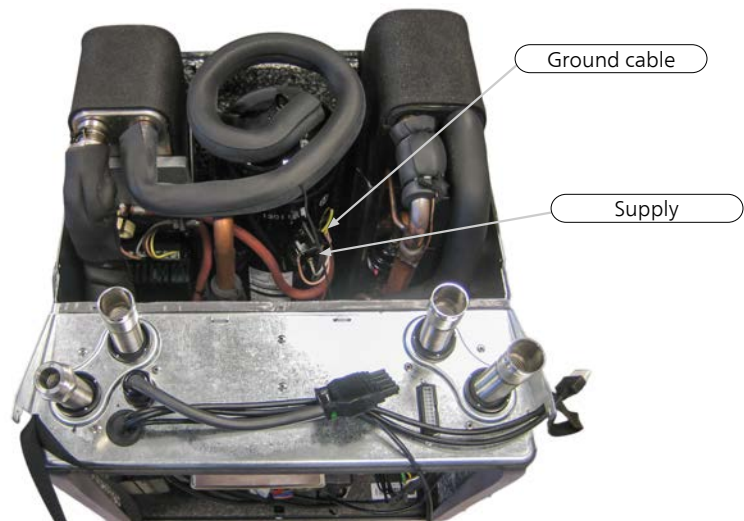

11 Remove the 4 locking plates holding the compressor.

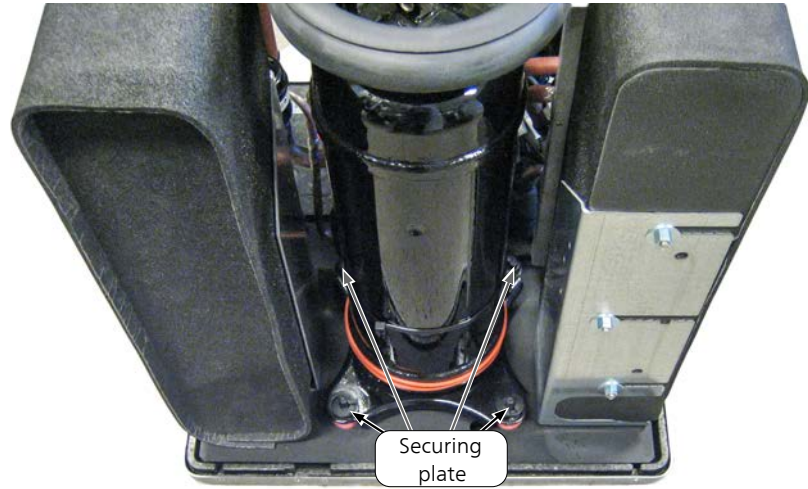

12 Drain the cooling circuit and ensure that no refrigerant remains before you continue.

13 Disconnect the pipes for suction gas and hot gas.

14 Remove the compressor.

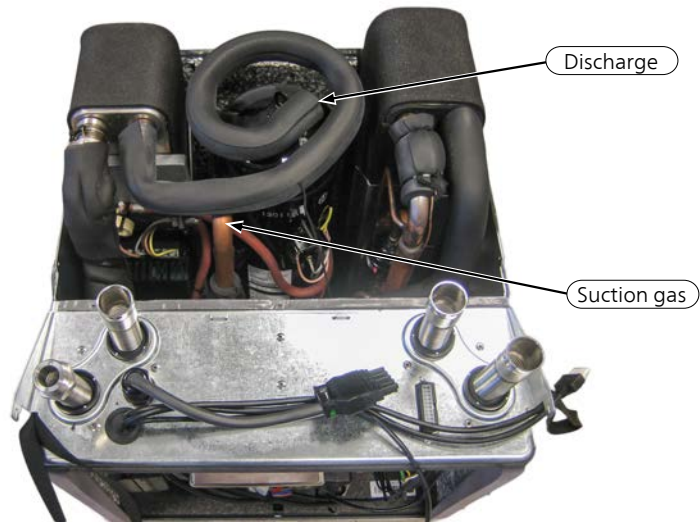

Expansion valve (QN1)

<p>1 Remove the cooling module according to the instruction on page 54.</p>	
<p>3 Slacken off 12 screws. 4 Remove the cover on the cooling module.</p>	
<p>5 Slacken off 8 screws. 6 Remove the right/rear side panel on the cooling module.</p>	

7 Drain the cooling circuit and ensure that no refrigerant remains before you continue.

8 Slacken off the bulb for the expansion valve.

9 Disconnect the pipes and remove the valve.

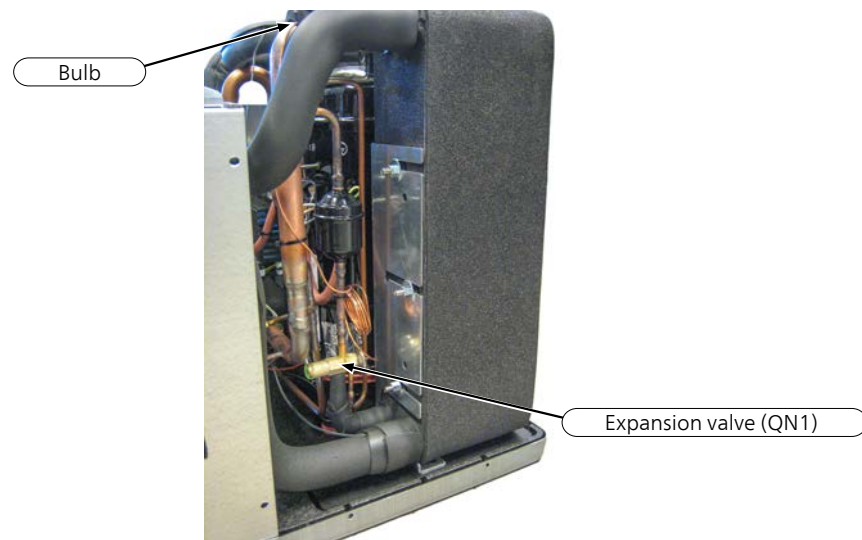

Immersion heater (EB1)

1 Drain the heating medium system.

2 Remove the plastic cap over (AA1) using a screwdriver.



3 Remove the insulation in front of the immersion heater and remove supply sensor (BT2) from the submerged tube.

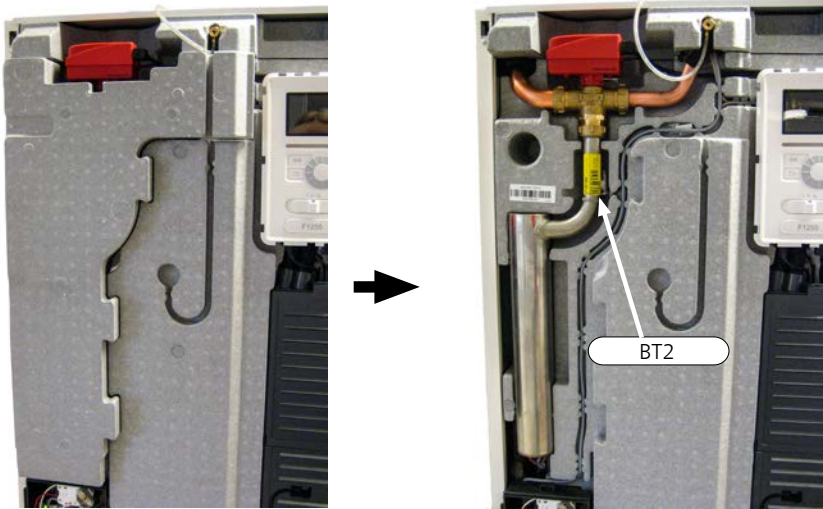

4 Ensure that the heat pump is unpowered before continuing.

5 Disconnect the 2 blue cables, the 2 white and the 3 brown cables from the terminal block X3 and X7 on (AA1).

6 Pull out the two bulbs from the immersion heater.

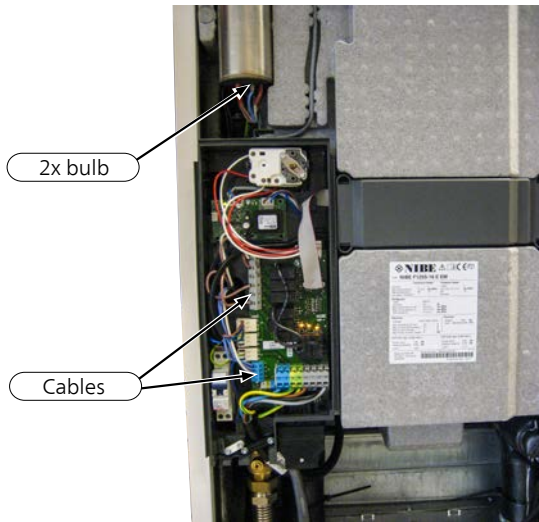

7 Disconnect the immersion heater at the marked couplings.

8 Remove the box for the immersion heater circuit board (AA1).

9 Remove the immersion heater.

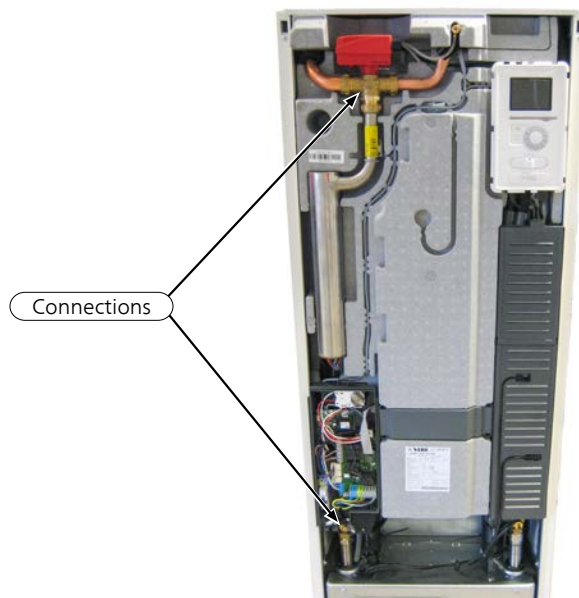

Reversing valve (QN10)

1 Drain the heating medium system.

2 Remove the plastic cap over (AA1) using a screwdriver.



3 Remove the insulation.

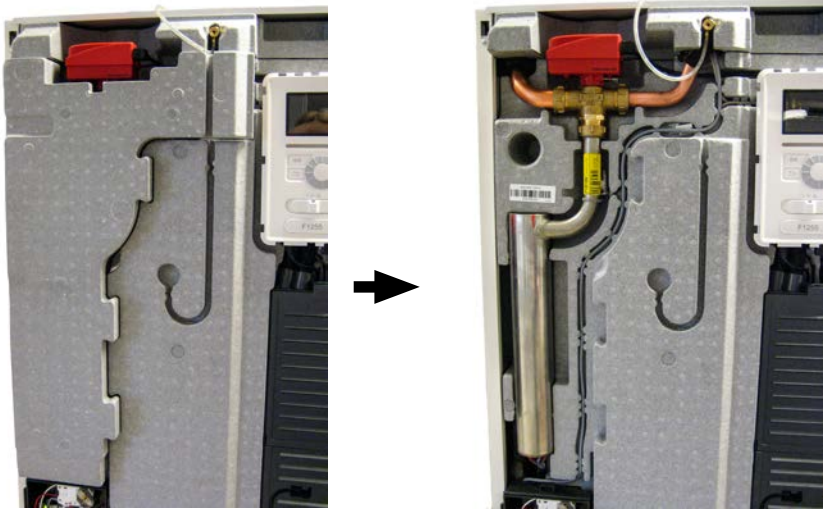

4 Remove the switch on the actuator.

5 Remove the pin and re-
move the actuator.

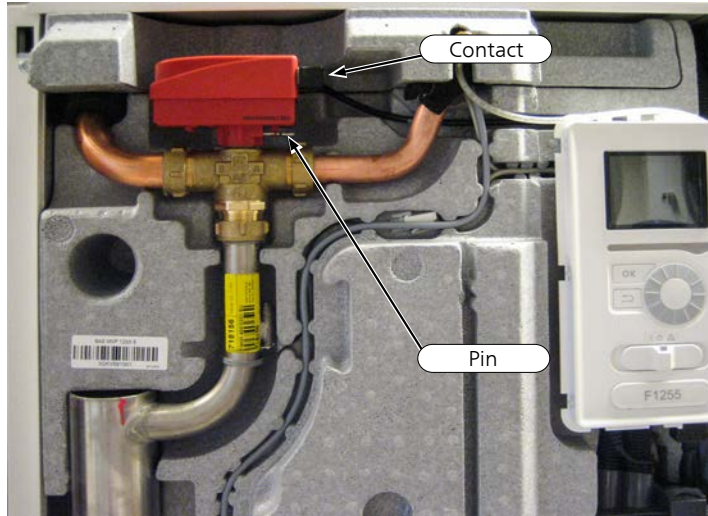

6 Disconnect and remove the
three way valve.

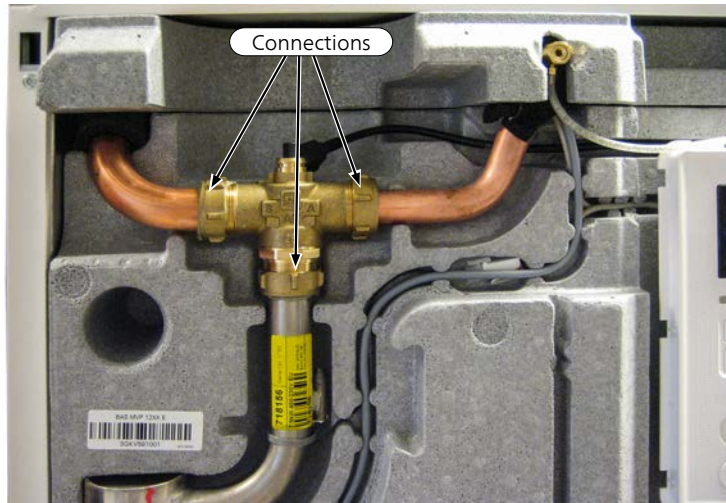

Heating medium pump (GP1)

- 1** Drain the heating medium system.
- 2** Slacken off 2 x screws.
- 3** Remove the front hatch on the cooling module.
- 4** Close the shut-off valves QM31 and QM32
- 5** Drain the heating circuit by QM1



- 6** Remove the electric switch on the circulation pump.
- 7** Remove the switch for the control cable on the joint board. AA100
- 8** Disconnect and remove the circulation pump.

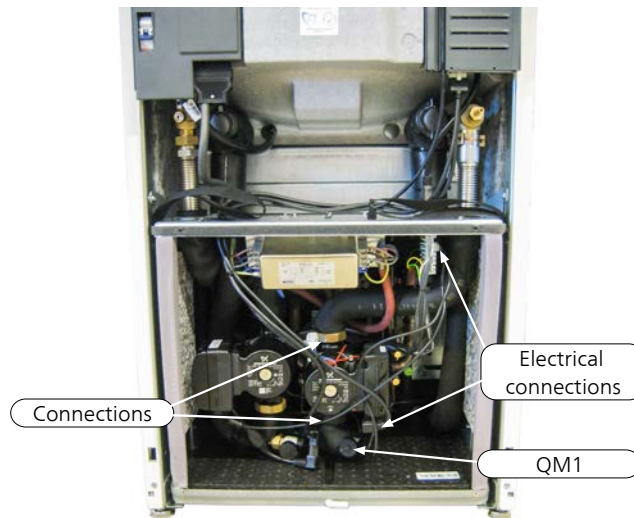

Brine pump (GP2)

- 1 Slacken off 2 x screws.
- 2 Remove the front hatch on the cooling module.
- 3 Close the shut-off valves (QM33) and (QM34).
- 4 Drain the brine system via drain valve QM2.



- 5 Remove the electric switch on the circulation pump.
- 6 Remove the switch for the control cable on the joint board. AA100.
- 7 Disconnect and remove the circulation pump.

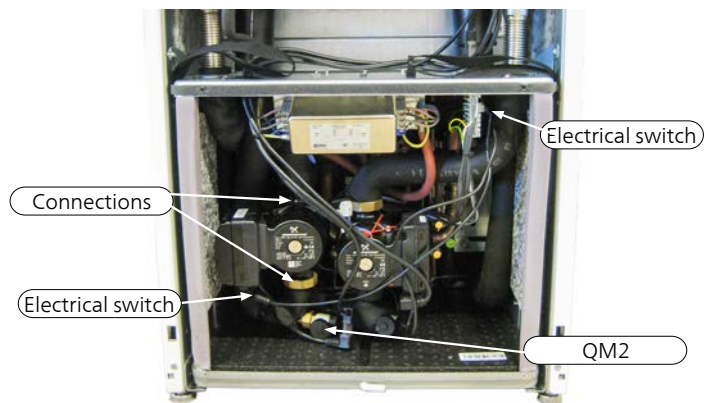

source

Re-

Circuit board and electronics

Immersion heater card (AA1)

1 Remove the plastic cover over the electronics box.



2 Disconnect the cables and screws holding the card in position.

3 Remove the immersion heater card (.AA1).

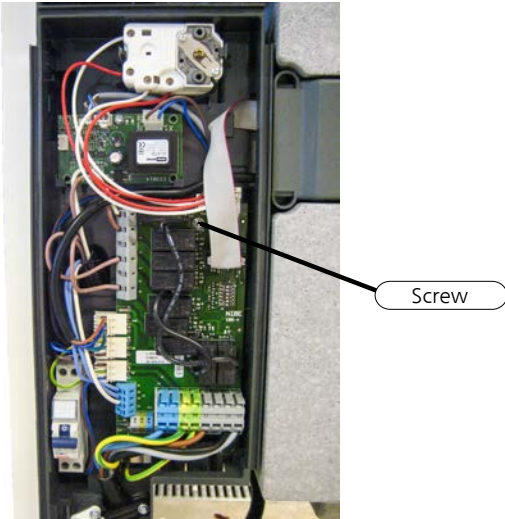

Base card (AA2)

1 Remove the plastic cover over (AA3. See page 56.

2 Remove the cable that is connected through the cover in front of (AA2).

3 Remove the cover by pressing the catch down at the upper edge of the cover.

4 Remove the plastic cover over (AA2).

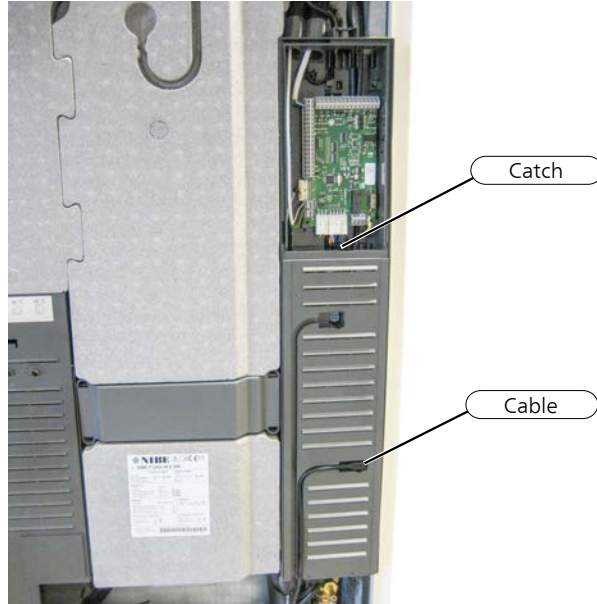

5 Disconnect the cables and screws holding the board in position.

6 Remove the base board (AA2).

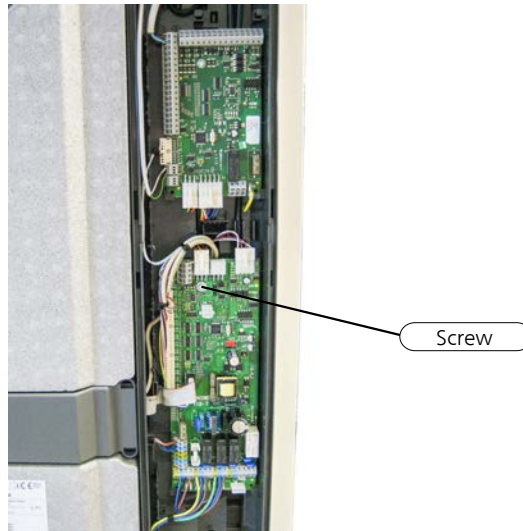

Input circuit board (AA3)

1 Remove the plastic cover over (AA3). See page 56.

2 Disconnect the cables and screws holding the card in position.

3 Remove the input card (AA3).



Screw

Display unit (AA4)

1 Remove the communication cable and any Ethernet connection at the lower edge of the display unit.

2 Press the catch on the upper rear side of the display unit towards you.

3 Remove the display unit.

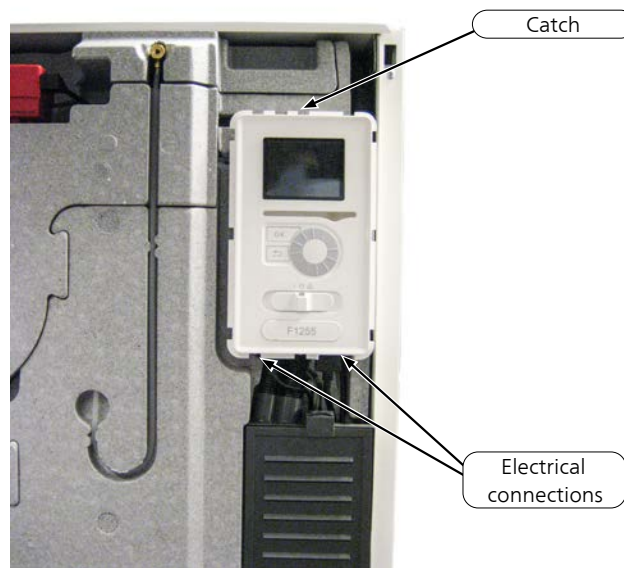

Inverter (QA40)

- 1 Remove the cooling module according to the instruction on page ??
- 2 Slacken off 12 screws.
- 3 Remove the top cover from the cooling module.

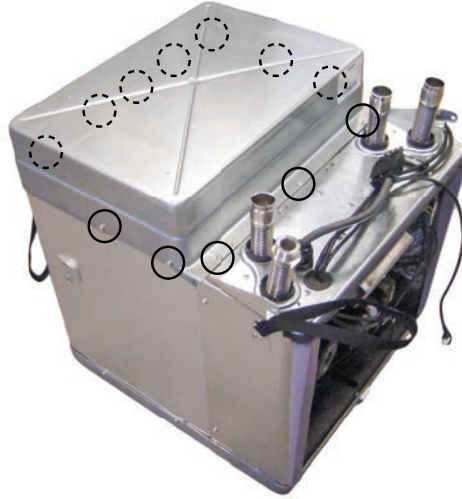

- 4 Slacken off 9 screws.
- 5 Remove the left/rear side panel on the cooling module.



- 6** Remove cables and connectors.
- 7** Slacken off 4 screws.
- 8** Remove the inverter.

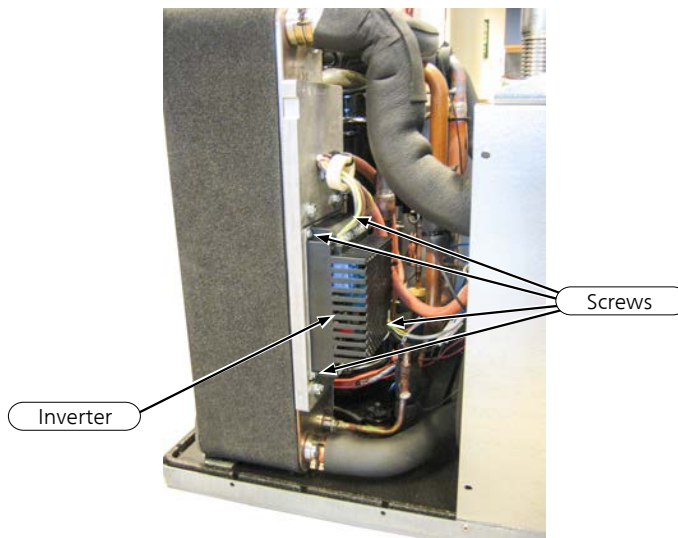

- 9** Scrape the paste from the aluminium plate using, for example, a plastic ice scraper.
- 10** Apply 6 g of silicone paste to the new inverter's heat releasing plate (as illustrated), and spread it evenly across the marked area using, for example, an ice scraper.
- 11** Install the inverter, 4 screws.
- 12** Wait 5 minutes for the silicone paste to flow out and distribute itself better.
- 13** Remove the inverter, 4 screws, and check that the paste has smoothed out the irregularities, if not, add more paste.
- 14** Reinstall the inverter, 4 screws.
- 15** Wipe off any excess paste.

Yta som behöver kiselpasta

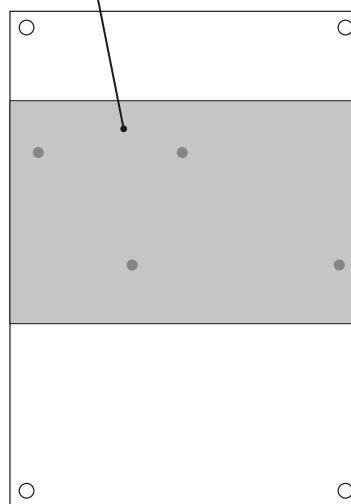

16 Install the cables from the EMC filter to terminal block X1 on the inverter as follows:

- - Connect grey cable (0069) to L3.
- - Connect brown cable (0067) to L1.
- - Connect black cable (0068) to L2.
- - Connect grey cable (0069) to L3.

17 Install the cables from the compressor to terminal block X2 on the inverter as follows:

- - Connect brown cable (088U) to U.
- - Connect black cable (089V) to V.
- - Connect grey cable (090W) to W.

18 Install the modular cable (communication) to terminal block X3.

Temperature sensor

Mounting

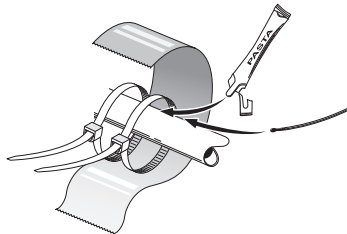

Install the temperature sensor with cable ties with the heat conducting paste and aluminium tape.

Then insulate with supplied insulation tape.

8 Technical data

Electrical wiring diagram

F1255

1x230V F1155-6/F1255-6

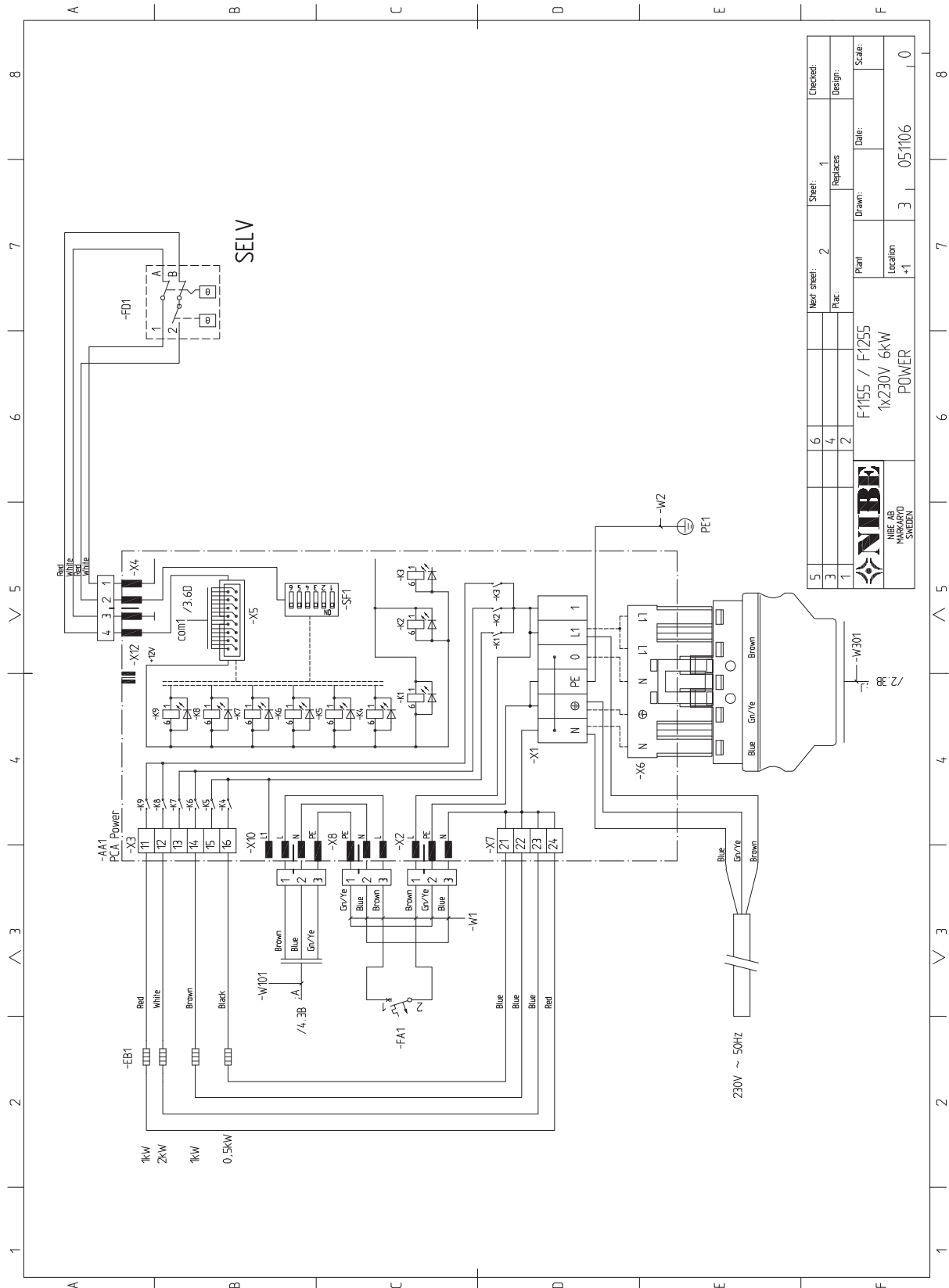

5	Next sheet:	2	Sheet:	1	Checked:
3	Replaces:		Design:		
1	Drawn:	2	Plant:	F1155 / F1255	Date:
	Location:	+1	Scale:	0	
 NIBE AB MAXIMILIANSGÄTTEN					
F1155 / F1255 1x230V 6kW POWER					
Date: 05/106					

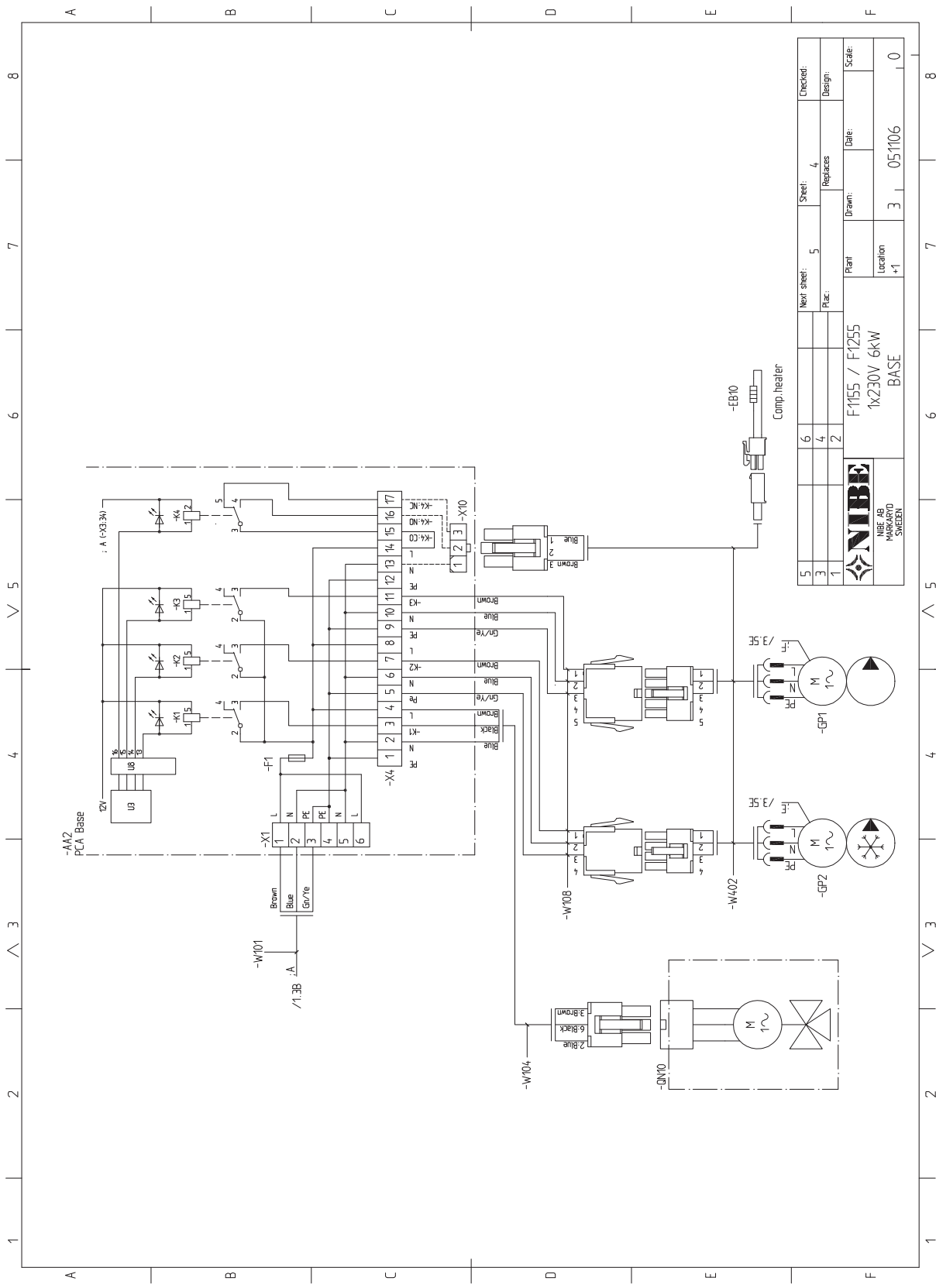

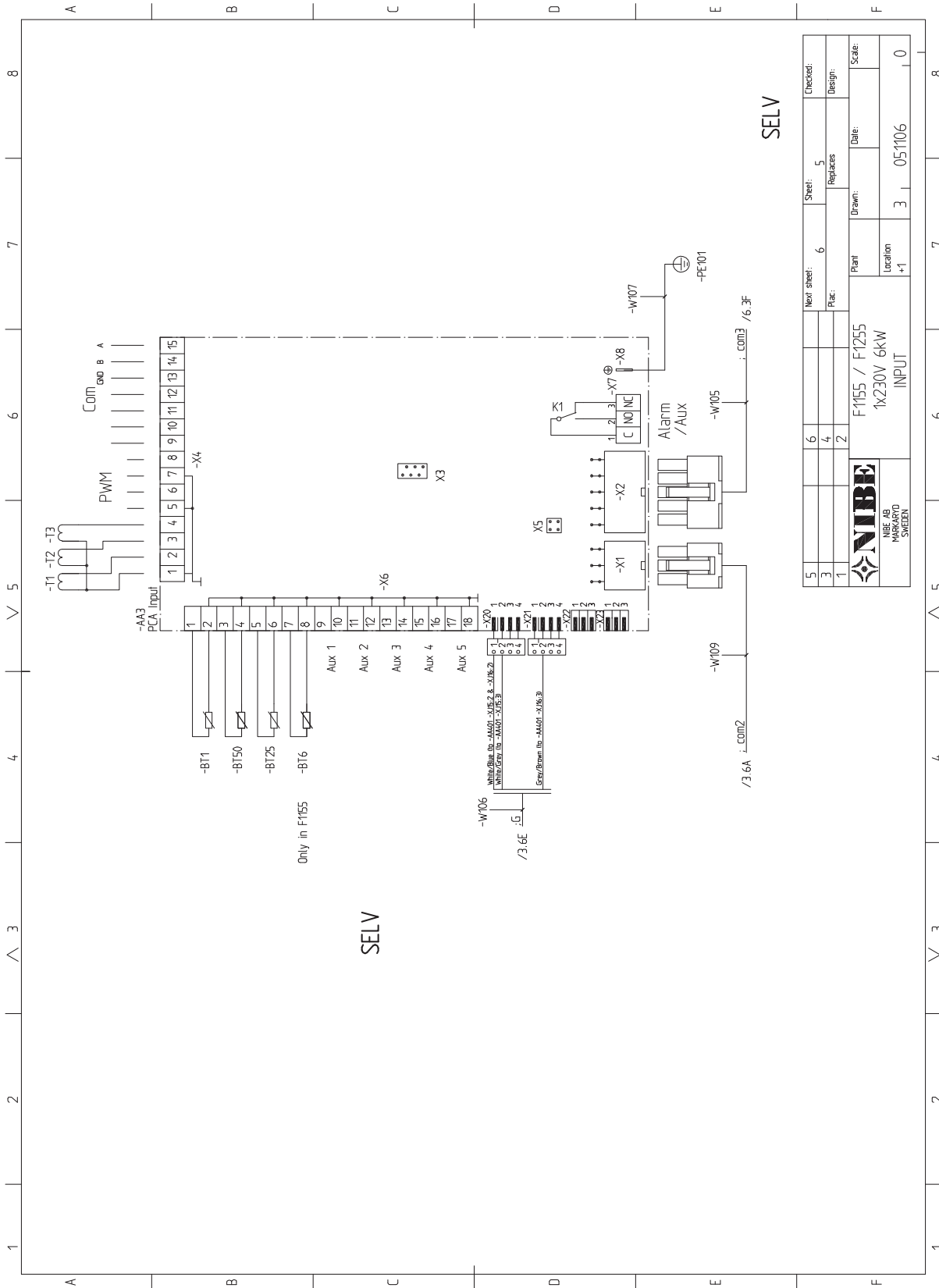



SELV

5	Next sheet:	6	Sheet:	5	Checked:	
3	Replaces:		Replaces:	5	Design:	
1	Plant:	F1155 / F1255		Drawn:	Date:	Scale:
	Location:	1x230V 6kW		3	05/1106	0
	INPUT					

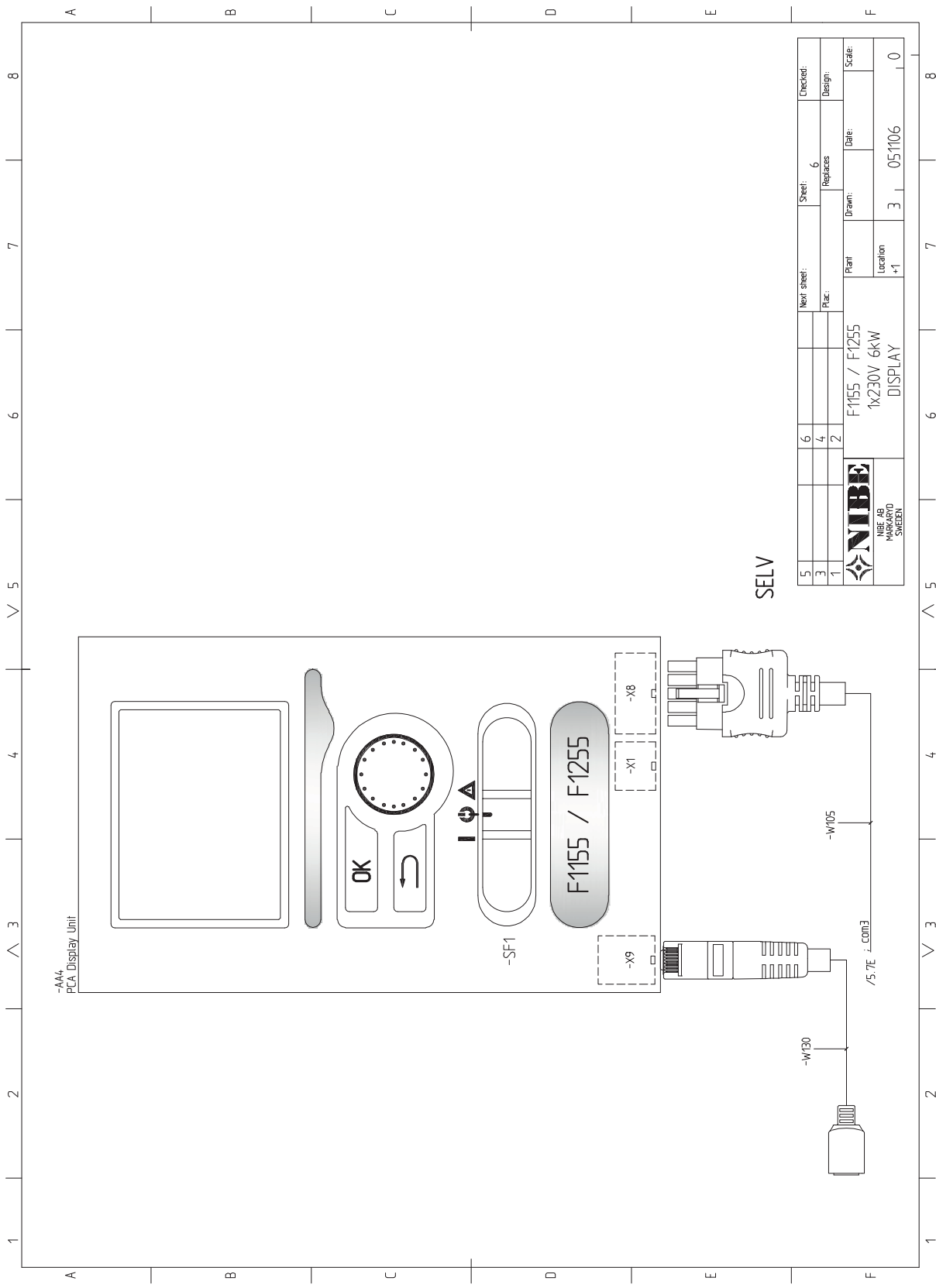

NIBE AB
NIBE AB
SWEDEN



5	6	Next sheet:	Sheet:	Checked:
3	4	Plac.:	6	Design:
1	2	Plant:	Replaces:	Scale:
 NIBE AB HÄRNASAND SWEDEN		F1155 / F1255	Drawn:	Date:
		1x230V 6KW DISPLAY	Location +1	3 05-1106
				0

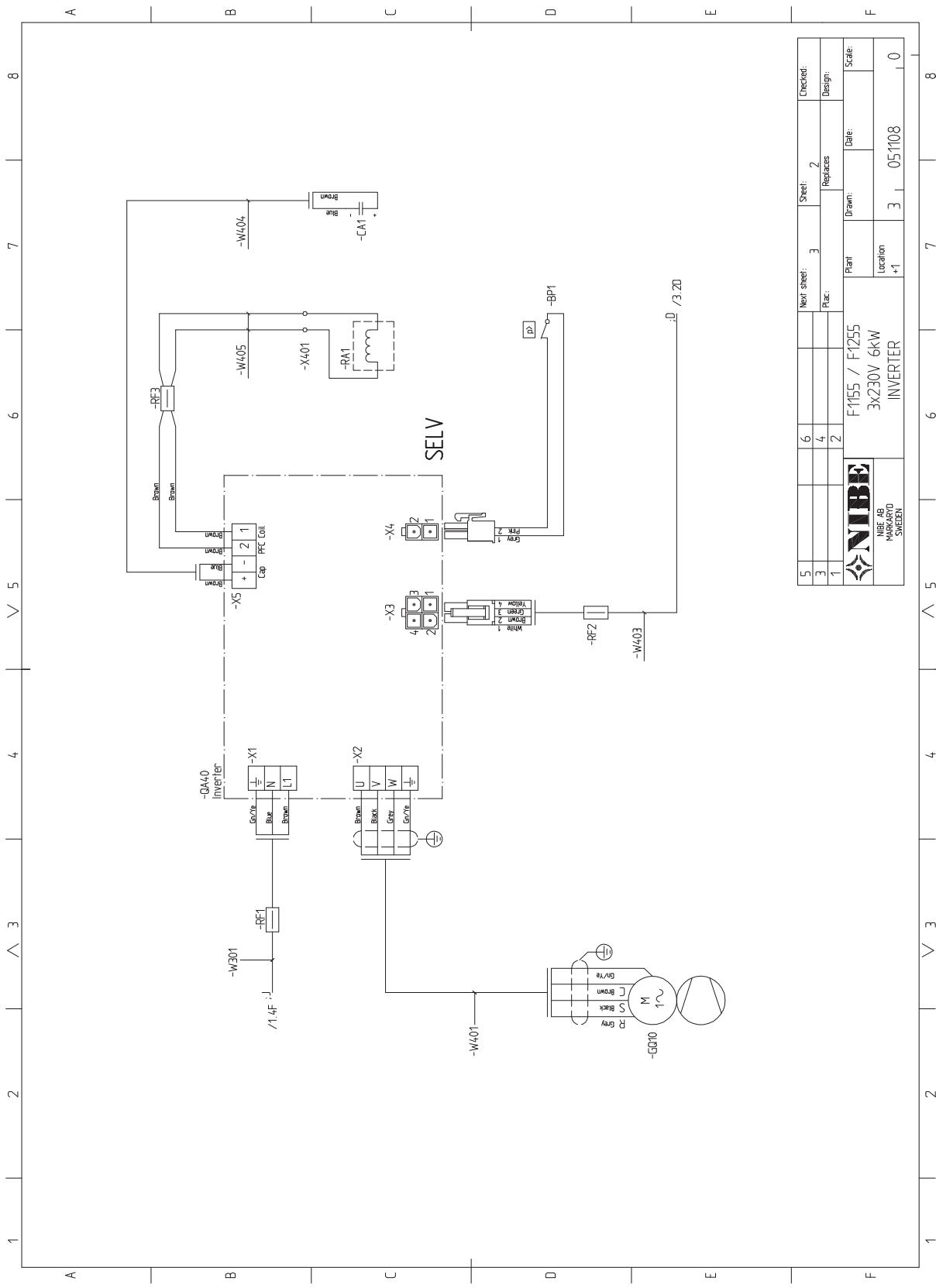

5		6		Next sheet:	3	Sheet:	2	Checked:	
3		4		Replaces:		Design:			
1		2		Plant:	F1155 / F1255	Date:			
				Location:	3x230V 6kW	Drawn:			
					INVERTER	Location	+1	3	05-1108
						Scale:			0



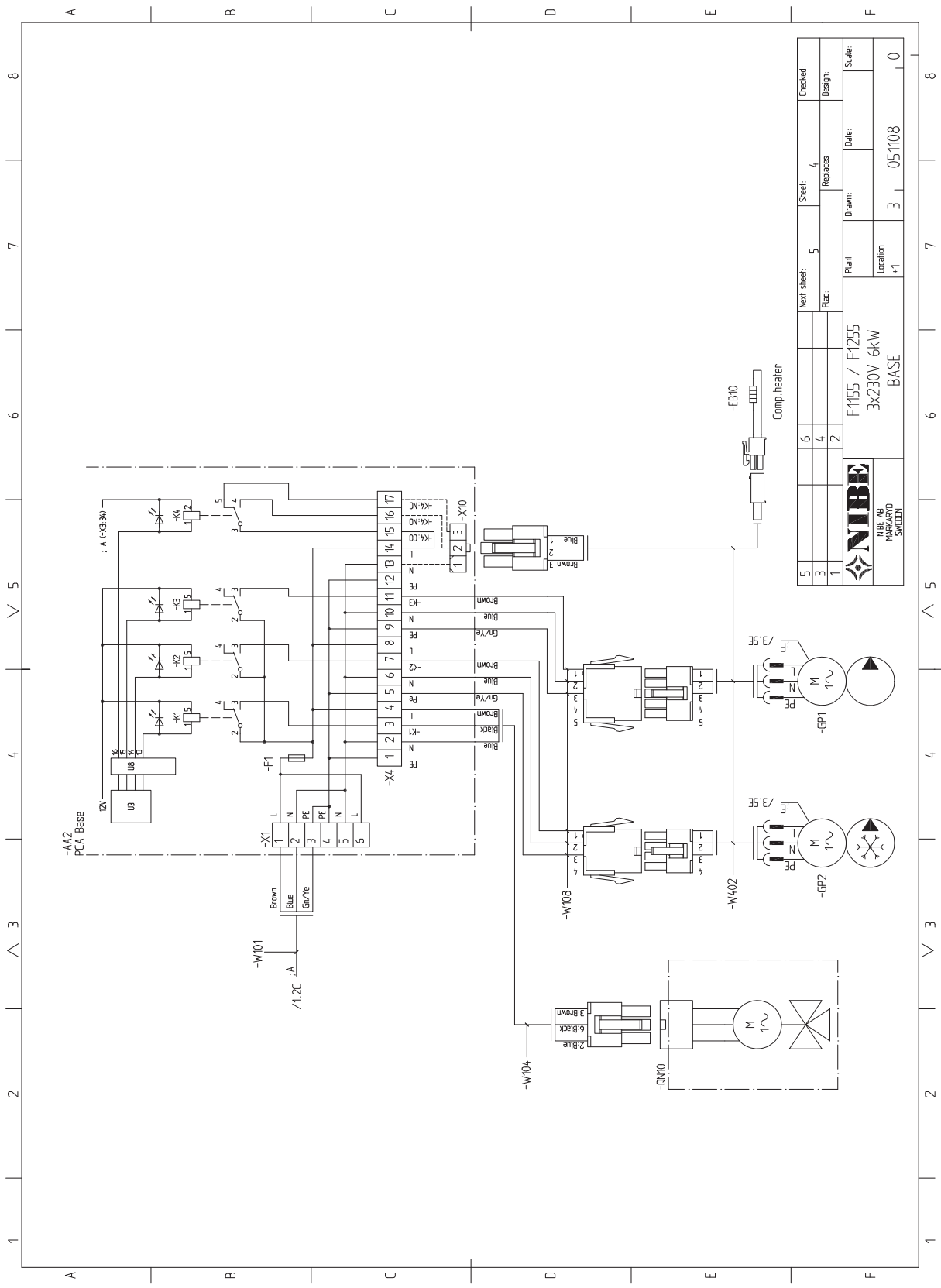

5	6	Next sheet:	5	Sheet:	4	Checked:
3	4	Replaces:	2	Design:		
1	2	Plant:	F1155 / F1255	Drawn:		Scale:
		Location:	3X230V 6kW	Date:		
		BASE		3	05-1108	0



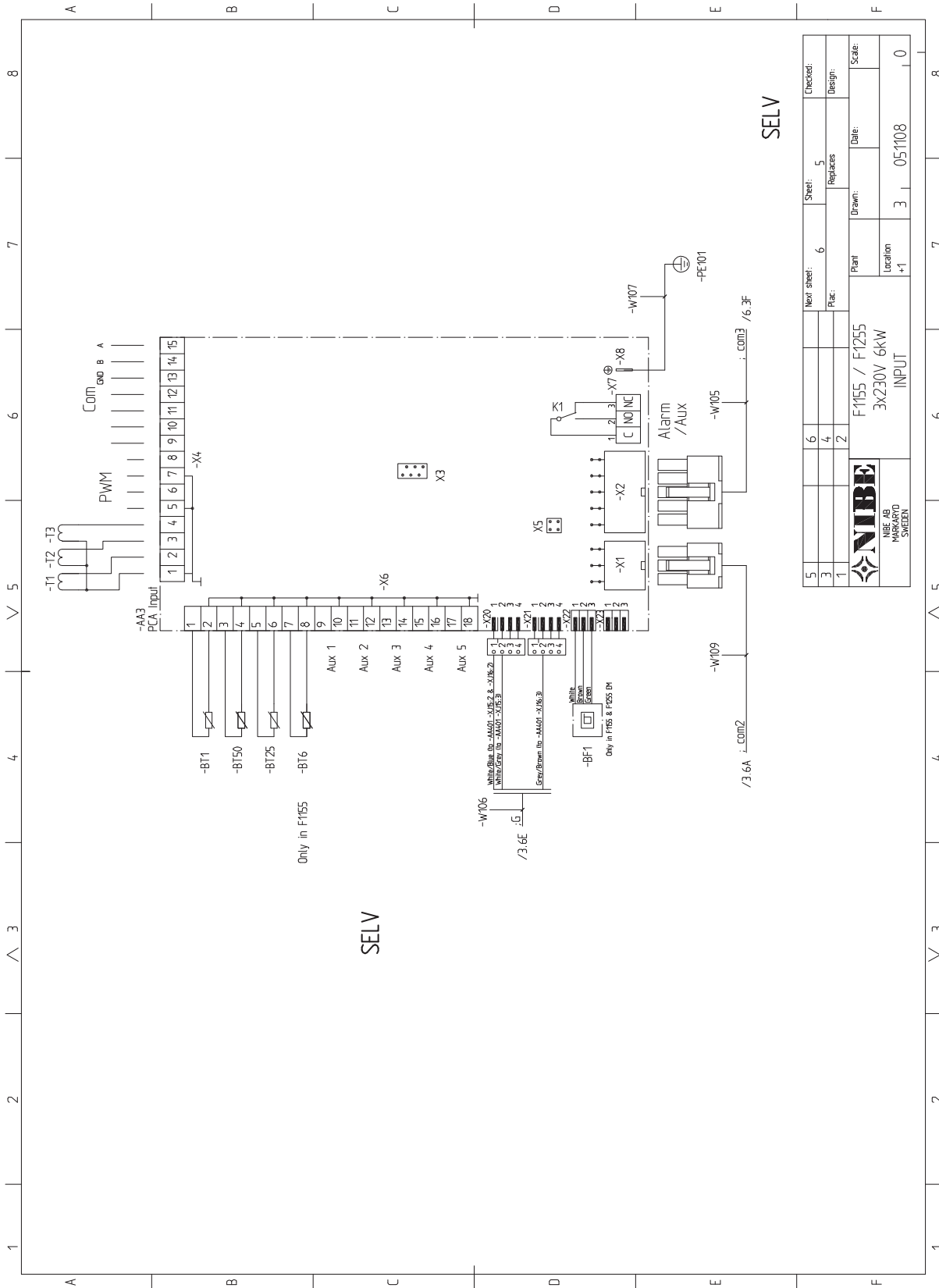



SELV

5	Next sheet:	6	Sheet:	5	Checked:	
3	Replaces:		Replaces:	5	Design:	
1	Plant:	F1155 / F1255		Drawn:	Date:	Scale:
	Location:	3x230V 6kW		3	05/1108	0
	INPUT					

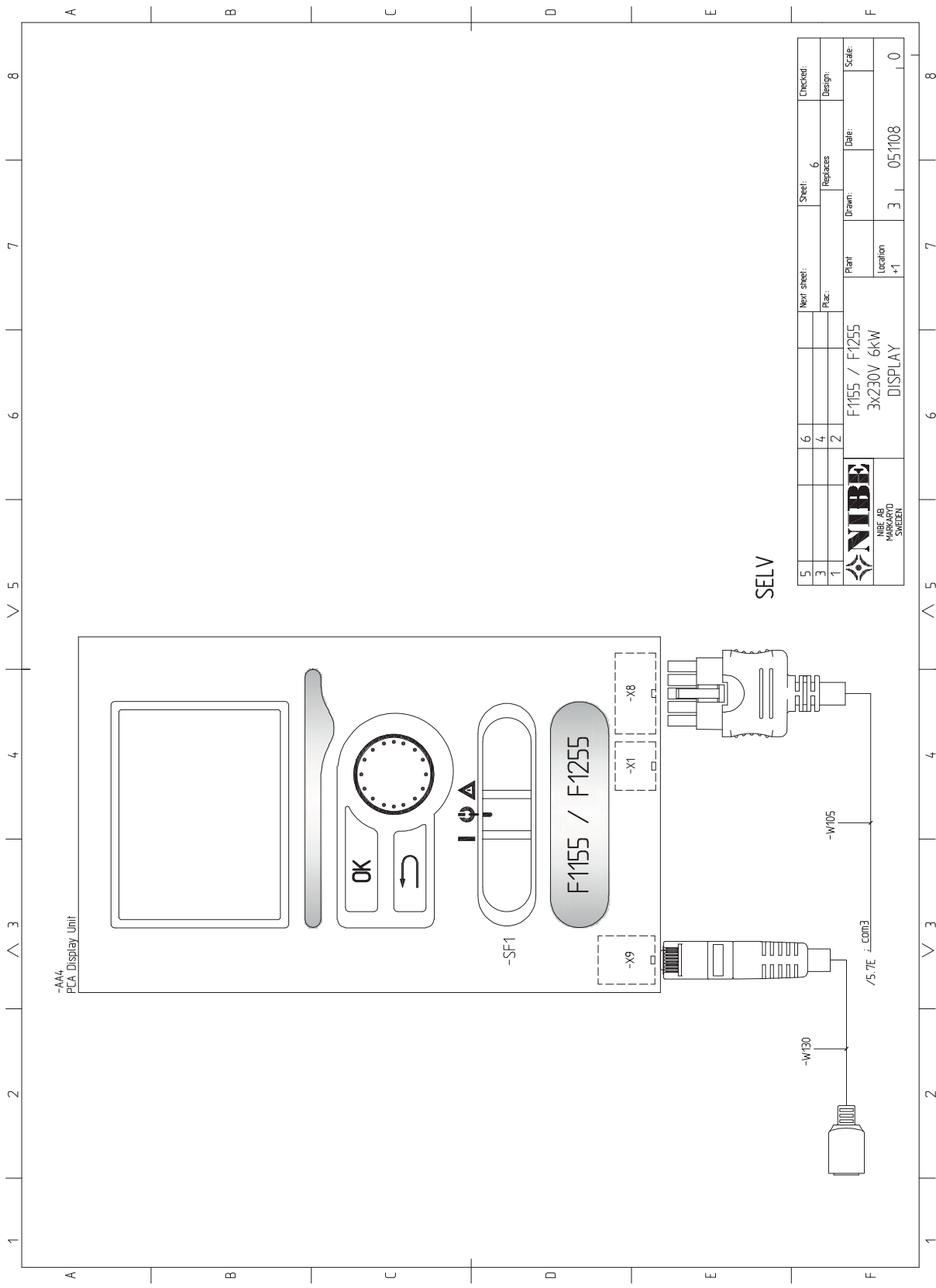

NIBE AB
NIBE AB
SWEDEN



5		6	Next sheet:	Sheet:	6	Checked:
3		4	Replaces:	Replaces		Design:
1		2	Plant:	Drawn:	Date:	Scale:
 NIBE AB HÄRNASAND SWEDEN			F1155 / F1255			
			3x230V 6kW	Plant	Location	3
			DISPLAY	+1		

3x400V F1155-6/F1255-6

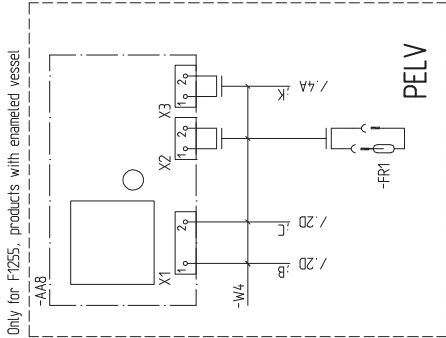
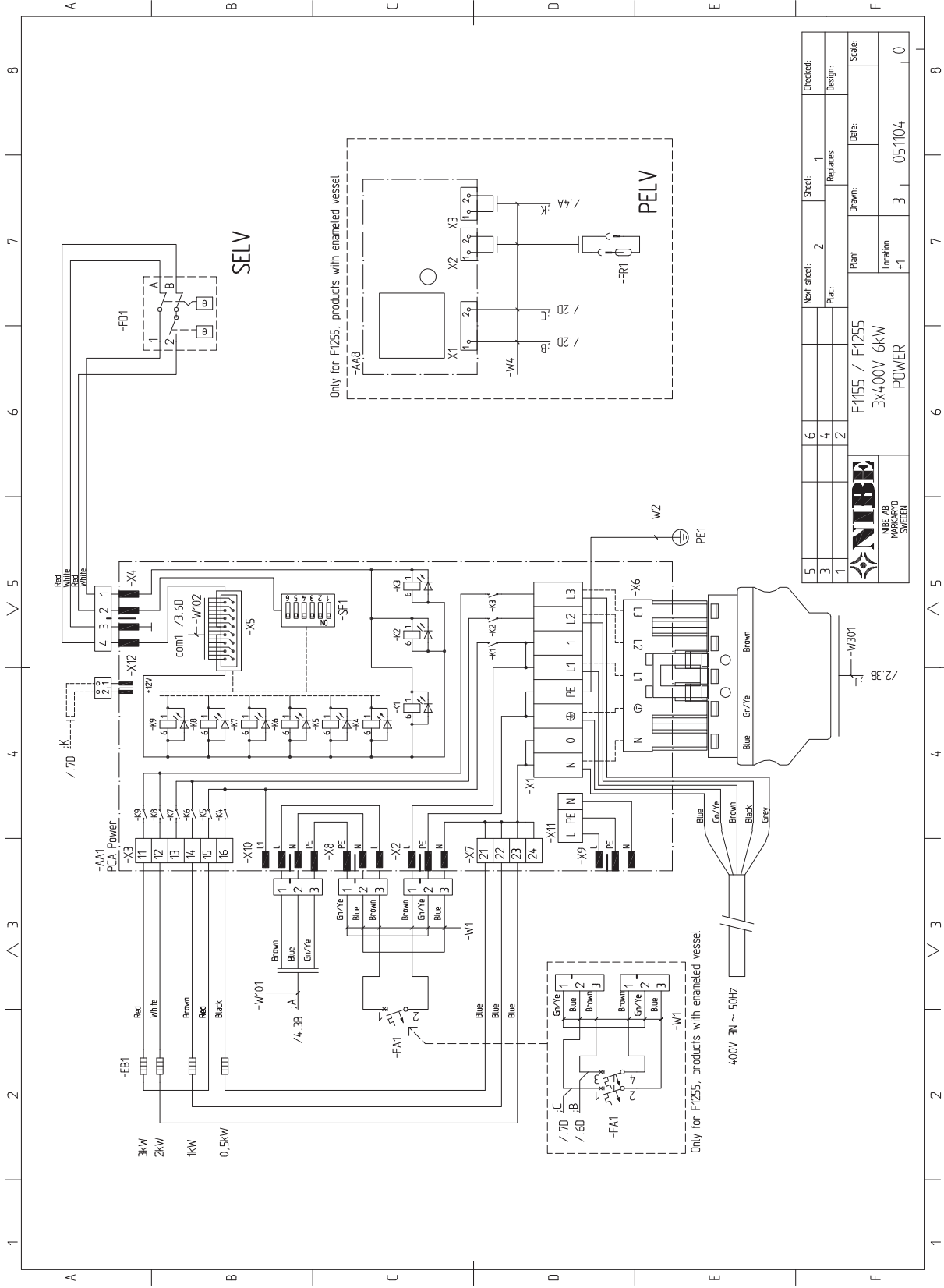

5	Next sheet:	2	Sheet:	1	Checked:	
3	Replaces:	4	Design:			
1	Plant:	F1155 / F1255		Date:		Scale:
	Location:	3x400V 6kW		Drawn:		
	POWER	+1	3	05/10/04		0



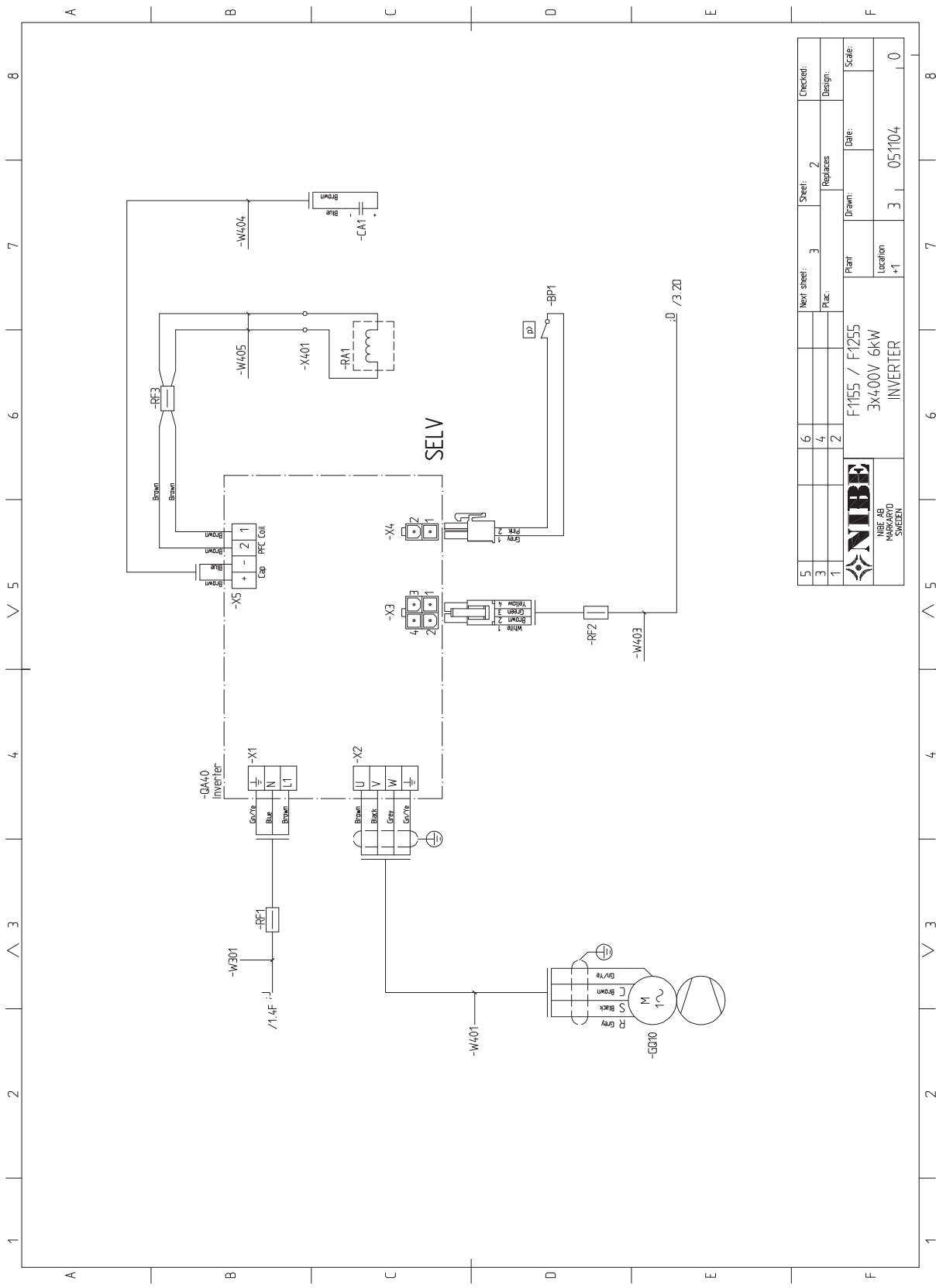

5		6		Next sheet:	3	Sheet:	2	Checked:	
3		4		Replaces:		Design:			
1		2		Plant:	F1155 / F1255	Drawn:		Date:	
				Location:	3X400V 6kW				Scale:
					INVERTER				0
 NIBE AB HÅRSKÅRDBY SWEDEN									
				Location:	+1				

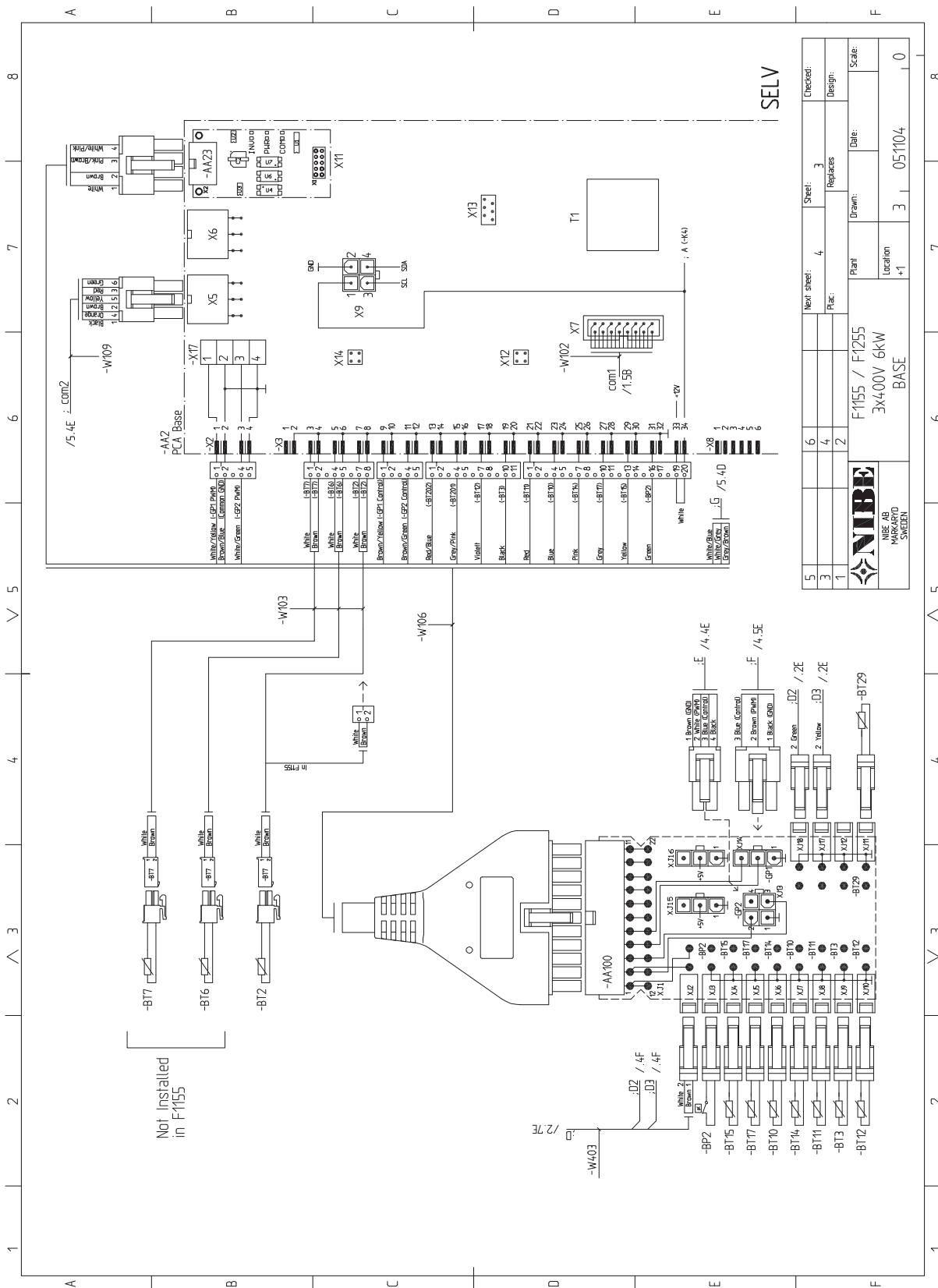

SELV

5	6	Next sheet:	4	Sheet:	3	Checked:	
3	4	Replaces:		Design:			
1	2	Plant:	F155 / F1255		Drawn:	Date:	Scale:
		Location:	3x400V 6kW		3	05/11/04	1
			BASE				0



NIBE AB
MÖRBYLÅN
SWEDEN

Not installed
in F155

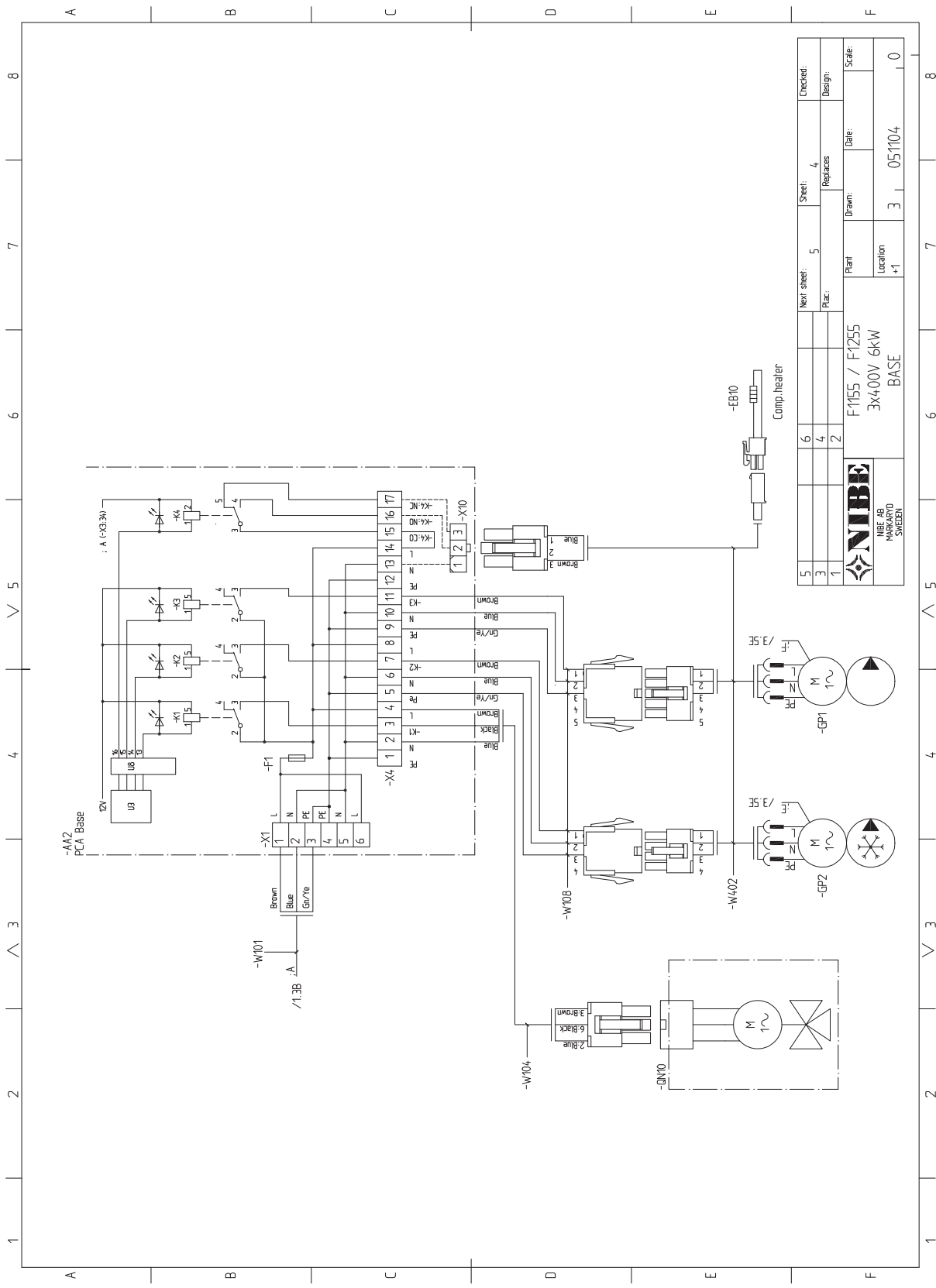

5	Next sheet:	5	Sheet:	4	Checked:
3	Replaces:	2	Design:		
1	Plant:	F1155 / F1255	Drawn:		Scale:
	Location:	3x400V 6kW	Date:		
		BASE	3	05/1104	0



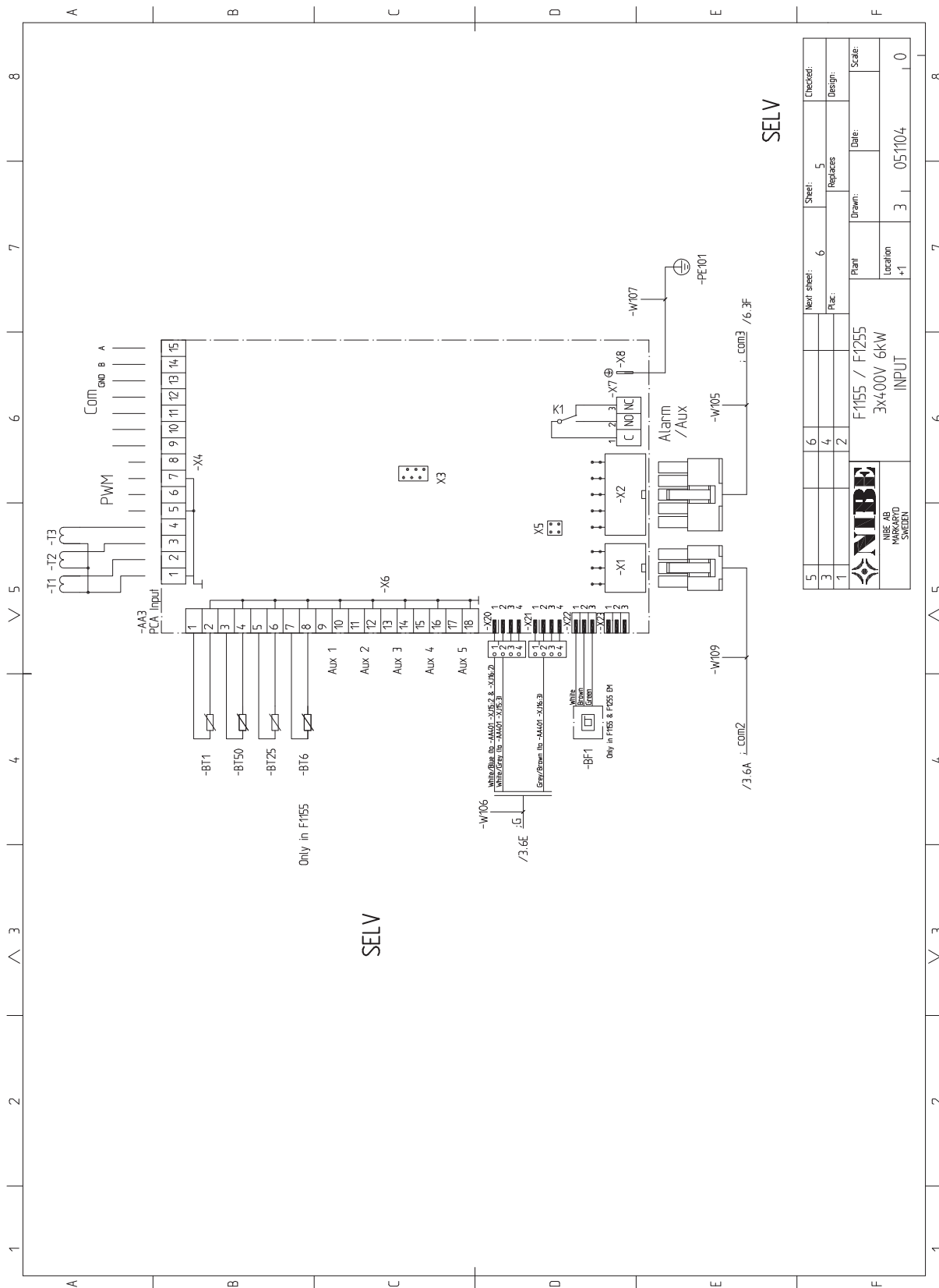

SELV

5	Next sheet:	6	Sheet:	5	Checked:
3	Replaces:		Replaces:	5	Design:
1	Plant:	F1155 / F1255	Drawn:		Scale:
	Location:	3x4-00V 6kW	Date:		
		INPUT		3	05/11/04
					0



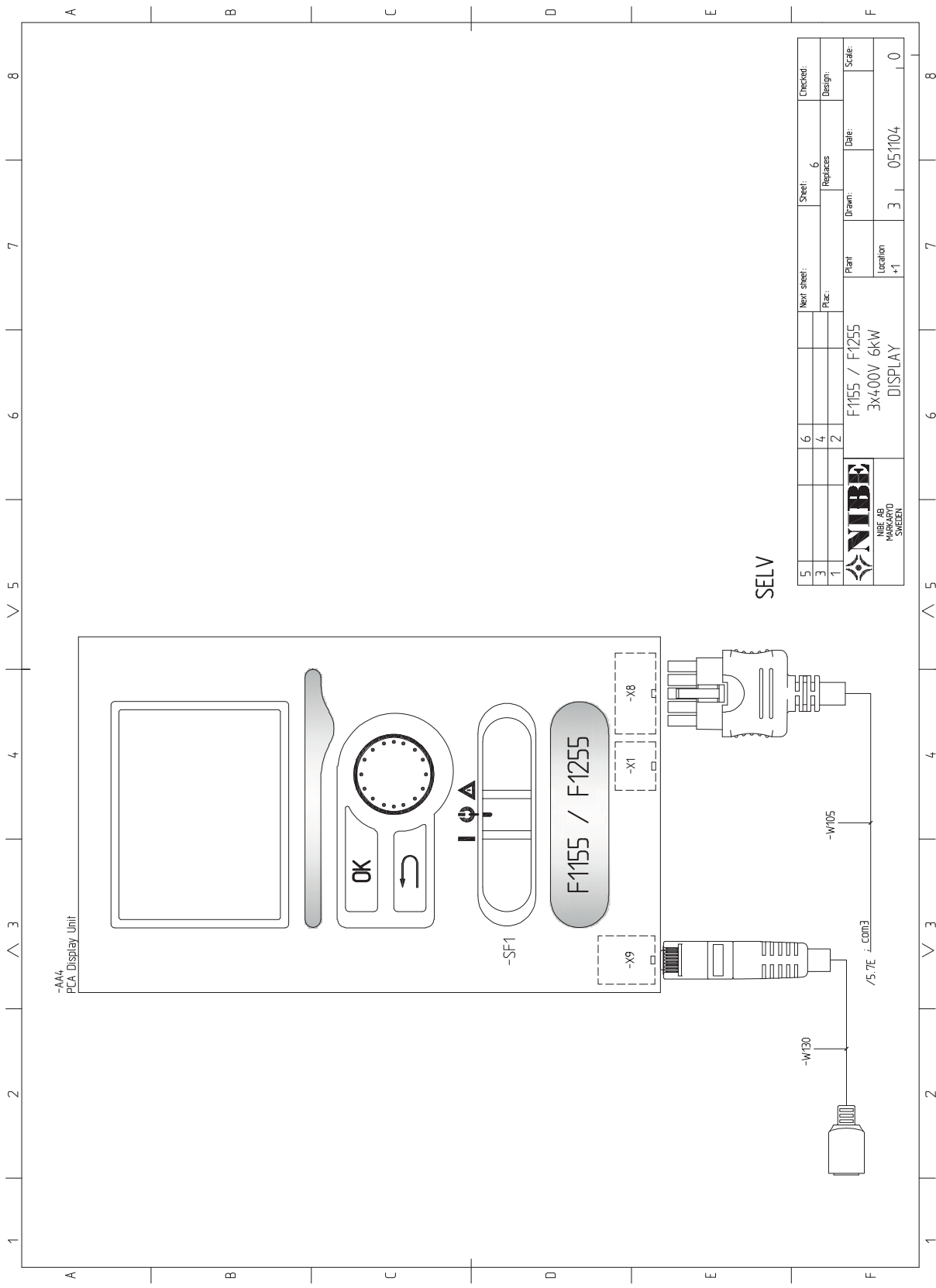

SELV

5		6	Next sheet:	Sheet:	6	Checked:
3		4	Plac.:	Replaces		Design:
1		2		Plant:	F1155 / F1255	Date:
				Location:	3x400V 6kW	Scale:
					DISPLAY	0
					+1	
					3	05/10/04



3x400V F1155-16/F1255-16

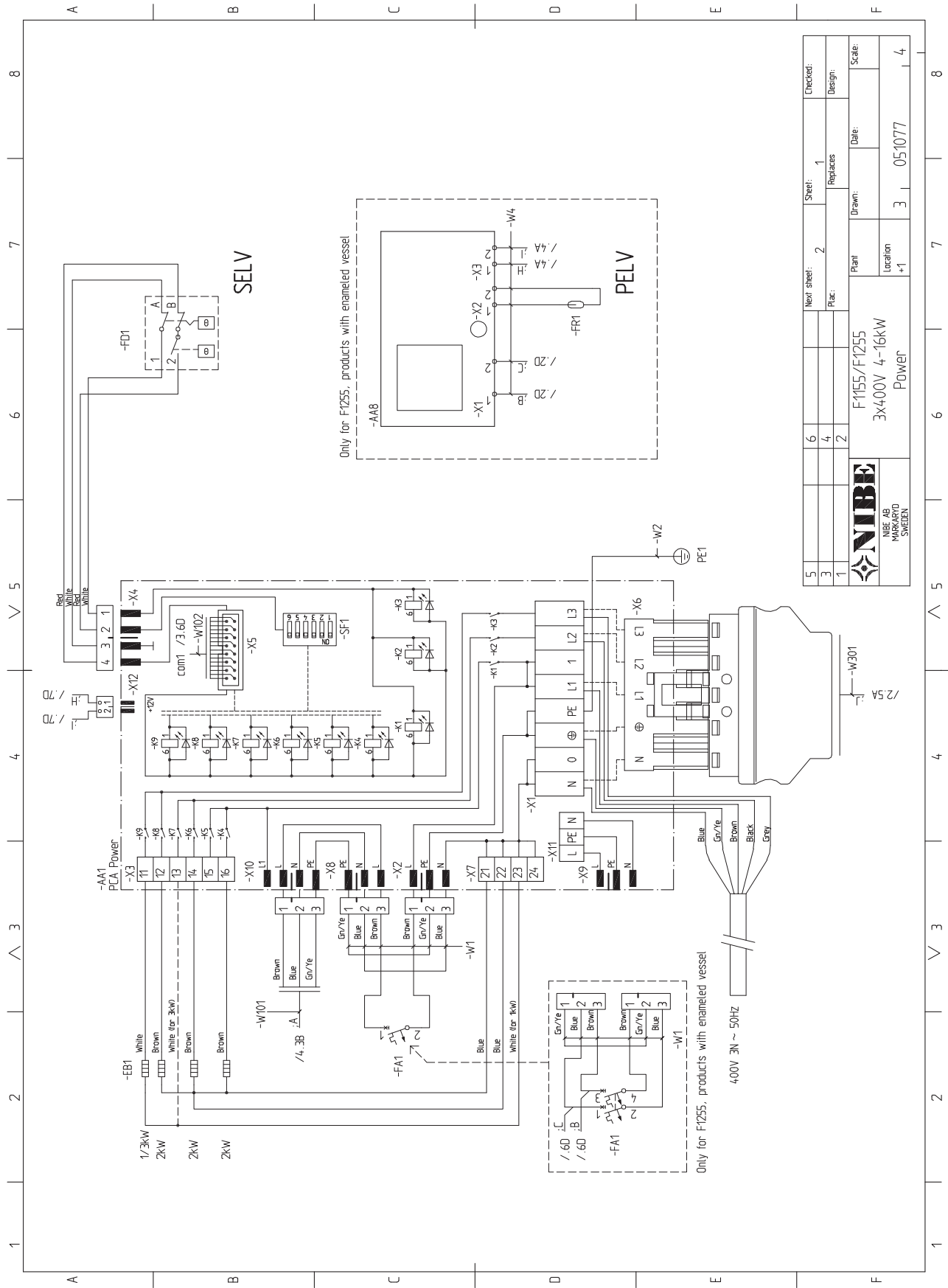

5	Next sheet:	2	Sheet:	1	Checked:
3	Plac.:	2	Replaces:		Design:
1					Scale:
Plant:			Date:		
F1155/F1255			05/10/77		
3x400V 4~16kW			Location		
POWER			*1		
NIBE AB			3		
MÖRNSÅS			4		
SWELEN					

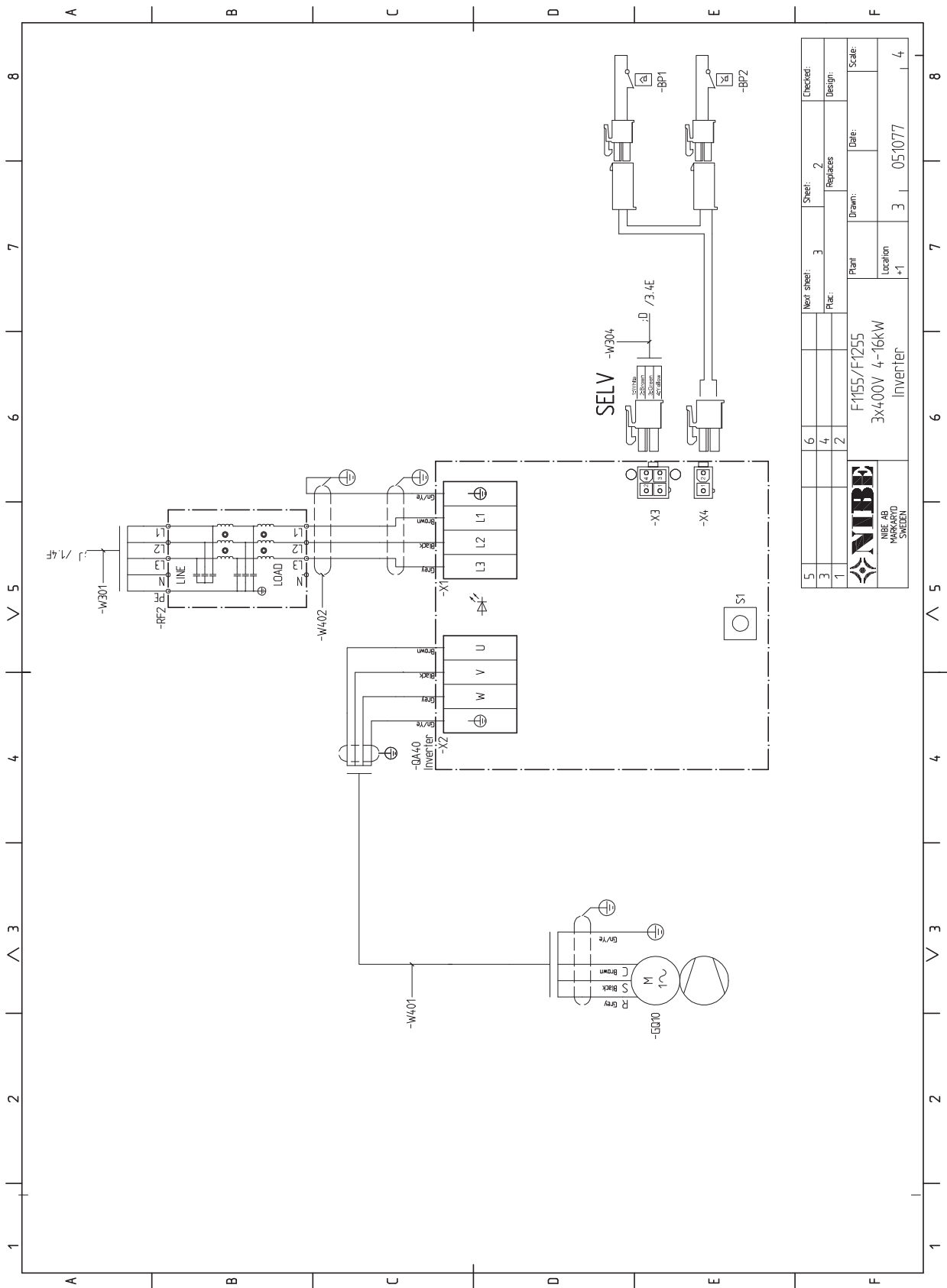

5		Next sheet:	3	Sheet:	2	Checked:		
3		Plac.:		Replaces:		Design:		
1						Scale:		
 NIBE AB INDUSTRIAL SWEDEN		Plant:	F1155/F1255		Drawn:		Date:	
		Location:	3X400V 4-16kW Inverter			3	051077	4

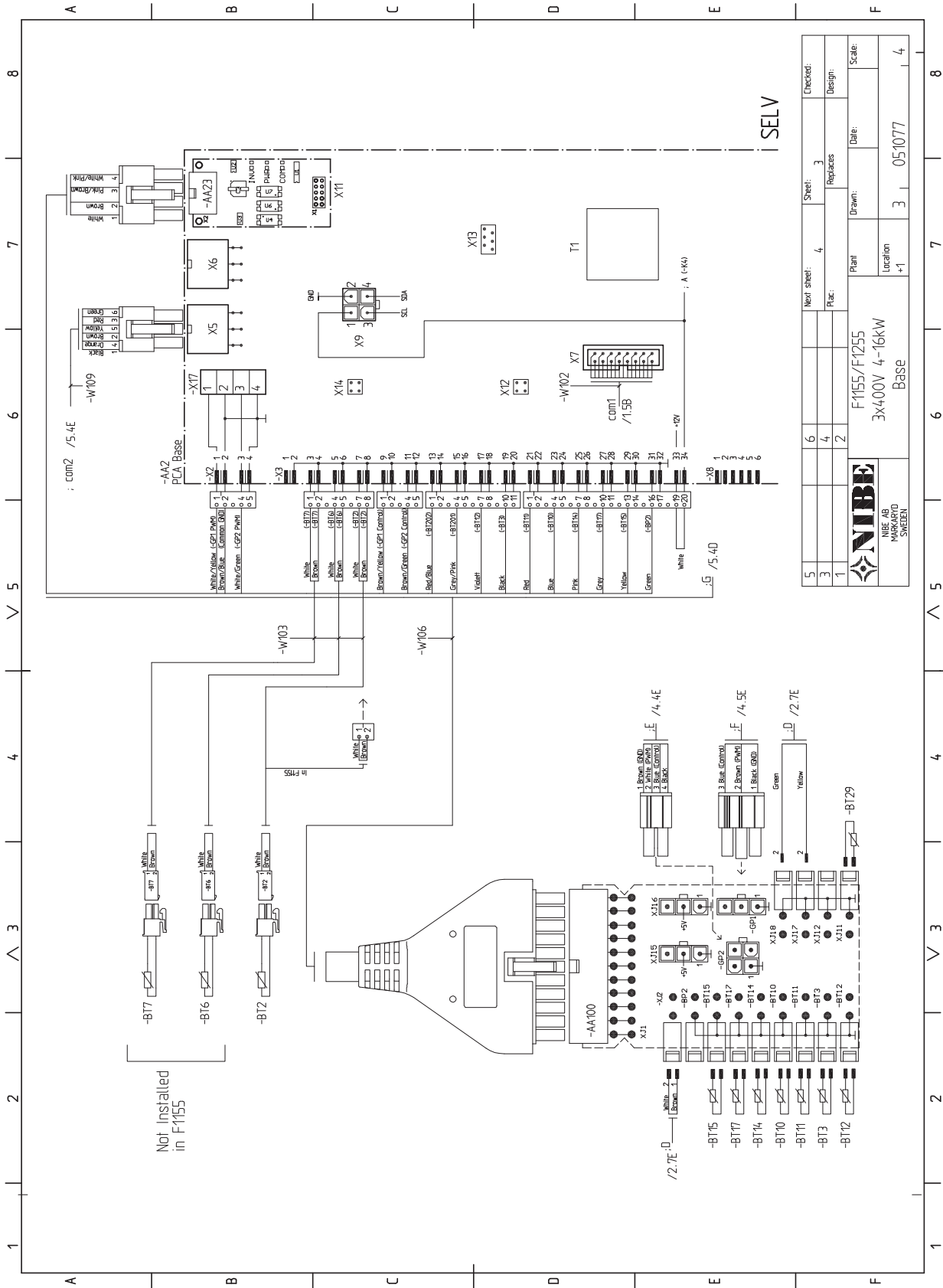

Not installed in F1255

SELV

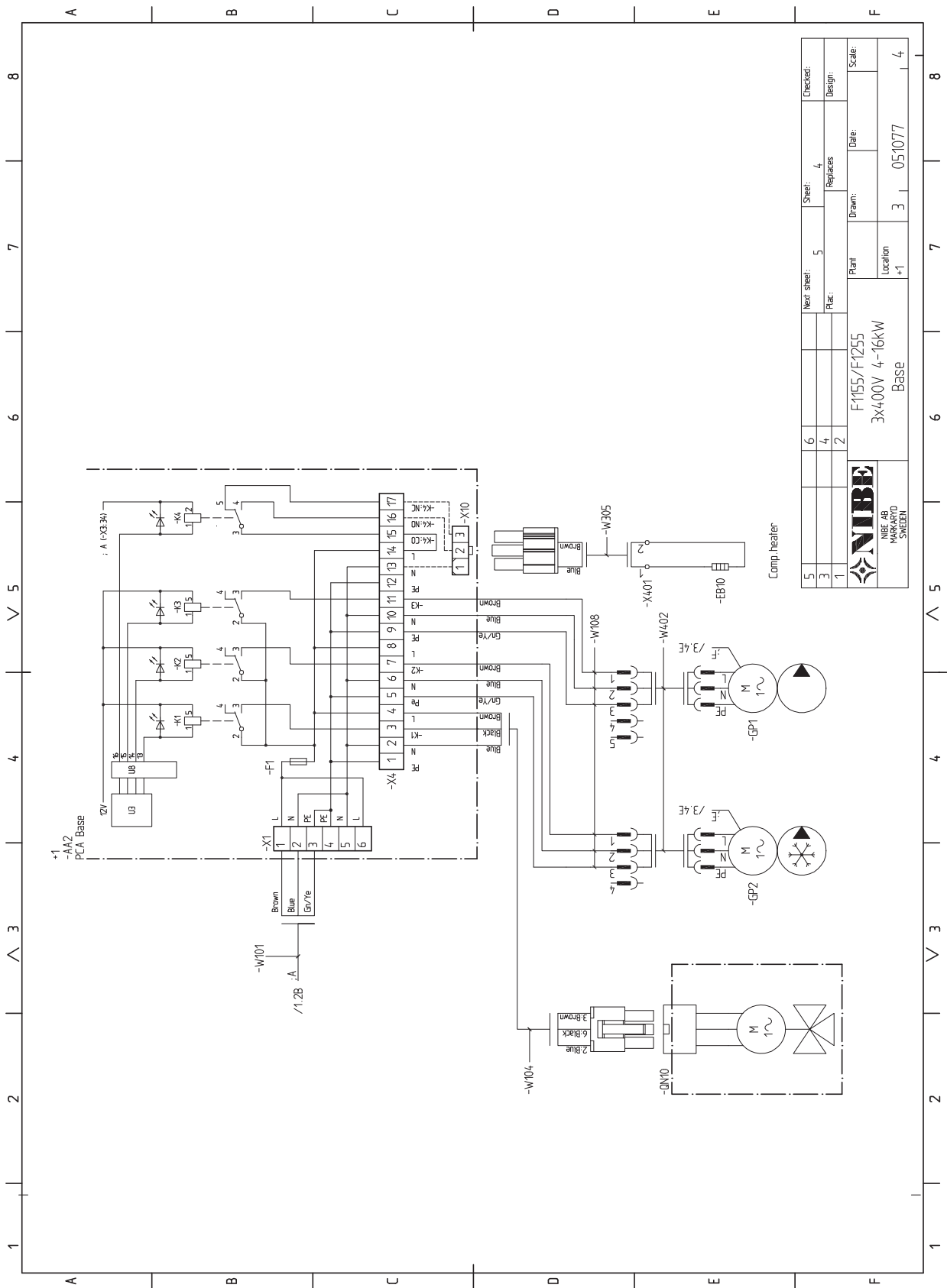

5	6	Next sheet: 5	Sheet: 4	Checked:
3	4	Plac: 2	Replaces:	Design:
1	2	Plant: F155/F1255	Drawn: 3	Date: 051077
		Location: +1	Scale: 4	



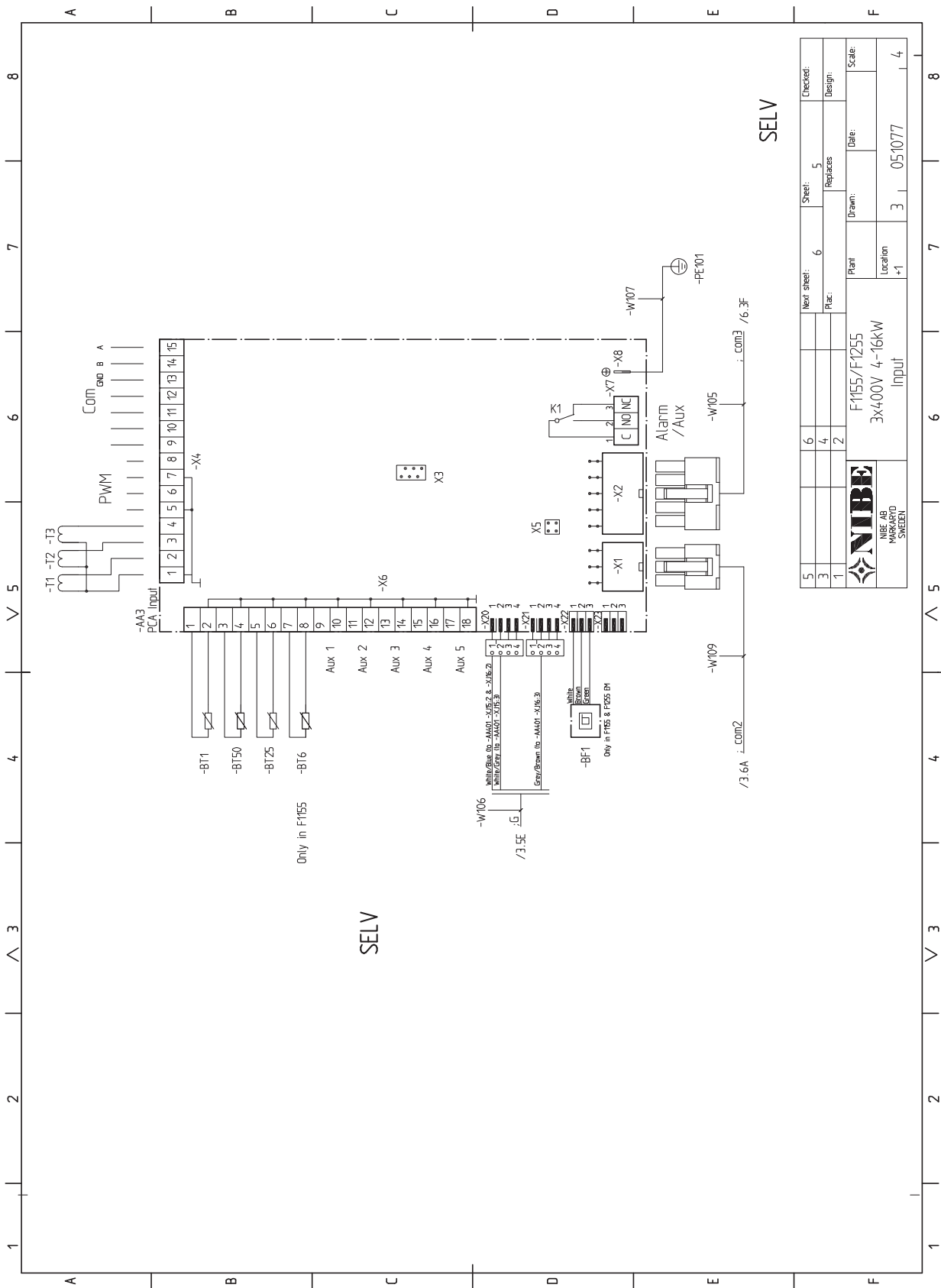

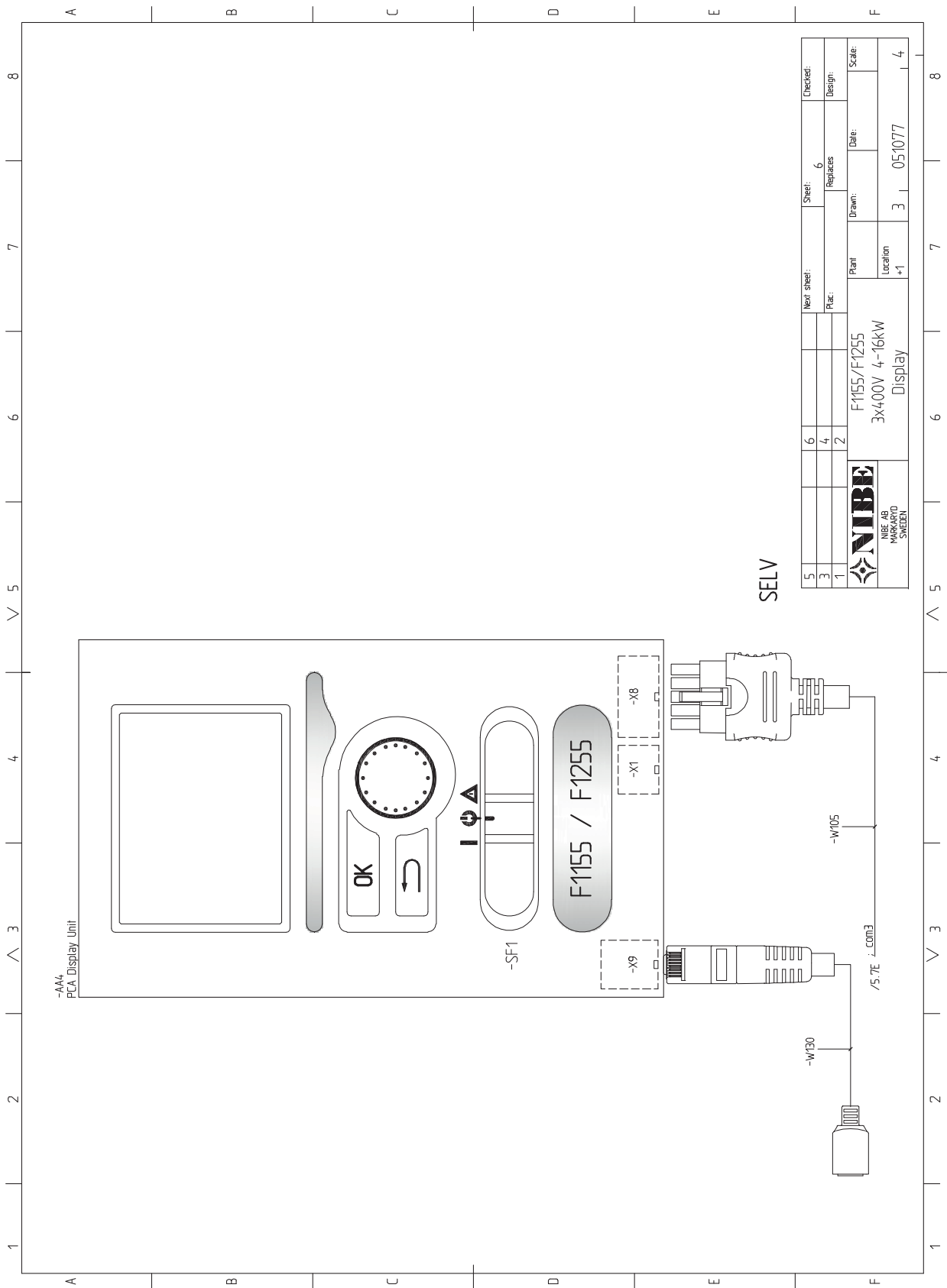

-AA4
PCA Display Unit

SELV

5				Next sheet:	Sheet:	Checked:
3	6			Plac.:	6	Design:
1	4				Replaces	
	2				Drawn:	Date:
				Plant		Scale:
				Location		
				+1		051077
						4



F1155/F1255
3x400V 4-16kW
Display

Dimensions and setting-out coordinates

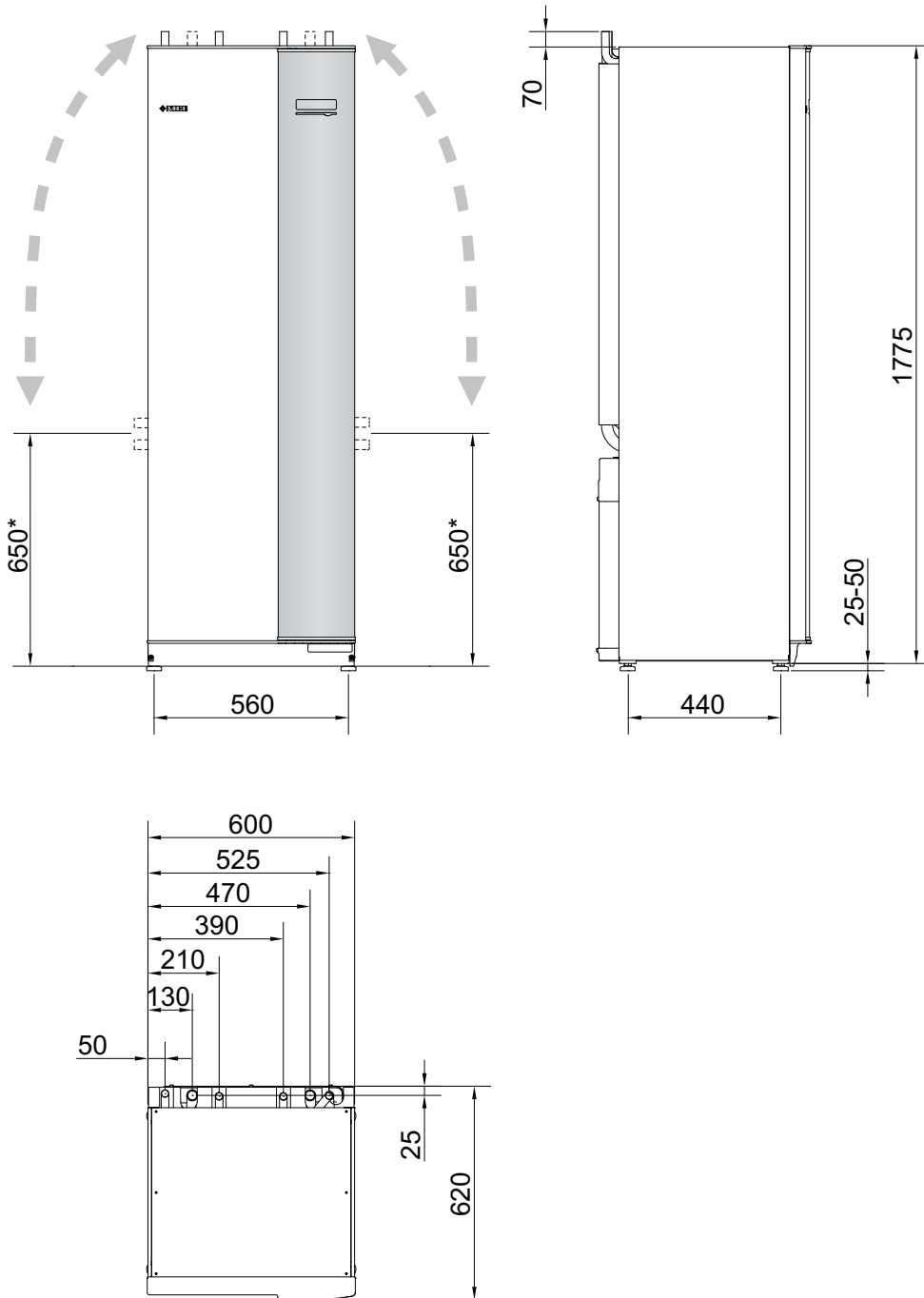

* This dimension applies at 90° angle on the brine pipes (side connection). The dimension can vary approx. ± 100 mm in height as the brine pipes partially consist of flexible pipes.

Technical specifications



1x230V

F1255-6		
Electrical data		
Rated voltage		230V ~ 50Hz
Max operating current including 0 – 0.5 kW immersion heater (Recommended fuse rating).	A_{rms}	15(16)
Max operating current including 1 – 1.5 kW immersion heater (Recommended fuse rating).	A_{rms}	20(20)
Max operating current including 2 – 2.5 kW immersion heater (Recommended fuse rating).	A_{rms}	24(25)
Max operating current including 3 – 4 kW immersion heater (Recommended fuse rating).	A_{rms}	31(32)
Max operating current including 4.5 kW immersion heater (Recommended fuse rating).	A_{rms}	33(40)
Additional power	kW	0.5/1/1.5/2/2.5/3 /3.5/4/4.5

3x230V

F1255-6		
Electrical data		
Rated voltage		230V 3 ~ 50Hz
Max operating current including 0 – 1 kW immersion heater (Recommended fuse rating).	A_{rms}	16(16)
Max operating current including 1.5 – 4.5 kW immersion heater (Recommended fuse rating).	A_{rms}	20(20)
Additional power	kW	0.5/1/1.5/2/2.5/3 /3.5/4/4.5

3x400V

F1255-6		
Electrical data		
Rated voltage		400V 3N ~ 50Hz
Max operating current including 0 kW immersion heater (Recommended fuse rating).	A_{rms}	12(16)
Additional power	kW	0.5/1/1.5/2/2.5/3 /3.5/4/4.5/5/5.5/6/6.5

F1255-16		
Electrical data		
Rated voltage		400V 3N ~ 50Hz
Max operating current including 0 kW immersion heater (Recommended fuse rating).	A_{rms}	10(10)
Max operating current including 1 kW immersion heater (Recommended fuse rating).	A_{rms}	13(16)
Max operating current including 2 – 4 kW immersion heater (Recommended fuse rating).	A_{rms}	17(20)

F1255-16		
Max operating current including 5 – 7 kW immersion heater (Recommended fuse rating).	A_{rms}	21(25)
Max operating current including 9 kW immersion heater, requires reconnection (Recommended fuse rating).	A_{rms}	24(25)
Additional power	kW	1/2/3/4/5/6/7 (switchable to 2/4/6/9)
Short circuit power (S_{sc}) ¹	MVA	2.0

¹ This equipment meets IEC 61000-3-12 on the condition that short circuit power S_{sc} is greater than or equal to 2.0 MVA at the connection point between the customer installation electrical supply and the mains network. It is the responsibility of the installer or user to ensure, through consultation with the distribution network operator if required, that the equipment is only connected to a supply with a short circuit power S_{sc} equal to or greater than 2.0 MVA.

1x230V, 3x230V and 3x400V

		F1255- 6		F1255-16	
Output data at nom flow(50 Hz) <small>Refers to performance of heat pump excl. circulation pumps</small>					
0/35					
Rated output	kW	3.27		9.27	
Electrical output	kW	0.66		1.81	
COP		4.97		5.12	
0/50					
Rated output	kW	2.92		8.95	
Electrical output	kW	0.85		2.50	
COP		3.43		3.59	
Output data according to EN 14511:2011 nominal (50 Hz)					
0/35					
Rated output	kW	3.15		8.89	
Electrical output	kW	0.67		1.83	
COP		4.72		4.85	
0/45					
Rated output	kW	2.87		8.63	
Electrical output	kW	0.79		2.29	
COP		3.61		3.77	
10/35					
Rated output	kW	4.30		11.22	
Electrical output	kW	0.66		1.84	
COP		6.49		6.11	
10/45					
Rated output	kW	3.98		10.92	
Electrical output	kW	0.83		2.32	
COP		4.79		4.72	
SCOP according to EN 14825 Cold climate					
SCOP 0/35, Pdesign		5.5	4 kW	5.5	12 kW
SCOP 0/55, Pdesign		3.9	4 kW	4.1	12 kW
SCOP 0/35, Pdesign		5.4	6 kW	5.4	16 kW
SCOP 0/55, Pdesign		4.0	6 kW	4.1	16 kW
Noise output (L_{WA}) according to EN 12102 at 0/35	dB(A)	36 – 43		36 – 47	
Sound pressure level (L_{PA}) calculated values according to EN ISO 11203 at 0/35 and a distance of 1 m	dB(A)	21 – 28		21 – 32	
Electrical data					
Output, Brine pump	W	10 – 87		20 – 180	
Output, Heating medium pump	W	2 – 63		10 – 87	
IP class		IP 21			
Refrigerant circuit					
Type of refrigerant		R407C			
Volume	kg	1.16		2.2	
Cut-out value pressostat HP	MPa	3.2 (32 bar)			
Difference pressostat HP	MPa	-0.7 (-7 bar)			
Cut-out value pressostat LP	MPa	0.15 (1.5 bar)			
Difference pressostat LP	MPa	0.15 (1.5 bar)			

		F1255-6			F1255-16		
Brine circuit							
Energy class Brine pump		low energy					
Max system pressure brine	MPa	0.45 (4.5 bar)					
Min system pressure brine	MPa	0.05 (0.5 bar)					
Nominal flow (50 Hz)	l/s	0.18			0.51		
Max external avail. press at nom flow	kPa	64			95		
Max/Min incoming Brine temp	°C	see diagram					
Min. outgoing brine temp.	°C	-12					
Heating medium circuit							
Energy class circ-pump		low energy					
Max system pressure heating medium	MPa	0.45 (4.5 bar)					
Min system pressure heating medium	MPa	0.05 (0.5 bar)					
Nominal flow (50 Hz)	l/s	0.08			0.22		
Max external avail. press at nom flow	kPa	69			71		
Max/Min heating medium temp	°C	see diagram					
Pipe connections							
Brine ext diam. CU pipe	mm	28					
Heating medium ext diam. CU pipes	mm	22			28		
Hot water connection external diam	mm	22					
Cold water connection external diam	mm	22					
Water heater							
Volume water heater	l	ca 180					
Max pressure in water heater	MPa	1.0 (10 bar)					
Capacity hot water heating (comfort mode Normal) According to EN16147							
Amount of hot water (40 °C)		245			240		
COP _{DHW} (load profile XL)		2.7			2.7		
Dimensions and weight							
Width	mm	600					
Depth	mm	620					
Height	mm	1800					
Required ceiling height ²⁾	mm	1950					
Corrosion protection		Cu	Rf	E	Cu	Rf	E
Weight complete heat pump	kg	220	200	235	255	235	270
Weight only cooling module	kg	90			125		
Part number, 1x230V		065 273					
Part no., 3x230V, with energy meter		065 316					
Part number, 3x400V		065 267	065 269	065 268	065 059	065 257	065 239
Part no., 3x400V, with energy meter			065 319	065 270		065 314	065 258

²⁾With the feet removed the height is approx 1930 mm for F1255-6 and F1255-16.

Working range heat pump, compressor operation

The compressor provides a supply temperature up to 65 °C, at 0 °C incoming brine temperature, the remainder (up to 70 °C) is obtained using the additional heat.

F1255-6 and F1255-16

This diagram shows the working range below 75 % for F1255-6 and the entire working range for F1255-16.

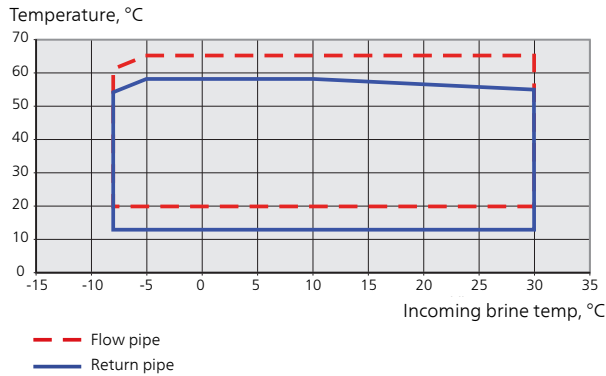

F1255-6

This diagram shows the working range above 75 % for F1255-6

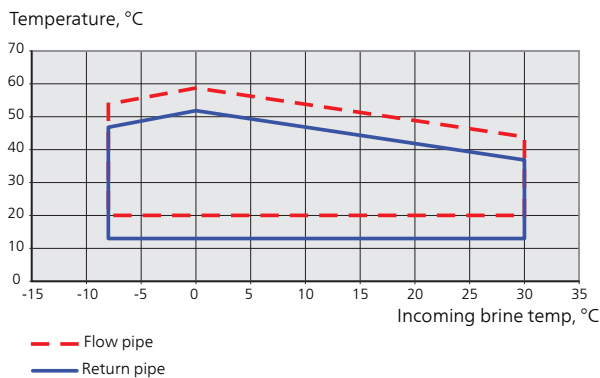

Diagram, dimensioning compressor speed

Heating mode

Use this diagram to dimension the heat pump.

The percentages show approximate compressor speed.

F1255-6

Specified heating output, kW

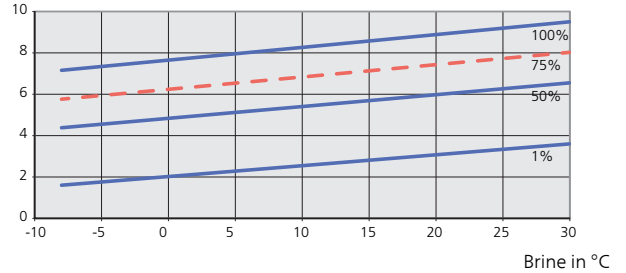

F1255-16

Specified heating output kW

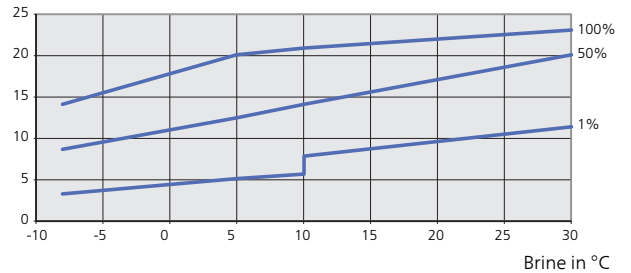

Caution

At operation of F1255-6 above 75% compressor speed, unlocking in menu 5.1.24 is required. This can produce a louder noise level than the value stated in technical data.

Cooling mode



Caution

To dimension heating dump, see the diagram for heating operation.

Supply temperature, heating medium 35 °C

F1255-6

Specified cooling output, kW

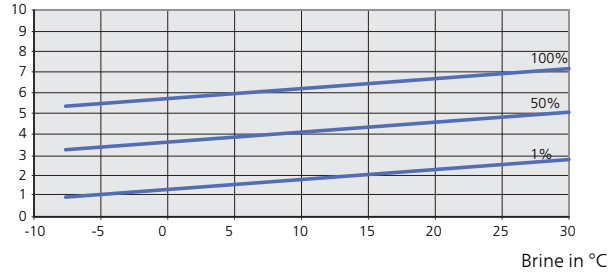

F1255-16

Specified cooling output, kW

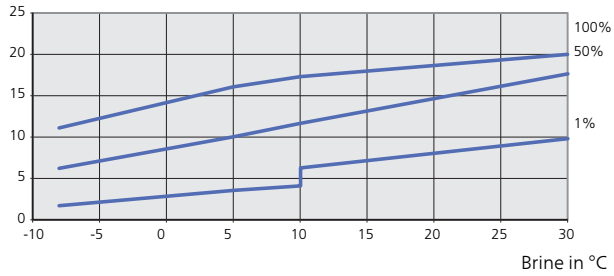

Supply temperature, heating medium 50 °C

F1255-6

Specified cooling output, kW

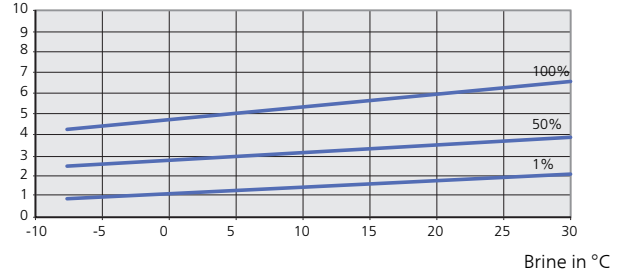

F1255-16

Specified cooling output, kW

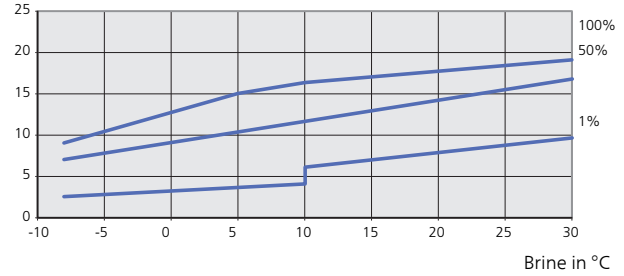

9 Item register

Item register

A

Accessibility, electrical connection, 56
Accessory card (AA5), 25

B

Base card (AA2), 23
Basic
 Accessibility, electrical connection, 56
 Front hatch, 54
 Removing the covers, 54
 Top panel, 54

C

Component description
 Sensors
 Temperature sensor data, 21
Component replacement
 Basic
 Accessibility, electrical connection, 56
 Front hatch, 54
 Removing the covers, 54
 Top panel, 54
 Circuit boards and electronics
 Inverter (???), 72
 Inverter (???), 72
Compressor heater, 16
Compressor protection, 15
 Compressor heater, 16
 High pressure switch, 15
 Low pressure pressostat, 15
 Oil temp., 16
 Time conditions, 16
 Working area, 15
Contact information, 4
Cooling circuit, 15
 Compressor protection
 Compressor heater, 16
 High pressure switch, 15
 Low pressure pressostat, 15
 Time conditions, 16
 Working area, 15
 Outline diagram, 15
Cooling section, 8

D

Description of functions
 Compressor protection, 15
 Oil temp., 16
 Cooling circuit, 15
 Outline diagram, 15
 Electronics, 22
 Accessory card (AA5), 25
 Base card (AA2), 23
 Extra relay circuit board (AA7), 24
 Immersion heater card (AA1), 22, 51
 MODBUS 40, 24
 SMS 40, 24
Diagram, dimensioning compressor speed, 104
Dimensions and setting-out coordinates, 99
Drawing out the cooling module, 54

E

Electrical cabinets, 7
Electrical connections
 Accessibility, electrical connection, 56
 Removing the cover, base board, 56
 Removing the cover, immersion heater circuit board, 56
 Removing the hatch, input circuit board, 56

Electronics, 22

 Accessory card (AA5), 25
 Base card (AA2), 23
 Extra relay circuit board (AA7), 24
 Immersion heater card (AA1), 22, 51
 MODBUS 40, 24
 SMS 40, 24

Extra relay circuit board (AA7), 24

F

Front hatch, 54
Function check, circulation pumps, 53
Function check, relays/components
 Function check, circulation pumps, 53

H

High pressure switch, 15

I

Immersion heater card (AA1), 22, 51
Important information
 Safety information, 3
Inverter (???), 72

L

Low pressure pressostat, 15

M

Marking, 3
MODBUS 40, 24

O

Oil temp., 16
Outline diagram, 15

R

Removing the cover, base board, 56
Removing the cover, immersion heater circuit board, 56
Removing the covers, 54
Removing the hatch, input circuit board, 56

S

Safety information, 3
 Marking, 3
 Symbols, 3

Sensors

 Temperature sensor data, 21

Serial number, 3

Service actions

 Drawing out the cooling module, 54

SMS 40, 24

Symbols, 3

T

Technical data

 Dimensions and setting-out coordinates, 99

 Technical Data, 100

Technical Data, 100

 Diagram, dimensioning compressor speed, 104

 Working range heat pump, 104

Temperature sensor data, 21

The heat pump design, 5

 Component list cooling section, 8

 Component list electrical cabinets, 7

 Component location cooling section, 8

 Component location electrical cabinets, 7

 Component locations, 5

 List of components, 5

Time conditions, 16

Top panel, 54

Troubleshooting
 Function check, relays/components
 Function check, circulation pumps, 53

W

Working area, 15
Working range heat pump, 104

NIBE AB Sweden
Hannabadsvägen 5
Box 14
SE-285 21 Markaryd
info@nibe.se
www.nibe.eu