

Hot water heat pump NIBE F110

The NIBE F110 is a water heater with built-in heat pump for energy-efficient hot water production.

The NIBE F110 provides great savings for houses that use direct electricity and recovers energy from the outdoor air or through heat recovery of ventilation air.

The NIBE F110 has a display with easy-to-read menus which facilitate the setting of pleasant hot water comfort. Hot water and ventilation can be scheduled for every day of the week or for longer periods.

- Energy-efficient hot water production with heat pump technology.
- Great savings with energy recovery for houses that use direct electricity.
- Recovers energy from ventilation air or outdoor air.



This is how F110 works

Principle

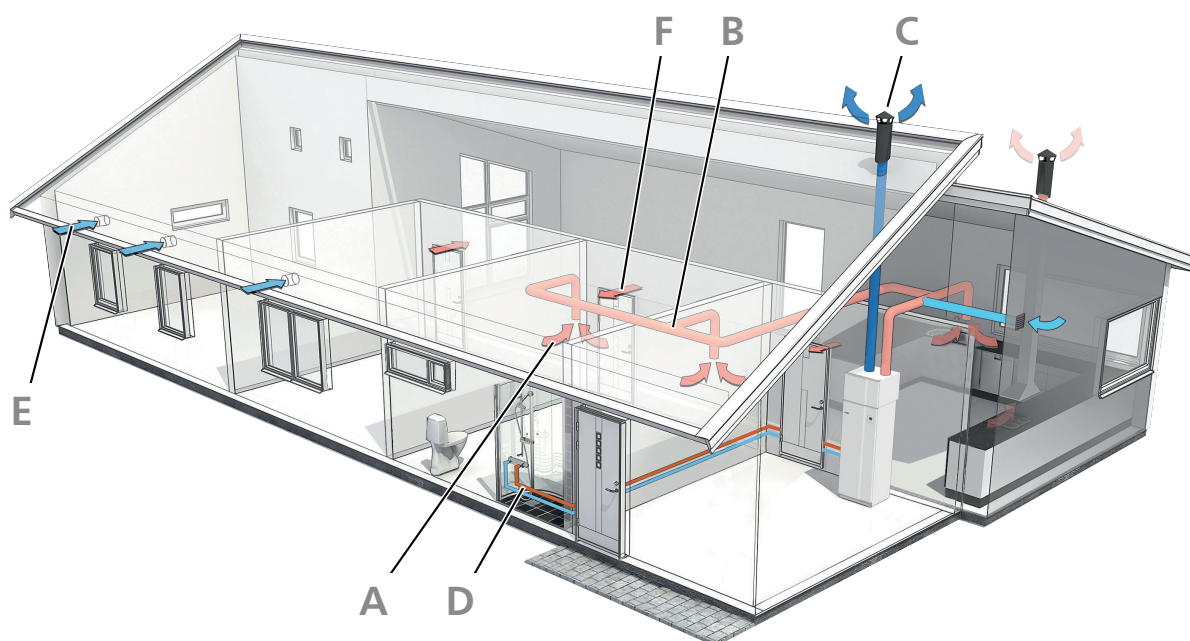

F110 is a heat pump with an integrated DC fan and a water heater that has copper or stainless steel corrosion protection. In addition, it has an integrated immersion heater.

Energy is recovered from the ventilation air and supplied to the heat pump, which reduces energy costs considerably. The device ventilates the house and produces domestic hot water.

F110 is intended for both new installations and replacement in houses or similar.

- A** The warm room air is drawn into the air duct system.
- B** The warm room air is fed to F110.
- C** The room air is released when it has passed F110. The air temperature has then been reduced as F110 has extracted the energy in the room air.
- D** F110 supplies the house with hot water.
- E** Outdoor air is drawn into the house.
- F** Air is transported from rooms with outdoor air devices to rooms with exhaust air valves.

Design

Control of F110 is designed to ensure easy operation while always enabling the heat pump to run as efficiently as possible. F110 decides on the best operation mode. The display shows the current temperatures and set values in plain text.

The design of the ventilation section provides a high ventilation capacity. In addition, the continuously adjustable fan can easily be increased or reduced via the display unit.

F110 gives great savings thanks to an efficient compressor, which, by means of intelligent control, works with the most favourable temperature conditions at the time.

The insulation consists of moulded Neopor (environmentally friendly cellular plastic) for minimal heat loss.

The outer casing is of white powder-coated steel plate. The front door is easy to remove for easy access when installing and for servicing.

Principle of operation, cooling circuit

When the air passes through the evaporator, the refrigerant evaporates because of its low boiling point. In this way the energy in the air is transferred to the refrigerant.

The refrigerant is then compressed in a compressor, causing the temperature to rise considerably.

The warm refrigerant is led to the condenser. Here, the refrigerant gives off its energy to the hot water, whereupon the refrigerant changes state from gas to liquid.

The refrigerant then goes via filters to the expansion valve, where the pressure and temperature are reduced.

The refrigerant has now completed its circulation and returns to the evaporator.

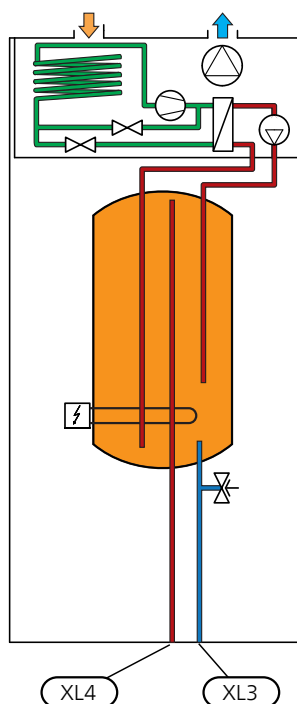

XL3	Cold water connection
XL4	Hot water connection

This is a principle of operation, differences may occur in the installation in question.

Good to know about F110

Transport and storage Supplied components

F110 should be transported and stored vertically in a dry place. However, the F110 may be carefully laid on its back when being moved into a building. The centre of gravity is in the upper part.



Silencer

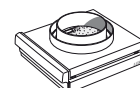

Filter cartridge

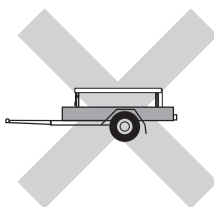
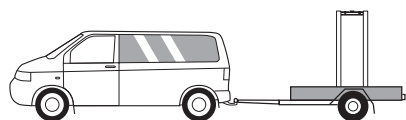

LOCATION

The kit of supplied items is placed in the lower section of the product.

Installation and positioning

- Position F110 on a fixed foundation that can take the weight of the heat pump.

Because water comes from F110, the floor coating is important. A waterproof floor or floor membrane is recommended.

- Because water comes from F110, it is good if the area where the heating pump is located is provided with floor drainage.
- Install with its back to an outside wall, ideally in a room where noise does not matter, in order to eliminate noise problems. If this is not possible, avoid placing it against a wall behind a bedroom or other room where noise may be a problem.
- Wherever the unit is located, walls to sound sensitive rooms should be fitted with sound insulation.
- Route pipes so they are not fixed to an internal wall that backs on to a bedroom or living room.
- The heat pump's installation area should always have a temperature of at least 10 °C and max 30 °C.

Regularly check that the overflow cup and any floor drains are not blocked; water must be able to run through freely. Clean, if necessary.

SOUND POWER LEVEL

Sound effect level according to EN 12102

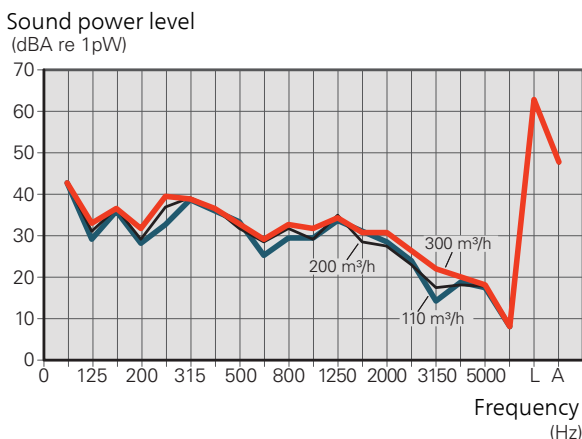

For more detailed sound data, including sound to channels, visit nibe.se.

INSTALLATION AREA

Leave a free space of 800 mm in front of the product. Leave free space between F110 and wall/other machinery/fittings/cables/pipes etc. It is recommended that a space of at least 10 mm is left to reduce the risk of noise and of any vibrations being propagated.

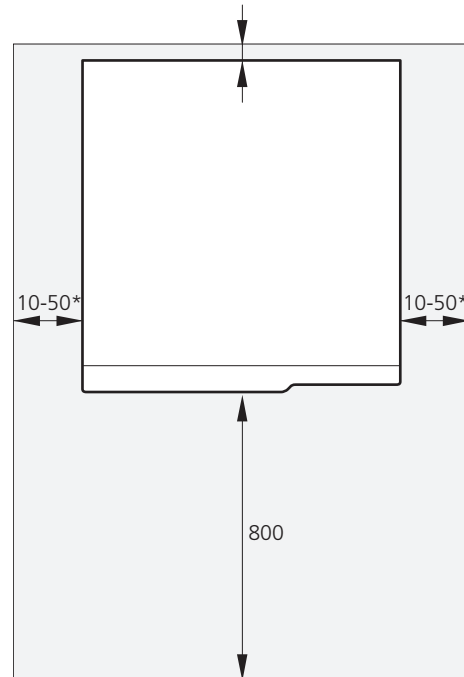

* Depending on whether the panels can be removed or not.

Ensure that there is sufficient space (300 mm) above F110 for installing ventilation hoses.

Installation

Equipment

F110 is supplied with a complete set of valves, comprising a shut-off valve, mixing valve, vacuum valve, vent valve and safety valve.

Pipe installation

CONNECTING COLD AND HOT WATER

The valve connector must not be used for external installation, relocation or separation.



For more information see nibe.se.

Installation alternative

INSTALLATION ALTERNATIVE

Exhaust air

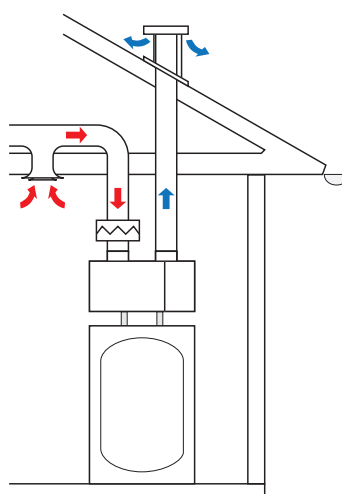

Connecting the exhaust air

With an exhaust air connection the heat in the building's ventilation air is used to heat the hot water while the house is ventilated.

The hot air is transferred from the rooms to the heat pump via the house ventilation system.

Outdoor air

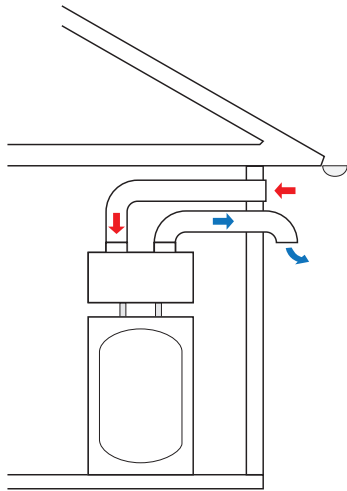

Connecting the outdoor air

With outdoor air connection the heat in the outdoor air is used to heat up the hot water.

- The pressure drop in the system must not exceed 60 Pa. Factors affecting the pressure drop include the dimensions of the air ducts, the number of bends and the length of the ducts. Example: In a system with 160 mm air ducts and 7 bends, the ducts may be a maximum of 8 m in length.
- Attempt to find a location for F110 on the side of the house that faces the least sound sensitive neighbouring area.

Surrounding air

Take incoming air from one room and release the outgoing air to the same room.

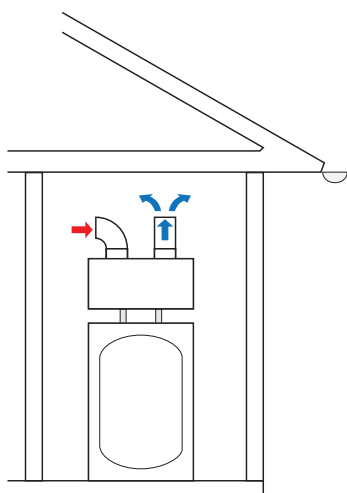

Connecting surrounding air

With surrounding air connection the heat in the room air is used to heat up the hot water. The outgoing air can be used to cool a room.

In installations where air is taken from one room and released into another, there can be over pressure if the room is not ventilated correctly. This can lead to damp in the building.

Ventilation

- Connect F110 so that all the exhaust air, except kitchen duct air (kitchen fan), passes through the evaporator in the heat pump.
 - The ventilation flow must comply with the applicable national standards.
 - For optimum heat pump performance, the ventilation flow must not be less than 20 l/s (72 m³/h) at normal exhaust air temperature. At lower exhaust air temperatures, a higher flow is required.
 - If the exhaust air temperature falls below 10°C or the outdoor air is below -10°C, the compressor is blocked and electric additional heat is permitted. Energy is not recovered from the exhaust air/outdoor air when the compressor is blocked.
 - Connections must be made via flexible hoses, which should be installed so that they are easy to replace.
 - The air duct system must be a minimum of air tightness class B.
 - To prevent fan noise being transferred to the ventilation devices, silencers should be installed in the duct system. In the event of ventilation devices in noise-sensitive rooms, silencers must be installed.
- For installation with ambient air, the enclosed silencer has to be fitted in F110.
- Ducts that may become cold must be insulated with diffusion-proof material (at least PE30 or equivalent) along their entire length.
 - Exhaust air ducts that are routed in cold areas must be insulated.
 - All joins in the ducting must be sealed to prevent leakage.
 - For installation with outdoor air, the air must be routed to the outdoor air duct through an outer wall grille in the facade. The outer wall grille must be installed so

that it is protected from the weather and must be designed so that no rainwater and/or snow can penetrate the facade or follow the air into the duct.

- When positioning the outdoor air and extract air hood/grille for outdoor air installation, bear in mind that the two air flows must not short circuit, thus preventing the extract air from being drawn into F110 again.
- When positioning the exhaust air and extract air ducts for installation with ambient air, bear in mind that the two air flows must not short circuit, thus preventing the extract air from being drawn into F110 again.
- The heat pump must be provided with the enclosed air filter.
- A duct in a masonry chimney stack must not be used for extract air.
- If a stove or similar is installed, it must have airtight doors. It must also be able to take combustion air from outside.
- Incorrect adjustment of the ventilation may lead to reduced installation efficiency and thus poorer operating economy, and may cause moisture damage in the building

Electrical connections

F110 is connected to an earthed socket with the factory-installed connection cable (length approx. 2.8 m), which is fitted with a plug.

For permanent installations, the hot water heat pump must be connected with an isolator switch with a minimum breaking gap of 3 mm.

Other electrical equipment is connected at the factory.

SETTING THE FAN CAPACITY

Select the ventilation capacity steplessly in the display.

Fan capacity

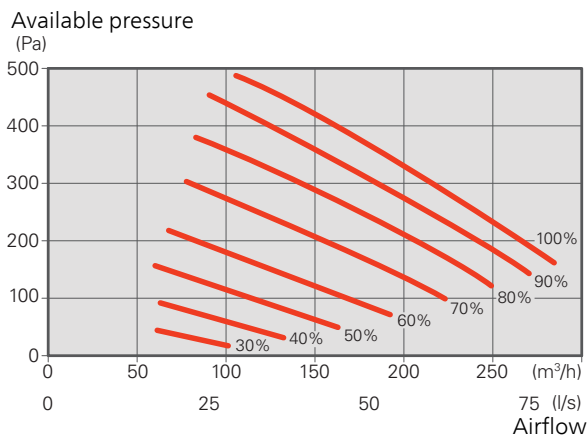

VENTILATION CONNECTIONS

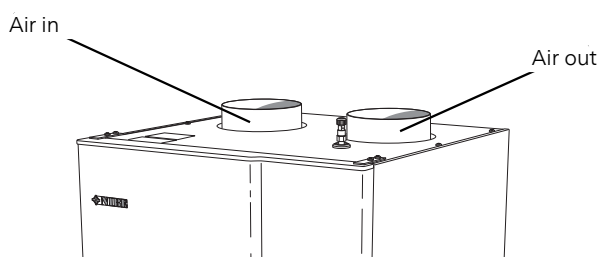

Functions

Hot water production



Hot water charging starts when the temperature has fallen to the set start temperature. Hot water charging stops when the hot water temperature at the hot water sensor has been reached.

For occasional higher hot water demand, there is a function called "temporary lux" that allows the temperature to be raised via one time increase or up to 12 hours (selected in the menu system).

It is also possible to set F110 in holiday mode, which means that the lowest possible temperature is achieved without the risk of freezing.

Additional heat only

F110 can be used with additional heat only (electric boiler) to produce hot water, for example before the ventilation system is complete.

Alarm indications

Depending on the fault, information is shown in the display. An alarm log is created with each alarm, which shows the most recent 10 alarms and information about the heat pump at the time each alarm occurred.

F110 is controlled using a clear and easy to use display.

Instructions, settings and operational information are shown on the display. You can easily navigate between the different menus and options to set the comfort or obtain the information you require.

Accessories

Detailed information about the accessories and complete accessories list available at nibe.se.

Not all accessories are available on all markets.

Base extension EF 45

This accessory is used to create a larger connection area under F110.

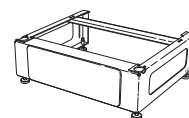

Separable valve connector

For external installation, relocation or separation.

Top cabinet

Top cabinet that conceals the ventilation ducts.

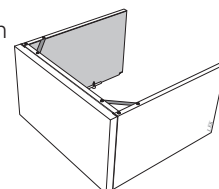

Technical data

Dimensions

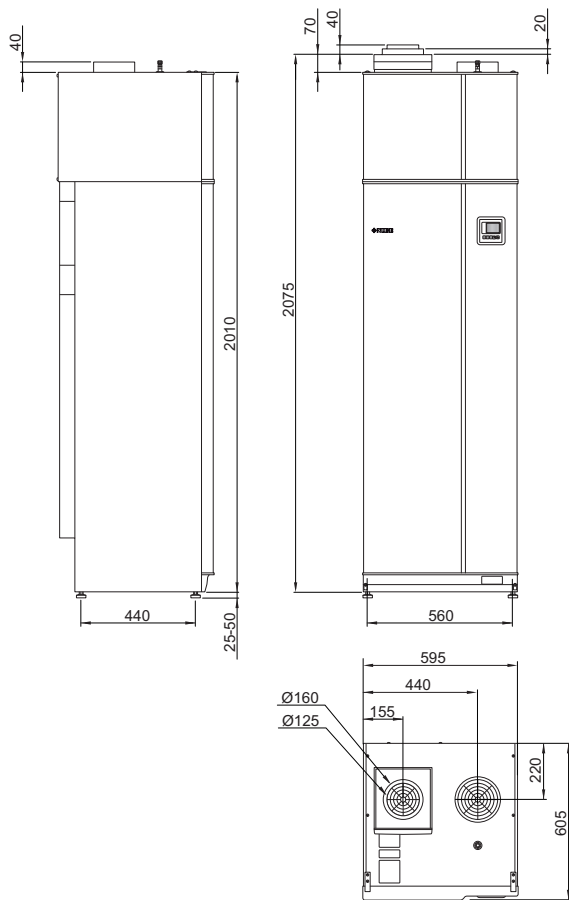

Pipe connections

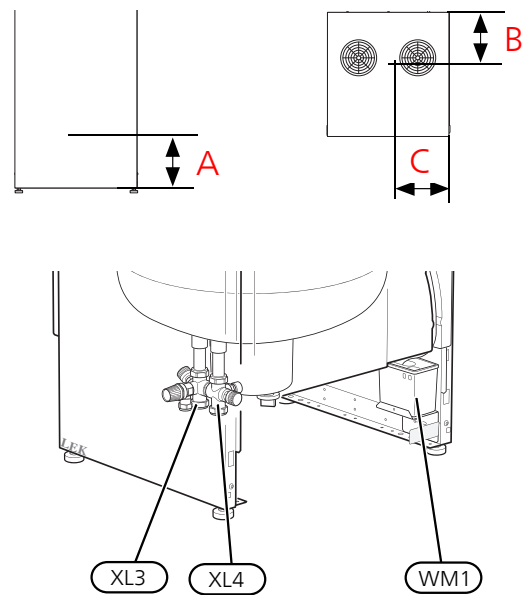

SETTING OUT DIMENSIONS

Connection		A	B	C
XL3 Cold water	(mm)	125	295	435
XL4 Hot water	(mm)	125	350	435
WM1 Overflow cup	(mm)	140	450	68

PIPE DIMENSIONS

Connection		
XL3 Cold water ext \varnothing	(mm)	22
XL4 Hot water ext \varnothing	(mm)	22
WM2 Overflow water discharge	(mm)	32

Technical data ϵ

Type		Exhaust air	Outdoor air	Surrounding air
<i>Output data according to EN 16 147</i>				
Capacity (P _H)/COP	kW/-	1.32 / 2.89 ¹	1.08 / 2.36 ²	1.32 / 3.27 ³
<i>Additional power</i>				
Output immersion heater	kW	1.3		
<i>Energy rating, average climate</i>				
The product's hot water heating efficiency class ⁴		A	A	A+
Declared load profile		XL		
<i>Electrical data</i>				
Rated voltage	V	230 V ~ 50 Hz		
Max operating current	A	9.1		
Min. fuse rating	A	10		
Enclosure class		IP21		
<i>Refrigerant circuit</i>				
Type of refrigerant		R134A		
GWP refrigerant		1430		
Volume	kg	0.38		
CO ₂ equivalent	ton	0.54		
<i>Air flow requirement</i>				
Min. air flow at exhaust air temperature below 10°C	l/s	-	83	-
Min. air flow at exhaust air temperature at least 10°C	l/s	25	42	25
Temperature range for compressor operation	°C	10 - 37	-10 - 37	10 - 37
<i>Noise</i>				
Sound effect level according to EN 12 102 (L _{W(A)}) ⁵	dB(A)	47.0		
Sound pressure level in the installation area according to EN ISO 11 203 (L _{P(A)}) ⁶	dB(A)	43.0		

1 A20(12), luftflöde 50 l/s (180 m³/h)

2 A7(6), luftflöde 70 l/s (250 m³/h)

3 A20(12), luftflöde 50 l/s (180 m³/h)

4 Scale for efficiency class hot water: A+ to F.

5 The value varies with the fan speed selected. For more detailed sound data, including sound to ducts, visit nibe.se.

6 The value can vary with the room's damping capacity. These values apply at a damping of 4 dB.

Other 1x230 V		Copper	Stainless
<i>Water heater</i>			
Volume, hot water heater	litre	265	
Max pressure in hot water heater	MPa/bar	1.0 / 10.0	
Safety valve deploys at	MPa/bar	0.9 / 9.0	1.0 / 10.0
Max temperature with compressor	°C	56	
Max temperature with additional heat	°C	95	
<i>Capacity hot water heating</i>			
Tap volume 40°C according to EN 16 147(V _{max}) ¹	litre	365	
<i>Miscellaneous</i>			
Required ceiling height	mm	2,110	
Weight	kg	144	127

1 A20(12), air flow 50 l/s (180 m³/h). Comfort mode, normal.

NIBE Energy Systems
Box 14, SE-285 21 Markaryd
nibe.se

PBD EN 1850-2 M12279

This product sheet is a publication from NIBE Energy Systems. All product illustrations, facts and data are based on current information at the time of the publication's approval. NIBE Energy Systems makes reservations for any factual or printing errors in this product sheet.

©2018 NIBE ENERGY SYSTEMS