

Installer manual



Air/water heat pump

NIBE S2125 UK 1x230V



IHB EN 2212-1
631680

Table of Contents

1	Important information	4			
	Safety information	4		Master control	33
	Symbols	4		Control conditions	34
	Marking	4		Control - Heat pump EB101	35
	Serial number	4	8	Service	38
	Country specific information	5		Service actions	38
	Inspection of the installation	6	9	Servicing and maintenance	39
	Compatible indoor modules (VVM) and control modules (SMO)	7		Important	39
	Indoor module	7		General inspection	39
	Control module	7		Heating System	39
2	Delivery and handling	8	10	Disturbances in comfort	40
	Transport	8		Troubleshooting	40
	Assembly	9		Alarm list	42
	Condensation	11	11	Accessories	44
	Supplied components	12	12	Technical data	45
	Removing the side panel and top panel	13		Dimensions	45
	Installation of automatic gas separator	14		Sound levels	46
3	The heat pump design	17		Technical specifications	47
	General	17		Energy labelling	50
	Distribution box	20		Electrical circuit diagram	53
	Sensor placement	21		Item register	57
4	Pipe connections	22		Contact information	63
	General	22			
	Symbol key	23			
	Pipe coupling heating medium circuit	23			
5	Electrical connections	25			
	General	25			
	Accessibility, electrical connection	25			
	Connections	26			
6	Commissioning and adjusting	31			
	Preparations	31			
	Filling and venting	31			
	Start-up and inspection	31			
	Post adjustment and venting	31			
	Adjustment, charge flow	32			
7	Control	33			
	General	33			
	LED status	33			

Important information

Safety information

This manual describes installation and service procedures for implementation by specialists.

The manual must be left with the customer.

Symbols

Explanation of symbols that may be present in this manual.



NOTE

This symbol indicates danger to person or machine.



Caution

This symbol indicates important information about what you should consider when installing or servicing the installation.



TIP

This symbol indicates tips on how to facilitate using the product.

Marking

Explanation of symbols that may be present on the product's label(s).



Fire hazard!



Read the User Manual.



Read the Installer Manual.



Disconnect the voltage supply before starting work.



Dangerous voltage.

Serial number

The serial number can be found on the rear cover and at the bottom on the side.

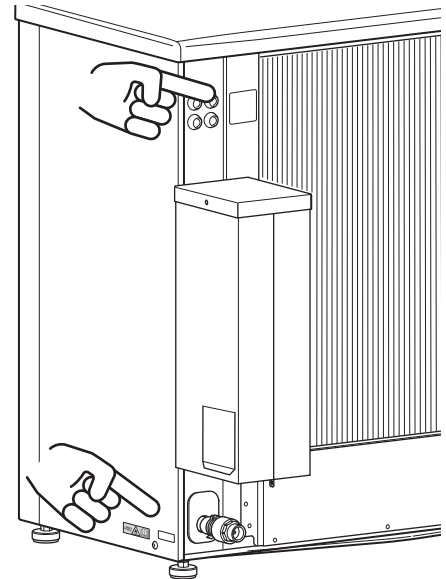

Caution

You need the product's (14 digit) serial number for servicing and support.

Country specific information

UNITED KINGDOM

This installation is subject to building regulation approval, notify the local Authority of intention to install.

Use only manufacturer's recommended replacement parts.

For more information see www.nibe.co.uk.



Benchmark places responsibilities on both manufacturers and installers. The purpose is to ensure that customers are provided with the correct equipment for their needs, that it is installed, commissioned and serviced in accordance with the manufacturers instructions by competent persons and that it meets the requirements of the appropriate Building Regulations. The Benchmark Checklist can be used to demonstrate compliance with Building Regulations and should be provided to the customer for future reference.

Installers are required to carry out the installation, commissioning and servicing work in accordance with the Benchmark Code of practice which is available from the Heating and Hotwater Industry Council who manage and promote the Scheme. Visit centralheating.co.uk for information.

Warranty and insurance information

Thank you for installing a new NIBE heat pump in your home.

NIBE heat pumps are manufactured in Sweden to the very highest standard so we are pleased to offer our customers a comprehensive guarantee.

The product is guaranteed for 24 months for parts and labour from the date of installation or 33 months from the date of manufacture, whichever is the shorter.

The NIBE guarantee is based on the unit being installed and commissioned by a NIBE accredited installer, serviced every year and the Benchmark documents completed. Where this condition is not met, any chargeable spare parts or components issued within the applicable guarantee period still benefit from a 12 month warranty from the date of issue by the manufacturer.

We recommend the installer completes and returns as soon as possible, your guarantee registration card or completes the guarantee form on the NIBE website www.nibe.co.uk

Electrical Supply

The heat pump must be permanently connected to a 230 V ~ 50 Hz supply.

All system components shall be of an approved type and all wiring to current I.E.E wiring regulations.

External wiring must be correctly earthed, polarised and in accordance with the relevant standards: Currently this is BS 7671.

Heating System

The installation of the heat pump should follow best practice as covered in the following:

BS 5449 Forced circulation hot water central heating systems for domestic premises.

BS 15450 Heating systems in buildings – Design of heat pump heating systems.

Inspection of the installation

Current regulations require the heating installation to undergo an installation inspection before it is commissioned. The inspection must be carried out by a suitably qualified person. In addition, fill in the page for information regarding the installation data in the User Manual.

✓	Description	Notes	Signature	Date
	Heating medium (page 22)			
	Automatic gas separator installed			
	System flushed			
	System vented			
	Particle filter			
	Shut-off and drain valve			
	Charge flow set			
	Electricity (page 25)			
	Fuses property			
	Safety breaker			
	Earth circuit-breaker			
	Heating cable type/effect			
	Fuse size, heating cable (F3)			
	Communication cable connected			
	S2125 addressed (only when cascade connection)			
	Cooling permitted			
	Connections			
	Main voltage			
	Phase voltage			
	Miscellaneous			
	Condensation water pipe			
	Insulation for condensation water pipe, thickness (unless KVR 11 is used)			
	Warranty			
	Benchmark checklist			



NOTE

Check the connections, main voltage and phase voltage before powering up the heat pump, to prevent damage to the heat pump electronics.

Compatible indoor modules (VVM) and control modules (SMO)

	VVM S320	SMO S40
S2125-8	X	X
S2125-12	X	X

	VVM 225	SMO 20	SMO 40
S2125-8	X	X	X
S2125-12		X	X

Indoor module

VVM S320

Stainless steel, 1x230 V
With T&P valve
Part no. 069 199

VVM 225

Stainless steel, 1x230 V
With T&P valve
Part no. 069 232

Control module

SMO S40

Control module
Part no. 067 654

SMO 20

Control module
Part no. 067 224

SMO 40

Control module
Part no. 067 225

Delivery and handling

Transport

S2125 must be transported and stored vertically.



NOTE

Ensure that the heat pump cannot fall over during transport.

Check that the heat pump has not been damaged during transport.

LIFT FROM THE STREET TO THE SET UP LOCATION

If the base allows, the simplest thing is to use a pallet truck to move the S2125 to the set up location.



NOTE

The centre of gravity is offset to one side (see print on the packaging).

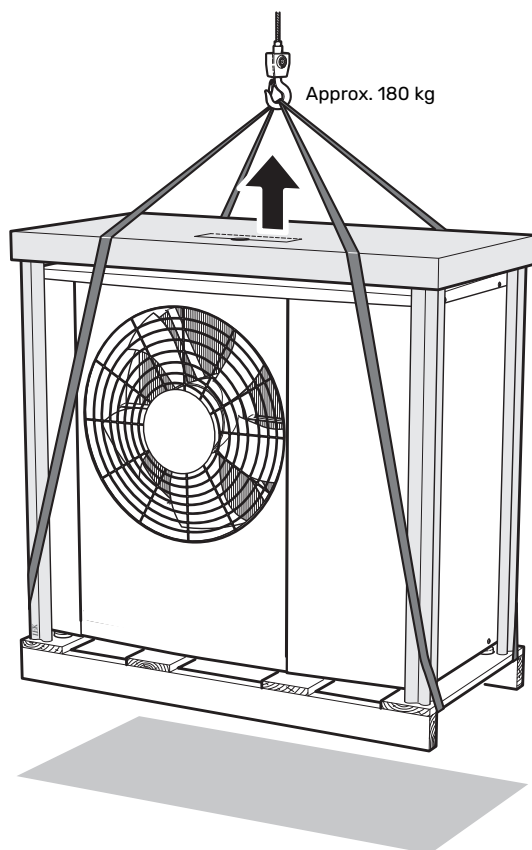

If S2125 needs to be transported across soft ground, such as a lawn, we recommend using a crane truck that can lift it to the installation location. When S2125 is lifted with a crane, the packaging must be untouched.

If a crane vehicle cannot be used the S2125 can be transported on an extended sack truck. S2125 must be taken from its heaviest side and two people are required to lift S2125.

LIFT FROM THE PALLET TO FINAL POSITIONING

Before lifting remove the packaging and the securing strap to the pallet.

Place lifting straps around each machine foot. Lifting from the pallet to the base requires four persons, one for each lifting strap.

SCRAPPING

When scrapping, the product is removed in reverse order. Lift by the bottom panel instead of a pallet!

Assembly

- Place the heat pump in a suitable location outdoors to prevent any risk of the refrigerant flowing in through ventilation openings, doors or similar openings in the event of a leak. It must also not constitute a hazard to people or property in any other way.
- If the heat pump is placed in a location where any refrigerant leak could accumulate, for example below ground level (in a dip or low-lying recess), the installation must satisfy the same requirements that apply for gas detection and the ventilation of engineering rooms. Requirements regarding sources of ignition must be applied where appropriate.
- Place S2125 outdoors on a solid level base that can take the weight, preferably a concrete foundation. If concrete slabs are used they must rest on asphalt or shingle.
- The lower edge of the evaporator must not be lower than the level of the average local snow depth. The base should be at least 70 mm tall.
- S2125 should not be positioned next to noise sensitive walls, for example, next to a bedroom.
- Also ensure that the placement does not inconvenience the neighbours.
- S2125 must not be placed so that recirculation of the outdoor air is possible. Recirculation entails reduced power and impaired efficiency.
- The evaporator must be sheltered from direct wind / , which negatively affects the defrosting function. Place S2125 protected from wind / against the evaporator.
- A small amount of water may drip from the drainage hole under S2125. Make sure that the water can run away by selecting a suitable material underneath S2125 (see section "Condensation").
- Care must be exercised so that the heat pump is not scratched during installation.

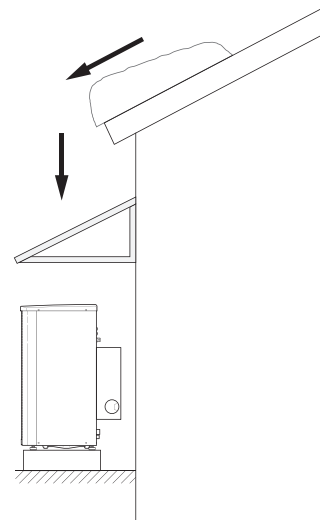

If there is a risk of snow slip from roof, a protective roof or cover must be erected to protect the heat pump, pipes and wiring.

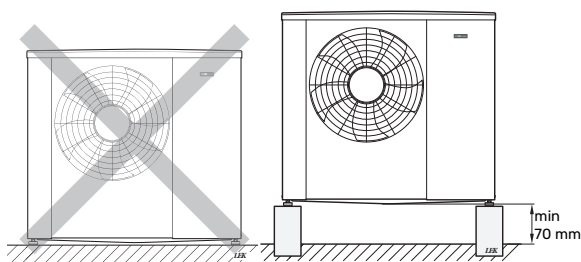

Do not place S2125 directly on the lawn or other non solid surface.

INSTALLATION AREA

The distance between S2125 and the house wall must be at least 350 mm, but not more than 500 mm in locations that are exposed to the wind. The free space above S2125 must be at least 1,000 mm. The free space in front must be at least 1,000 mm for any future servicing.

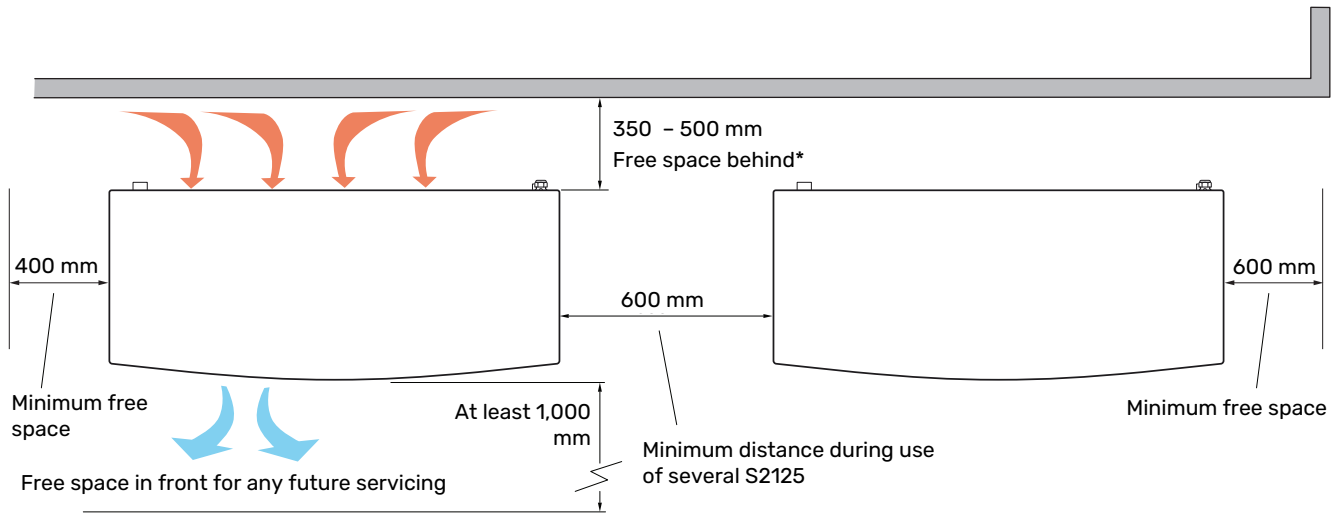

* The space behind must not exceed 500 mm in locations that are exposed to the wind.

Condensation

The condensate drain pan collects and leads away the condensation water.



NOTE

It is important to the heat pump function that condensation water is led away and that the drain for the condensation water run off is not positioned so that it can cause damage to the house.

Condensation run-off should be checked regularly, especially during the autumn. Clean if necessary.

- The condensation water (up to 50 litres/24 hrs) that collects in the trough should be routed away by a pipe to an appropriate drain, it is recommended that the shortest outdoor stretch possible is used.
- The section of the pipe that can be affected by frost must be heated by the heating cable to prevent freezing.



TIP

Pipe with heating cable for draining the condensation water trough is not included.

To ensure the function, the accessory KVR 11 should be used.

- Route the pipe downward from S2125.
- The outlet of the condensation water pipe must be at frost free depth.
- Use a water trap for installations where air circulation may occur in the condensation water pipe.
- The insulation must seal against the bottom of the condensation water trough.

DRAINAGE OF CONDENSATION

Stone caisson

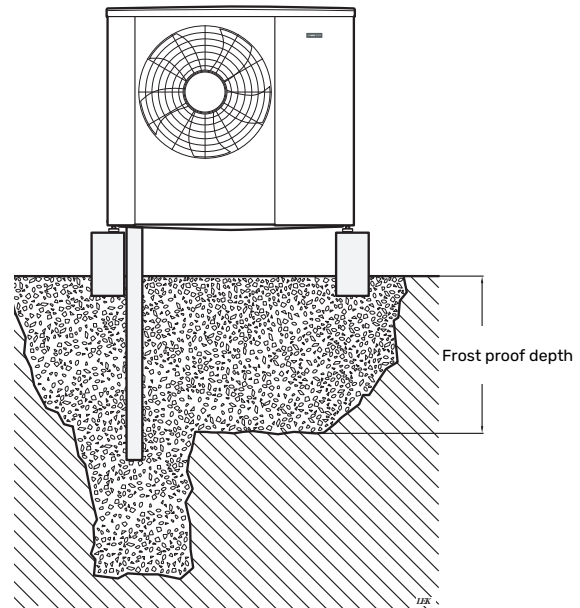

If the house has a cellar the stone caisson must be positioned so that condensation water does not affect the house. Otherwise the stone caisson can be positioned directly under the heat pump.

Gutter drainage

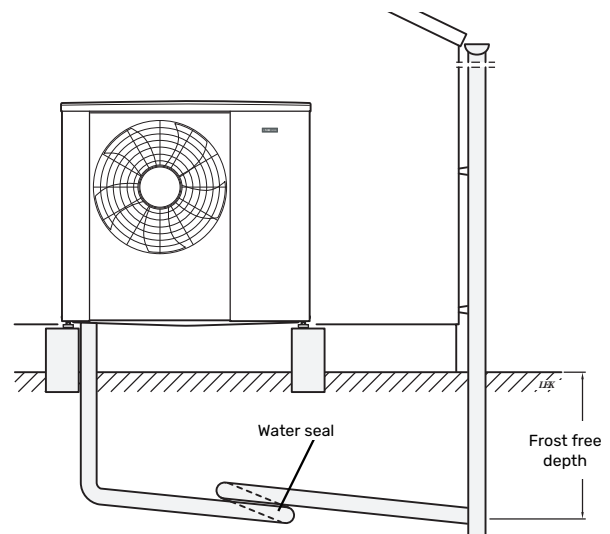

Route the pipe downward from S2125.

The condensation water pipe must have a water seal to prevent air circulation in the pipe.



Caution

If none of the recommended alternatives is used good lead off of condensation water must be assured.

Supplied components

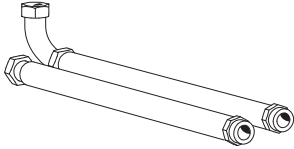

1 x flexible pipe with bend
(WN1)
1 x flexible pipe (WN2)
(Dimensions, flexible pipes
DN25, G1")
4 x gaskets

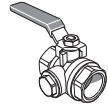

1 x filterball (G1") (QZ2)

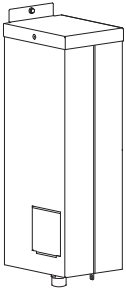

1 x automatic gas separator
(HQ8)

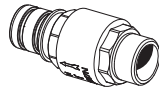

1 x non-return valve (RM1.2)

Removing the side panel and top panel

Undo the screws, lift off the top panel and the top insulation.

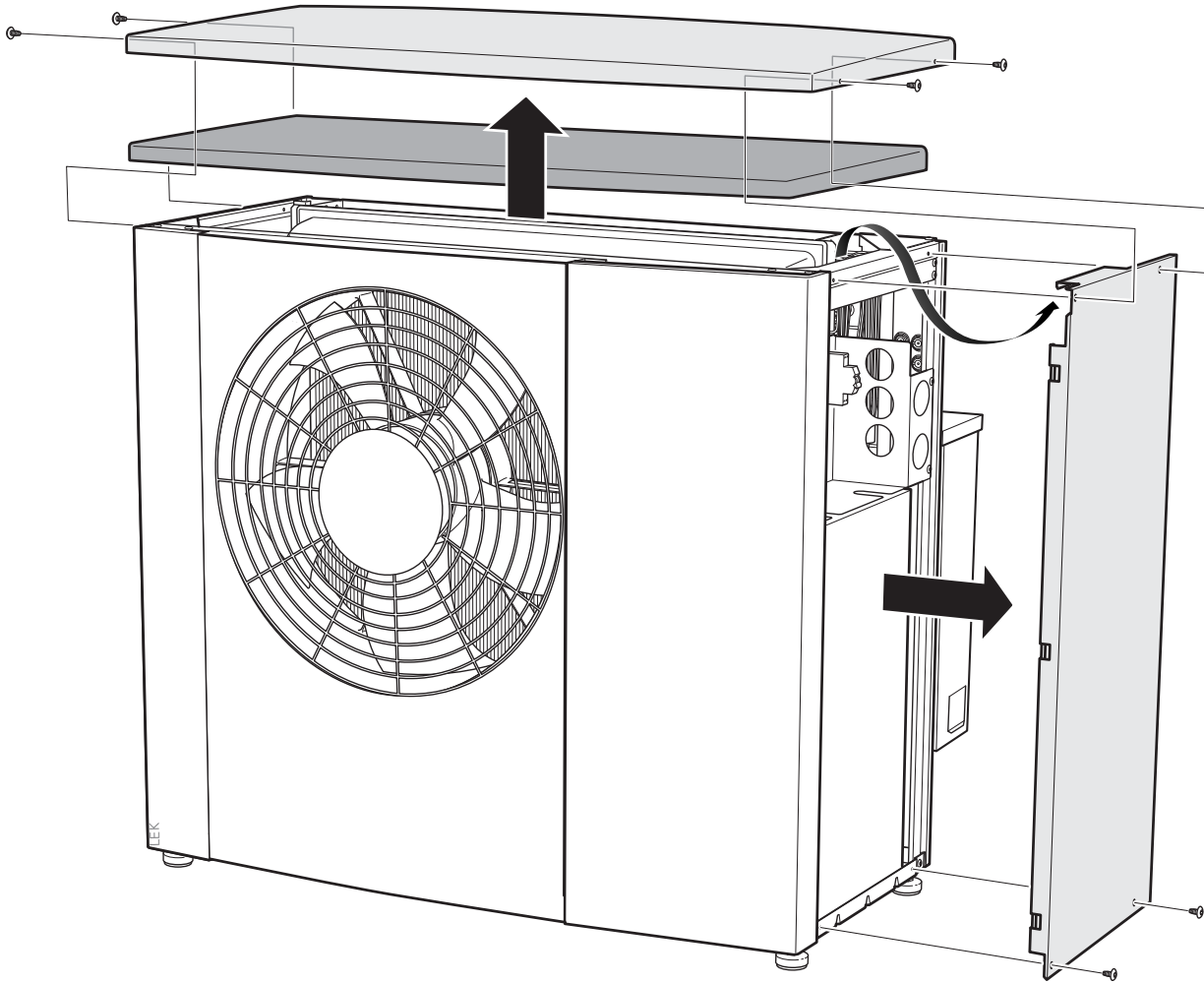

Installation of automatic gas separator

The automatic gas separator and the safety valve should always be installed as instructed below.

1. Check that all O-rings are present and that they are undamaged. Lubricate them with soapy water or similar to make installation easier.

Press the gas separator into place. Fit the clip. Twist the clip to ensure that it fastens properly.

Place the bracket in position, parallel with the outer edge. Secure the bracket with a screw. Use a socket wrench, size 10 mm.

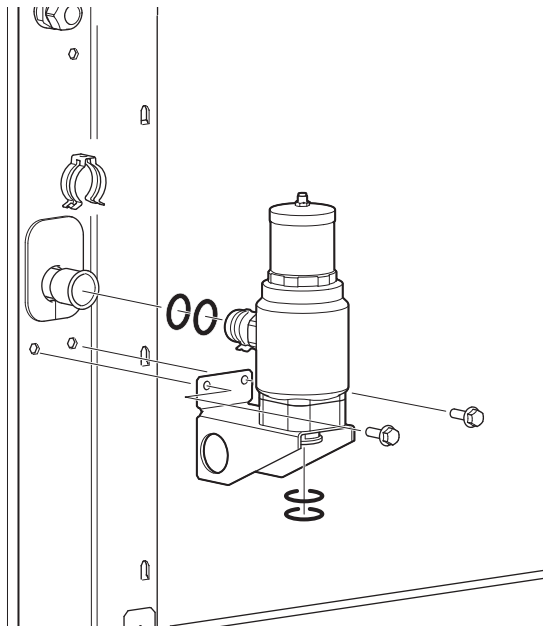

2. Assemble the parts of the safety valve. Ensure that the arrow for the outlet is pointing down, as illustrated.

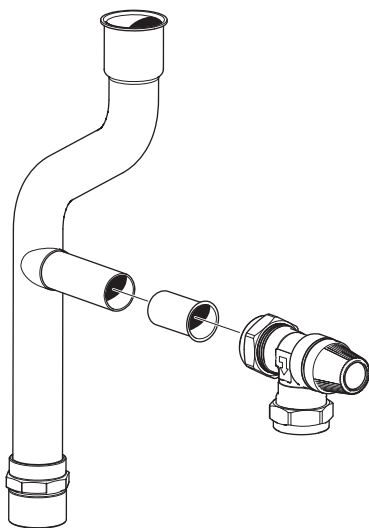

3. Then fit the safety valve with the associated pipes. The safety valve must be at an angle of 45°. Fit the clip. Twist the clip to ensure that it fastens properly.

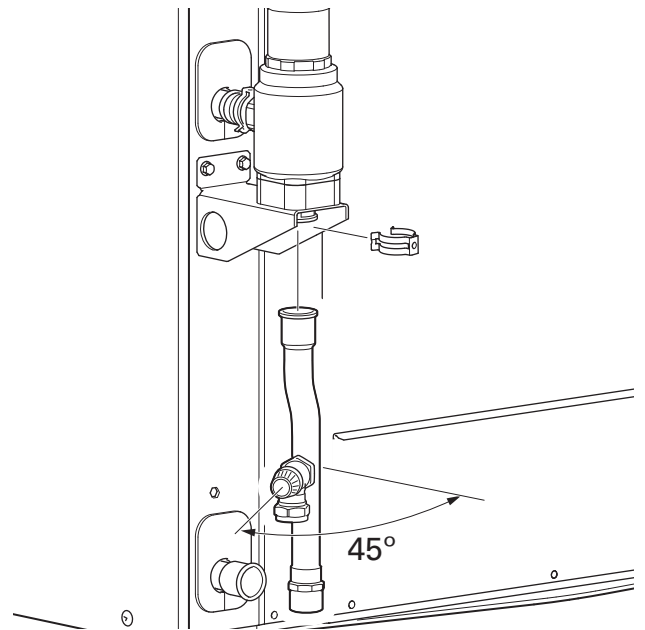

4. Install the non-return valve. Fit the clip. Twist the clip to ensure that it fastens properly.

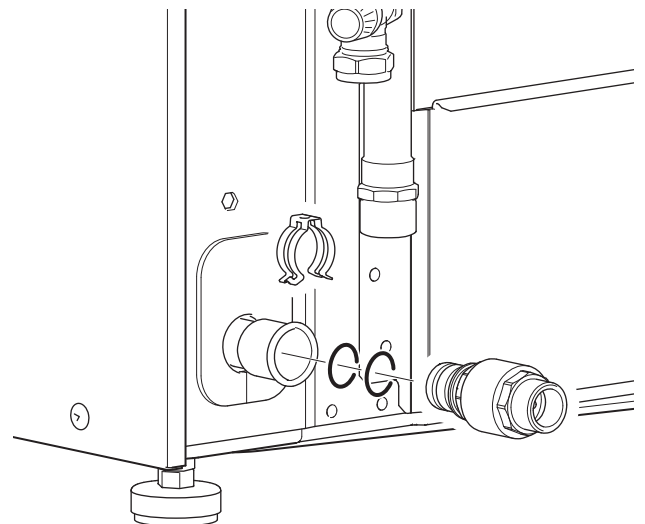

5. Install the right-hand side of the metal box. The lug in the insulation must go into the round hole in the bracket.

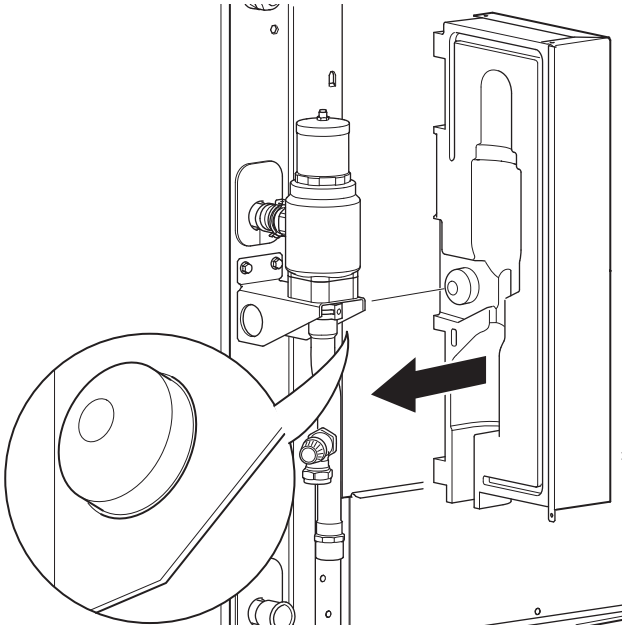

7. Check that both halves of the gas separator are properly in place, parallel with the edge of the heat pump.

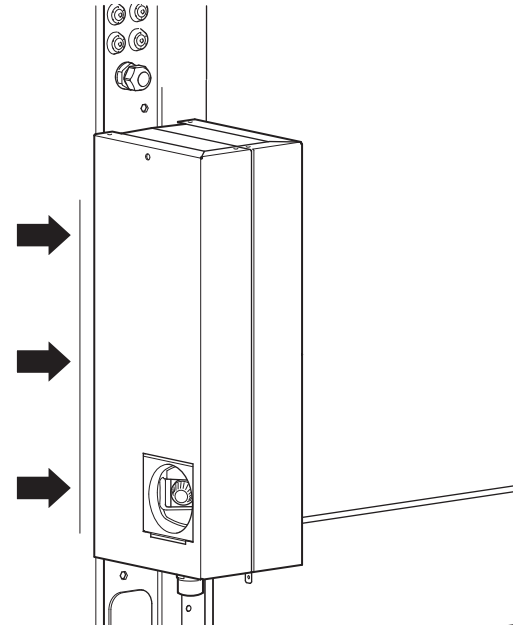

6. Fit the left-hand side in the same way.

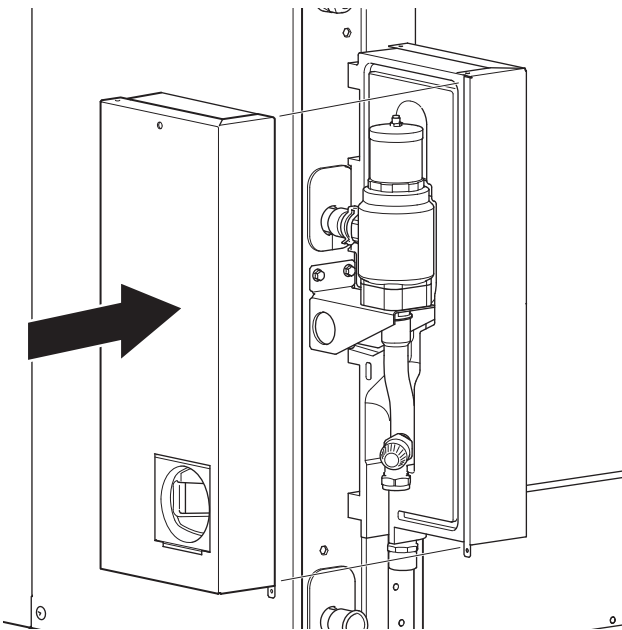

8. Fit the cover. Secure with three screws. Two screws in the lid, on the right and left-hand sides, and one screw in the bottom.

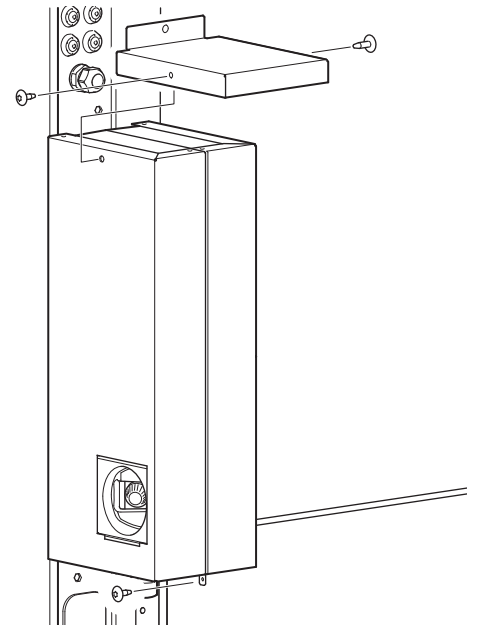

- Secure the gas separator to the heat pump using two screws, one at the top and one at the bottom.

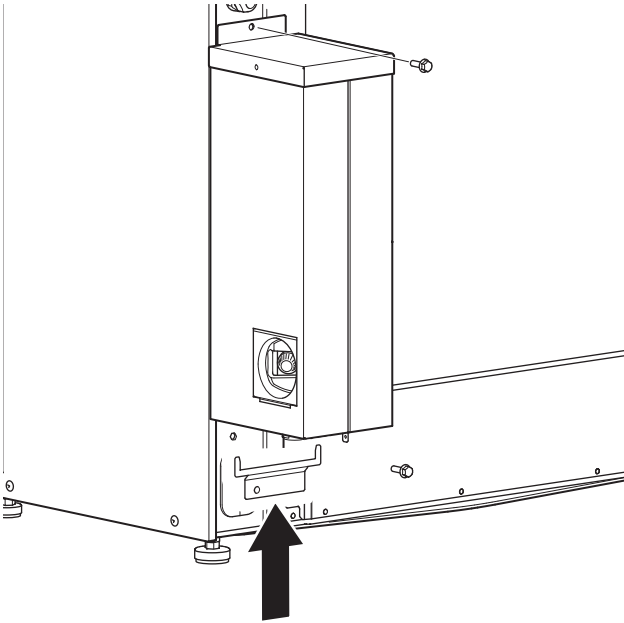

- Install the lid that conceals the safety valve.

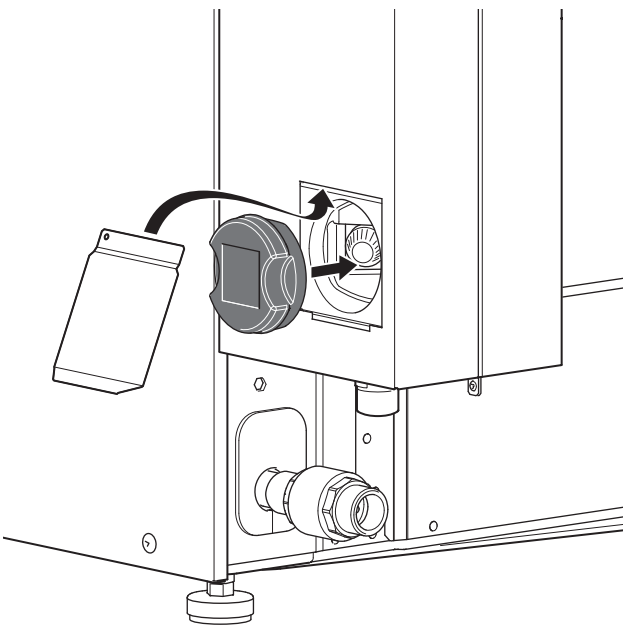

- Screw the flexible pipes into place. The flexible pipes can be installed angled straight back or down, depending on which of the pipe connections the 90° bend is in-

stalled on. Install the flexible pipes with a slight bend, so they can absorb any vibrations that would otherwise be propagated through the building.



NOTE

Don't forget the flat gaskets.

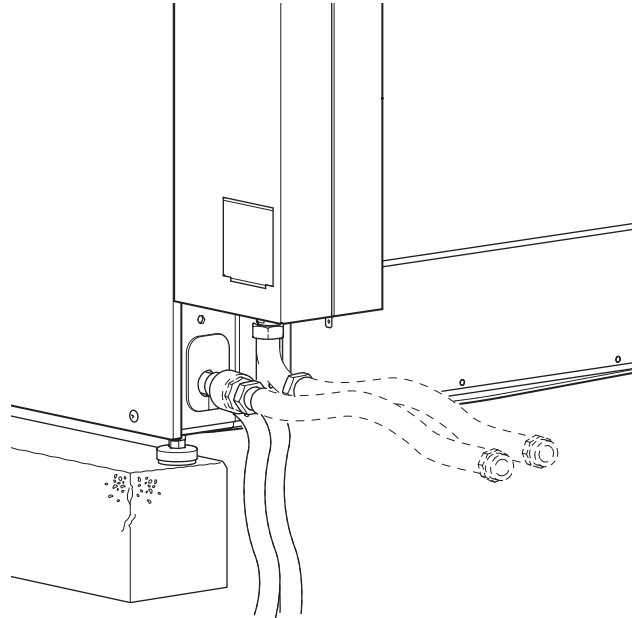

- Check that the venting opening is not covered with pipe insulation. Pipe insulation should extend as far as the coupling and must not cover the opening.

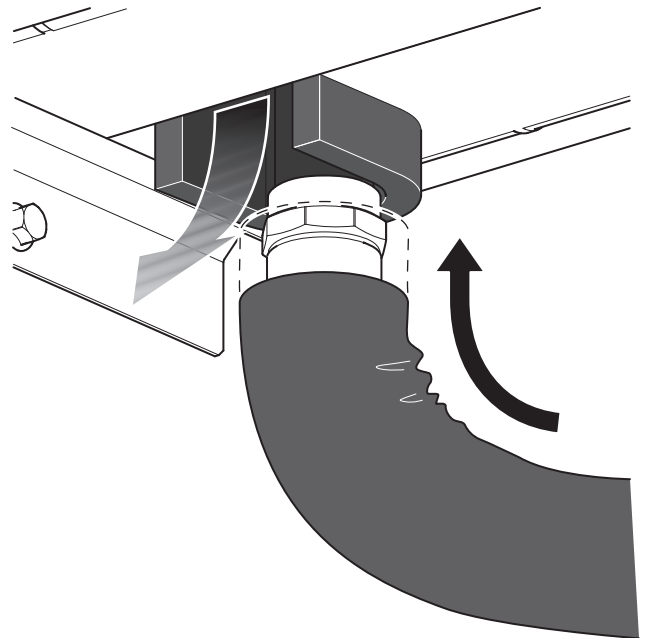

The heat pump design

General

S2125 (1x230V)

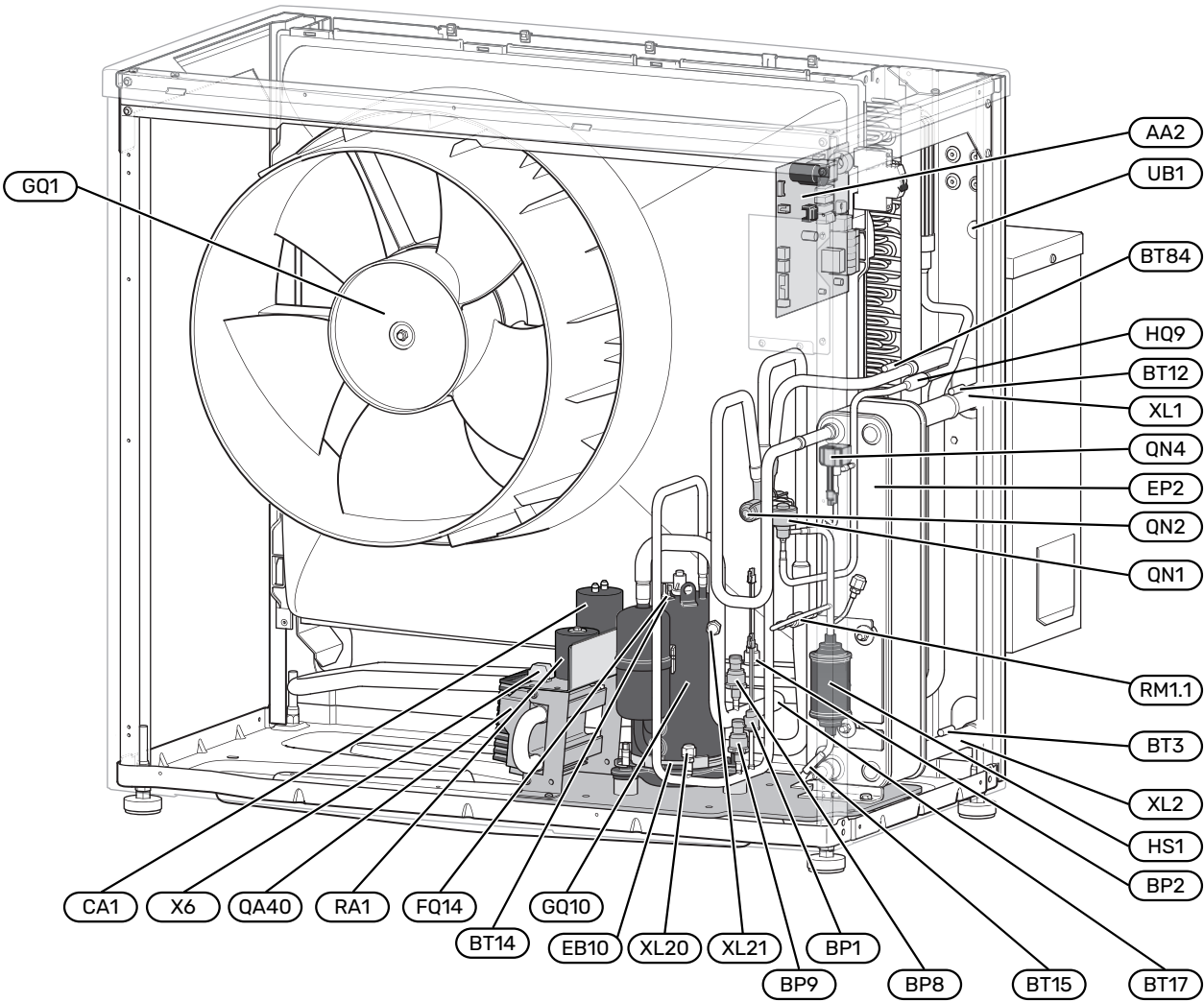

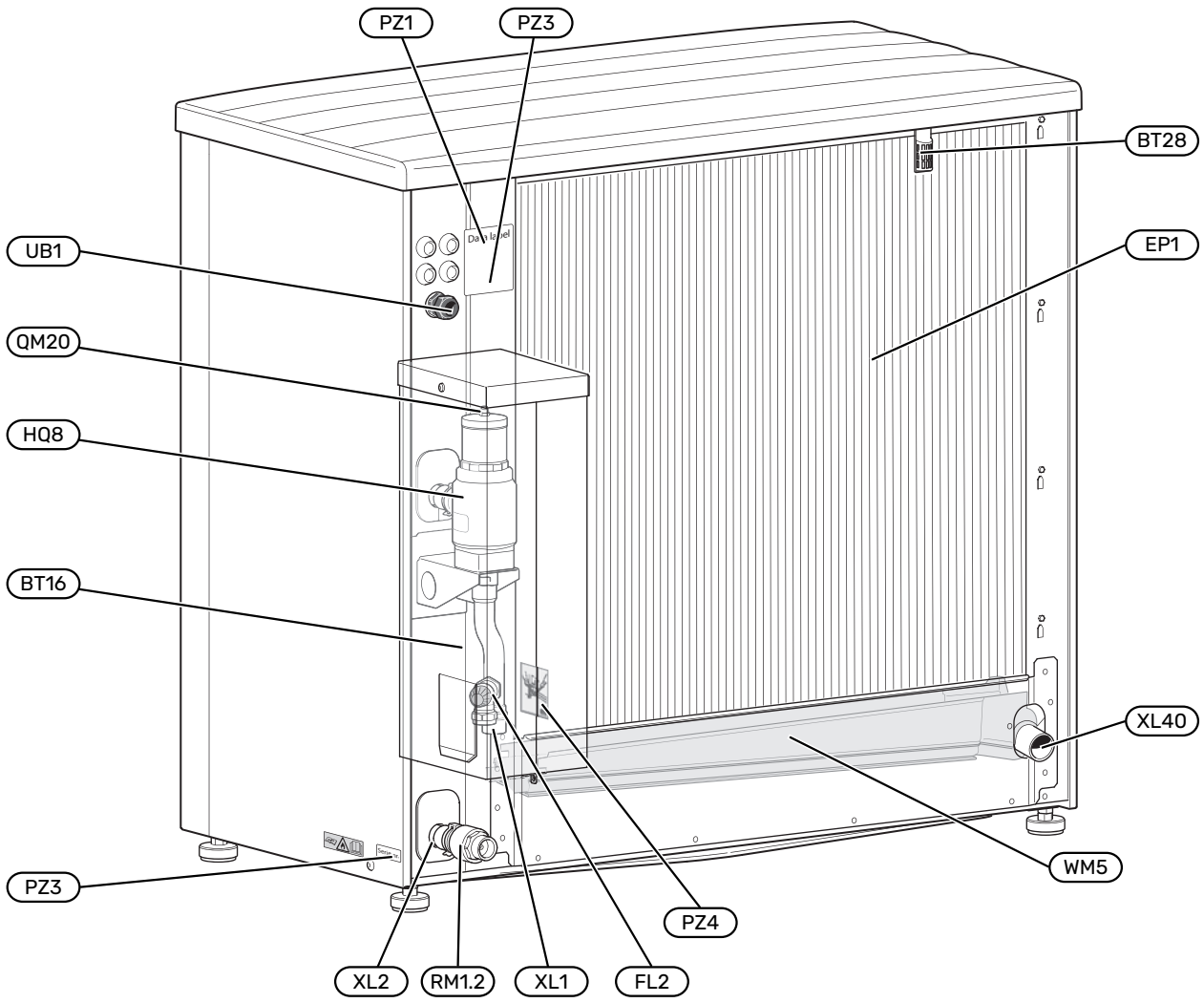

PIPE CONNECTIONS

XL1	Heating medium connection, supply (from S2125)
XL2	Heating medium connection, return (to S2125)
XL20	Service connection, high pressure
XL21	Service connection, low pressure
XL40	Connection, drain condensation water trough

HVAC COMPONENTS

FL2	Safety valve, heating medium
HQ8	Automatic gas separator ¹
RM1.2	Non-return valve ¹
QM20	Vent valve, heating medium
WM5	Condensation water trough

¹ Enclosed (not factory-fitted).

SENSORS ETC.

BP1	High pressure pressostat
BP2	Low pressure pressostat
BP8	Low pressure transmitter
BP9	High pressure sensor
BT3	Temperature sensor, return
BT12	Temperature sensor, condenser supply line
BT14	Temperature sensor, hot gas
BT15	Temperature sensor, fluid pipe
BT16	Temperature sensor, evaporator
BT17	Temperature sensor, suction gas
BT28	Temperature sensor, ambient
BT84	Temperature sensor, suction gas evaporator

ELECTRICAL COMPONENTS

AA2	Base card
AA13	Triac board
CA1	Capacitor (1x230V)
EB10	Compressor heater
FQ14	Temperature limiter, compressor
GQ1	Fan
QA40	Inverter
RA1	Choke (1x230V)
X6	Terminal block (1x230V)

COOLING COMPONENTS

EP1	Evaporator
EP2	Condenser
GQ10	Compressor
HQ9	Particle filter
HS1	Drying filter
QN1	Expansion valve
QN2	4-way valve
QN4	Bypass valve
RM1.1	Non-return valve

MISCELLANEOUS

PZ1	Type plate
PZ3	Serial number
PZ4	Sign, pipe connections
UB1	Cable gland, incoming supply

Designations according to standard EN 81346-2.

Distribution box

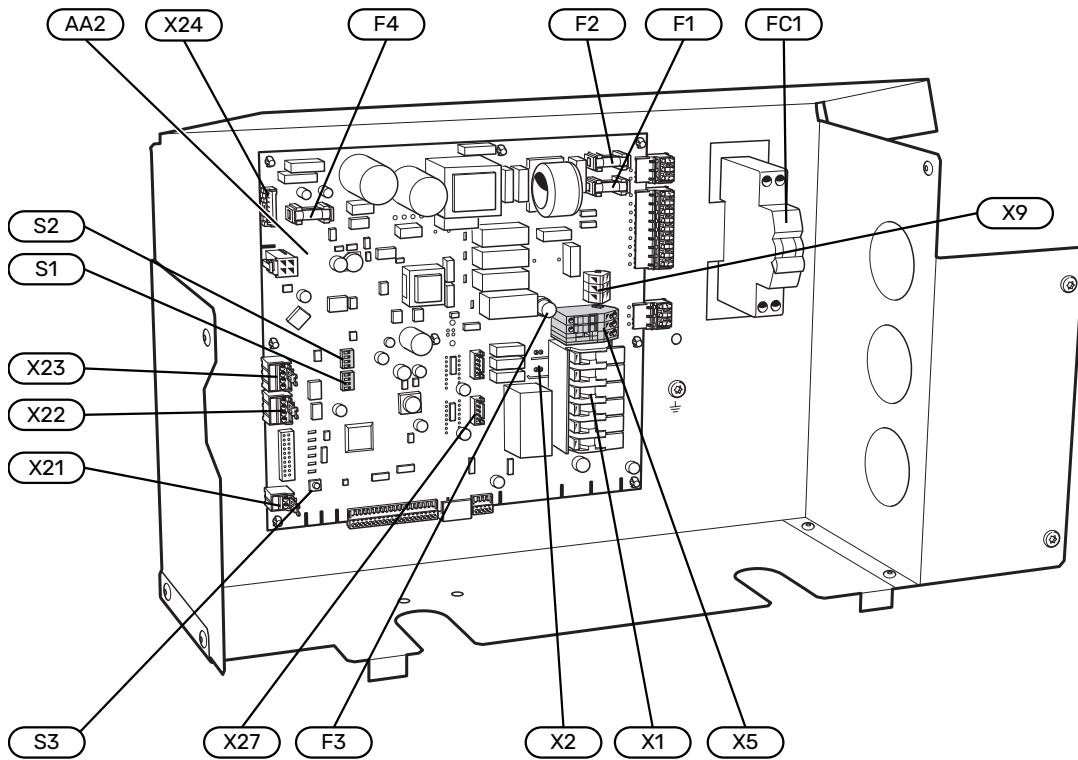

ELECTRICAL COMPONENTS

AA2	Base card
X1	Terminal block, incoming supply
X2	Terminal block, compressor supply
X5	Terminal block, external control voltage
X9	Terminal block, connection KVR
X21	Terminal block, Compressor blocking, Tariff
X22	Terminal block, communications
X23	Terminal block, communications
X24	Terminal block, fan
X27	Terminal block, expansion valve QN1
F1	Fuse, operating 230V~, 4A
F2	Fuse, operating 230V~, 4A
F3	Fuse for external heating cable, KVR, 250mA
F4	Fuse, fan, 4A
FC1	Miniature circuit-breaker (Replaced with automatic protection (FB1) when installing accessory KVR 11.)
S1	DIP switch, addressing heat pump during multi operation
S2	DIP switch, different options
S3	Reset button

Sensor placement

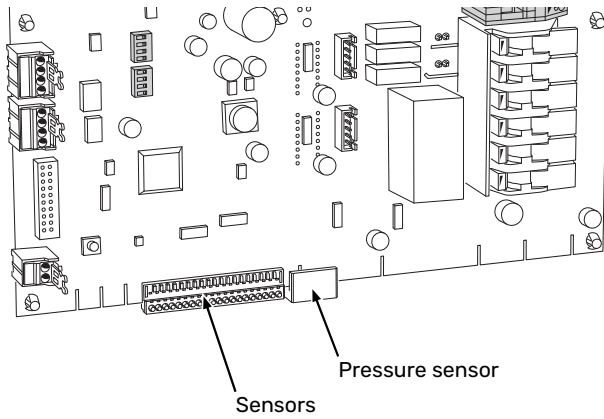

- BP8 Low pressure transmitter
- BP9 High pressure sensor
- BT3 Temperature sensor, return
- BT12 Temperature sensor, condenser supply line
- BT14 Temperature sensor, hot gas
- BT15 Temperature sensor, fluid pipe
- BT16 Temperature sensor, evaporator
- BT17 Temperature sensor, suction gas
- BT28 Temperature sensor, ambient
- BT84 Temperature sensor, suction gas, evaporator

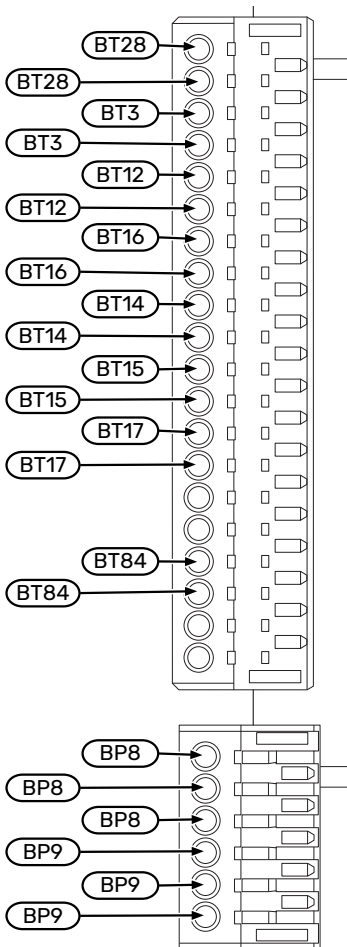

Pipe connections

General

Pipe installation must be carried out in accordance with current norms and directives.

The pipe dimension should not be less than the recommended pipe diameter according to the table. However, each system must be dimensioned individually to manage the recommended system flows.

MINIMUM SYSTEM FLOWS

The installation must be dimensioned to manage at least the minimum defrosting flow at 100% pump operation, see table.

Air/water heat pump	Minimum flow during defrosting (100% pump speed (l/s))	Minimum recommended pipe dimension (DN)	Minimum recommended pipe dimension (mm)
S2125-8 (1x230V)	0.32	25	28
S2125-8 (3x400V)			
S2125-12 (1x230V)			
S2125-12 (3x400V)			

 **NOTE**
An undersized system can result in damage to the product and lead to malfunctions.

S2125 can only operate up to a return temperature of about 65 °C and an outgoing temperature of about 75 °C from the heat pump.

S2125 is not equipped with shut-off valves on the heating medium side, rather these must be installed to facilitate any future servicing. The return temperature is limited by the return line sensor.

 **NOTE**
This installation is subject to building regulation approval, notify the local Authority of intention to install.

 **NOTE**
Use only manufacturer's recommended replacement parts.

HARD WATER AREAS

Normally, there should not normally be any problem installing S2125 in hard water areas, as the operating temperature is 50–60°C.

CLEANING THE CLIMATE SYSTEM

When the water heater and the climate system have been filled with water, S2125 must operate at maximum normal temperature for at least one hour. Thereafter the system must be drained of water and refilled.

Before installing the heat pump in an existing system, it is important that the system is properly flushed through.

Even if the heat pump is to be installed in a new system, the heat pump and system should be flushed.



NOTE

Ensure that cleaning agent has been removed from the entire system before adding inhibitor.

After flushing an inhibitor should be used for long-term anti-corrosion protection.

NIBE Energy Systems Limited recommends water treatments (supplied by e.g. Fernox and Sentinel) specifically designed for heat pumps.

WATER VOLUMES













To avoid short operating times and to enable defrosting, a certain available water volume is required. For the optimum operation of S2125, a minimum available water volume of 120 litres is recommended. This applies separately to heating and cooling systems.



NOTE

The pipe installation must be flushed out before the heat pump is connected so debris cannot damage component parts.

Symbol key

Symbol	Meaning
	Shut-off valve
	Circulation pump
	Expansion vessel
	Filterball
	Pressure gauge
	Safety valve
	Trim valve
	Reversing valve/shunt
	Control module
	Air/water heat pump
	Radiator system
	Domestic hot water
	Water heater

Pipe coupling heating medium circuit

You can find a list of compatible products in the section "Compatible indoor modules (VVM) and control modules (SMO)".

Caution

There is a difference between connection to a control module compared with connection to an indoor module.

See the Installer Manual for the indoor module/control module.

The heat pump is vented automatically with the aid of the gas separator (HQ8). The gas separator closes automatically when the valve housing has been vented and filled with liquid.

Install as follows:

- expansion vessel
- pressure gauge
- pressure relief valve
- charge pump
- shut-off valve

To facilitate any future servicing.

- enclosed filterball (QZ2)

Installed before connection "heating medium return" (XL2) (the lower connection) on the vacuum pump.

- reversing valve.

When connecting to the control module, and if the system is to be able to work with both the climate system and the hot water heater.

- trim valve

When connecting to control module and hot water heater.

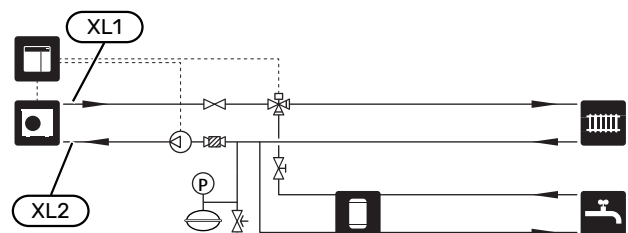

The image shows connection to the control module.

CHARGE PUMP

The charge pump (not included in the product) is powered and controlled from the indoor module/control module. It has a built-in frost protection function and, for this reason, must not be switched off when there is a risk of freezing.

At temperatures below +2 °C the charge pump runs periodically, to prevent the water from freezing in the charge circuit. The function also protects against excess temperatures in the charge circuit.

PRESSURE DROP, HEATING MEDIUM SIDE

The diagram shows the pressure drop on the heating medium side, including the gas separator.

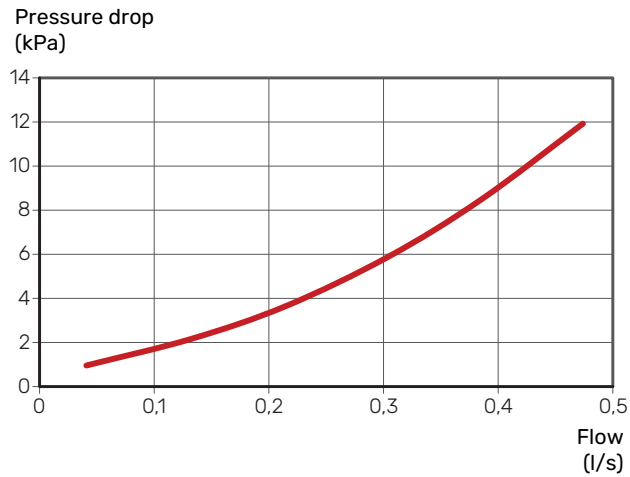

PIPE INSULATION

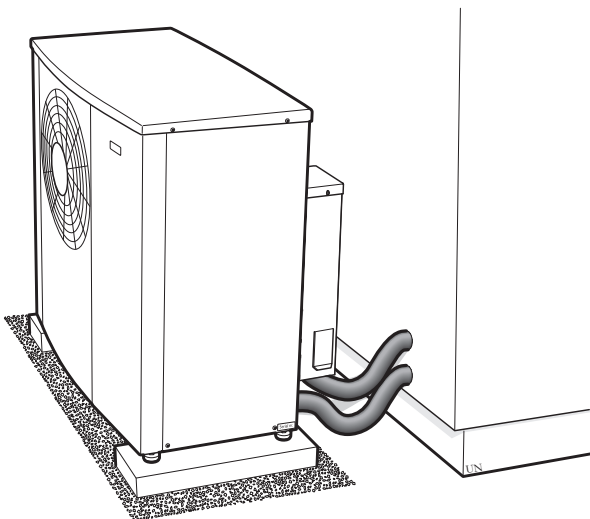

All outdoor pipes must be insulated with at least 19 mm thick pipe insulation.

Electrical connections

General

- Electrical installation and wiring must be carried out in accordance with national provisions.
- Disconnect S2125 before insulation testing the house wiring.
- If a miniature circuit breaker is used, this must have at least triggering characteristic "C". See section "Technical specifications" for fuse size.
- If the building is equipped with an RCD, S2125 must be equipped with a separate one.
- For 230V~ 50Hz, the incoming supply must be 230V~ 50Hz via distribution box with fuses.
- The routing of cables for heavy current and signals should be made out through the cable glands on the heat pump's right-hand side, seen from the front.
- Use a screened cable for communication.
- To prevent interference, sensor cables to external connections must not be laid close to high voltage cables.
- Connect the charge pump to the control module. See where the charge pump is to be connected in the Installer Manual for your control module.



NOTE

Do not start the system before filling up with water. Components in the system could be damaged.

Accessibility, electrical connection

See section "Removing the side panel and top panel".



NOTE

Electrical installation and any servicing must be carried out under the supervision of a qualified electrician. Disconnect the current using the circuit breaker before carrying out any servicing.



NOTE

Check the connections, main voltage and phase voltage before the product is started, to prevent damage to the heat pump electronics.



NOTE

The live external control must be taken into consideration when connecting.



NOTE

If the supply cable is damaged, only NIBE, its service representative or similar authorised person may replace it to prevent any danger and damage.

Connections

POWER CONNECTION

The enclosed cable (length 1.8 m) for incoming electricity is connected to terminal block X1. Outside the heat pump there is approx. 1.8 m of cable available.

Connection 1 x 230 V

X1

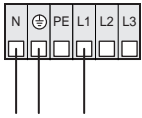

At installation, install the screwed connection on the rear of the heat pump. The part of the screwed joint that tensions the cable must be tightened to a tightening torque above 3.5Nm.

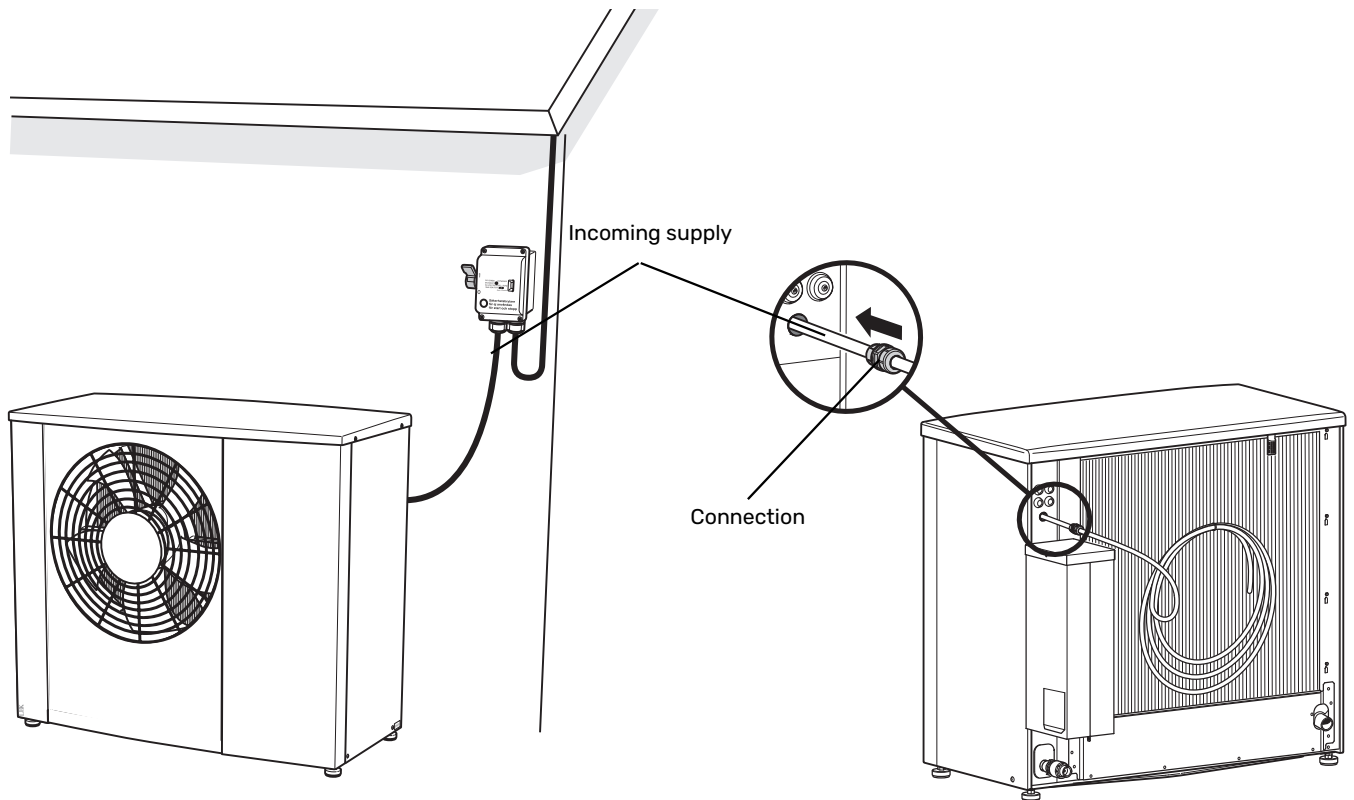

TARIFF CONTROL



NOTE

All supply circuits must be disconnected, because the compressor and the control system may have separate power supplies.

If the control is to be powered separately from other components in the heat pump (e.g. for tariff connection), a separate operating cable must be connected to terminal block (X5).

If external control voltage is used during tariff control, a closing contact must be connected to connection X21:1 and X21:2 (compressor blocking) to prevent an alarm. Compressor blocking must be performed either on the indoor module/control module or on the air/water heat pump, not on both simultaneously.

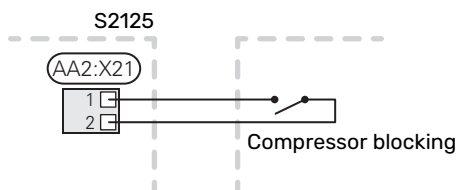

Placement of labels



Caution

These labels should only be placed on the heat pump in those cases where the heat pump has a tariff connection with an external supply voltage.

Two labels should be placed on S2125. The labels are enclosed with the manuals.

The small label is placed on the outside of the side panel.

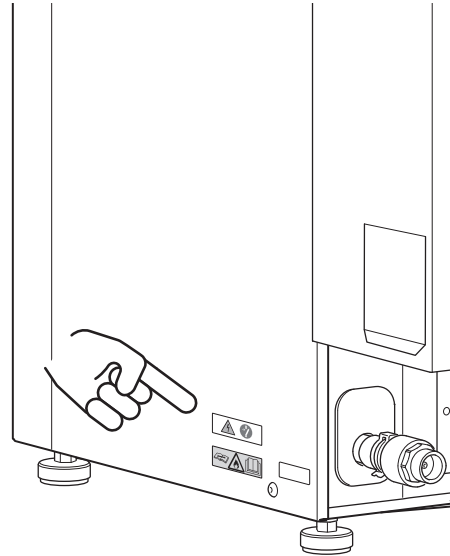

The large label is placed on the inside of the side panel, next to the insulation. See section "Removing the side panel and top panel".

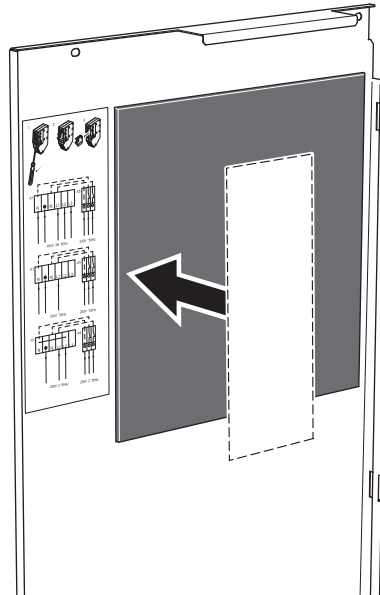

CONNECTING EXTERNAL CONTROL VOLTAGE

When connecting external control voltage, remove the bridges from terminal block X5 (see image).

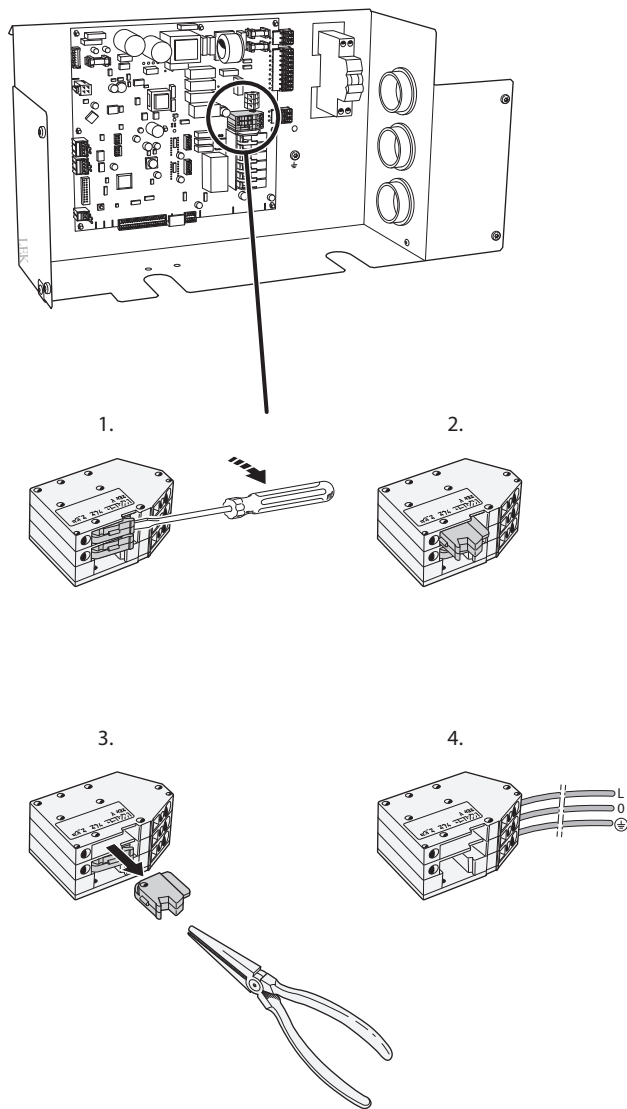

Connect external control voltage (230V~ 50Hz) to terminal block X5:L, X5:N and X5:PE (as illustrated).

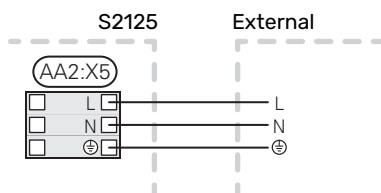

COMMUNICATION

Software version

In order for S2125 to be able to communicate with indoor module (VVM)/control module (SMO), you may need to update to a more recent software version.

Disconnect the connections in S2125

When connecting communication to an indoor module/control module, you need to disconnect the connectors in S2125.

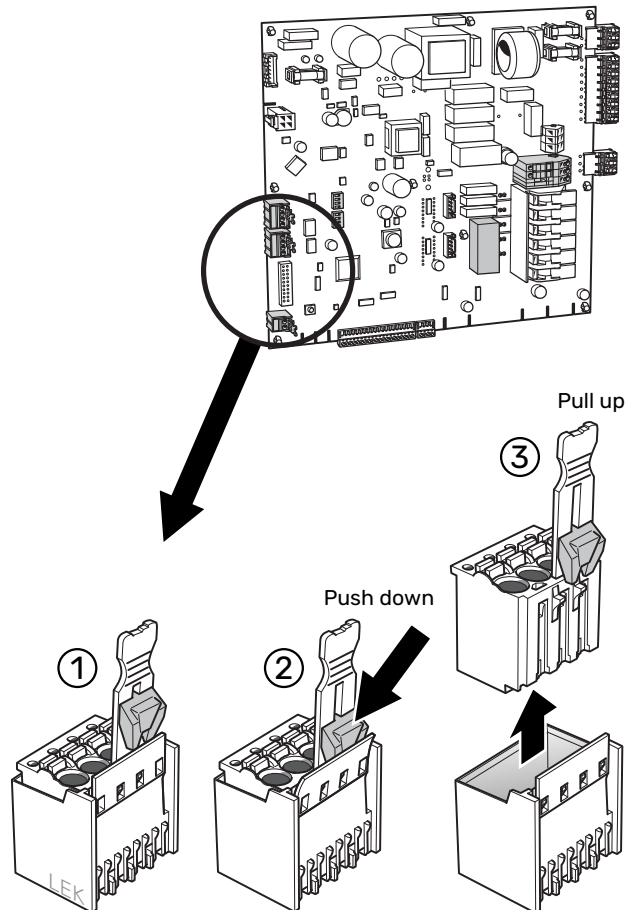

Connection to indoor module/control module

S2125 communicates with NIBE indoor modules/control modules via a screened three-core cable (max area 0.75 mm²) to terminal block X22:1-4.

For connection in the indoor module/control module:

See the Installer Manual for the indoor module/control module.

S2125

S2125

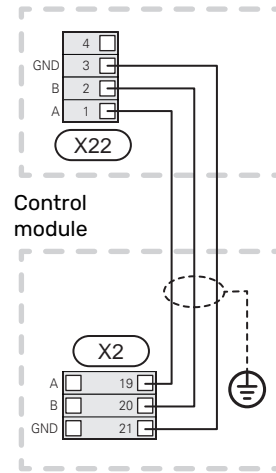

Cascade connection

For cascade connection, connect terminal block X23 with the next heat pump's terminal block X22.

SMO S40

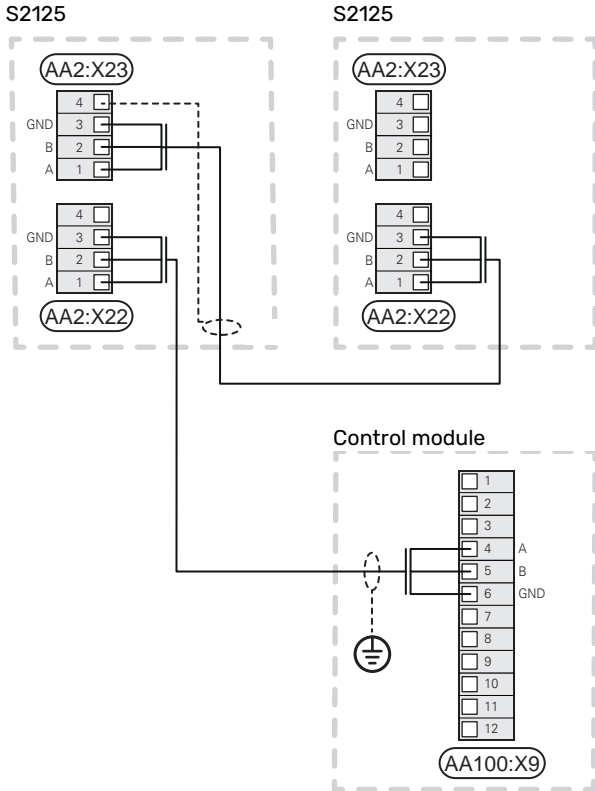

SMO 40

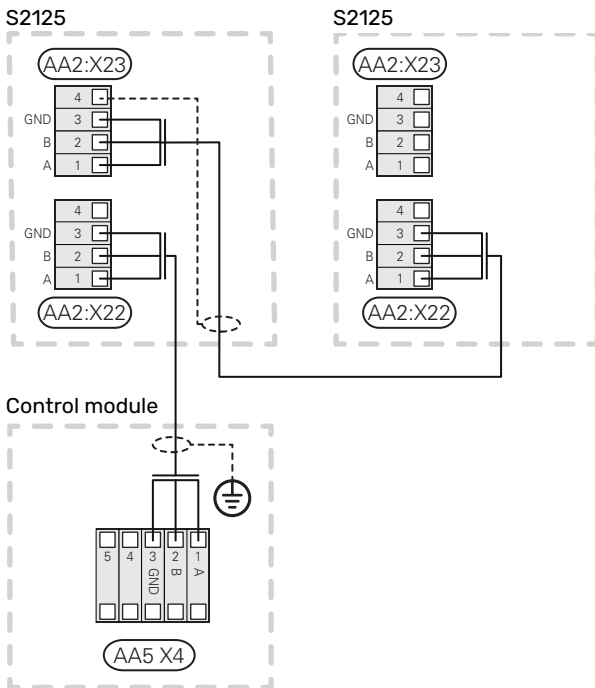

COOLING

S2125 can supply cooling with cooling supply down to +7°C.



Caution

DIP S1 position 4 must be changed to ON in order to run cooling

CONFIGURATION USING DIP SWITCH

The communication address for S2125 to the indoor module / control module is selected on the base board (AA2). DIP switch S1 is used for configuration of address and functions. For cascade operation with SMO for example, addressing is required. S2125 has the address **1** as standard. In a cascade connection all S2125 must have a unique address. The address is coded in binary.



NOTE

Only change the DIP switches position when the product is not powered.

DIP S1 position (1 / 2 / 3)	Slave	Address (com)	Default setting
off / off / off	Slave 1	01	OFF
on / off / off	Slave 2	02	OFF
off / on / off	Slave 3	03	OFF
on / on / off	Slave 4	04	OFF
off / off / on	Slave 5	05	OFF
on / off / on	Slave 6	06	OFF
off / on / on	Slave 7	07	OFF
on / on / on	Slave 8	08	OFF

DIPS1 position	Setting	Function	Default setting
4	ON	Permits cooling	OFF

DIP S2 position	Setting	Default setting
1	OFF	OFF
2	OFF	OFF
3	OFF	OFF
4	OFF	OFF

Switch S3 is the reset button that restarts control.

CONNECTING ACCESSORIES

Instructions for connecting accessories can be found in the installation instructions provided for the respective accessory. See section "Accessories" for a list of the accessories that can be used with S2125.

Commissioning and adjusting

Preparations



Caution

Check the miniature circuit-breaker (FC1). It could have tripped during transport.



NOTE

Do not start S2125 if there is a risk that the water in the system has frozen.



NOTE

At the time of commissioning, complete all relevant sections of the Benchmark Checklist located at the back of this document.

Completion of the Benchmark Checklist is a condition of warranty. For full terms and conditions of warranty, please see our website nibe.co.uk.

COMPRESSOR HEATER

S2125 is equipped with a compressor heater that heats the compressor before start-up and when the compressor is cold.

Compressor heater (EB10) is activated when the heat pump is connected to the supply voltage. The compressor needs to be heated up before starting for the first time. From the time the indoor module/control module is connected and a heating demand arises, it may take a while before the compressor reaches the permitted start value.



NOTE

The compressor heater must have been active for a while, prior to starting for the first time, until the discharge sensor (BT14) has reached its set temperature, see section "Start-up and inspection".

Filling and venting

Fill the heating system to the necessary pressure. The heat pump is equipped with an automatic venting valve, which closes when the heat pump is filled with liquid.

Start-up and inspection

1. Communication cable must be connected.
2. If cooling operation with S2125 is wanted, DIP switch S1 position 4 must be changed according to the description in section "Cooling".
3. Turn the isolator switch on.
4. Ensure that the S2125 is connected to the power source.
5. Check that fuse (FC1) is on.
6. Reinstall the removed panels and cover.
7. After the power to S2125 has been switched on, and there is a compressor demand from the indoor module/control module, the compressor starts once it has warmed up.
8. Adjust the charge flow according to size. Also see section "Adjustment, charge flow".
9. Adjust menu settings via the indoor module/control module as necessary.
10. Fill in "Inspection of the installation", in section "Important information".



NOTE

The live external control must be taken into consideration when connecting.

Post adjustment and venting

Air is initially released from the hot water and venting may be necessary. If bubbling sounds can be heard from the heat pump, the charge pump or radiators, the entire system requires further venting. When the system has stabilised (correct pressure and all air eliminated), the automatic heating control system can be set as required.

Adjustment, charge flow

For correct function of the heat pump over the entire year, the charge flow must be correctly adjusted.

Adjustment may be required, especially for charging a separate water heater. It is therefore recommended to have the option of adjusting the flow across the water heater using a trim valve.

1. Recommendation if there is insufficient hot water and information message "high condenser out" during hot water charging: increase the flow
2. Recommendation if there is insufficient hot water and information message "high condenser in" during hot water charging: reduce the flow

Control

General

S2125 is equipped with an internal electronic controller that handles all functions necessary for operation of the heat pump, e. g. defrosting, stop at max/min temperature, connection of the compressor heater, and protective functions during operation.

The integrated control shows information via status-LEDs and can be used during servicing.

Under normal operating conditions the home owner does not need to have access to the controller.

S2125 communicates with the NIBE indoor module/control module, which means that all settings and measurement values from S2125 are adjusted and read off on the indoor module/control module.



Caution

The main product's software must be the latest version.

LED status

The base board (AA2) has a status LED for easy control and troubleshooting.

LED	State	Explanation
PWR (green)	Not lit	Base board without power
	Continuous light	Base board power on
CPU (green)	Not lit	CPU without power
	Flashes	CPU running
	Continuous light	CPU not running correctly
EXT COM (green)	Not lit	No communication with indoor module/control module
	Flashes	Communication with indoor module/control module
INT COM (green)	Not lit	No communication with inverter
	Flashes	Communication with inverter
DEFROST (green)	Not lit	Neither defrosting nor protection is active
	Flashes	Some protection is active
	Continuous light	Defrosting in progress
ERROR (red)	Not lit	No errors
	Flashes	Info alarm (temporary), active
	Continuous light	Continuous alarm, active
K1, K2, K3, K4, K5	Not lit	Relay in de-energised position
	Continuous light	Relay activated
N-RELAY		No function
COMPR. ON		No function

LED	State	Explanation
PWR-INV (green)	Not lit	Inverter without power
	Continuous light	Inverter has power

HARMONIC FILTER (RA1)

Harmonic filter (RA1) has a status LED for easy control and troubleshooting.

When the capacitor is in operation, LED 201 is lit with a steady light.

LED	State	Explanation
LED 201 (red)	Not lit	Capacitor disconnected
	Continuous light	Capacitor connected

Master control

To control S2125, a NIBE indoor module/control module is required, which calls upon S2125 according to demand. All settings for S2125 are made via the indoor module/control module. It also shows the status and sensor values from S2125.

Description		Value	Parameter space
Cut-out value activation passive defrosting	°C	4	4 - 14
Start temperature BT16 to calculate index	°C	-3	-5 - 5
Permit fan de-icing	(1 / 0)	No	Yes / No
Permit silent mode	(1 / 0)	No	Yes / No
Permit defrost more often	(1 / 0)	No	Yes / No

Control conditions

CONTROL CONDITIONS DEFROSTING

- If the temperature of the evaporator sensor (BT16) is below the start temperature for the defrosting function, S2125 counts the time to "active defrosting" for each minute that the compressor is running, to create a defrosting requirement.
- Time until "active defrosting" is shown in minutes on the indoor module / control module. Defrosting starts when this value is 0 minutes.
- "Passive defrosting" is started, if the compressor requirement has been fulfilled, at the same time as there is a defrosting requirement and the outdoor temperature (BT28) is greater than 4 °C.
- Defrosting occurs actively (with compressor on and fan off) or passively (with compressor off and fan on).
- If the evaporator is too cold, a "safety defrost" starts. This defrosting can start earlier than the normal defrosting. If the safety defrosting occurs ten times in a row, the evaporator (EP1) on S2125 must be checked, which is indicated by an alarm.
- If "de-icing fan" is activated in the indoor module/control module, "de-icing fan" starts at the next "active defrosting". "De-icing fan" removes the build-up of ice on the fan blades and the front fan grille.

Active defrosting:

1. The four way valve shifts to defrosting.
2. The fan stops and the compressor continues to run.
3. When defrosting is complete, the four-way valve switches back to heating operation. The compressor speed is locked for a short period.
4. The ambient temperature is locked and the high return temperature alarm is blocked for two minutes after defrosting.

Passive defrosting:

1. If there is no compressor demand, passive defrosting can start.
2. The four-way valve does not shift.
3. Fan runs at high speed.
4. If there is a compressor demand, passive defrosting stops and the compressor starts.
5. When passive defrosting is complete, the fan stops.
6. The ambient temperature is locked and the high return temperature alarm is blocked for two minutes after defrosting.

Control - Heat pump EB101

S-SERIES - VVM S / SMO S

These settings are made on the display on the indoor module/control module.

Menu 7.3.2 - Installed heat pump

Here, you make specific settings for the installed heat pump.

Silent mode permitted

Setting range: on/off

Max. frequency 1

Setting range: 25 - 120 Hz

Max. frequency 2

Setting range: 25 - 120 Hz

Compressor phase

Setting range S2125 1 x 230 V: L1, L2, L3

Detect compressor phase

Setting range S2125 1 x 230 V: off/on

Current limit

Setting range S2125 1 x 230 V: off/on

Max. current

Setting range S2125 1 x 230 V: 6 - 32 A

blockFreq 1

Setting range: on/off

From frequency

Setting range: 25 - 117 Hz

To frequency

Setting range: 28 - 120 Hz

blockFreq 2

Setting range: on/off

From frequency

Setting range: 25 - 117 Hz

To frequency

Setting range: 28 - 120 Hz

Defrosting

Start manual defrosting

Setting range: on/off

Start temperature for defrost function

Setting range: -3 - 3 °C

Cut-out value activation passive defrosting

Setting range: 2 - 10 °C

Defrost more often

Alternatives: Yes / No

Silent mode permitted: Here, you set whether silent mode is to be activated for the heat pump. Please note that you now have the option to schedule when silent mode will be active.

The function should only be used for limited periods, because S2125 possibly may not reach its dimensioned output.

Detect compressor phase: This shows in which the phase the heat pump has detected whether you have S2125 230V~50Hz. Phase detection normally occurs automatically in connection with start-up of the indoor module/control module. This setting can be changed manually.

Current limitation: Here, you set whether the current limitation function will be activated for the heat pump, if you have S2125 230V~50Hz. During active function, you can limit the value of the maximum current.

BlockFreq 1: Here, you can select a frequency range within which the heat pump is not permitted to work. This function can be used if certain compressor speeds cause noise disturbance in the house.

BlockFreq 2: Here, you can select a frequency range within which the heat pump is not permitted to work.

Defrosting: Here, you can change the settings that affect the defrost function.

Start manual defrosting: Here, you can start "active defrosting" manually, if the function needs to be tested for servicing or if necessary. This can also be used to accelerate the start of "fan de-icing".

Start temperature for defrost function: Here, you set the temperature (BT16) at which the defrost function will start. The value must only be changed in consultation with the installer.

Cut-out value activation passive defrosting: Here, you set the temperature (BT28) at which "passive defrosting" will be activated. During passive defrosting, the ice is melted by the energy from the ambient air. The fan is active during passive defrosting. The value must only be changed in consultation with the installer.

Defrost more often: Here, you activate whether defrosting will occur more frequently than normal. This selection can be made if the heat pump receives an alarm due to build-up of ice during operation caused, for example, by snow.

Menu 4.11.3 - Fan de-icing

Fan de-icing

Setting range: off/on

Continuous fan de-icing

Setting range: off/on

Fan de-icing: Here, you set whether the "fan de-icing" function will be activated during the next "active defrosting". This can be activated if ice/snow sticks to the fan, grille or fan cone, which may be noticed due to abnormal fan noise from S2125.

"Fan de-icing" means that the fan, grille and fan cone are heated using hot air from the evaporator (EP1).

Continuous fan de-icing: There is the option to set recurring de-icing. In this case, every tenth defrosting will be "Fan de-icing". (This can increase annual energy consumption.)

F-SERIES – VVM / SMO

These settings are made on the display on the indoor module/control module.

Menu 5.11.1.1 - heat pump

Here, you make specific settings for the installed heat pump.

Silent mode permitted

Setting range: yes / no

Detect compressor phase

Setting range S2125 1 x 230 V: off/on

Current limit

Setting range: 6 – 32 A

Factory setting: 32 A

blockFreq 1

Setting range: yes / no

blockFreq 2

Setting range: yes / no

Defrosting

Start manual defrosting

Setting range: on/off

Start temperature for defrost function

Setting range: -3 – 3 °C

Factory setting: -3 °C

Cut-out value activation passive defrosting

Setting range: 2 – 10 °C

Factory setting: 4 °C

Defrost more often

Setting range: Yes / No

Silent mode permitted: Here, you set whether silent mode is to be activated for the heat pump. Please note that you now have the option to schedule when silent mode will be active.

The function should only be used for limited periods, because S2125 possibly may not reach its dimensioned output.

Detect compressor phase: This shows in which the phase the heat pump has detected whether you have S2125 230V-50Hz. Phase detection normally occurs automatically in connection with start-up of the indoor module/control module. This setting can be changed manually.

Current limitation: Here, you set whether the current limitation function will be activated for the heat pump, if you have S2125 230V-50Hz. During active function, you can limit the value of the maximum current.

BlockFreq 1: Here, you can select a frequency range within which the heat pump is not permitted to work. This function can be used if certain compressor speeds cause noise disturbance in the house.

BlockFreq 2: Here, you can select a frequency range within which the heat pump is not permitted to work.

Defrosting: Here, you can change the settings that affect the defrost function.

Start manual defrosting: Here, you can manually start an "active defrosting", if the function needs to be tested for servicing or if necessary. This can be justified together with "fan de-icing".

Start temperature for defrost function: Here, you set the temperature (BT16) at which the defrost function will start. The value must only be changed in consultation with the installer.

Cut-out value activation passive defrosting: Here, you set the temperature (BT28) at which "passive defrosting" will be activated. During passive defrosting, the ice is melted by the energy from the ambient air. The fan is active during passive defrosting. The value must only be changed in consultation with the installer.

Defrost more often: Here, you activate whether defrosting will occur more frequently than normal. This selection can be made if the heat pump receives an alarm due to build-up of ice during operation caused, for example, by snow.

Menu 4.9.7 - tools

Fan de-icing

Setting range: off/on

Continuous fan de-icing

Setting range: off/on

Fan de-icing: Here, you set whether the "fan de-icing" function will be activated during the next "active defrosting". This can be activated if ice/snow sticks to the fan, grille or fan cone, which may be noticed due to abnormal fan noise from S2125.

"Fan de-icing" means that the fan, grille and fan cone are heated using hot air from the evaporator (EP1).

Continuous fan de-icing: There is the option to set recurring de-icing. In this case, every tenth defrosting will be "Fan de-icing". (This can increase annual energy consumption.)

Service

Service actions



NOTE

Servicing should only be carried out by persons with the necessary expertise.

When replacing components on S2125 only replacement parts from NIBE may be used.



NOTE

If an electrical connection has been disconnected and is connected, ground must be checked using a suitable multimeter.



NOTE

An immersion heater without a temperature limiter is not allowed to be installed.



NOTE

After servicing, complete the relevant Service Interval Record section of the Benchmark Checklist located at the back of this document.

Completion of the Service Interval Record is a condition of warranty. For full terms and conditions of warranty, please see our website nibe.co.uk.

DRAINING THE CONDENSER

In the event of a prolonged power failure or similar, for example, the condenser in S2125 may need to be drained of water.



NOTE

There may be some hot water when draining the heating medium side/climate system. There is a risk of scalding.

1. Close the shut-off valves.
2. Release the pressure using the vent valve (QM20) on the automatic gas separator (HQ8).
3. Release the clip and pull out the non-return valve (RM1.2) on the heating medium connection, return (to S2125) (XL2).

TEMPERATURE SENSOR DATA

Return line (BT3), condenser supply (BT12), liquid line (BT15)

Temperature (°C)	Resistance (kOhm)	Voltage (VDC)
-10	56.20	3.047
0	33.02	2.889
10	20.02	2.673
20	12.51	2.399
30	8.045	2.083
40	5.306	1.752
50	3.583	1.426
60	2.467	1.136
70	1.739	0.891
80	1.246	0.691

Discharge sensor (BT14)

Temperature (°C)	Resistance (kOhm)	Voltage (V)
40	118.7	4.81
45	96.13	4.77
50	78.30	4.72
55	64.11	4.66
60	52.76	4.59
65	43.64	4.51
70	36.26	4.43
75	30.27	4.33
80	25.38	4.22
85	21.37	4.10
90	18.07	3.97
95	15.33	3.83
100	13.06	3.68
105	11.17	3.52
110	9.59	3.36
115	8.26	3.19
120	7.13	3.01

Evaporator sensor (BT16), ambient sensor (BT28), suction gas sensor (BT17) and suction gas, evaporator (BT84)

Temperature (°C)	Resistance (kOhm)	Voltage (VDC)
-40	43.34	4.51
-30	25.17	4.21
-20	15.13	3.82
-10	9.392	3.33
0	6.000	2.80
10	3.935	2.28
20	2.644	1.80
30	1.817	1.39
40	1.274	1.07

Servicing and maintenance

Important

The NIBE heat pump requires minimal maintenance but to ensure the continued efficient running of your heat pump and guarantee in the warranty period it is recommended that it is checked and serviced annually by a qualified engineer.

Any servicing must be carried out by a competent person.

When replacing a part on the appliance, use only spare parts supplied by NIBE.

If any electrical connections have been disconnected and re-connected, checks for earth continuity must be tested for with a suitable multimeter.

On completion the Benchmark service record should be completed.

General inspection

Check the following:

1. Condition of casing
2. Check Inlet grille is not clogged with leaves
3. Check fan for any obstructions
4. Electrical supply connections
5. Water connections
6. Heating system pressure
7. Alarm log

Correct any fault before continuing.



NOTE

Before removing any covers or replacing parts the heat pump must be isolated from the mains electrical supply.



NOTE

After servicing, complete the relevant Service Interval Record section of the Benchmark Checklist located at the back of this document.

Completion of the Service Interval Record is a condition of warranty. For full terms and conditions of warranty, please see our website nibe.co.uk.

Heating System

1. Inspect start and stop temperatures. Correct if required.
2. Inspect heat curve (SMO & VVM only). Correct if required.
3. Check the heating system flow temperatures, the difference should be between 5-10°C. Adjust flow if required.
4. Inspect the heat pump charge flow temperature difference against charge flow with graphs on page 24. Adjust if required.

Disturbances in comfort

In most cases, the indoor module/control module notes a malfunction (a malfunction can lead to disturbance in comfort) and indicates this with alarms and action instructions in the display.

Troubleshooting



NOTE

In the event of action to rectify malfunctions that require work within screwed hatches, the incoming supply electricity must be isolated at the safety switch by or under the supervision of a qualified electrician.



Caution

Alarms are acknowledged on the indoor module / control module (VVM / SMO).

If the operational interference is not shown in the display the following tips can be used:

BASIC ACTIONS

Start by checking the following:

- All supply cables to the heat pump are connected.
- Group and main fuses of the accommodation.
- The property's earth circuit breaker.
- The heat pump's fuse / automatic protection. (FC1 / FB1, FB1 only if KVR is installed.)
- The indoor module's/control module's fuses.
- The indoor module's/control module's temperature limiters.
- That the air flow to S2125 is not blocked by foreign objects.
- That S2125 does not have any external damage.

S2125 DOES NOT START

- There is no demand.
 - The indoor module/control module does not call on heating, cooling or hot water.
- Compressor blocked due to the temperature conditions.
 - Wait until the temperature is within the product's working range.
- Minimum time between compressor starts has not been reached.
 - Wait for at least 30 minutes and then check if the compressor has started.
- Alarm tripped.
 - Follow the display instructions.

S2125 NOT COMMUNICATING

- Check that S2125 is correctly installed in the indoor module (VVM) or the control module (SMO).
- Check that the communication cable is correctly connected and working.

LOW HOT WATER TEMPERATURE OR A LACK OF HOT WATER



Caution

The hot water is always set on the indoor module (VVM) or the control module (SMO).

This part of the fault-tracing chapter only applies if the heat pump is docked to the hot water heater.

- Large hot water consumption.
 - Wait until the hot water has heated up.
- Incorrect hot water settings in indoor module or control module.
 - See the Installer Manual for the indoor module/control module.
- Clogged particle filter.
 - Switch off the system. Check and clean the particle filter.

LOW ROOM TEMPERATURE

- Closed thermostats in several rooms.
 - Set the thermostats to max in as many rooms as possible.
- Incorrect settings in indoor module or control module.
 - See the Installer Manual for the indoor module/control module.
- Air-filled radiators/underfloor heating coils.
 - Bleed the system.

HIGH ROOM TEMPERATURE

- Incorrect settings in indoor module or control module.
 - See the Installer Manual for the indoor module/control module.

ICE BUILD-UP IN THE FAN, GRILLE AND/OR FAN CONE ON S2125

- Activate "fan de-icing" in the indoor module/control module. Alternatively "continuous fan de-icing" if the problem recurs.
- Check that the air flow across the evaporator is correct.

LARGE AMOUNT OF WATER BELOW S2125

- The accessory KVR 11 is required.
- If KVR 11 is installed, check that the water drainage flows freely.

ACTIVE DEFROSTING IS TERMINATED

There are several possible reasons for an active defrosting to end:

- If the temperature of the evaporator sensor has reached its stop value (normal stop).
- When defrosting has gone on for longer than 15 minutes. This may be due to too little energy in the heat source, too strong a wind effect on the evaporator and/or that the sensor on the evaporator is not correct and therefore displays too low a temperature (at cold outdoor air).
- When the temperature on the return line sensor, BT3, falls below 10 °C.
- If the temperature of the evaporator (BP8) falls below its lowest permitted value. After failing to defrost ten times, S2125 must be checked. This is indicated by an alarm.

Alarm list

Alarms VVM/SMO (S2125)	Alarms S-series	Alarm text on the display	Description existing alarm	May be due to
156 (80)	212	Low lp cooling	5 repeated alarms for low low-pressure within 4 hours.	Poor flow. Significant wind effect.
224 (182)	233	Fan alarm from heat pump	5 unsuccessful start attempt.	Fan blocked or not connected.
225 (8)	234	Exchange Sensors flow / return	Return is hotter than flow.	Connection, supply line return line switched around,
227 (34)	530	Sensor fault from heat pump	Sensor fault BT3.	Open-circuit or short-circuit on sensor input.
227 (36)	531		Sensor fault BT12.	
227 (38)	532		Sensor fault BT14.	
227 (40)	533		Sensor fault BT15.	
227 (42)	534		Sensor fault BT16.	
227 (44)	535		Sensor fault BT17.	
227 (46)	536		Sensor fault BT28.	
227 (50)	538		Sensor fault BP8.	
227 (52)	539		Sensor fault BP9.	
227 (56)	541		Sensor fault BT84.	
228 (2)	236	Unsuccessful defrosting	10 failed consecutive defrostings.	System temperature and/or flow too low. Insufficient available system volume. Significant wind effect.
229 (4)	237	Short run times for compressor	Operation is stopped from the indoor section after less than 5 minutes.	Poor flow, poor heat transfer. Incorrect settings for heating and/or hot water.
230 (78)	238	Hot gas alarm	3 repeated alarms for high discharge within 4 hours.	Disruption in the refrigerant circuit. Lack of refrigerant.
232 (76)	240	Low evaporation temp	5 repeated alarms for low evaporation temperature within 4 hours.	Lack of refrigerant. Blocked expansion valve. Significant wind effect.
264 (203)	254	Communication fault to Inverter	Alarm 203 from heat pump for 20 seconds.	Poor connection between PCB and inverter. Inverter unpowered or broken.
298 (92)	494	Fault in inverter. Heating not working.	The inverter has tried to heat up the compressor, but has failed.	Defective inverter. Discharge sensor (BT14) has come loose from its mount.
300 (94)	495	Sensor BT14 or BP9 loose or defective	Sensor BT14 or BP9 has come loose or is otherwise defective.	The discharge sensor, BT14, or high pressure sensor, BP9, has come loose and is not giving correct measurement values.
341 (6)	291	Recurring safety defr.	10 repeated defrostings according to the protection conditions.	Poor airflow, e.g. because of leaves, snow or ice. Lack of refrigerant.
344 (72)	294	Recurring low pressure	5 repeated low pressure alarm within 4 hours.	Lack of refrigerant. Blocked expansion valve. Disruption in the refrigerant circuit.
346 (74)	295	Recurring high pressure	5 repeated high pressure alarm within 4 hours.	Clogged particle filter, air or stoppage in the heating medium flow. Poor system pressure.
400 (207)	314	Unspecified faults	Initiation fault, inverter.	The inverter is not compatible
400 (209)			The inverter is not compatible	
400 (211)			Configuration file missing.	
400 (213)			Charge error configuration.	

Alarms VVM/SMO (S2125)	Alarms S-series	Alarm text on the display	Description existing alarm	May be due to
425 (108)	322	Persistent pressure switch or over-temperature alarm.	2 repeated LP/HP/FQ alarms within 2.5 hours.	Poor heating medium flow. Lack of refrigerant. For FQ14, the following applies: High temperature 120 °C compressor peak.
427 (110)	323	Safety stop, inverter	Temporary fault in inverter, 2 times within 60 minutes.	Disruption in supply voltage.
429 (112)	324	Safety stop, inverter	Temporary fault in inverter, 3 times within 2 hours.	Disruption in supply voltage.
437 (120)	328	Mains disturbance	Temporary fault in inverter, 3 times within 2 hours or continuously for 1 hour.	Disruption in supply voltage. Incorrect connection in the inverter's terminal block X1.
439 (122)	329	Overheated inverter	The inverter has temporarily reached max working temperature, due to poor cooling 3 times within 2 hours or continuously for 1 hour.	Poor cooling of inverter. Defective inverter.
441 (124)	330	Current too high	Current to inverter too high, 3 times within 2 hours or continuously for 1 hour.	Too high current to inverter. Low supply voltage.
443 (126)	331	Overheated inverter	The inverter has temporarily reached max working temperature, due to poor cooling 3 times within 2 hours or continuously for 1 hour.	Poor cooling of inverter. Defective inverter.
447 (130)	333	Phase failure	Compressor phase is missing, 3 times within 2 hours or continuously for 1 minute.	Disruption in supply voltage. Incorrectly connected compressor cable.
449 (132)	334	Failed compressor starts	Compressor does not start when required, 3 times within 2 hours.	Defective inverter. Defective compressor.
453 (136)	336	High current load, compressor	The output current from the inverter to the compressor has been temporarily too high 3 times within 2 hours or continuously for 1 hour.	Disruption in supply voltage. Poor heating medium flow. Defective compressor.
455 (138)	337	High power load, compressor	The power output from the inverter has been too high 3 times within 2 hours or continuously for 1 hour.	Disruption in supply voltage. Poor heating medium flow. Defective compressor.
501 (184)	353	Failed start, no pressure diff.	The pressure difference between BP9 and BP8 has been too low at compressor start 3 times within 30 minutes.	Fault in pressure sensor BP8, BP9. The compressor does not compress the refrigerant sufficiently. Compressor breakdown.
503 (186)	354	Compressor speed too low	Compressor speed below lowest permitted speed.	The inverter's safety function reduces the speed outside of the compressor's working range.
523	418	Low defrosting flow	The flow is low. Check particle filter and pump.	Clogged particle filter. Defective circulation pump (charge pump). Pressure drop in the heating system is too large.
589 (216)	437	Incorrect PCBA in heat pump. Change to a new PCBA suitable for S2125.	The heat pump has the wrong base board.	The base board has been replaced with a base board for F2120.

Accessories

Detailed information about the accessories and complete accessories list available at www.nibe.co.uk.

Not all accessories are available on all markets.

CONDENSATION WATER PIPE

Condensation water pipe, different lengths.

KVR 11-10

1 metres
Part no. 067 823

KVR 11-30

3 metres
Part no. 067 824

KVR 11-60

6 metres
Part no. 067 825

Technical data

Dimensions

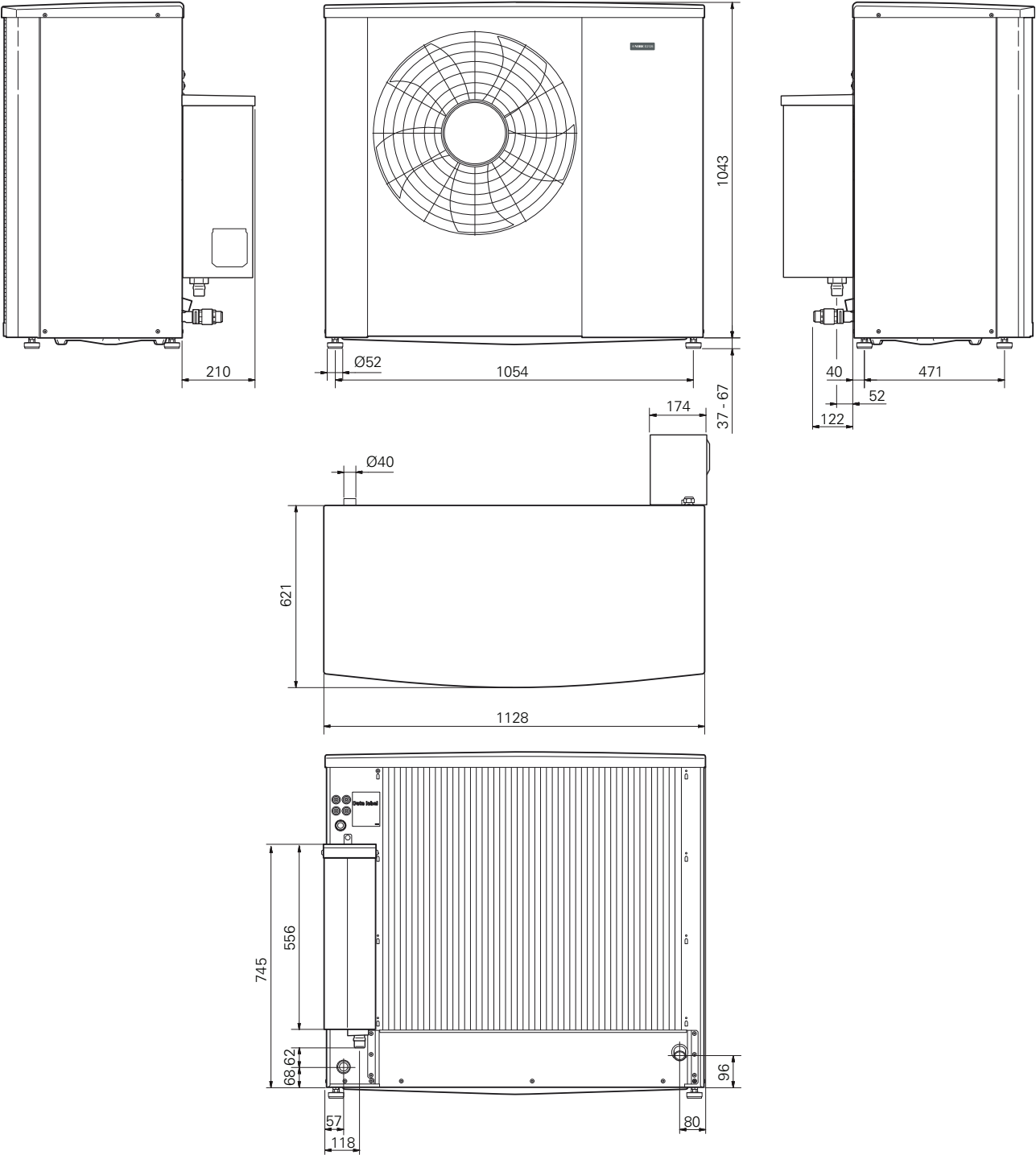

Sound levels

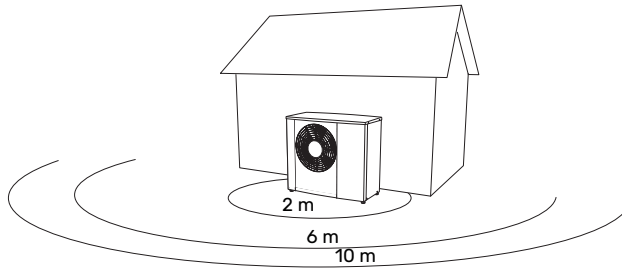

S2125 is usually placed next to a house wall, which gives a directed sound distribution that has to be taken into consideration. Accordingly, when setting up, you should always attempt to select the side that faces the least sound-sensitive neighbouring area.

The sound pressure levels are further affected by walls, bricks, differences in ground level, etc and should therefore only be seen as guide values.

		Sound power ¹	Sound pressure at distance (m) ²									
			1	2	3	4	5	6	7	8	9	10
S2125-8	Nominal sound value	49	44	38	34.5	32	30	28.5	27	26	25	24
	Max. sound value	55	50	44	40.5	38	36	34.5	33	32	31	30
	Max. sound value, silent mode	50	45	39	35.5	33	31	29.5	28	27	26	25
S2125-12	Nominal sound value	49	44	38	34.5	32	30	28.5	27	26	25	24
	Max. sound value	59	54	48	44.5	42	40	38.5	37	36	35	34
	Max. sound value, silent mode	54	49	43	39.5	37	35	33.5	32	31	30	29

¹ Sound power level, $L_w(A)$, according to EN12102

² Sound pressure calculated according to directivity factor $Q=4$

Technical specifications

WORKING RANGE, HEATING

Supply temperature (°C)

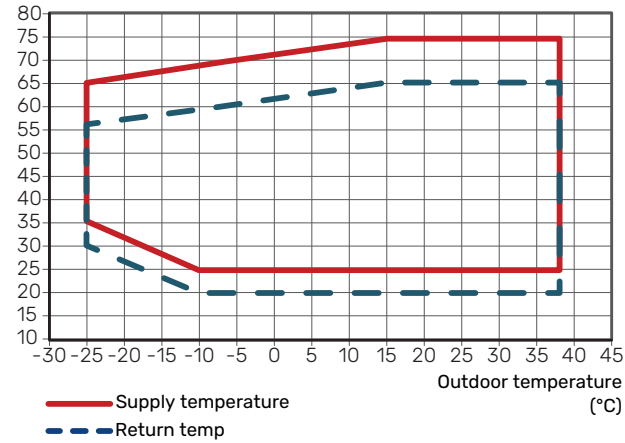

WORKING RANGE, COOLING

Supply temperature (°C)

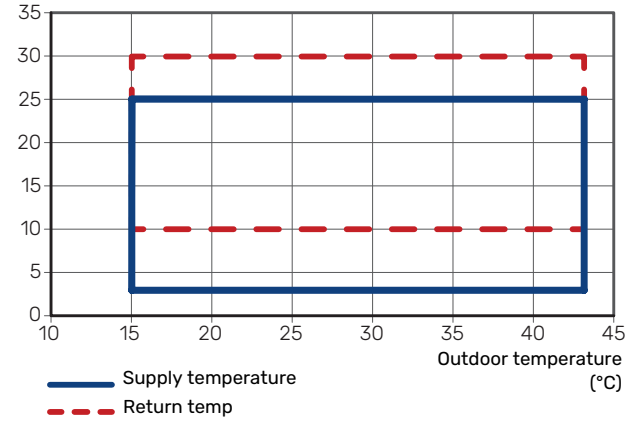

During shorter time it is allowed to have lower working temperatures on the water side, e.g. during start up.

POWER DURING HEATING OPERATION

Maximum and minimum capacity during continuous operation. Defrosting is not included.

S2125-8

Heating output (kW)

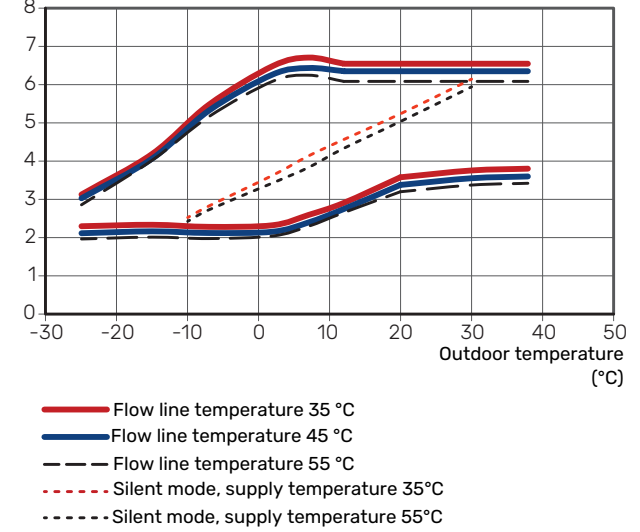

S2125-12

Heating output (kW)

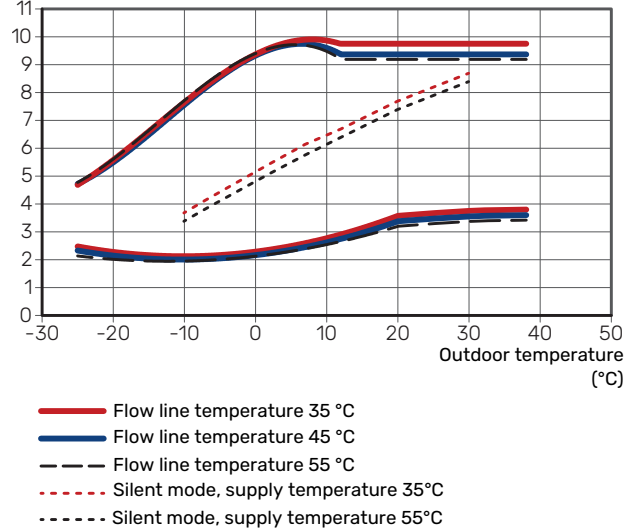

POWER DURING COOLING OPERATION

Maximum and minimum capacity during continuous operation.

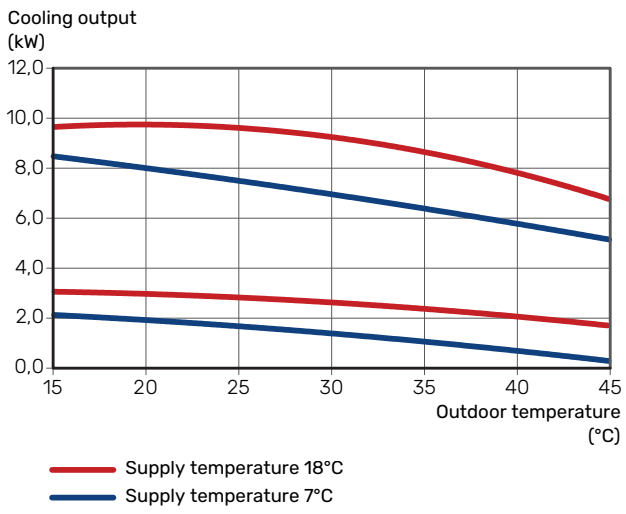

S2125		8	12
Voltage		1 x 230 V	1 x 230 V
Output data according to EN 14 511, partial load¹			
Heating	-7 / 35 °C	4.72 / 1.72 / 2.82	7.23 / 2.73 / 2.65
Capacity / power input / COP (kW/kW/-) at nominal flow	2 / 35 °C	3.20 / 0.72 / 4.44	3.67 / 0.85 / 4.33
Outdoor temp: / Supply temp.	2 / 45 °C	2.95 / 0.87 / 3.39	3.46 / 1.02 / 3.40
	7 / 35 °C	3.15 / 0.69 / 5.18	3.67 / 0.70 / 5.21
	7 / 45 °C	2.97 / 0.76 / 3.90	3.35 / 0.85 / 3.91
Cooling	35 / 7 °C	6.69 / 2.41 / 2.77	6.69 / 2.41 / 2.77
Capacity / power input / EER (kW/kW/-) at maximum flow	35 / 18 °C	8.68 / 2.60 / 3.34	8.68 / 2.60 / 3.34
Outdoor temp: / Supply temp.			
SCOP according to EN 14825			
Nominal heat output (P _{designh}) average climate 35 °C / 55 °C (Europe)	kW	5.33 / 5.30	6.80 / 7.60
Nominal heat output (P _{designh}) cold climate 35 °C / 55 °C	kW	5.40 / 5.20	8.40 / 8.40
Nominal heat output (P _{designh}) warm climate 35 °C / 55 °C	kW	5.50 / 5.20	7.00 / 7.45
SCOP average climate, 35 °C / 55 °C (Europe)		5.00 / 3.70	5.00 / 3.80
SCOP cold climate, 35 °C / 55 °C		4.10 / 3.20	4.20 / 3.40
SCOP warm climate, 35 °C / 55 °C		6.30 / 4.50	6.30 / 4.60
Energy rating, average climate²			
The product's room heating efficiency class 35 °C / 55 °C ³		A+++ / A++	A+++ / A+++
The system's room heating efficiency class 35 °C / 55 °C ⁴		A+++ / A+++	
Electrical data			
Rated voltage		230 V ~ 50 Hz	230 V ~ 50 Hz
Rated current, heat pump	A _{rms}	-	-
Max. power, fan	W	30	50
Fuse	A _{rms}	16	20
Enclosure class		IP24	
Refrigerant circuit			
Type of refrigerant		R290	
GWP refrigerant		3	
Volume	kg	0.8	
Type of compressor		Rotary	
CO ₂ -equivalent (The cooling circuit is hermetically sealed.)	t	0.0024	
Cut-out value pressure switch HP (BP1)	MPa	3.15	
Difference pressostat HP	MPa	2.45	
Cut-out value pressure switch LP (BP2)	MPa	0.03	
Difference pressostat LP	MPa	0.10	
Airflow			
Max airflow	m ³ /h	2,400	2,950
Working area			
Min./max. air temperature, heating	°C	-25 / 38	
Min./max. air temperature, cooling	°C	15 / 43	
Defrosting system		Reverse cycle	
Heating medium circuit			
Max system pressure heating medium	MPa	0.45 (4.5)	
Cut-off pressure, heating medium	MPa	0.25 (2.5)	
Recommended flow interval, heating operation	l/s	0.08 - 0.32	0.12 - 0.48
Min. design flow, defrosting (100% pump speed)	l/s	0.32	
Min./max. HM temp, continuous operation	°C	26 / 75	
Connection heating medium S2125		G1" external thread	
Connection heating medium flex pipe		G1" external thread	
Min. recommended pipe dimension (system)	DN (mm)	25 (28)	
Dimensions and weight			
Width	mm	1,130	
Depth	mm	820	
Height	mm	1,070	
Weight	kg	156	156
Miscellaneous			
Part no.		064 220	064 218

¹ Power statements including defrosting according to EN 14511 at heating medium supply corresponding to DT=5 K at 7 / 45.

² The reported efficiency of the package also takes the controller into account. If an external supplementary boiler or solar heating is added to the package, the overall efficiency of the package should be recalculated.

³ Scale for the product's room heating efficiency class A++ to G. Control module model SMO S

⁴ Scale for the system's room heating efficiency class A+++ to G. Control module model SMO S

Energy labelling

INFORMATION SHEET

Supplier	NIBE		
Model		S2125-8	S2125-12
Temperature application	°C	35 / 55	35 / 55
Seasonal space heating energy efficiency class, average climate		A+++ / A++	A+++ / A+++
Rated heat output ($P_{\text{design,h}}$), average climate	kW	5.3 / 5.3	6.8 / 7.6
Annual energy consumption space heating, average climate	kWh	2,196 / 2,939	2,835 / 4,102
Seasonal space heating energy efficiency, average climate	%	196 / 146	195 / 150
Sound power level L_{WA} indoors	dB	-	-
Rated heat output ($P_{\text{design,h}}$), cold climate	kW	5.4 / 5.2	8.4 / 8.4
Rated heat output ($P_{\text{design,h}}$), warm climate	kW	5.5 / 5.2	7.0 / 7.5
Annual energy consumption space heating, cold climate	kWh	3,238 / 4,055	4,990 / 6,189
Annual energy consumption space heating, warm climate	kWh	1,161 / 1,570	1,494 / 2,180
Seasonal space heating energy efficiency, cold climate	%	161 / 123	163 / 131
Seasonal space heating energy efficiency, warm climate	%	250 / 174	247 / 180
Sound power level L_{WA} outdoors	dB	49	49

DATA FOR ENERGY EFFICIENCY OF THE PACKAGE

Model		S2125-8	S2125-12
Control module model		SMO S	SMO S
Temperature application	°C	35 / 55	35 / 55
Controller, class		VI	
Controller, contribution to efficiency	%	4.0	
Seasonal space heating energy efficiency of the package, average climate	%	200 / 150	199 / 154
Seasonal space heating energy efficiency class of the package, average climate		A+++ / A+++	A+++ / A+++
Seasonal space heating energy efficiency of the package, cold climate	%	165 / 127	167 / 135
Seasonal space heating energy efficiency of the package, warm climate	%	254 / 178	251 / 184

The reported efficiency of the package also takes the controller into account. If an external supplementary boiler or solar heating is added to the package, the overall efficiency of the package should be recalculated.

TECHNICAL DOCUMENTATION

Model				S2125-8			
Type of heat pump	<input checked="" type="checkbox"/> Air-water <input type="checkbox"/> Exhaust-water <input type="checkbox"/> Brine-water <input type="checkbox"/> Water-water						
Low-temperature heat pump	<input type="checkbox"/> Yes <input checked="" type="checkbox"/> No						
Integrated immersion heater for additional heat	<input type="checkbox"/> Yes <input checked="" type="checkbox"/> No						
Heat pump combination heater	<input type="checkbox"/> Yes <input checked="" type="checkbox"/> No						
Climate	<input checked="" type="checkbox"/> Average <input type="checkbox"/> Cold <input type="checkbox"/> Warm						
Temperature application	<input checked="" type="checkbox"/> Medium (55°C) <input type="checkbox"/> Low (35°C)						
Applied standards	EN14825 / EN14511 / EN12102						
Rated heat output	Prated	5,3	kW	Seasonal space heating energy efficiency	η_s	146	%
Declared capacity for space heating at part load and at outdoor temperature T_j				Declared coefficient of performance for space heating at part load and at outdoor temperature T_j			
$T_j = -7\text{ °C}$	Pdh	4.6	kW	$T_j = -7\text{ °C}$	COPd	2.19	-
$T_j = +2\text{ °C}$	Pdh	2.8	kW	$T_j = +2\text{ °C}$	COPd	3.77	-
$T_j = +7\text{ °C}$	Pdh	2.1	kW	$T_j = +7\text{ °C}$	COPd	4.75	-
$T_j = +12\text{ °C}$	Pdh	2.3	kW	$T_j = +12\text{ °C}$	COPd	5.70	-
$T_j = \text{biv}$	Pdh	4.6	kW	$T_j = \text{biv}$	COPd	2.19	-
$T_j = \text{TOL}$	Pdh	4.8	kW	$T_j = \text{TOL}$	COPd	2.21	-
$T_j = -15\text{ °C}$ (if TOL < -20 °C)	Pdh		kW	$T_j = -15\text{ °C}$ (if TOL < -20 °C)	COPd		-
Bivalent temperature	T_{biv}	-10	°C	Min. outdoor air temperature	TOL	-10	°C
Cycling interval capacity	P _{cy}		kW	Cycling interval efficiency	COP _{cy}		-
Degradation coefficient	Cdh	0.97	-	Max supply temperature	WTOL	65	°C
Power consumption in modes other than active mode				Additional heat			
Off mode	P _{OFF}	0.008	kW	Rated heat output	P _{sup}	0.0	kW
Thermostat-off mode	P _{TO}	0.013	kW				
Standby mode	P _{SB}	0.011	kW	Type of energy input	Electric		
Crankcase heater mode	P _{CK}	0.005	kW				
<i>Other items</i>							
Capacity control	Variable			Rated airflow (air-water)		2,400	m ³ /h
Sound power level, indoors/outdoors	L _{WA}	- / 49	dB	Nominal heating medium flow			m ³ /h
Annual energy consumption	Q _{HE}	2,939	kWh	Brine flow brine-water or water-water heat pumps			m ³ /h
Contact information	NIBE Energy Systems - Box 14 - Hannabadsvägen 5 - 285 21 Markaryd - Sweden						

Model		S2125-12							
Type of heat pump	<input checked="" type="checkbox"/> Air-water <input type="checkbox"/> Exhaust-water <input type="checkbox"/> Brine-water <input type="checkbox"/> Water-water								
Low-temperature heat pump	<input type="checkbox"/> Yes <input checked="" type="checkbox"/> No								
Integrated immersion heater for additional heat	<input type="checkbox"/> Yes <input checked="" type="checkbox"/> No								
Heat pump combination heater	<input type="checkbox"/> Yes <input checked="" type="checkbox"/> No								
Climate	<input checked="" type="checkbox"/> Average <input type="checkbox"/> Cold <input type="checkbox"/> Warm								
Temperature application	<input checked="" type="checkbox"/> Medium (55°C) <input type="checkbox"/> Low (35°C)								
Applied standards	EN14825 / EN14511 / EN12102								
Rated heat output	Prated	7,6	kW	Seasonal space heating energy efficiency	η_s	150	%		
Declared capacity for space heating at part load and at outdoor temperature T_j				Declared coefficient of performance for space heating at part load and at outdoor temperature T_j					
$T_j = -7\text{ °C}$	Pdh	6.7	kW	$T_j = -7\text{ °C}$	COPd	2.17	-		
$T_j = +2\text{ °C}$	Pdh	4.2	kW	$T_j = +2\text{ °C}$	COPd	3.83	-		
$T_j = +7\text{ °C}$	Pdh	2.7	kW	$T_j = +7\text{ °C}$	COPd	5.12	-		
$T_j = +12\text{ °C}$	Pdh	2.4	kW	$T_j = +12\text{ °C}$	COPd	5.87	-		
$T_j = \text{biv}$	Pdh	7.6	kW	$T_j = \text{biv}$	COPd	2.11	-		
$T_j = \text{TOL}$	Pdh	7.6	kW	$T_j = \text{TOL}$	COPd	2.11	-		
$T_j = -15\text{ °C}$ (if TOL < -20 °C)	Pdh		kW	$T_j = -15\text{ °C}$ (if TOL < -20 °C)	COPd		-		
Bivalent temperature	T_{biv}	-10	°C	Min. outdoor air temperature	TOL	-10	°C		
Cycling interval capacity	P _{cy}		kW	Cycling interval efficiency	COP _{cy}		-		
Degradation coefficient	Cdh	0.97	-	Max supply temperature	WTOL	65	°C		
Power consumption in modes other than active mode				Additional heat					
Off mode	P _{OFF}	0.008	kW	Rated heat output	P _{sup}	0	kW		
Thermostat-off mode	P _{TO}	0.013	kW						
Standby mode	P _{SB}	0.011	kW	Type of energy input	Electric				
Crankcase heater mode	P _{CK}	0.005	kW						
Other items									
Capacity control	Variable			Rated airflow (air-water)		2,900	m ³ /h		
Sound power level, indoors/outdoors	L _{WA}	- / 49	dB	Nominal heating medium flow			m ³ /h		
Annual energy consumption	Q _{HE}	4,102	kWh	Brine flow brine-water or water-water heat pumps			m ³ /h		
Contact information	NIBE Energy Systems – Box 14 – Hannabadsvägen 5 – 285 21 Markaryd – Sweden								

Electrical circuit diagram

1X 230 V

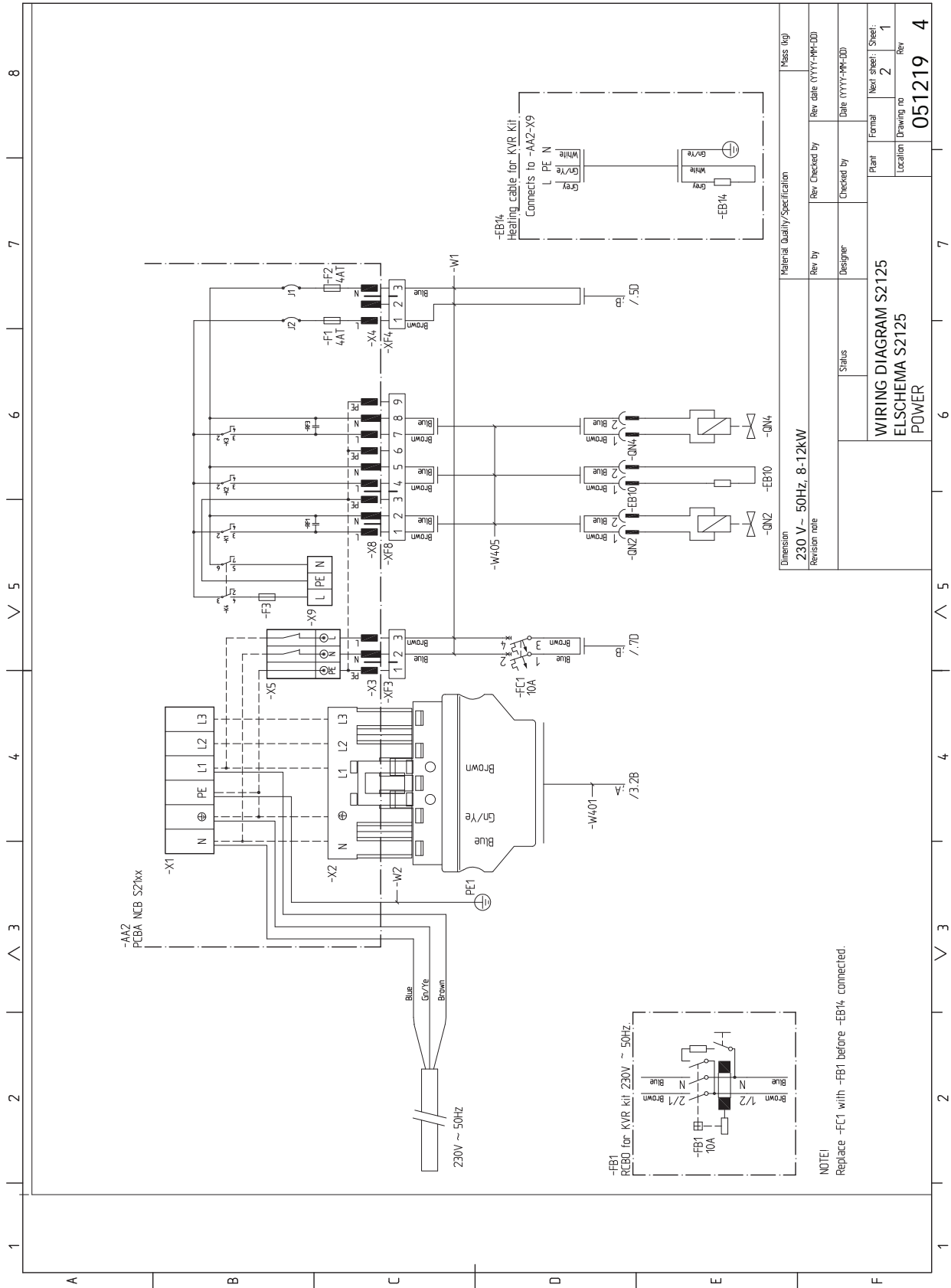

1 2 3 4 5 6 7 8

A B C D E F

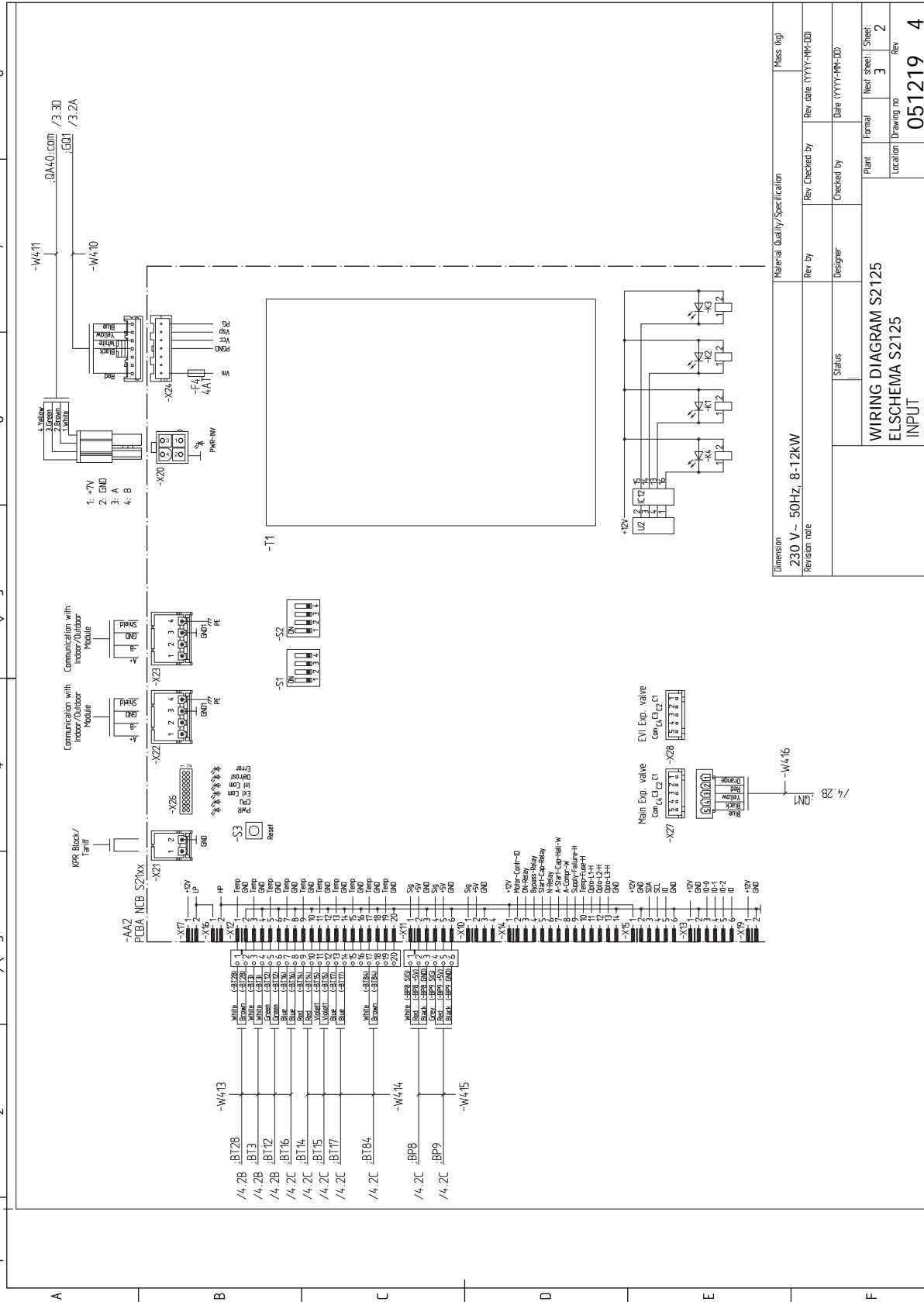

Dimension	Material Quality/Specification	Mass (kg)
230 V ~ 50Hz, 8-12KW		
Revision note	Rev. By	Rev. Checked by
	Designer	Checked by
	Status	Date (YYYY-MM-DD)
	Plant	Formal
	Location	Next sheet: 1 Sheet
		Drawing no
		Rev
		051219
		4

1 2 3 4 5 6 7 8

A B C D E F

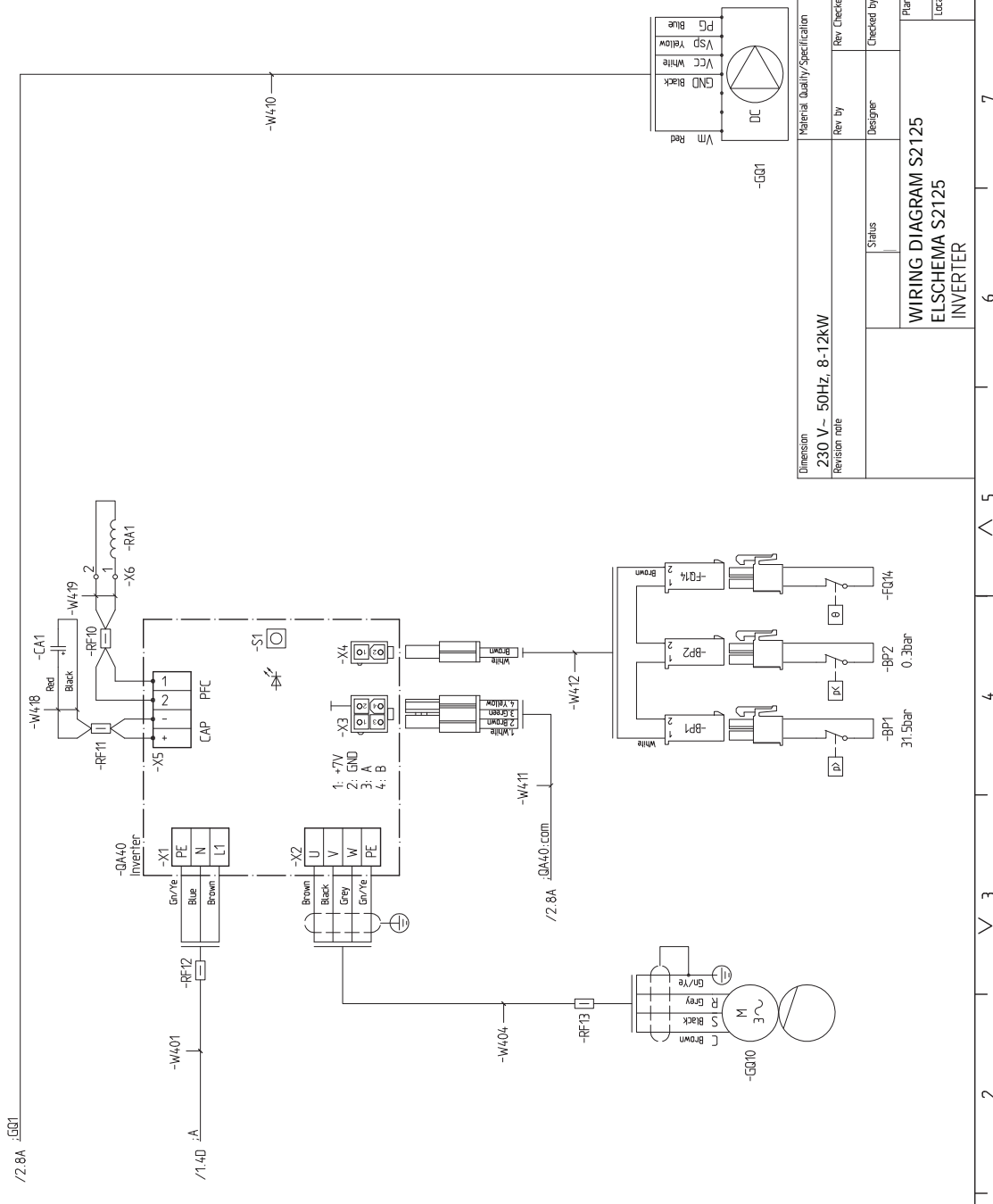

Material Quality/Specification		Mass (kg)	
Vm Red	GND Black	Rev By	Rev date (YYYY-MM-DD)
VSP Yellow	VCC White	Designer	Date (YYYY-MM-DD)
PG Blue		Status	
DC		Plant	Formal
		Location	Drawing no
			Rev
			051219
			4
			3
			4
			3

Dimension: 230 V ~ 50Hz, 8-12kW
 Revision note

WIRING DIAGRAM S2125
 ELSHEMA S2125
 INVERTER

1 2 3 4 5 6 7 8

A B C D E F

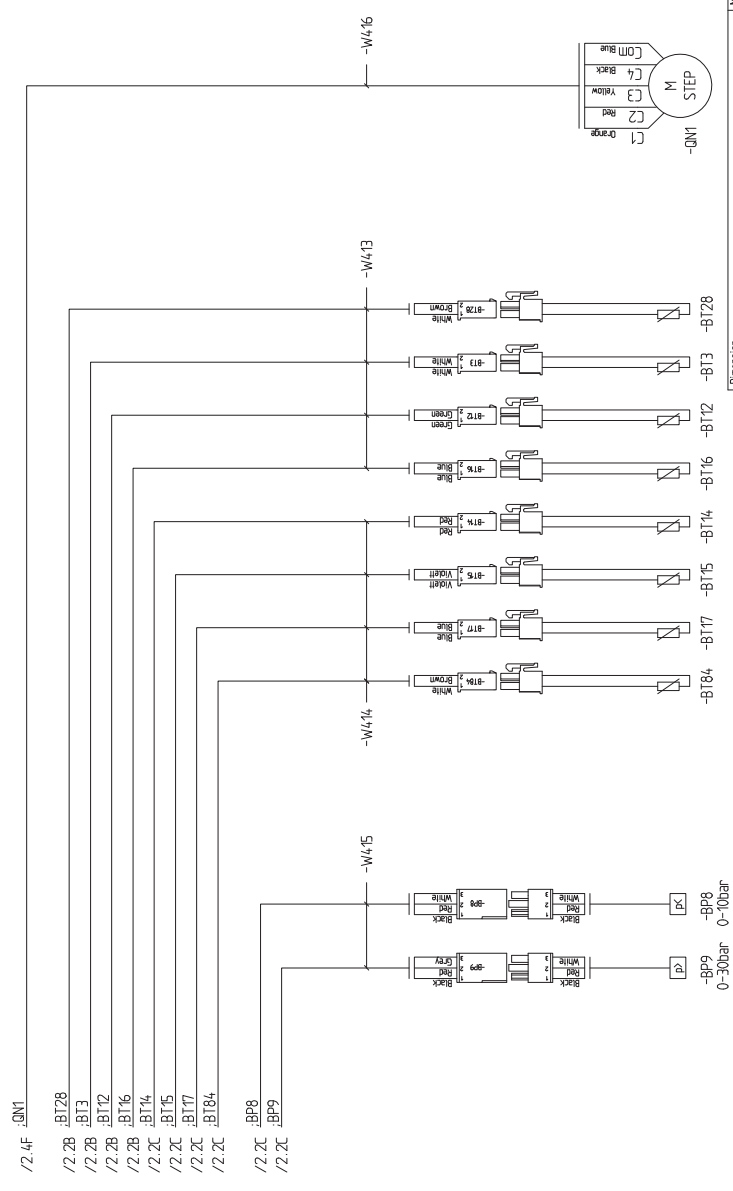

Material Quality/Specification		Mass (kg)	
Rev. by	Rev. Checked by	Rev. date (YYYY-MM-DD)	
Designer	Checked by	Date (YYYY-MM-DD)	
Status	Plant	Formal	Next sheet Sheet
	Location	Drawing no	Rev
WIRING DIAGRAM S2125 ELSCHEMA S2125 SENSORS			051219 4

Item register

- A**
 - Accessories, 44
 - Adjustment, charge flow, 24
 - Alarm list, 42
 - Areas with hard water, 22
 - Assembly, 9
- B**
 - Basic actions, 40
- C**
 - Charge pump, 23
 - Cleaning the climate system, 22
 - Commissioning and adjusting, 31
 - Adjustment, charge flow, 32
 - Filling and venting the heating medium system, 31
 - Post adjustment and bleeding, 31
 - Preparations, 31
 - Start-up and inspection, 31
 - Communication, 28
 - Compatible indoor modules (VVM) and control modules (SMO), 7
 - Component placement
 - Sensor placement, 21
 - Compressor heater, 31
 - Condensation, 11
 - Configuration using DIP switch, 30
 - Connecting accessories, 30
 - Connecting external control voltage, 28
 - Connections, 26
 - Connecting external control voltage, 28
 - Control, 33
 - Control conditions, 34
 - Control conditions, defrosting, 34
 - Control – Heat pump EB101, 35
 - Control – Introduction, 33
 - General, 33
 - LED status, 33
 - Control conditions, 34
 - Control conditions defrosting, 34
 - Control – Heat pump EB101, 35
 - Control – Heat pump EB101
 - Heat pump settings – Menu 7.3.2, 35, 37
 - Control – Introduction, 33
 - Master control, 33
 - Control module, 7
 - Country specific information, 5
- D**
 - Delivery and handling, 8
 - Assembly, 9
 - Compressor heater, 31
 - Condensation, 11
 - Installation area, 10
 - Supplied components, 12
 - Transport, 8
 - Dimensions, 45
 - Disruption to comfort
 - Temperature sensor data, 38
 - Distribution box, 20
 - Disturbances in comfort, 40
 - Alarm list, 42
 - Troubleshooting, 40
 - Draining the heat pump, 38
- E**
 - Electrical circuit diagram, 53
 - Electrical connections, 25
 - Communication, 28
 - Configuration using DIP switch, 30
 - Connecting accessories, 30
 - Connections, 26
 - General, 25
 - Power connection, 26
 - Tariff control, 27
 - Energy labelling, 50
 - Data for energy efficiency of the package, 50
 - Information sheet, 50
 - Technical documentation, 51
- F**
 - Filling and venting the heating medium system, 31
- G**
 - General, 25
- H**
 - Heat pump settings – Menu 7.3.2, 35, 37
 - High room temperature, 40
- I**
 - Ice build-up in the fan, grille and/or fan cone, 40
 - Important information, 4
 - Compatible indoor modules (VVM) and control modules (SMO), 7
 - Control module, 7
 - Country specific information, 5
 - Indoor module, 7
 - Inspection of the installation, 6
 - Safety information, 4
 - Indoor module, 7
 - Inspection of the installation, 6
 - Installation area, 10
 - Installing the installation
 - Symbol key, 23
- L**
 - Large amount of water below S2125, 41
 - LED status, 33
 - Low hot water temperature or no hot water, 40
 - Low room temperature, 40
- M**
 - Marking, 4
 - Master control, 33
- P**
 - Pipe connections, 22
 - Charge pump, 23
 - General, 22
 - Areas with hard water, 22
 - Cleaning the climate system, 22
 - Pipe coupling, heating medium, 23
 - Symbol key, 23
 - Water volumes, 22
 - Pipe coupling, heating medium, 23
 - Post adjustment and bleeding, 31
 - Power connection, 26
 - Preparations, 31
- S**
 - S2125 does not start, 40

- S2125 not communicating, 40
- Safety information, 4
 - Marking, 4
 - Serial number, 4
 - Symbols, 4
 - Warranty information, 5
- Sensor placement, 21
- Serial number, 4
- Service, 38
 - Service actions, 38
- Service actions, 38
- Service measures
 - Draining the heat pump, 38
- Sound levels, 46
- Start-up and inspection, 31
- Supplied components, 12
- Symbol key, 23
- Symbols, 4

T

- Tariff control, 27
- Technical data, 45
 - Dimensions, 45
 - Electrical circuit diagram, 53
 - Sound pressure levels, 46
 - Technical Data, 47
- Technical Data, 47
- Temperature sensor data, 38
- The heat pump design, 17
 - Component locations, 17
 - List of components, 17
- The heat pump's design
 - Distribution box, 20
- Transport, 8
- Troubleshooting, 40
 - Basic actions, 40
 - High room temperature, 40
 - Ice build-up in the fan, grille and/or fan cone, 40
 - Large amount of water below S2125, 41
 - Low hot water temperature or no hot water, 40
 - Low room temperature, 40
 - S2125 does not start, 40
 - S2125 not communicating, 40

W

- Warranty information, 5

Service Record

It is recommended that your heating system is serviced regularly and that the appropriate Service Interval Record is completed.

Service Provider

Before completing the appropriate Service Interval Record below, please ensure you have carried out the service as described in the manufacturer's instructions.

Always use the manufacturer's specified spare part when replacing controls.

Service 1 Date: _____

Engineer Name: _____

Company Name: _____

Telephone No. _____

Operative ID No. _____

Comments: _____

Signature: _____

Service 2 Date: _____

Engineer Name: _____

Company Name: _____

Telephone No. _____

Operative ID No. _____

Comments: _____

Signature: _____

Service 3 Date: _____

Engineer Name: _____

Company Name: _____

Telephone No. _____

Operative ID No. _____

Comments: _____

Signature: _____

Service 4 Date: _____

Engineer Name: _____

Company Name: _____

Telephone No. _____

Operative ID No. _____

Comments: _____

Signature: _____

Service 5 Date: _____

Engineer Name: _____

Company Name: _____

Telephone No. _____

Operative ID No. _____

Comments: _____

Signature: _____

Service 6 Date: _____

Engineer Name: _____

Company Name: _____

Telephone No. _____

Operative ID No. _____

Comments: _____

Signature: _____

Service 7 Date: _____

Engineer Name: _____

Company Name: _____

Telephone No. _____

Operative ID No. _____

Comments: _____

Signature: _____

Service 8 Date: _____

Engineer Name: _____

Company Name: _____

Telephone No. _____

Operative ID No. _____

Comments: _____

Signature: _____

Service 9 Date: _____

Engineer Name: _____

Company Name: _____

Telephone No. _____

Operative ID No. _____

Comments: _____

Signature: _____

Service 10 Date: _____

Engineer Name: _____

Company Name: _____

Telephone No. _____

Operative ID No. _____

Comments: _____

Signature: _____

NIBE Energy Systems Ltd
3C Broom Business Park,
Bridge Way, S41 9QG Chesterfield
Tel: +44 (0)330 311 2201
info@nibe.co.uk
nibe.co.uk

IHB EN 2212-1 631680

This is a publication from NIBE Energy Systems. All product illustrations, facts and data are based on the available information at the time of the publication's approval.

NIBE Energy Systems makes reservations for any factual or printing errors in this publication.

©2022 NIBE ENERGY SYSTEMS

