

DOMESTIC HOT WATER HEAT PUMP

OE03:956-1807



Manual

NIBE™ MT-WH21-019-F

NIBE™ MT-WH21-019-FS

NIBE™ MT-WH21-026-F

NIBE™ MT-WH21-026-FS

TABLE OF CONTENTS

Introduction	4
1. About the product	4
2. Transport, Handling and Delivery	13
3. Positioning	15
4. Water Circuit	17
5. Air system	21
6. Electric Connections	24
7. Control and Operation	25
8. Maintenance	43
9. Disassembly & Decommissioning	46
10. Troubleshooting	48
11. Product and installer information	50

INTRODUCTION

The aim of this manual is to give information, instructions and warnings on the heat pump water heater. The manual is to be used by installers and plumbers as well as by end users, since it contains important safety indications.

The manual is a part of the heat pump water heater and it is to be conserved with care, since it contains important installation and maintenance instructions that can be useful to assure a long life time and an efficient operation.

1. ABOUT THE PRODUCT

The product is a heat pump water heater or also domestic hot water heat pump (DHWHP) that has been designed according to EU directives. The product is intended for hot water production for domestic use or for similar applications. The unit has been designed to be ready for installation.

1.1. Safety precautions

- The product shall be installed, commissioned, repaired only by qualified technicians. Incorrect installation can result in damages of properties and injuries to people and animals.
- The unit shall be disconnected from the power supply when the cover is off.
- The unit shall not be used by children or people with limited physical or mental capacity.
- Children should be supervised to ensure that they do not play with the appliance.
- Cleaning and maintenance shall not be made by children without supervision.
- Do not place flammable materials in contact or close to the unit.
- The water system and the air system should be installed as stated in the manual.
- When in service, the unit should not be placed in subzero temperature areas.
- When not in service, the unit can be placed in subzero temperature areas, but all the water in the tank or in the condensate drain should be removed.
- Hot water can cause serious burns if directly connected to the taps. The installation of a mixing valve is suggested.
- The unit should be used only for its specified use. The manufacturer is not liable for any damages due to failure to observe this manual.
- Take all the possible precautions to avoid incidents.
- The product contains HFC-R134a.

1.2. Technical data

1.2.1. General

The heat pump water heater is composed of a water tank, a refrigerant circuit, a cabinet and a display connected to a control board. The main scope of the appliance is to heat water stored in a tank.

1.2.2. Operation

The unit is programmed to start heating the water inside the tank when its temperature falls below a predetermined level. The unit stops when the water temperature reaches a set point that can be regulated by the user. In general, the appliance is designed to produce enough hot water to cover the need of a household of 4 persons or more.

There are two ways in which the unit can heat the water:

1) Heat pump operation

In the operation with heat pump, a refrigeration cycle utilizes the operation of a compressor and the extraction of heat from the air to heat the water in the tank. This is the standard way used to heat the domestic hot water, since it leads to lower electricity consumption, hence also lower running costs.

More information regarding the heat pump operation and the cooling circuit can be found in paragraph 1.2.3.

2) Electric heater operation

The water is heated using an electric heater. An electric resistance is powered to heat the water in a safe, fast and flexible way. However, using the electric heater can become an expensive way to produce hot water. This operation should be used as a back-up or as integration of the standard operation.

The electric heater is activated in case of:

- Failure of the heat pump operation.
- Too high or too low air temperatures.
- The quantity of hot water produced is not enough.

1.2.3. Cooling circuit

As depicted in Figure 1 and 2, the heat pump cycle can be divided in four main processes: compression (1-2), condensation (2-3), expansion (3-4), evaporation (4-1) described below.

- At the suction of the compressor (1) the superheated gas refrigerant enters the compressor at low pressure.
- In the compressor, the gas is compressed to a higher pressure and temperature level (2).
- The gas is first de-superheated and condensed in the condenser, exchanging heat with water stored in the tank.
- The refrigerant exits the condenser in a subcooled, liquid form (3)
- Through a thermostatic expansion valve the pressure of the refrigerant is lowered to allow its evaporation at lower temperatures (4).
- The refrigerant is evaporated in the fin-coil heat exchanger that uses forced air as heat source (1).
- The process goes on until the power supply to the compressor is stopped.

A deeper description of the cooling circuit and all components used for its design can be found in Figure 3, 4 and 5.

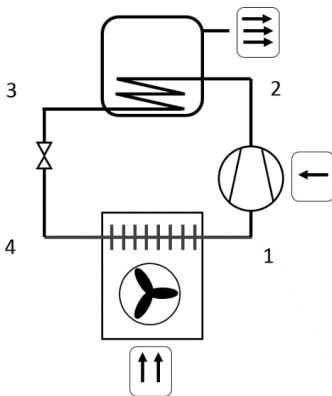

Figure 1 - Heat pump principle

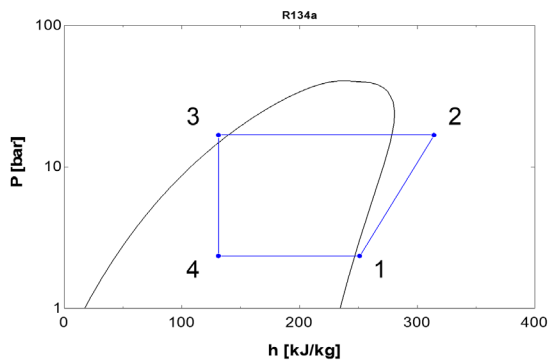

Figure 2 - Pressure-Enthalpy diagram

Note: The extensive use of the electric heater leads to higher electricity consumption and it may lead to high electricity bills. The operation with electric heater normally consumes 3 times more electricity than the operation with heat pump. The energy released to the condenser (2-3) is, in fact, the sum between the free energy extracted from the air in the evaporator (1-4) and the energy supplied to the compressor (2-1). On average, the energy absorbed by the evaporator is more than double of the energy used to run the compressor.

1.2.4. Safety instructions – Cooling circuit

- Only skilled and trained technicians shall carry out repair and service of the heat pump circuit.
- Before opening the cooling circuit, discharge the refrigerant to a level that allows safe working conditions.
- The refrigerant can be toxic if inhaled or if in high concentrations.
- Special attention should be given if the work is carried out with an open flame.

1.2.5. Process and Instrumentation Diagram

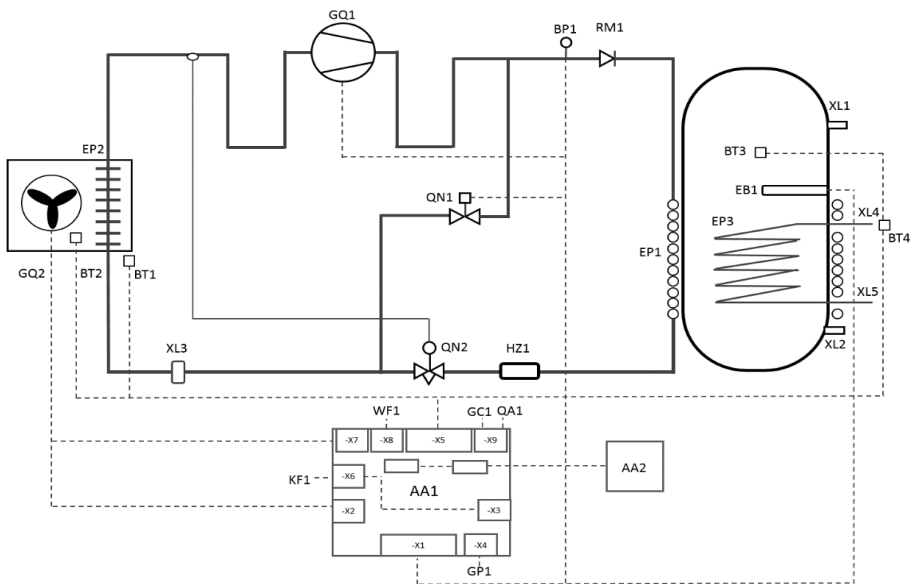

Figure 3 – Process and Instrumentation Diagram

Refrigerant circuit

GQ1: Compressor

GQ2: Fan

RM1: Check valve

EP1: Condenser

EP2: Evaporator

HZ1: Filter drier

QN1: Solenoid valve

QN2: Thermostatic expansion valve

XL3: Service valve

Water circuit

XL1: Water outlet

XL2: Water inlet

XL4*: Coil top

XL5*: Coil bottom

XL6: Air outlet

XL7: Air inlet

XL8: Condensate outlet

XL9*: Hot water circulation

EP3*: Coil

EB1: Electric heater

FR1: Anode

FN1: Thermal protection

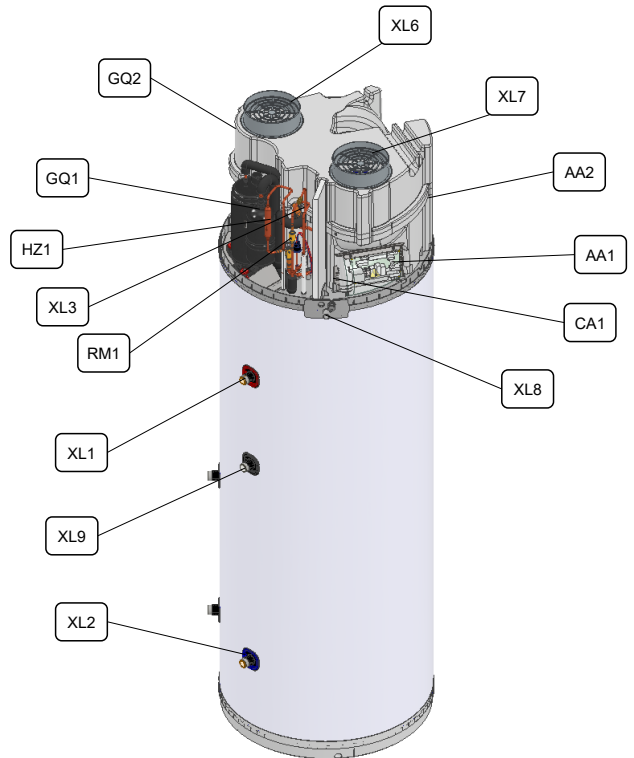

Figure 4 - Design of the cooling circuit and the main components

The items with * are optional.

Sensors

- BT1: Air inlet temperature
- BT2: Evaporator temperature
- BT3: Tank water temperature
- BT4*: Additional temperature
- BT5*: Additional temperature (not included)
- BP1: Pressostat

Electric components

- AA1: Main printed circuit board
- AA2: Display circuit board
- WF1: Modbus port
- GC1*: Solar 0-3V/10V
- QA1*: SG-ready port
- GP1*: Additional supply to pump or damper
- KF1*: Wi-Fi

The items with * are optional.

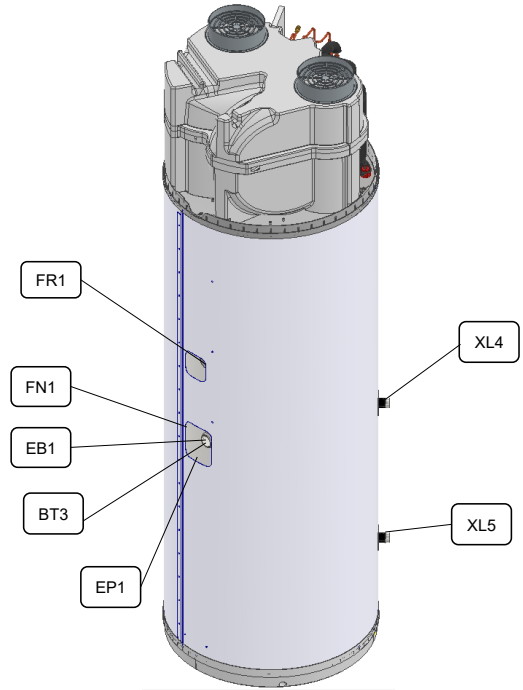

Figure 5 - Design of tank, condenser and related components

Nomenclature according to standard IEC 81346-1 and 81346-2.

1.2.6. Main Technical Data

The main technical data are collected in the following figures and table.

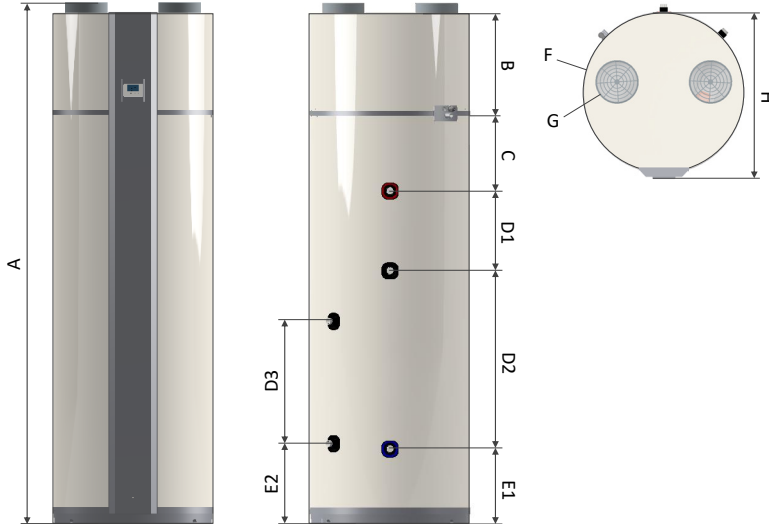

Figure 6 - Dimensional data

Parameter	Unit	190L	260L
Dimensional data			
A - Height	mm	1610	1960
B	mm	385	385
C	mm	280	280
D1	mm	180	300
D2	mm	435	670
D3	mm	375	460
E1	mm	285	285
E2	mm	305	305
F - Diameter	mm	603	603
G - Diameter	mm	160	160
H - Max diameter	mm	620	620
Height required for installation	mm	1700	2040
Weight dry/wet (with coil)	kg	94/284 (100/300)	100/350 (120/370)
Nominal insulation thickness	mm	50	50

Parameter	Unit	190L	260L
Electrical data			
Power supply	V/Hz	230/50	
Fuse	A	13 (10)	
Electric connections	-	L1, N, G	
Electric heater power	W	1500	

Cooling and water circuit

Refrigerant type	-	R134a	
Refrigerant quantity	g	1200	1280
GWP	-	1430	
CO2 equivalent	ton	1.7	1.8
Cooling circuit	-	Hermetically sealed	
Protection rating	-	IP21	
Water connections - Enameled	in	¾ - BSPT (ISO 7-1)	
Water connections - Stainless*	mm	22 - Compression fittings	
Water condensate connection	mm	Ø19	
Nominal insulation thickness	mm	50	50
Corrosion protection	-	Magnesium anode / Stainless steel	

Performance data

Outdoor air at 7°C (EN16147)			
COP	-	3.57	3.69
Heat up time	hh:mm	06:28	09:12
Stand-by heat losses	W	17	20
Sound power	dB(A)	49	49
Indoor air at 20°C (EN16147)			
COP	-	4.34*	4.20
Heat up time	hh:mm	05:15*	07:09
Stand-by heat losses	W	17*	21
Sound power	dB(A)	55.6	55.6
Volume at 40°C	L	247	347
Auxiliary power	W	1.61	1.61

*To be subjected to 3rd party test.

Parameter	Unit	190L	260L
Airflow			
Nominal air flow rate (variable range)	m ³ /h	450 (0-800)	
Maximum fan power consumption	W	85	
Max external static pressure	Pa	200	
G - Air duct connections	mm	160	
Minimum volume of room installation	m ³	30	
Operating limits			
Max air temperature	°C	40	
Min air temperature	°C	-7	
Max water temperature	°C	60	
Max water pressure	MPa	0.6 or 1.0. Check nameplate	

Art. no.

Art no 019-F/026-F	084109	084111
EPREL no. 019-F/026-F	2105503	2105506
Art no 019-FS/026-FS	084110	084112
EPREL no. 019-FS/026-FS	2105504	2105509

1.2.7. Fan Curve

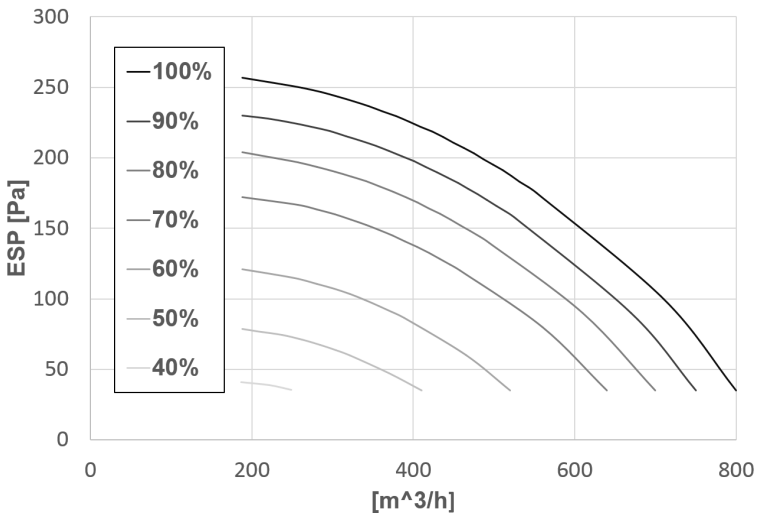

Figure 7 - External static pressure vs airflow at different fan speeds.

In order to assure an efficient operation, it is suggested to keep the external pressure drops below 200 Pa.

2. TRANSPORT, HANDLING AND DELIVERY

Immediately upon receipt, the domestic hot water heater pump must be examined to make sure that it is intact and undamaged. If not, the shipping company must be informed immediately. The recipient has the responsibility for all the shipments unless otherwise agreed.

2.1. Delivery Mode

The appliance is delivered without condensate drain tube and the safety equipment for the water circuit.

2.2. Storage

The unit must be stored and preferably transported upright, free of water and within its packaging.

Transport and storage may take place at temperatures between -10 °C and +50 °C. If the unit has been transported or stored at sub-zero temperatures the unit should be left at room temperatures for 24 hours before commissioning.

2.3. Transport with Forklift

For transport with a forklift, the unit must stand on the associated transport frame. Always lift the unit slowly. Due to the high center of gravity, the appliance must be secured against tipping during transportation.

2.4. Unloading the Heat Pump

In order to avoid damages, the unit must be unloaded on a flat surface.

2.5. Transport with Trailer

The unit must only be transported on the associated transport frame. This also applies to transport on stairs.

The unit must be secured against sliding on the trailer.

Water connections etc. shall not be used for transportation purposes.

It should be made sure that the trailer does not damage the cabinet or the various connections.



Figure 8 - Transport with trailer

2.6 Horizontal transport

When carefully transporting the unit over a short distance to its final location, the unit can be transported horizontally in its packaging on the dedicated side. If the unit has been tilted more than 45°, the unit must be left in its normal upright position for at least 24 hours before it is started.

3. POSITIONING

The installation site should be equipped with a power supply of 220-240V and 50 Hz. The power supply and the hydraulic system must comply with the local regulations.

The unit should be placed vertically, with a maximum inclination of 1°. The unit must be well balanced and stable on the ground surface. Use the built-in adjustable pads to level the unit.

The unit must be installed as close as possible to the hydraulic system in order to minimize heat losses in the water pipes. The water pipe outlet should be insulated for the same reason.

The unit should not be placed in direct contact with the sunlight.

The unit can only be installed in a frost-free room and it should follow the criteria:

- Room temperature between 5°C and 40°C.
- Drain possibility for condensate and floor drain.
- No abnormal dust concentration in the air.
- Solid base (approx. 500 kg / m²).
- It is necessary to ensure that there is sufficient space around the unit for maintenance and service. A clearance of 0.5 m around the unit is recommended.

Ducted unit

In case of a ducted unit, the unit should be installed as close as possible to the walls in order to minimize pressure losses in the air ducts.

Not-ducted unit

In case the unit is used without exhaust/extraction air ducts, it should be placed in a room with the following characteristics:

- The volume of the room should be more than 30 m³.
- The room should be well ventilated.
- There should be no other appliances that need air to operate.
- The minimum distances described in Figure 9 should be respected.

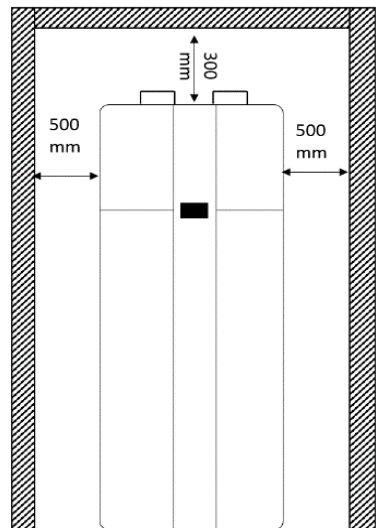

Figure 9 - Minimum distance from walls for not-ducted units

3.1. Set-up sequence

Once the unit is placed in a room with characteristics as specified in the previous paragraph, then it can be prepared following the sequence described below:

1. Remove the packaging from the pallet.
2. Remove the transport fittings from the pallet.
3. Remove the unit off the pallet and place it on the floor.
4. Adjust the unit vertically by adjusting the feet.
5. Check that the unit has no damages.
6. Set-up the water circuit (See chapter 4) and fill the tank with water.
7. Set-up the air circuit (See chapter 5).
8. Set-up the electric connections (See chapter 6).

When the unit is supplied with electricity, it automatically starts running in its standard operation according to the factory settings as described in Chapter 7.

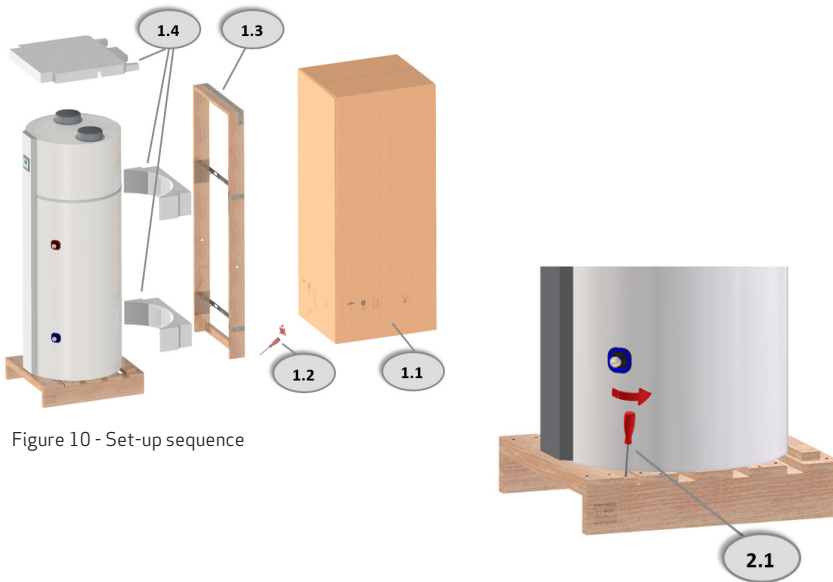

Figure 10 - Set-up sequence

4. WATER CIRCUIT

The water circuit must be installed in accordance with local norms and standards. The water used must be drinking water.

Material compatibility in the whole system must be ensured. Incorrect material combinations in the water circuit can lead to damage due to galvanic corrosion. This requires special attention when using galvanized components and components that contain copper.

The pipe sizes for on-site installation shall be based on the available water pressure as well as the expected pressure loss in the pipe system.

As for all pressurized vessels, the heat pump water tank has to have an approved safety valve (pressure setting depending on local rules and regulations) and a non return/check valve on the cold water inlet.

The following figure depicts the suggested configuration on the water system, with the possibility to include a water recirculation circuit. This last connection is optional.

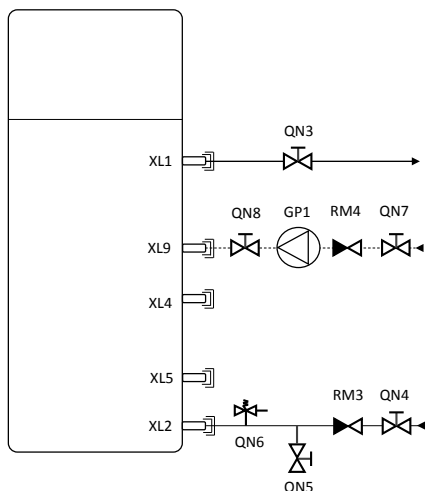

- XL1: Water outlet pipe connection
- XL2: Water inlet pipe connection
- XL4*: Coil top
- XL5*: Coil bottom
- XL9*: Water circulation connection
- QN3: Shut-off valve water outlet
- QN4: Shut-off valve water inlet
- QN5: Drain valve
- QN6: Safety valve
- QN7: Shut-off valve pump inlet
- QN8: Shut-off valve pump outlet
- RM3: Check valve
- RM4: Check valve water circulation
- GP1: Water circulation pump

Figure 11 - Diagram of suggested water circuit connections

4.1. Water connections

Dirt in the pipe work must be avoided. After installation of the external pipes flush if required before connection of the domestic hot water heat pump.

If no circulation of water is needed, make sure that the circulation connection is properly sealed.

When installing the pipes please ensure that the pipe connections are not excessively stressed. Use a pipe wrench to relax torque forces on the pipe connections.

The water pipe outlet should be insulated to reduce heat losses to the ambient and to reduce the risk of injuries and burns.

4.2. Location of connecting pipes

Hot water outlet pipe is mounted on the upper connecting branch.

If the unit is equipped with the hot water circulation access, the middle connecting branch is used for hot water return. Inlet of fresh cold water is mounted on the bottom connecting branch.

4.3. Connection of condensate drain

While the heat pump is running, condensate will form, which is to be discharged to the sewage drain via the condensate drain pipe, Ø 19 mm connection outside. The quantity of condensate depends on the humidity, the air flow, and the temperature of the air.

The condensate connecting branch must be equipped with an air tight water trap and run to a drain. The water trap must contain a standing water column of at least 60 mm.

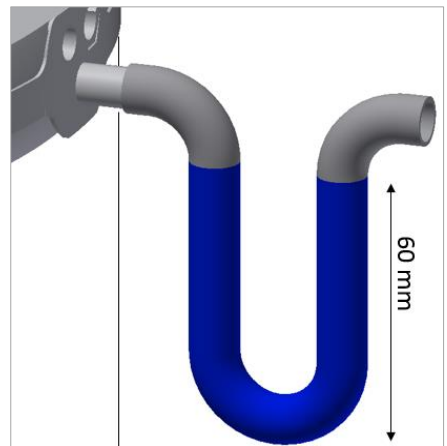

Figure 12 - Condensate drain

Neglecting to install a drain trap can lead to damage to the appliance. If the drain trap is not installed correctly, the product warranty is not valid.

4.4. S Coil connection (optional)

In the unit there can be an extra heat exchanger installed. In the sensor pocket for the thermostat sensor, there can also be placed a sensor to control the external connection e.g. oil burner, wood burner etc. The maximum inlet temperature of the heating coil is 90 °C. If there is risk of inlet temperatures above 90 °C the installer must install an external device preventing high inlet temperature to the heating coil.

4.5. Safety instructions - Water circuit

- Only drinking water must be used.
- During installation, attention must be paid to the choice of materials and it must be ensured that chosen materials work together without problems in the entire circuit.
- Special attention must be paid when using galvanized components and components containing aluminum.
- Safety equipment must be installed to prevent over pressure in the system. Always use a safety valve with maximum relief pressure according to the unit nameplate and a stop valve (approved according to heating and plumbing regulations). All pipe work has to be installed according to plumbing and heating regulations.
- The discharge pipe of the pressure-relief device (safety valve) must be installed frost free and with a slope away from the device. The pipe must also be left open to the atmosphere.
- Temperatures above 90 °C in the heating coil may cause excessive pressures in the cooling circuit.

4.6. Leak test

After installation it is necessary to check that the entire water installation is tight. This is accomplished by performing a water leak test.

4.7. Commissioning of the water circuit

Fill the water tank via the cold water connecting branch. Deaerate the water tank by opening one of the hot water taps located at the highest level until air no longer appears at the tapping point.

A few days after the initial setup and start-up, check the installation for leaks in the water installation or blockage of the condensate drain.

5. AIR SYSTEM

The inlet air must not be polluted with aggressive components (ammonia, chlorine etc.) as components parts of the heat pump unit may be damaged. The air also needs to be free of dust and other particles.

Inlet and outlet ducts shall be made of rigid smooth pipes to minimize pressure losses. Please take into account the fan working pressure and the ducts pressure losses during dimensioning of the duct system (see technical data).

The two connections to the heat pump are \varnothing 160 mm. It is advised to install the air ducts near the heat pump, levelled or with a slight inlet, in order to avoid ingress of condensed water from the duct system to the heat pump.

All air ducts should be insulated after they have been installed, in order to reduce heat loss and noise level. Insulation has to be applied to protect against external condensation on the cold exhaust duct.

It is recommended to mount a flexible connection between the air duct and duct connection to ease future service of the unit.

It is also recommended to install silencer units in between the heat pump unit and the ventilation system to avoid potential travel of noise from the unit to the ventilation system.

The unit has been designed to operate with different air ducts configurations:

- 1) **Not-ducted unit, ambient air.** The unit extracts heat from the ambient air and lowers the air temperature of 5-15 °C according to the operating conditions. Since the air is re-directed to the room, this configuration is particularly interesting during summer periods. This configuration is not suggested for winter periods, especially if the room in which the appliance is located is heated by other appliances.
- 2) **Partially ducted unit, ambient air.** This configuration is normally preferred to configuration 1 since the cold air coming out from the unit is directed out of the house.
- 3) **Ducted unit, external air.** This configuration minimizes the temperature decrease of the installation site, since there is no contact between the air in the room and the air through the heat pump. It is suggested to place the inlet pipe

far from and possibly higher than the outlet pipe, to minimize the recirculation of cold air into the unit.

- 4) **Ducted unit, exhaust air.** This is the configuration that normally minimizes the electricity consumption of the unit. It is particularly suggested if there is no cooling demand in the installation site.

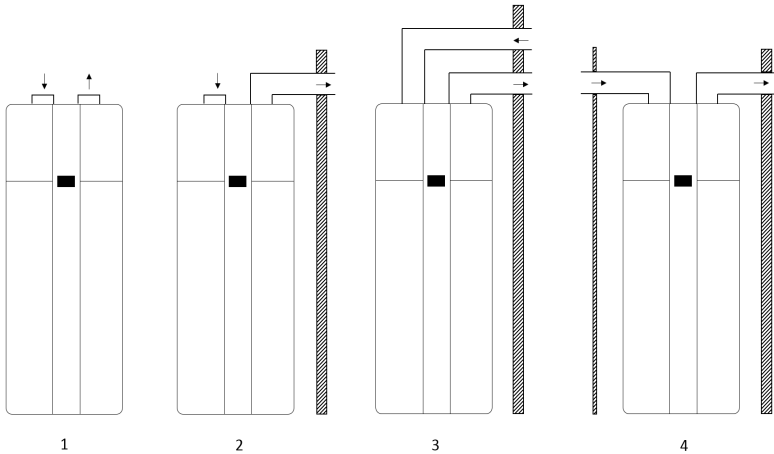

Figure 13 - Air ducts configuration

The appliance is normally supplied with two air duct connections with a plastic net with a protective function (Figure 14).

If the appliance is used as ducted unit it is highly suggested to manually remove the plastic net by using a set of pliers. This operation allows the unit to run more efficiently, since the air pressure losses in the air circuits are minimized.

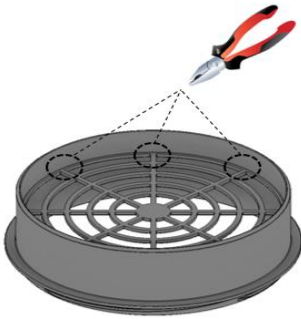

Figure 14 - Standard connection for use with ambient air, not ducted units.

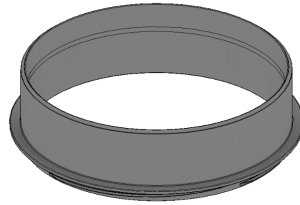

Figure 15 - Connection for use with ducted units.

6. ELECTRIC CONNECTIONS

The unit must be supplied with current at 220-240V and 50 Hz.

The unit is supplied with a standard Schuko plug. If local regulations dictates fixed installation or if the supplied plug does not ensure correct earthing, cut off the Schuko plug from the power supply cable.

When the unit is connected to the power supply, it will turn on automatically and it will start its operation automatically.

- The first time that the unit is turned on, it will start its operation according to its factory settings.
- If some control settings are modified, the unit will start with the same settings at the previous switch off conditions.

6.1. Electric Diagram

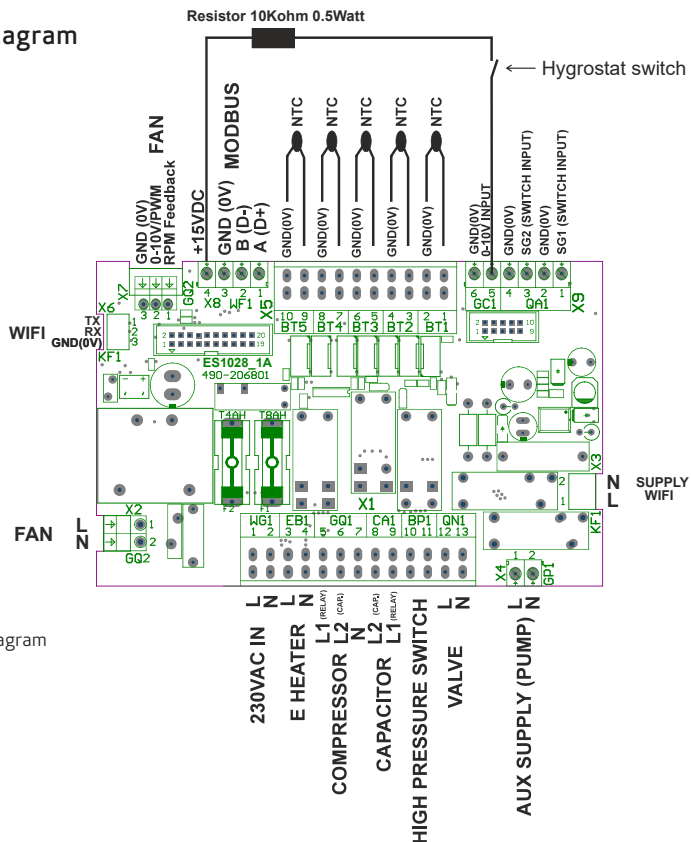

Figure 16 - Wiring diagram

7. CONTROL AND OPERATION

7.1. Home view

The unit can be controlled from the control panel described in Figure 17. From the home view, all the main operational modes, functions, set points and information on the unit can be accessed.

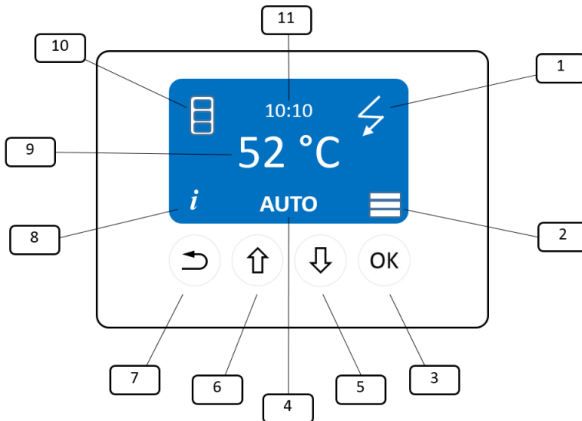





Figure 17 - Display, control panel

- 1: Electric heating state (ON/OFF)
- 2: Main menu (Can be open by pressing **OK**)
- 3: OK/Enter
- 4: Mode (Change with  or )
- 5: Scroll down
- 6: Scroll up
- 7: Return back
- 8: Information (open with )
- 9: Temperature set point
- 10: Heat pump operation (Heat pump, Ventilation, Defrosting)
- 11: Time

The top part of the screen gives information about the unit operation, time and temperature set point. This part is passive and it is changed automatically.

The bottom part of the screen is active, meaning that the icon on the screen contains other menu items. This part is divided in three menus:

- INFORMATION MENU (8), that can be accessed by pressing (↩)
- MODE MENU (4), that can be accessed by pressing (↑) or (↓)
- MAIN MENU (2), that can be accessed by pressing (OK)

The MAIN MENU is composed of 4 sub menus:

- Temperatures
- Functions
- General
- Installer

The menu items with * are optional functions.

7.2. Information menu

The information menu can be opened pressing button (↩) from the home view. This menu gives all the operational information of the unit. The available information are divided in four groups:

- Temperatures (T)
- Collected data on the unit operation and performance (I)
- The state of the relays of the unit (R)
- The errors and alarms of the unit (Er)

All the information that can be shown in the information menu are described in the following table. All temperatures are in °C.

Class	Code	Menu Item	Description
T	T1	T air i	The air temperature at the inlet of the unit
	T2	T air o	The evaporator temperature at the outlet of the unit
	T3	T water t	The water temperature at the top of the unit
	T4	T water b*	The water temperature at the bottom of the unit
	T5	T extra*	The temperature measured by the additional sensor
V	V1	Fan %	The actual speed of the fan in %.
	V2	Input V*	The actual input signal in GC1 (0-10V) from the PV or hygrostat in Volts.
I	I1	HP hr	The total amount of hours that the compressor has been running
	I2	EL hr	The total amount of hours that the electric heater has been running
	I3	Fan hr	The total amount of hours that the fan has been running
	I4	T Avg a	The average air temperature with operating unit is displayed in °C since last Reset All
	I5	T Avg e	The average evaporator temperature with operating unit in °C since last Reset All
	I6	HP ON	The number of START/STOPS for the entire unit life time since last Reset All
	I7	W el	The calculated instantaneous electricity consumption in W since last Reset All
	I8	MWh el	The total calculated electricity consumption in MWh since last Reset All
	I9	W th	The calculated instantaneous heating capacity is displayed in W
	I10	MWh th	The total calculated hot water production is displayed in MWh since last Reset All
	I11	EL MWh	The electricity consumption of the electric resistance in MWh since last Reset All
R	R1	Extra*	The operation of the extra relay, for example for the operation of a circulation pump
	R2	Defrost	The operation of the relay that controls the solenoid valve for the defrosting function is shown
	R3	Fan	The fan speed is shown in %
	R4	HP	The operation of the compressor is shown
	R5	EL	The electric heater operation is shown

Class	Code	Menu Item	Description
Er	Er1	T1 Error	The temperature sensor T1 is out of range
	Er2	T2 Error	The temperature sensor T2 is out of range
	Er3	T3 Error	The temperature sensor T3 is out of range. If T3 Error occurs, the unit does not heat the water in any way
	Er4	T4 Error*	The temperature sensor T4 is out of range. The error Er4 is ignored and the unit runs normally
	Er5	T5 Error*	The temperature sensor T5 is out of range. The error Er5 is ignored and the unit runs normally
	Er6	Err HP	The pressure switch opens, when the pressure in the cooling circuit is above the limit of pressure specified on the high pressure switch
	Er7	Err Evap	The temperature sensor T2 is above T1 - 2°C for more than one hour
	Er8	Err C Evap	The temperature T2 is below - 25°C
	Er9	Err H Evap	The temperature T2 is above D11 (Evaporator T max)
	Er10	Filter	Replace filter. The alarm is displayed on the main screen, but the operation of the unit is not affected.

7.3. Mode of operation

Different strategies to heat the water can be selected from the main control panel pressing 5 or 6 (Scroll down or scroll up) from the home view.

The possible modes of operation to choose from are found in the following table:

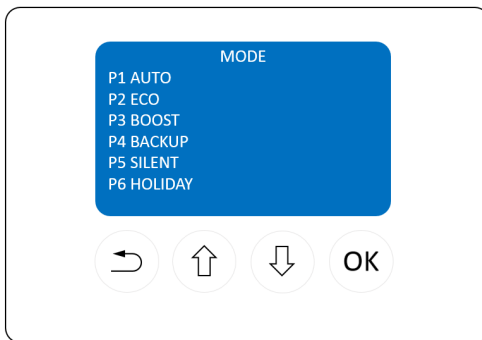

Figure 18 - Modes of operation

Code	Set point name	Description
P1	AUTO	The heat pump heats the water when required, normally using the heat pump operation. The unit starts when the water temperature T3 is more than 5°C below A1 (T AUTO) and it stops when this temperature is reached. If the air temperature is out of the feasible limits, the water is heated with the electric heater.
P2	ECO	The heat pump consumes as low energy as possible. The heat pump has a lower water temperature set point A2 (T ECO). The heat pump heats the water to a lower temperature compared to the other operations.
P3	BOOST	The heat pump and the electrical heater operate simultaneously when possible. The unit starts when the water temperature T3 is more than 5 °C below A3 (T BOOST) and it stops when this temperature is reached. If A3 (T BOOST) is higher than D33 (T HP max) the compressor stops when the temperature D33 (T HP max) is reached. The remaining temperature lift is accomplished with only the electric heater.
P4	BACKUP	This is an emergency mode. When an error occur, preventing the operation of the heat pump, the water cannot be heated. On the display the possibility to activate the BACKUP mode is asked to the user. In BACKUP mode the water is heated up by the electric heater at a lower temperature than the desired one. The Legionella control is active in any case. The unit starts when the water temperature T3 is more than 5 °C below D12 (BACKUP T) and it stops when this temperature is reached.
P5	SILENT	The fan speed decreases to the minimum in order to minimize the sound emission of the unit in operation. The unit starts when the water temperature T3 is more than 5 °C below T1 (T AUTO) and it stops when this temperature is reached.
P6	HOLIDAY	The heat pump is turned off and only the LCD display is active. The heat pump does not start when water heating is required. The compressor is OFF except during LEGIONELLA control in which it can be activated. The HOLIDAY mode is connected to the Hot on time function B4 (Hot on time). After the HOLIDAY period is completed, the unit goes back to the previous mode of operation.

Note: the unit can be turned off switching to HOLIDAY mode.

7.4. Main Menu

Entering this menu requires a good understanding of the unit operation.

It is highly recommended to read and well understand the descriptions of the following menu items. Changing some of these set points can have large effects on how the appliance operate and performs.

The main menu is divided in four sections:

- Temperatures
- Functions
- General
- Installer

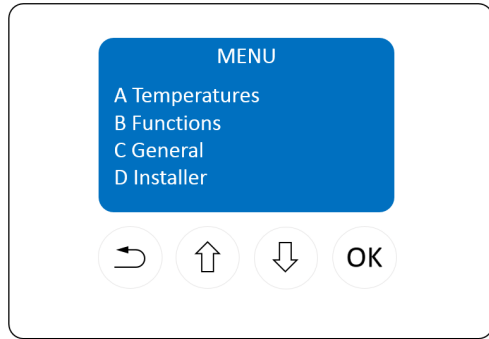

Figure 19 - Main menu

7.4.1. Temperatures

The temperature set points can be changed under the menu point “temperatures”.

Different temperature set points can be adjusted according to the relative mode of operation. All temperatures are in °C.

Code	Set point name	Description	Range	Factory setting
A1	T AUTO	The temperature level at which the unit heats the water when the AUTO mode is selected. The unit starts if the temperature of the water in T3 falls of 5 °C below the set point.	50 - 60	53
A2	T ECO	The temperature level at which the unit heats the water when the ECO mode is selected. The unit starts if the temperature of the water in T3 falls of 5 °C below the set point.	50 - 55	50
A3	T BOOST	The temperature level at which the unit heats the water when the BOOST mode is selected. The unit starts if the temperature of the water in T3 falls of 5 °C below the set point.	50 - 65	55

7.4.2. Functions

The functions are similar to the modes of operation but they cannot be accessed directly from the home view and they can vary from unit to unit.

In addition, since SOLAR, FLOOR and COOLING (called extra functions) can not be used simultaneously, the choice of these functions should be made from the Installer menu (D26 Extra function). In the function menu, only one of these extra function is normally shown. The function menu is described in the following table.

Code	Set point name	Description	Range	Factory setting	
B1	OFF	The fan switches off when the heat pump does not run.	OFF/ Single Speed/ 2Speeds	OFF	
	Single speed	The fan is always running at a single fixed speed (B2 Fan speed), both when the heat pump is operating and when it is not.			
	2 Speeds	The fan is always in operation but it runs normally at a higher speed D6 (Fan AUTO Speed) when the heat pump starts operating and at (B2 Fan speed) when it is not operating.			
B2	Fan speed	The main fan speed regulation for the ventilation function. There are three ventilation level that can be selected: LOW D5 (Min Fan Speed), MEDIUM D4 (Fan medium speed) HIGH D3 (Max fan speed).	LOW/ MEDIUM/ HIGH	HIGH	
B3	Low Tariff	Standard	The low tariff allows the electric heater and the heat pump to run only during periods with low electricity prices, according to the menu item that regulate the program of the low tariff D17/D18 (Low tariff weekday/weekends). The unit runs only during pre-defined hours of the day. If the PV function (B5) is active, this allows the electric heater and the heat pump to run outside the low tariff period.	OFF/ STANARD/ OPTIMAL 1/ OPTIMAL 2	OFF
		Optimal 1	This function allows the maximum exploitation of the lower electricity price during the night periods between 00:00 and 05:00.		
		Optimal 2	This function allows the maximum exploitation of the lower electricity price during the night periods between 00:00 and 05:00. During the day, the unit works according to Low Tariff periods D17 and D18.		

Code	Set point name	Description	Range	Factory setting
B4	Hot on time	The unit can be programmed to deliver hot water from 1 to 30 days from the moment in which the function is activated and the HOLIDAY mode is selected. The unit switches to AUTO MODE in the desired number of days. If OFF is selected, the function is not active.	OFF/ON	OFF
B5	Photovoltaic			
	OFF*	The PV function is not active. If this function is activated, the heat pump and the electric heater can start only if the input voltage in GC1 (0-10V) is higher than D20/D21 (PV min Voltage HP/EL) for longer than D22 (PV min time).	OFF/ECO/STORAGE	OFF
	PV ECO*	The PV function allows for water heating only with the heat pump until temperature set point defined by the MODE of operation is reached.		
PV STORAGE*	The PV function allows for water heating to the maximum temperature level, giving priority to the operation of the heat pump if the BOOST or BACK UP mode is not active. The heat pump operates alone until the max allowed temperature for the heat pump operation D33 (T HP Max) is reached. The electric heater operates only from D33 to the maximum allowable temperature D9 (Water T max).			
B6	Solar*	The Solar function allows the water to be heated up by the solar collector, activating a water pump controlled by the extra relay (GP1). The pump starts when $T5 > T3 + D24$ (Solar DT min). The pump stops if the temperature in the tank goes above D23 (Solar T max) or if T5 is below T3.	OFF/ON	OFF
B7	Floor*	The floor heating function activates an external circulation pump. If the temperature at the bottom of the tank T4 (T water b) is higher than the setting menu D25 (Floor T start) the floor heating function is activated. If the extra temperature T5 (T Extra) is higher than the floor heating temperature (B8 T floor) the circulation pump (Extra relay GP1) stops.	OFF/ON	OFF

Code	Set point name	Description	Range	Factory setting
B8	Floor T*	The desired floor heating temperature in °C with hysteresis of 1K.	15 - 40	35
B9	Cooling*	The Cooling function can be activated. See installer menu D28 (Cooling type).	OFF/ON	OFF
B10	Cooling T*	The air temperature set point (°C) below which the heat pump stops, when the unit is in the Cooling function.	10 - 30	21

7.4.3. General

The general section collects all the standard settings that have little or no effect on the heat pump operation, except for the menu item Reset.

Activating the Reset function brings all the set points to the factory settings value.

The set points of the General menu are described in the Table below

Code	Set point name	Description	Range	Factory setting
C0	Reset	The set points in the user menu are reset. The more advanced settings can be reset only from the installer menu. The information as number of hours of the compressor and fan cannot be reset.	OFF/ON	OFF
C1	Info	The software version is displayed.	-	-
C2	Time	The time can be adjusted here.	-	-
C3	Date	The date can be adjusted here.	-	-
C4	Day	The day of the week can be selected.	-	Monday
C5	Language	More languages can be selected.	-	English
C6	Contrast	The contrast of the screen can be adjusted.	0-10	5

7.4.4. Installer

The installer menu should be accessed only by qualified personnel. Some of the set points that can be regulated from this menu can have large effects on the unit performance depending on the type of commissioning and installation. There should be a proper match between installer set points and type of installation in order to optimize the performance and lifetime of the unit.

In order to access the Installer Menu, a 4-digits password needs to be entered. The password is: 2016. All temperatures are expressed in °C.

Code	Set point name	Description	Range	Factory setting	
D0	Reset all	All the set points are reset to original factory settings. Also the Information menu and the installer set points are modified.	OFF/ON	OFF	
D1	Errors	The alarms of the unit can be checked here.	-	-	
D2	Modbus	D2.0 Address	Modbus address. The Modbus address can be set between 1 and 247.	1-247	30
		D2.1 Baud Rate	Modbus baud rate. The Modbus baud rate can be set between 19200 and 9600.	9600/19200	19200
		D2.2 Parity	Modbus parity. The Modbus parity can be set between Even or Odd or deactivated.	Even/Odd/None	Even
		D2.3 Write enable	Modbus modify. If this function is activated, it is possible to modify the set points kept for development with a data logger.	OFF/ON	ON
D3	Fan max speed	The maximum fan speed (%) can be regulated. This is the highest limit at which the fan can run both when the ventilation function is active and when the heat pump is in standard operation.	0-100	70 (outdoor)	
D4	Fan medium speed	The medium fan speed (%) can be adjusted.	0-100	50 (outdoor)	
D5	Fan min speed	The minimum fan speed (%) can be adjusted.	0-100	40 (outdoor)	
D6	AUTO speed	The automatic speed of the fan (%) when the heat pump is running in AUTO and ECO mode can be regulated. This is a nominal value while the fan speed may automatically vary its speed at a higher level, depending on the operating conditions.	0-100	57 (indoor)/48 (outdoor)	

Code	Set point name	Description	Range	Factory setting
D7	Air T min	The minimum air temperature allowed during the operation of the heat pump can be regulated here. If T1 is below Air T min the electric heater starts and it works alone until the set point is reached. (Even if the air temperature increases in the meanwhile).	(-7) - (+10)	-7
D8	Air T max	The maximum air temperature allowed during the operation of the heat pump can be regulated here.	30-40	40
D9	Water T max	The maximum allowed temperature in the tank.	55-65	65
D10	Defrosting T Stop	The temperature of T2 at which the defrosting function stops. The defrosting function is automatic and it occurs not more often than once every hour.	0-10	4
D11	Evaporator T max	The maximum evaporator temperature allowed during the operation of the heat pump can be regulated here. If T2 has a higher temperature than the set point, then use electric heater. This function is active 10 minutes after the compressor start.	10-40	30
D12	BACK-UP T	The water temperature at which the unit stops the backup mode with only the electric heater.	0-65	35
D13	Legionella	The legionella function can be activated. The legionella function does not switch the heat pump on, but just continues the heat up cycle to a higher temperature D14 (Legionella T). The legionella operation works only with the heat pump until 60°C. The remaining temperature lift is accomplished with the electric heater alone.	OFF/ON	OFF
D14	Legionella T	The legionella temperature set point can be regulated.	60-65	60
D15	Legionella date	The legionella week day can be set	Monday/Sunday	Sunday

Code	Set point name	Description	Range	Factory setting
D16	Forced operation	The forced operation of the heat pump can be activated here. The heat pump starts even if there is not need for hot water. When the maximum temperature allowed by the heat pump is reached the unit will stop. This function is to use for testing purposes. It becomes OFF again after one heat up cycle is completed.	OFF/ON	OFF
D17	Low Tariff weekday	The start and stop time of the low electricity tariff period for weekdays. Three periods can be selected.	0-23 0-23 0-23	0 0 0
D18	Low Tariff weekend	The start and stop time of the low electricity tariff period for weekends. Three periods can be selected.	0-23 0-23 0-23	0 0 0
D19	Light Saving Time	Light Saving Time can be deactivated.	OFF/ON	ON
D20	PV min Voltage HP*	The minimum voltage (V) required to start the HP when the PV function is active.	0-10	0
D21	PV min Voltage EL*	The minimum voltage (V) required to start the electric heater when the PV function is active.	0-10	0
D22	PV min time*	The minimum time (minutes) at which the input voltage from the PV panel should be above the set point D20/D21 (PV min Voltage HP/EL) in order to start the electric heater or heat pump when the PV function is active. D22 also regulates the minimum heat pump operational time when started by the PV function.	1-120	15
D23	Solar T max*	The maximum allowed temperature (°C) in the solar collector.	55-89	89
D24	Solar DT min*	The minimum temperature (°C) difference between solar collector and tank.	1-5	5
D25	Floor T start*	The temperature (°C) that needs to be in the tank to allow the floor function to be active with hysteresis of 1K.	25-45	35

Code	Set point name	Description	Range	Factory setting
D26	Extra function*	The desired extra function is selected here. The possible functions are Solar, Floor or Cooling. Once the function is activated, move to the function menu and adjust the set point as desired.	OFF/ Solar/ Floor/ Cooling	OFF
D27	SG Ready	The SG ready function can be activated by the installer here. Three possible modes can be selected. This function allows the start of the heat pump from an external access (See QA1 in Figure 16). SG ready is not active if there is not external input (SG1 OFF, SG2 OFF).	OFF/ SG Boost/ SG Eco/ SG Block	OFF
	(SG BOOST)*	The heat pump and electric heater must start, if below the max water temperature allowed in the tank. Both Heat Pump and Electric heater are forced to operate (SG1 ON and SG2 ON).		
	(SG ECO)*	The heat pump operates minimizing costs, only the heat pump is activated (SG1 OFF, SG2 ON).		
	(SG BLOCK)*	The unit can be stopped even if there is a need for hot water (SG1 ON, SG2 OFF).		
D28	Cooling Type	The fan and heat pump run until the additional temperature T5 placed in the room environment is below a certain level. The water temperature can only reach the maximum temperature allowed in the tank D33 (T HP max). The cooling function activates a three-way damper, which directs the cold exhaust air to a room with cooling requirements. The two functions operate the damper in opposite directions.	Cooling1/ Cooling2	Cooling 1
	Cooling 1*	Cooling 1 (2). If the T5 is higher than B10 T Cooling, the extra relay that operates the damper (GP1) switches ON (OFF). If the T5 is lower than B10 (T Cooling), the extra relay that operate the damper (GP1) switches OFF (ON).		

Code	Set point name	Description	Range	Factory setting
D29	OFF*	Normal operation.	OFF/ Hygrostat/ Ventilation Max/ Start-Stop	OFF
	Hygrostat*	The fan always runs according to the input signal in GC1 (0-10V) from an external hygrostat, CO ₂ -sensor or similar appliances. 1. If the voltage is between 0 - 3.0 V the fan speed is D5 (Fan min speed). 2. If the voltage is between 3.0 - 8.0 the fan speed is D4 (Fan medium speed). 3. If the voltage is higher than 8 V the fan speed is D3 (Fan max speed).		
	Ventilation max*	If the ventilation function is already selected, a signal higher of 2V to GC1 leads to maximum air flow.		
	Start/stop*	If GC1 receives a signal higher than 2V, the unit operation is stopped.		
D30	Filter timer	The filter function is activated (ON) or deactivated (OFF).	OFF/ON	OFF
D31	Filter timer time	If the filter function is ON then the timer of the filter can be selected. This set point determines the number of months after which the filter alarm is displayed.	0-12	3
D32	Filter reset	Once the air filter has been replaced, activate this function to reset the filter timer.	OFF/ON	OFF
D33	T HP max	The maximum water temperature that can be reached by the heat pump in °C .	50-65	60

7.5. Defrosting

When the evaporation temperature (T2) falls below 0°C, the evaporator starts to accumulate ice on its fins. In order to maintain the unit reliable and well performing, an automatic defrosting operation is activated.

Defrosting can occur between 60 minutes and 120 minutes from the last defrosting or from the last moment in which the evaporation temperature was above 0°C.

Defrosting can occur with two different strategies according to the conditions of the inlet air.

- 1) If the air temperature is above 4°C, then the defrosting occurs running both compressor and fan. The fan runs at speed D3 (Fan max speed).
- 2) If the air temperature is below 4°C, then the defrosting occurs running the compressor and stopping the fan.

Before defrosting is completed the fan stops for a short period to allow the excess water in the unit to leave the unit from the condensate drain. Defrosting automatically stops when the temperature of the evaporator (T2) becomes higher than the set point (D10).

7.6. Photovoltaic Function

The domestic hot water heat pump (DHWHP) can be controlled by a signal from a solar photovoltaic (PV) converter or an energy meter, either as simple start/stop via a potential free contact or by a variable signal.

Figure 20 represents possible installation configurations with or without energy meter.

Using the variable signal option, a certain output (DC or mA) from the (PV) inverter or the energy meter corresponds to a given amount of excess power for use in the DHWHP. This excess power can be used to activate either the electrical immersion heater, the heat pump (HP) or both.

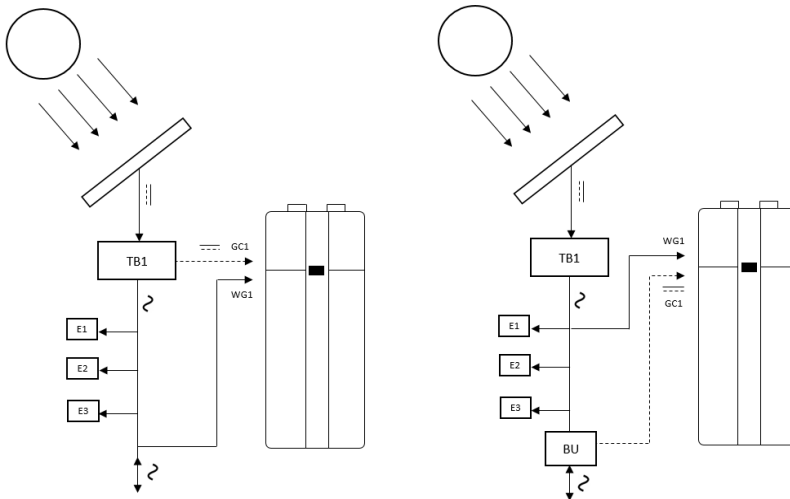

Figure 20 – PV installation 1: control signal from inverter. PV installation 2: control signal from energy meter.

TB1: DC/AC Inverter

BU: Energy meter

E1-2-3: Electric loads

WG1: Heat pump power supply

GC1: Photovoltaic function input signal (0-10 VDC , 0-3 VDC , 4-20 mA).

7.7. Safety features

7.7.1. High pressure switch

In order to ensure that the compressor does not run beyond its operating envelope there is a built-in high pressure switch which shuts down the compressor when the pressure in the cooling circuit becomes too high. The pressure switch shuts down the compressor if the pressure gets higher than 2.0 MPa.

To restart the unit, the power must be switched off and switched on again.

7.7.2. Safety breakers

In the event of a failure on the electrical immersion heater, the safety breakers will shut down the unit. If the set value (80°C) is exceeded, the electrical immersion heater will disconnect. The electrical immersion heater can be reactivated when the temperature is below 80°C.

To do this, the power to the unit must be switched off and the front panel dismantled. Then the reset buttons in the center of the breakers can be pressed. This must only be performed by skilled personnel.

Moreover, an additional thermal safety breaker switches off the compressor in case the compressor surface reaches temperatures above 160°C

7.7.3. Alarms

Alarm	Meaning	Possible reasons	Possible solutions
Er1, Er2, Er3, Er4, Er5	Temperature sensors out of range	The temperature sensor T1, T2, T3, T4* or T5* is defective or not connected to the PCB	Check that the sensor is connected to the PCB
			Substitute the temperature sensor
Err HP	High pressure switch	High pressure in the cooling system	Reduce the water temperature setpoint
		High pressure switch BP1 is defective or not connected to the PCB	Reduce the fan maximum speed in the installer menu
Er 7 - Err Evap / Er9 - Err H Evap	High evaporator temperature	Wrong position of the temperature sensor	Check that T2 is positioned in the evaporator
		Leakage of refrigerant	Fix leakages and charge refrigerant
Err C Evap	Low evaporation temperature	Mal-functioning fan	Make sure that the fan is connected to the PCB or substitute the component
		Low air flow	Increase the minimum fan speed in the installer menu
		Low air inlet temperature T1	Increase the minimum air temperature in the installer menu
Er10 - Filter	Change filter	Substitute the air filter	

8. MAINTENANCE

Please observe local rules and regulations regarding potential periodically inspection of the heat pump by skilled personnel.

8.1. Environmental requirements

When repairing or dismantling the domestic hot water heat pump please follow the environmental regulations and legal requirements in relation to recycling and disposal of materials.

8.2. Cooling system and fan

Servicing primarily consists of cleaning of the evaporator if no air filter is installed. Remove the top plate of the unit. Relocate cables from the top part of the EPS housing. Remove the top part of the EPS housing off the unit. Clean the evaporator and fan with a brush or a bottle brush.

Be carefull using cleaning spray. The may contain chemicals that can damage EPS parts. If in doubt, check the spray on a small EPS.

Be careful not to remove balancing weights on the fan wheel during this process, as this will cause fan imbalance and lead to a higher noise level as well as wear and tear on the fan.

8.3. Condensation and condensate drain

Together with inspecting and cleaning of the fan, the condensate drain shall be cleaned of dirt.

Pour some water in the lower half of the EPS part and check if the water flows freely. If not, then the drain must be cleaned.

8.4. Water circulation and water tank

8.4.1. Pressure relief valve

Your installer has installed a pressure relief valve near the cold water connection on the domestic hot water tank to protect the water tank against excessive pressures when the domestic water expands during the heating process.

The back pressure valve (check valve), which is installed in front of the pressure relief valve on the cold water pipe, prevents water from the tank flowing back into the cold water pipe. Therefore, the pressure in the water tank rises to the maximum setting of the pressure relief valve and the pressure relief valve opens. The redundant water discharges. If the pressure relief valve did not open, the water tank would burst.

The pressure relief valve must be operated regularly to remove lime deposits and to verify that it is not blocked. It is tested by pressing the lever/turning the handle on the pressure relief valve while checking that water discharges. Damages due to a faulty pressure relief valve are not covered by the warranty.

Please note that water may drip from the discharge pipe of the pressure-relief valve due to heating of the water.

8.4.2. Anode

In order to prevent corrosion of the enameled hot water tank, a magnesium anode is installed behind the front panel at the top half of the water tank.

The anode has a life expectancy of approximately 2-5 years depending on the water quality.

It is recommended to inspect the anode every year.

- 1) Disconnect the electrical power supply or pull out the power plug.
- 2) Remove the plastic front cover. This allows access to the anode.
- 3) Disconnect the wire connection between the anode and the tank (see pictures below).
- 4) Insert a multimeter (range mA) between the anode and the tank. Anode current > 0.3 mA: Anode is active and ok. Anode current < 0.3 mA: Anode should be checked and possibly be replaced.
- 5) Reconnect the wire connection between the anode and the tank. Close the front cover and switch on the unit.

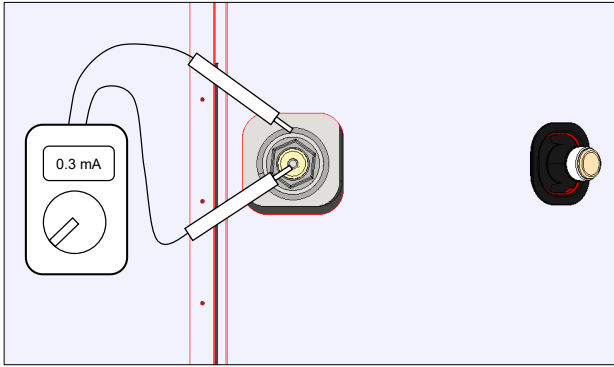

Figure 22 - Anode control

Please note that the water has to be heated to operational temperatures at least once before the test above can be performed.

In order to replace the anode the following should be done:

- Close the cold water inlet.
- Connect a hose to the drain valve so the water from the water tank can run into the nearest drain.
- Open a hot water tapping point (to avoid vacuum in the water tank).
- When the water level in the tank is below the anode, this can be removed for inspection and replacement.

Check and replacement of anode must only be performed by skilled personnel.

9. DISASSEMBLY & DECOMMISSIONING

The following must be done during decommissioning:

- Disconnect the unit from the power mains - i.e. the electrical cables are removed.
- Close the cold water supply and attach a hose to the drain valve, so that water from the tank can run to the nearest drain.
- Remove the water and heating pipes.
- Remove the air ducts and close all supply and extract air dampers so that no condensation forms in the ducts.

The unit has to be decommissioned in the most environmentally proper manner. When the product is discarded, please observe the local municipal waste removal regulations.

10. TROUBLESHOOTING

In addition check out the following questions before contacting an installer:

- Is the cold water supply open?
- Has the periodic cleaning of evaporator, condensation drain and fan as described in the maintenance section been followed?
- Has any of the safety features disengaged the heat pump/electrical immersion heater?
- Has external short-circuiting of terminals disengaged the heat pump?
- Has factory resetting been tested?
- If it is not one of the above errors, please contact:

In the warranty period (0-2 years): The installer, from which the unit was purchased.

After the warranty period (> 2 years): The installer from which the unit was purchased or partners of the manufacturer.

Please have data from name plate ready (silver plate on the unit).

Problem	Possible reasons	Possible solutions
The product does not supply hot water	The unit is not connected to the power supply	Make sure the display turns ON
	Alarms from the controller stop the operation of the unit	Check the alarms in the Info menu Er
	Low water temperature set points	Increase all temperature set points in menu A Temperatures
	Low airflow in evaporator	Clean the evaporator and the air ducts
	Fan does not work	Make sure that the fan is connected to the PCB or substitute the component.
	SG Ready function is active	Switch OFF SG Ready function
	Thermal safety switch FN1 opens and stops the power supply to the electric heater	Restore the original conditions of the thermal safety switch FN1.
High sound emissions	Too high maximum fan speed	Reduce the fan maximum speed in the Installer menu
		Activate the SILENT mode
	Obstruction of the air ducts.	Remove the obstruction
	Dirt on fan or evaporator.	Clean the evaporator and the fan. Do not use cleaning spray that can be damage the EPS housing
Components vibration	Make sure all components as compressor and solenoid valve are well fastened	

13. PRODUCT AND INSTALLER INFORMATION

Installed model: _____

Serial number: _____

Accessories: _____

Installers

Pipe installation

Date: _____

Company: _____

Name: _____

Phone number: _____

Electrical installation

Date: _____

Company: _____

Name: _____

Phone number: _____

Commissioning

Date: _____

Company: _____

Name: _____

Phone number: _____



NIBE Energy Systems
Box 14, Hannabadsvägen 5
285 21 Markaryd

info@nibe.se
www.nibe.se