

# Air/water heat pump

## NIBE F2120 *8, 12, 16, 20*





# Table of Contents

1	<i>Important information</i>	4	Optional connections	30
	Safety information	4	Connecting accessories	33
	Symbols	4		
	Marking	4	6 <i>Commissioning and adjusting</i>	34
	Safety precautions	4	Preparations	34
	Serial number	6	Balance temperature	34
	Recovery	6	Filling and venting	34
	Environmental information	6	Start-up and inspection	35
	Inspection of the installation	7	Readjusting, heating medium side	35
	Compatible indoor modules (VVM) and control modules (SMO)	8	Adjustment, charge flow	36
	Indoor module	9	7 <i>Control - Introduction</i>	37
	Control module	9	General	37
2	<i>Delivery and handling</i>	10	LED status	37
	Transport and storage	10	Master control	38
	Assembly	10	Control conditions	39
	Compressor heater	11	Control - Heat pump EB101	40
	Condensation	11	8 <i>Disturbances in comfort</i>	42
	Installation area	14	Troubleshooting	42
	Supplied components	15	9 <i>Alarm list</i>	46
	Removing the side cover and top panel	16	10 <i>Accessories</i>	49
3	<i>The heat pump design</i>	17	11 <i>Technical data</i>	50
	General	17	Dimensions	50
	Distribution box	21	Sound levels	51
4	<i>Pipe connections</i>	22	Technical specifications	52
	General	22	Working area	55
	Pipe coupling heating medium circuit	22	Heating	56
	Pressure drop, heating medium side	23	Cooling	58
	Heat insulation	23	Energy labelling	59
	Installing flex hoses	23	Electrical circuit diagram	64
5	<i>Electrical connections</i>	24	<i>Item register</i>	72
	General	24	<i>Contact information</i>	75
	Accessibility, electrical connection	25		
	Configuration using DIP switch	26		
	Connections	27		

# 1 Important information

## Safety information

This manual describes installation and service procedures for implementation by specialists.

The manual must be left with the customer.

This appliance can be used by children aged from 8 years and above and persons with reduced physical, sensory or mental capabilities or lack of experience and knowledge if they have been given supervision or instruction concerning use of the appliance in a safe way and understand the hazards involved. The product is intended for use by experts or trained users in shops, hotels, light industry, farming and similar environments.

Children must be instructed/supervised to ensure that they do not play with the appliance.

Do not allow children to clean or maintain the appliance unsupervised.

This is an original manual. It may not be translated without the approval of NIBE.

Rights to make any design or technical modifications are reserved.

©NIBE 2020.

Electrical installation and wiring must be carried out in accordance with the stipulations in force.

F2120 must be installed via an isolator switch. The cable area has to be dimensioned based on the fuse rating used.

If the supply cable is damaged, only NIBE, its service representative or similar authorised person may replace it to prevent any danger and damage.

## Symbols



### NOTE

This symbol indicates danger to person or machine .



### Caution

This symbol indicates important information about what you should consider when installing or servicing the installation.



### TIP

This symbol indicates tips on how to facilitate using the product.

## Marking

**CE** The CE mark is obligatory for most products sold in the EU, regardless of where they are made.

**IP24** Classification of enclosure of electro-technical equipment.



Danger to person or machine.



Read the User Manual.



Read the Installer Manual.

## Safety precautions

### CAUTION

**Install the system in full accordance with this installation manual.** Incorrect installation can cause bursts, personal injury, water leaks, refrigerant leaks, electric shocks and fire.

**Pay attention to the measurement values before working on the cooling system, especially when servicing in small rooms, so that the limit for the refrigerant's concentration is not exceeded.**

Consult an expert to interpret the measurement values. If the refrigerant concentration exceeds the limit, there may be a shortage of oxygen in the event of any leak, which can cause serious injury.

**Use original accessories and the stated components for the installation.**

If parts other than those stated by us are used, water leaks, electric shocks, fire and personal injury may occur as the unit may not work properly.

**Ventilate the working area well – refrigerant leakage may occur during service work.**

If the refrigerant comes into contact with naked flames, poisonous gas is created.

**Install the unit in a location with good support.**

Unsuitable installation locations can cause the unit to fall and cause material damage and personal injury. Installation without sufficient support can also cause vibrations and noise.

**Ensure that the unit is stable when installed, so that it can withstand earthquakes and strong winds.**

Unsuitable installation locations can cause the unit to fall and cause material damage and personal injury.

**The electrical installation must be carried out by a qualified electrician and the system must be connected as a separate circuit.**

Power supply with insufficient capacity and incorrect function can cause electric shocks and fire.

**Use the stated cables for the electrical connection, tighten the cables securely in the terminal blocks and relieve the wiring correctly to prevent overloading the terminal blocks.**

Loose connections or cable mountings can cause abnormal heat production or fire.

**Check, after completed installation or service, that no refrigerant leaks from the system in gas form.**

If refrigerant gas leaks into the house and comes into contact with an aereotemp, an oven or other hot surface, poisonous gases are produced.

**Switch off the compressor before opening/breaching the refrigerant circuit.**

If the refrigerant circuit is breached /opened whilst the compressor is running, air can enter the process circuit. This can cause unusually high pressure in the process circuit, which can cause bursts and personal injury.

**Switch off the power supply in the event of a service or inspection.**

If the power supply is not shut off, there is a risk of electric shocks and damage due to the rotating fan.

**Do not run the unit with removed panels or protection.**

Touching rotating equipment, hot surfaces or high voltage parts can cause personal injury due to entrapment, burns or electric shocks.

**Cut the power before starting electrical work.**

Failure to cut the power can cause electric shocks, damage and incorrect function of the equipment.

## CARE

**Carry out the electrical installation with care.**

Do not connect the ground lead to the gas line, water line, lightning conductor or telephone line's ground lead. Incorrect grounding can cause unit faults such as electric shocks due to short-circuiting.

**Use main switch with sufficient breaking capacity.**

If the switch does not have sufficient breaking capacity, malfunctions and fire can occur.

**Always use a fuse with the correct rating in the locations where fuses are to be used.**

Connecting the unit with copper wire or other metal thread can cause unit breakdown and fire.

**Cables must be routed so that they are not damaged by metal edges or trapped by panels.**

Incorrect installation can cause electric shocks, heat generation and fire.

**Do not install the unit in close proximity to locations where leakage of combustible gases can occur.**

If leaking gases collect around the unit, fire may occur.

**Do not install the unit where corrosive gas (for example nitrous fumes) or combustible gas or steam (for example thinner and petroleum gases) can build up or collect, or where volatile combustible substances are handled.**

Corrosive gas can cause corrosion to the heat exchanger, breaks in plastic parts etc. and combustible gas or steam can cause fire.

**Do not use the unit where water splashes may occur, for example in laundries.**

The indoor section is not waterproof and electric shocks and fire can therefore occur.

**Do not use the unit for specialist purposes such as for storing food, cooling precision instruments, freeze-conservation of animals, plants or art.**

This can damage the items.

**Do not install and use the system close to equipment that generates electromagnetic fields or high frequency harmonics.**

Equipment such as inverters, standby sets, medical high frequency equipment and telecommunications equipment can affect the unit and cause malfunctions and breakdowns. The unit can also affect medical equipment and telecommunications equipment, so that it functions incorrectly or not at all.

**Do not install the outdoor unit in the locations stated below.**

- Locations where leakage of combustible gas can occur.
- Locations where carbon fibre, metal powder or other powder that can enter the air.
- Locations where substances that can affect the unit, for example, sulphide gas, chlorine, acid or alkaline substances can occur.
- Locations with direct exposure to oil mist or steam.
- Vehicles and ships.
- Locations where machines that generate high frequency harmonics are used.
- Locations where cosmetic or special sprays are often used.
- Locations that can be subjected to direct salty atmospheres. In this case, the outdoor unit must be protected against direct intakes of salty air.
- Locations where large amounts of snow occur.
- Locations where the system is exposed to chimney smoke.

**If the bottom frame of the outdoor section is corroded, or in any other way damaged, due to long periods of operation, it must not be used.**

Using an old and damaged frame can cause the unit to fall and cause personal injury.

**If soldering near the unit, ensure that solder residue does not damage the drip tray.**

If solder residue enters the unit during soldering, small holes can appear in the tray resulting in water leakage. To prevent damage, keep the indoor unit in its packing or cover it.

**Do not allow the drainage pipe to exit into channels where poisonous gases, containing sulphides for example, can occur.**

If the pipe exits into such a channel, any poisonous gases will flow into the room and seriously affect the user's health and safety.

**Insulate the unit's connection pipes so that the ambient air moisture does not condense on them.**

Insufficient insulation can cause condensation, which can lead to moisture damage on the roof, floor, furniture and valuable personal property.

**Do not install the outdoor unit in a location where insects and small animals can inhabit.**

Insects and small animals can enter the electronic parts and cause damage and fire. Instruct the user to keep the surrounding equipment clean.

**Take care when carrying the unit by hand.**

If the unit weighs more than 20 kg, it must be carried by two people. Wear safety gloves to minimise the risk of cuts.

**Dispose of any packaging material correctly.**

Any remaining packaging material can cause personal injury as it may contain nails and wood.

**Do not touch any buttons with wet hands.**

This can cause electric shocks.

**Do not touch any refrigerant pipes with your hands when the system is in operation.**

During operation the pipes become extremely hot or extremely cold, depending on the method of operation. This can cause burn injuries or frost injuries.

**Do not shut off the power supply immediately after operation has start.**

Wait at least 5 minutes, otherwise there is a risk of water leakage or breakdown.

**Do not control the system with the main switch.**

This can cause fire or water leakage. In addition, the fan can start unexpectedly, which can cause personal injury.

# Serial number

The serial number can be found at the top left on the rear cover and at the bottom on the side.

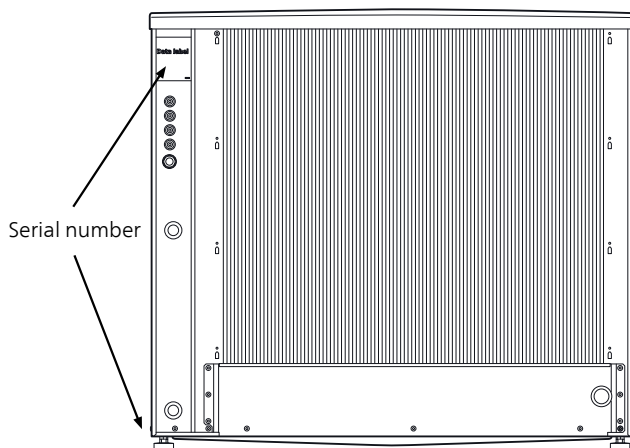

## Caution

You need the product's (14 digit) serial number for servicing and support.

# Recovery



Leave the disposal of the packaging to the installer who installed the product or to special waste stations.

Do not dispose of used products with normal household waste. It must be disposed of at a special waste station or dealer who provides this type of service.

Improper disposal of the product by the user results in administrative penalties in accordance with current legislation.

# Environmental information

This unit contains a fluorinated greenhouse gas that is covered by the Kyoto agreement.

The equipment contains R410A, a fluorinated greenhouse gas with a GWP value (Global Warming Potential) of 2088. Do not release R410A into the atmosphere.

# Inspection of the installation

Current regulations require the heating installation to be inspected before it is commissioned. The inspection must be carried out by a suitably qualified person. Fill in the page for information about installation data in the User manual.

✓	Description	Notes	Signature	Date
	Heating medium (see section "Pipe connections")			
	System flushed			
	System vented			
	Particle filter			
	Shut-off and drain valve			
	Charge flow set			
	Electricity (see section "Electrical connections")			
	Fuses property			
	Safety breaker			
	Earth circuit-breaker			
	Heating cable type/effect			
	Fuse size, heating cable (F3)			
	Communication cable connected			
	F2120 addressed (only when cascade connection)			
	Connections			
	Main voltage			
	Phase voltage			
	Miscellaneous			
	Condensation water pipe			
	Insulation condensation water pipe, thickness (if KVR 10 is not used)			



## NOTE

Check the connections, main voltage and phase voltage before the machine is started, to prevent damage to the heat pump electronics.

# Compatible indoor modules (VVM) and control modules (SMO)

	VVM S320	SMO S40
F2120-8	X	X
F2120-12	X	X
F2120-16	X	X
F2120-20		X

	VVM 225	VVM 310	VVM 320	VVM 500	SMO 20	SMO 40
F2120-8	X	X	X	X	X	X
F2120-12		X	X	X	X	X
F2120-16		X	X	X	X	X
F2120-20				X	X	X



# Indoor module

## VVM S320

Stainless steel, 3x230 V

Part no. 069 201

## VVM S320

Enamel, 3x400 V

Part no. 069 206

## VVM S320

Stainless steel, 3x400 V

Part no. 069 196

## VVM 225

Enamel, 3x400 V

Part no. 069 227

## VVM 225

Stainless steel, 3x400 V

Part no. 069 229

## VVM 310

Stainless steel, 3x400 V

Part no. 069 430

## VVM 310

Stainless steel, 3x400 V

With integrated EMK 310

Part no. 069 084

## VVM 320

Stainless steel, 1x230 V

Part no. 069 111

## VVM 320

Stainless steel, 3x230 V

Part no. 069 113

## VVM 320

Enamel, 3x400 V

With integrated EMK 300

Part no. 069 203

## VVM 320

Stainless steel, 3x400 V

Part no. 069 109

## VVM 320

Copper, 3x400 V

Part no. 069 108

## VVM 500

Stainless steel, 3x400 V

Part no. 069 400

# Control module

## SMO S40

Control module

Part no. 067 654

## SMO 20

Control module

Part no. 067 224

## SMO 40

Control module

Part no. 067 225

# 2 Delivery and handling

## Transport and storage

F2120 must be transported and stored vertically.



### NOTE

Ensure that the heat pump cannot fall over during transport.

Ensure that the heat pump cannot be damaged during transportation.

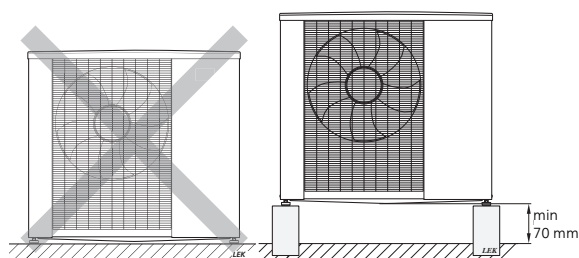

Do not place F2120 directly on the lawn or other non solid surface.

## Assembly

- Place F2120 outdoors on a solid level base that can take the weight, preferably a concrete foundation. If concrete slabs are used they must rest on asphalt or shingle.
- The lower edge of the evaporator must be at the level of the average local snow depth. The concrete foundation or concrete plinths must therefore be at least 70 mm high.
- F2120 should not be positioned next to noise sensitive walls, for example, next to a bedroom.
- Also ensure that the placement does not inconvenience the neighbours.
- F2120 must not be placed so that recirculation of the outdoor air can occur. This causes lower output and impaired efficiency.
- The evaporator must be sheltered from direct wind / , which negatively affects the defrosting function. Place F2120 protected from wind / against the evaporator.
- Some water may drip from the drainage hole under F2120. Make sure that the water can run away by selecting a suitable material underneath F2120 (see section Condensation).
- Care must be exercised so that the heat pump is not scratched during installation.

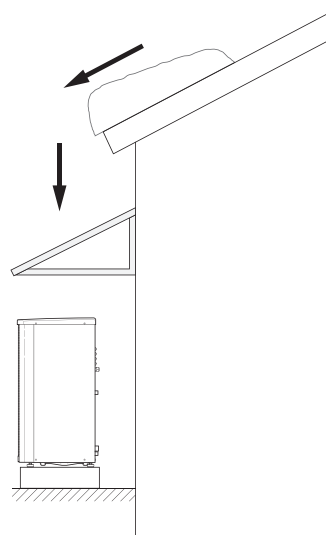

If there is a risk of snow slip from roof, a protective roof or cover must be erected to protect the heat pump, pipes and wiring.

## LIFT FROM THE STREET TO THE SET UP LOCATION

If the base allows, the simplest thing is to use a pallet truck to move the F2120 to the set up location.



### NOTE

The centre of gravity is offset to one side (see print on the packaging).

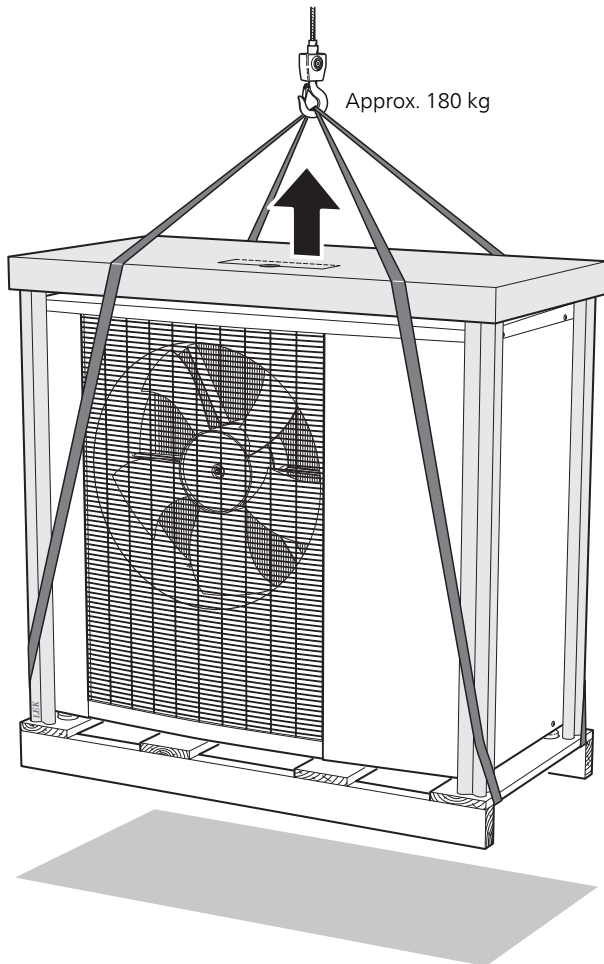

If F2120 needs to be transported across soft ground, such as a lawn, we recommend that a crane is used that can lift the unit to the installation location. When F2120 is lifted with a crane, the packaging must be undisturbed, see the illustration above.

If a crane vehicle cannot be used the F2120 can be transported on an extended sack truck. F2120 must be taken from its heaviest side and two people are required to lift F2120.

## LIFT FROM THE PALLET TO FINAL POSITIONING

Before lifting remove the packaging and the securing strap to the pallet.

Place lifting straps around each machine foot. Lifting from the pallet to the base requires four persons, one for each lifting strap.

## SCRAPPING

When scrapping, the product is removed in reverse order. Lift by the bottom panel instead of a pallet!

## Compressor heater

F2120 is equipped with two compressor heaters that heat the compressor before start-up and when the compressor is cold.



### NOTE

The compressor heater must have been active for approx. 3 hours before the first start, see section "Start-up and inspection".

## Condensation

The condensate drain pan collects and leads away the condensation water.



### NOTE

It is important to the heat pump function that condensation water is led away and that the drain for the condensation water run off is not positioned so that it can cause damage to the house.

Condensation run-off should be checked regularly, especially during the autumn. Clean if necessary.



### NOTE

The electrical installation and wiring must be carried out under the supervision of an authorised electrician.



### TIP

Pipe with heating cable for draining the condensation water trough is not included.

To ensure this function the accessory KVR 10 should be used.

- The condensation water (up to 50 litres/24 hrs) that collects in the trough should be routed away by a pipe to an appropriate drain, it is recommended that the shortest outdoor stretch possible is used.
- The section of the pipe that can be affected by frost must be heated by the heating cable to prevent freezing.
- Route the pipe downward from F2120.
- The outlet of the condensation water pipe must be at a depth that is frost free or alternatively indoors (with reservation for local ordinances and regulations).

- Use a water trap for installations where air circulation may occur in the condensation water pipe.
- The insulation must seal against the bottom of the condensation water trough.

## RECOMMENDED ALTERNATIVE FOR LEADING OFF CONDENSATION WATER

### Stone caisson

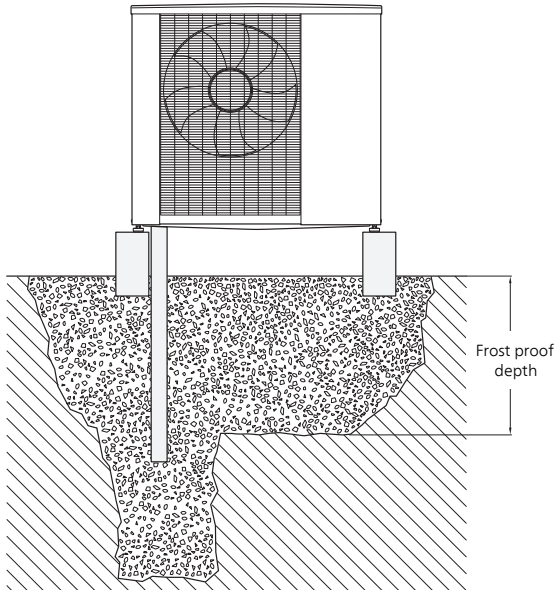

If the house has a cellar the stone caisson must be positioned so that condensation water does not affect the house. Otherwise the stone caisson can be positioned directly under the heat pump.

The outlet of the condensation water pipe must be at frost free depth.

### Drain indoors

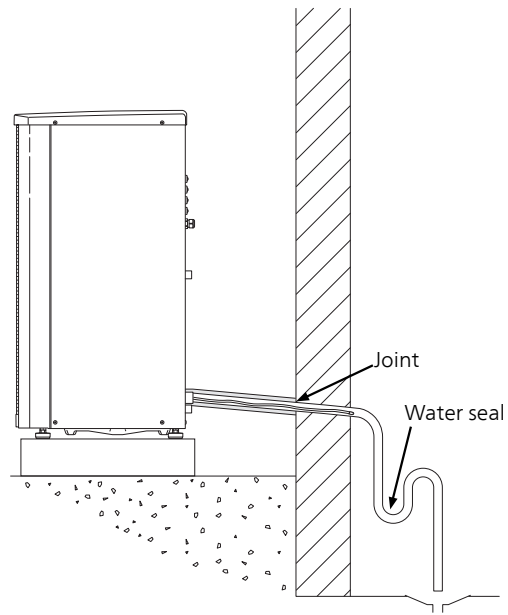

The condensation water is lead to an indoor drain (subject to local rules and regulations).

Route the pipe downward from F2120.

The condensation water pipe must have a water seal to prevent air circulation in the pipe.

KVR 10 spliced as illustrated. Pipe routing inside house not included.

### Gutter drainage

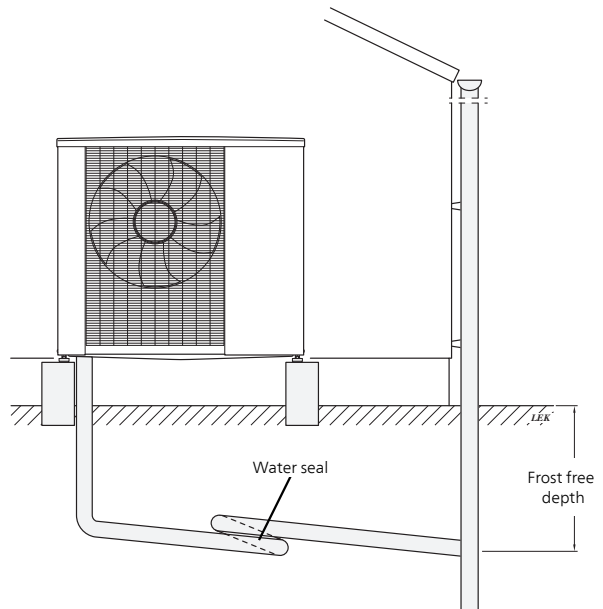

The outlet of the condensation water pipe must be at frost free depth.

Route the pipe downward from F2120.

The condensation water pipe must have a water seal to prevent air circulation in the pipe.



### *Caution*

If none of the recommended alternatives is used good lead off of condensation water must be assured.

# Installation area

The distance between F2120 and the house wall must be at least 350 mm, but not more than 500 mm in locations that are exposed to the wind. The free space above F2120 must be at least 1,000 mm. The free space in front must be at least 1,000 mm for any future servicing.

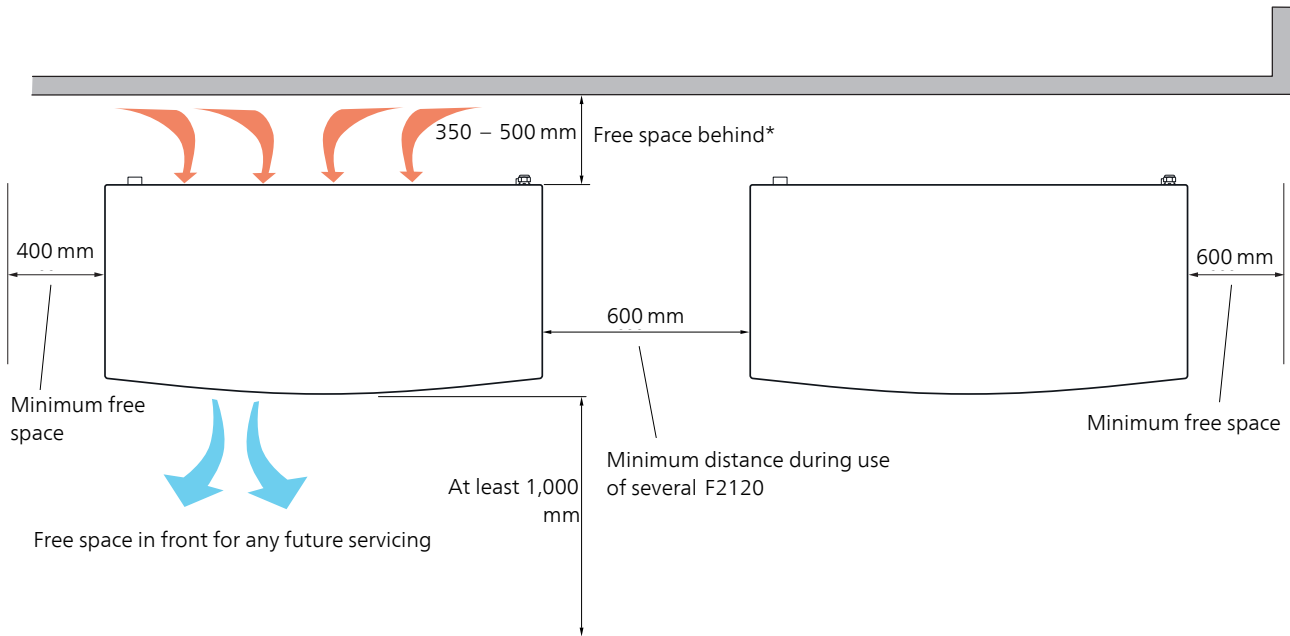

\* The space behind must not exceed 500 mm in locations that are exposed to the wind.

# Supplied components

F2120-8, F2120-12

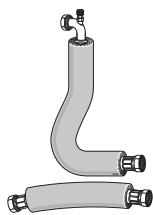

2 x flexible pipes (DN25, G1") with 4 x gaskets.

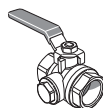

Filterball (G1").

F2120-16, F2120-20

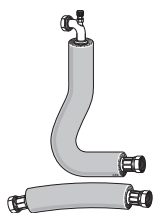

2 x flexible pipes (DN25, G1 1/4") with 4 x gaskets.

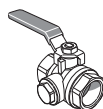

Filterball (G1 1/4").

# Removing the side cover and top panel

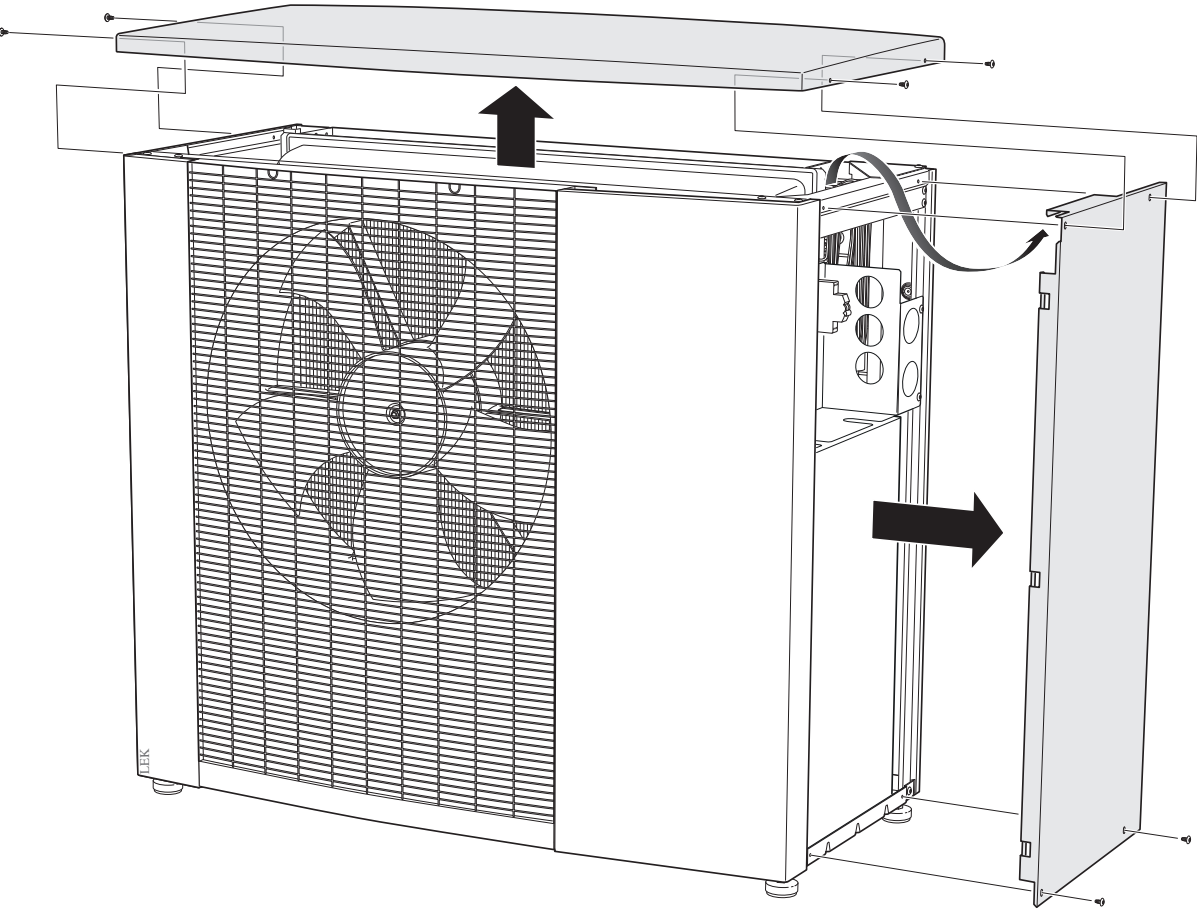



# 3 The heat pump design

## General

F2120 (1x230V)

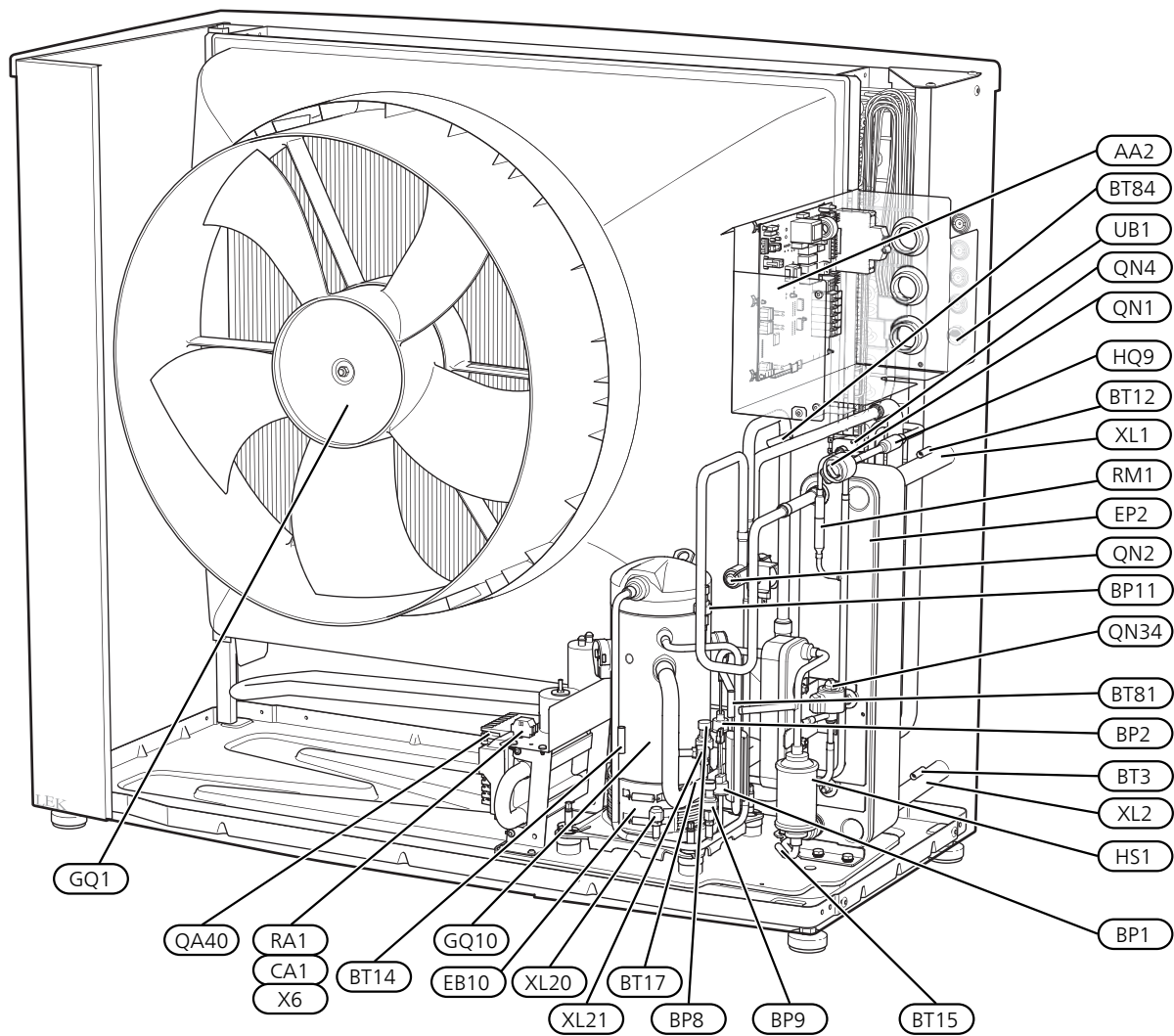

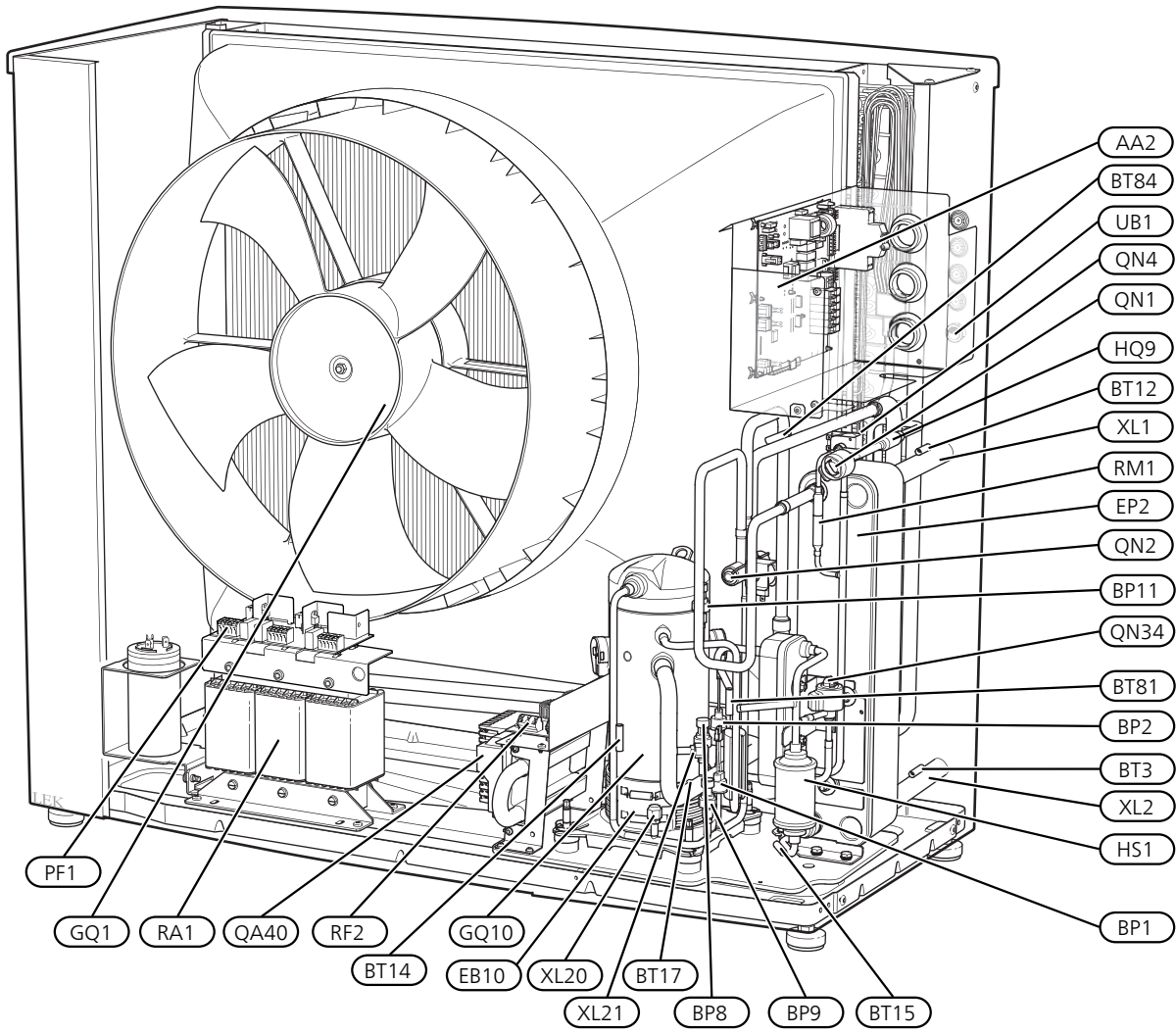

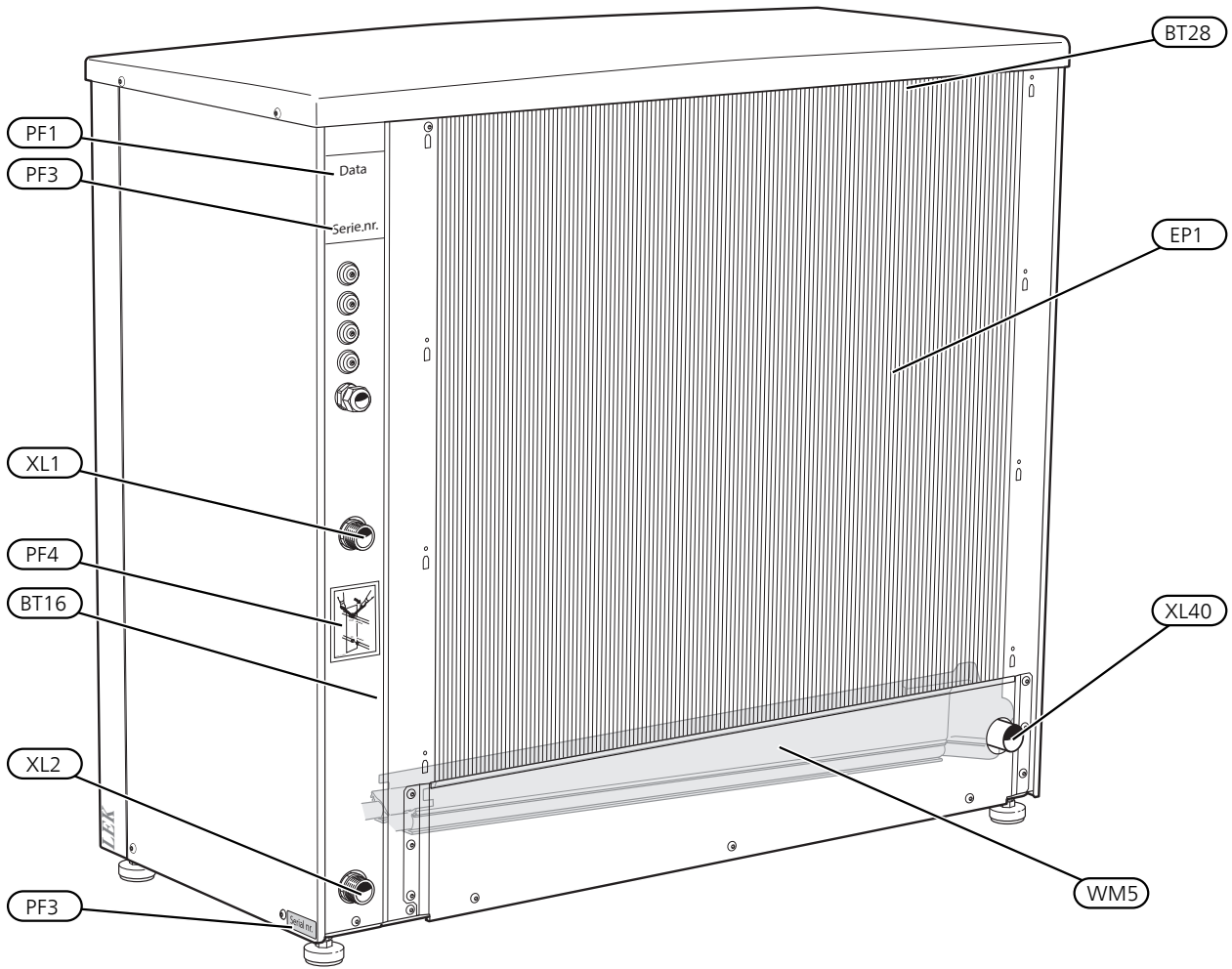

### *Pipe connections*

XL1	Connection, heating medium out of F2120
XL2	Connection, heating medium in to F2120,
XL20	Service connection, high pressure
XL21	Service connection, low pressure
XL40	Connection, drain condensation water trough

### *Sensors etc.*

BP1	High pressure pressostat
BP2	Low pressure pressostat
BP8	Low pressure transmitter
BP9	High pressure sensor
BP11	Pressure sensor, injection
BT3	Temperature sensor, return
BT12	Temperature sensor, condenser supply line
BT14	Temperature sensor, hot gas
BT15	Temperature sensor, fluid pipe
BT16	Temperature sensor, evaporator
BT17	Temperature sensor, suction gas
BT28	Temperature sensor, ambient
BT81	Temperature sensor, injection, EVI compressor
BT84	Temperature sensor, suction gas evaporator

### *Electrical components*

AA2	Base card
CA1	Capacitor (1x230V)
EB10	Compressor heater
GQ1	Fan
PF1	Signal lamp (LED 201)
QA40	Inverter
RA1	Harmonic filter (3x400V)
RA1	Choke (1x230V)
RF2	EMC filter (3x400V)
X6	Terminal block (1x230V)

### *Cooling components*

EP1	Evaporator
EP2	Condenser
GQ10	Compressor
HQ9	Particle filter
HS1	Drying filter
QN1	Expansion valve
QN4	Bypass valve
QN2	4-way valve
QN34	Expansion valve, subcooling
RM1	Non-return valve

### *Miscellaneous*

PF1	Type plate
PF3	Serial number
PF4	Sign, pipe connections
UB1	Cable gland, incoming supply
WM5	Condensation water trough

Designations according to standard EN 81346-2.

# Distribution box

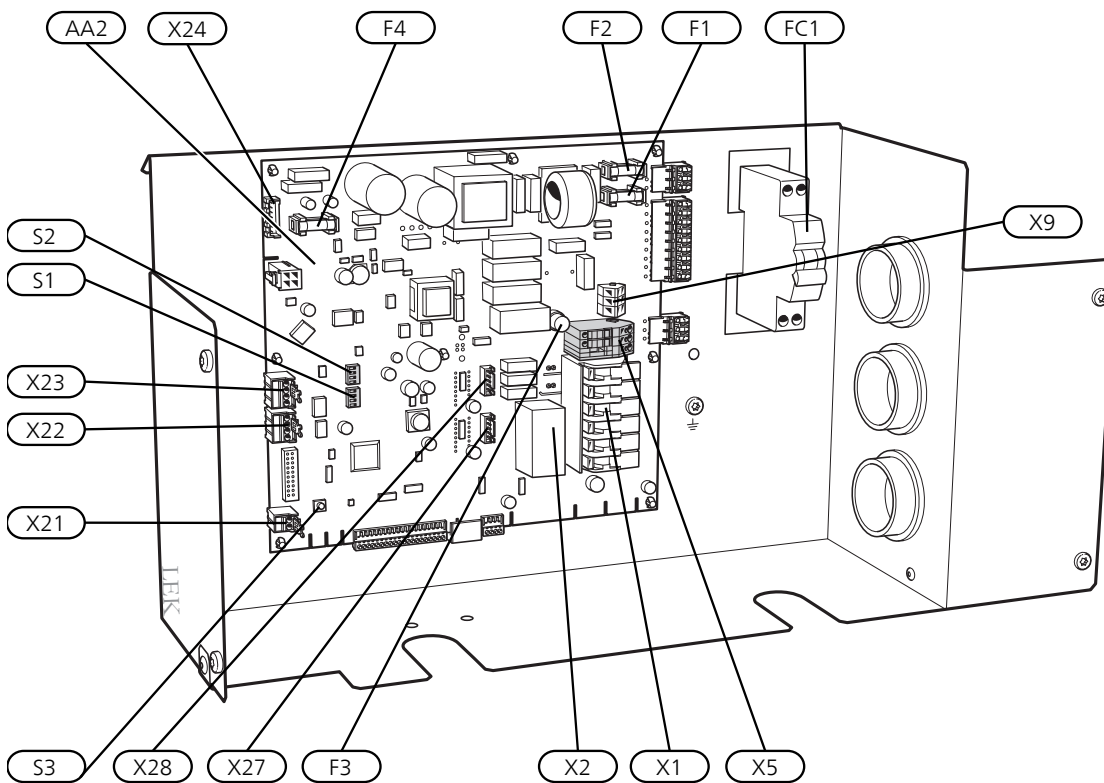

## Electrical components

AA2	Base card
X1	Terminal block, incoming supply
X2	Terminal block, compressor supply
X5	Terminal block, external control voltage
X9	Terminal block, connection KVR
X21	Terminal block, Compressor blocking, Tariff
X22	Terminal block, communications
X23	Terminal block, communications
X24	Terminal block, fan
X27	Terminal block, expansion valve QN1
X28	Terminal block, subcooling QN34
F1	Fuse, operating 230V~
F2	Fuse, operating 230V~
F3	Fuse for external heating cable KVR
F4	Fuse, fan
FC1	Miniature circuit breaker (Replaced with automatic protection (FB1) when installing accessory KVR 10.)
S1	DIP switch, addressing heat pump during multi operation
S2	DIP switch, different options
S3	Reset button

Designations according to standard EN 81346-2.

# 4 Pipe connections

## General

Pipe installation must be carried out in accordance with current norms and directives.

The pipe dimension should not be less than the recommended pipe diameter according to the table. However, each system must be dimensioned individually to manage the recommended system flows.

### MINIMUM SYSTEM FLOWS

The installation must be dimensioned at least to manage the minimum defrosting flow at 100% pump operation, see table.

Air/water heat pump	Minimum flow during defrosting (100% pump speed (l/s))	Minimum recommended pipe dimension (DN)	Minimum recommended pipe dimension (mm)
F2120-8 (1x230V)	0.27	20	22
F2120-8	0.27	20	22
F2120-12 (1x230V)	0.35	25	28
F2120-12	0.35	25	28
F2120-16	0.38	25	28
F2120-20	0.48	32	35



#### NOTE

An undersized system can result in damage to the machine and lead to malfunctions.

F2120 can only operate up to a return temperature of about 55 °C and an outgoing temperature of about 65 °C from the heat pump.

F2120 is not equipped with external shut off valves on the water side; these must be installed to facilitate any future servicing. The return temperature is limited by the return line sensor.

### WATER VOLUMES

Depending on the size of your F2120, an available water volume is required to prevent short operating times and to enable defrosting. For the optimum operation of

F2120, a minimum available water volume of 10 litres multiplied by the size number is recommended. E.g. F2120-12: 10 litres x 12 = 120 litres. This applies individually to heating and cooling systems.



#### NOTE

The pipe work must be flushed before the heat pump is connected, so that any contaminants do not damage the components.

## Pipe coupling heating medium circuit

- The heat pump must be vented by the upper connection (XL1) using the venting nipple on the enclosed flexible hose.
- Install the enclosed particle filter before the inlet, i.e. the lower connection (XL2) on F2120.
- All outdoor pipes must be thermally insulated with at least 19 mm thick pipe insulation.
- Install shutoff and drain valves so that F2120 can be emptied in the event of prolonged power failures.
- The supplied flexible hoses act as vibration dampers. The flexible pipes are fitted so an elbow is created, thus acting as vibration damping.

### CHARGE PUMP

The charge pump (not included in the product) is powered and controlled from the indoor module/control module. It has a built-in anti-freezing function and must therefore not be switched off when there is a risk of freezing.

At temperatures below +2 °C the charge pump runs periodically, to prevent the water from freezing in the charge circuit. The function also protects against excess temperatures in the charge circuit.

# Pressure drop, heating medium side

F2120-8, -12, -16, -20

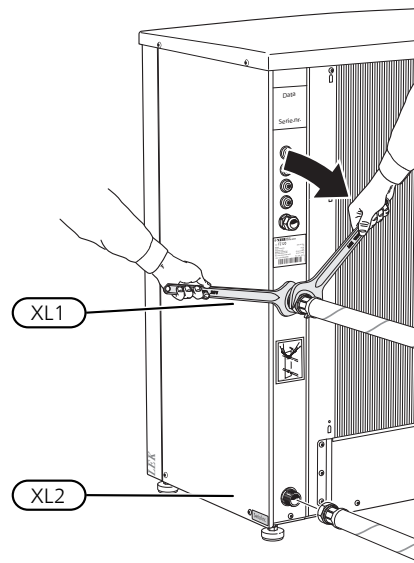
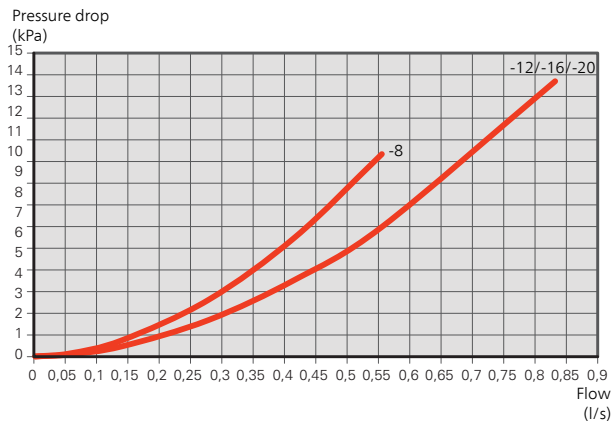

# Heat insulation

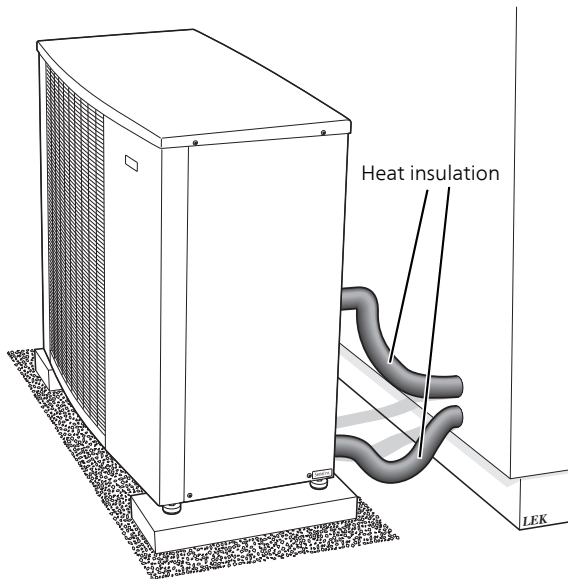

# 5 Electrical connections

## General

- The heat pump must not be connected without the permission of the electricity supplier and must be connected under the supervision of a qualified electrician.
- If F2120 is fused with a miniature circuit breaker, it must have at least motor characteristic "C". For MCB size see "Technical Specifications".
- F2120 does not include an omnipolar circuit breaker on the incoming power supply. The heat pump's supply cable must be connected to a circuit breaker with at least a 3 mm breaking gap. When the building is equipped with an earth-fault breaker, the heat pump should be equipped with a separate one. The earth-fault breaker should have a nominal tripping current of no more than 30 mA. Incoming supply must be 400V 3N~ 50Hz via electrical distribution units with fuses.  
For 230V~ 50Hz, the incoming supply must be 230V~ 50Hz via distribution box with fuses.
- If an insulation test is to be carried out in the building, disconnect the heat pump.
- If the control is to be supplied separately from other components in the heat pump (e.g. for tariff connection), a separate operating cable must be connected to terminal block (X5).
- The routing of cables for heavy current and signals should be made out through the cable glands on the heat pump's right-hand side, seen from the front.
- The communication cable must be a three core, screened cable and be connected between F2120 terminal block X22 and the indoor module/control module.
- Connect the charge pump to the indoor module/control module. See where the charge pump must be connected in the installation manual for your indoor module/control module.



### NOTE

Electrical installation and any servicing must be carried out under the supervision of a qualified electrician. Disconnect the current with the circuit breaker before carrying out any servicing. Electrical installation and wiring must be carried out in accordance with the national stipulations in force.



### NOTE

Check the connections, main voltage and phase voltage before starting the machine to prevent damage to the air/water heat pump's electronics.



### NOTE

The live external control must be taken into consideration when connecting.



### NOTE

If the supply cable is damaged, only NIBE, its service representative or similar authorised person may replace it to prevent any danger and damage.



# Accessibility, electrical connection

## REMOVING THE SIDE COVER

Unscrew the screws and lift off the cover.

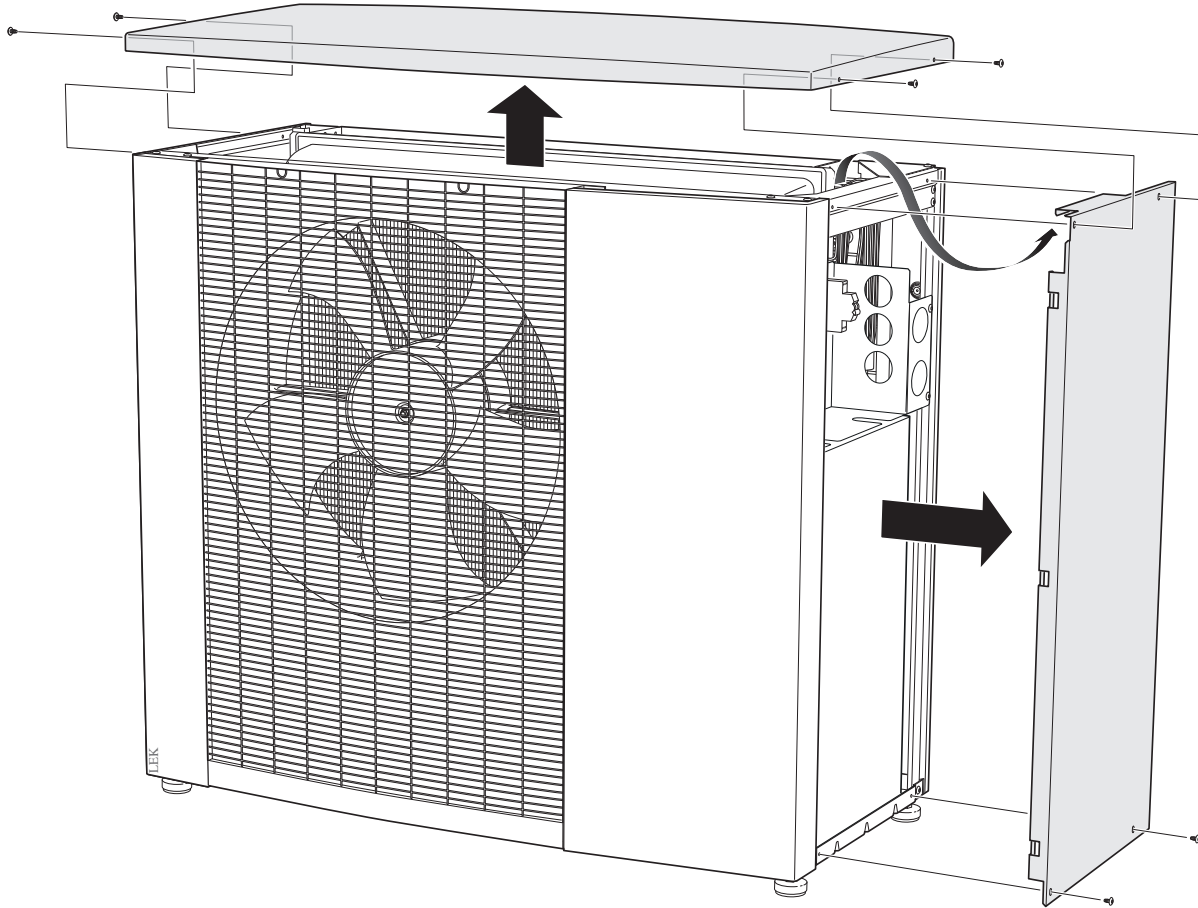

# Configuration using DIP switch

The communication address for F2120 to the indoor module / control module is selected on the base board (AA2). DIP switch S1 is used for configuration of address and functions. For cascade operation with SMO for example, addressing is required. F2120 has the address **1** as standard. In a cascade connection all F2120 must have a unique address. The address is coded in binary.



## NOTE

Only change the DIP switches position when the product is not powered.

DIP S1 position (1 / 2 / 3)	Slave	Address (com)	Default setting
off / off / off	Slave 1	01	OFF
on / off / off	Slave 2	02	OFF
off / on / off	Slave 3	03	OFF
on / on / off	Slave 4	04	OFF
off / off / on	Slave 5	05	OFF
on / off / on	Slave 6	06	OFF
off / on / on	Slave 7	07	OFF
on / on / on	Slave 8	08	OFF

DIP S1 position	Setting	Function	Default setting
4	ON	Permits cooling	OFF

DIP S2 position	Setting	Default setting
1	OFF	OFF
2	OFF	OFF
3	OFF	OFF
4	OFF	OFF

Switch S3 is the reset button that restarts control.



## Caution

DIP S1 position 4 must be changed to ON in order to run cooling

# Connections



## Caution

To prevent interference, unscreened communication and/or sensor cables to external connections must not be laid closer than 20 cm from high voltage cables.

## POWER CONNECTION

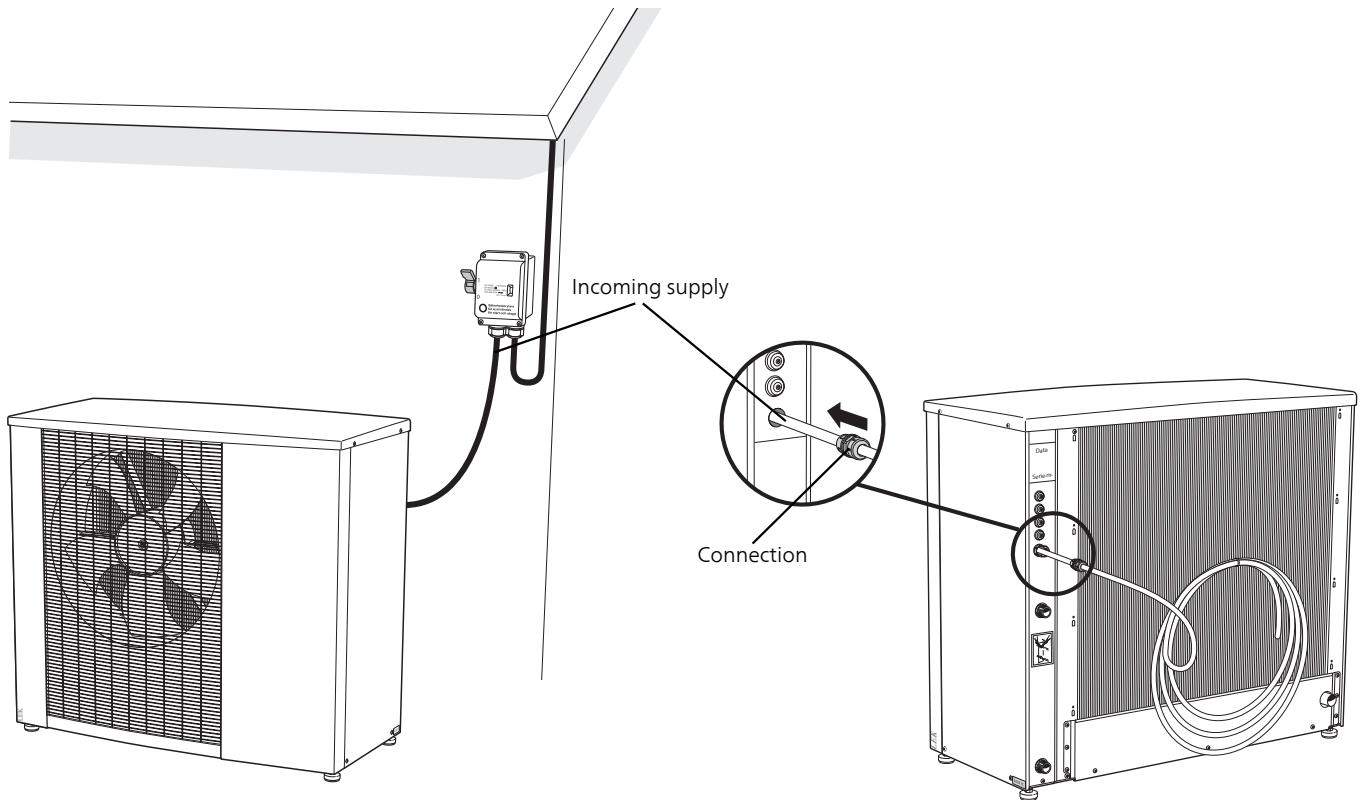

Incoming supply cable is enclosed and factory connected to terminal block X1. Outside the heat pump there is approx. 1.8 m of cable available.

At installation, install the screwed connection on the rear of the heat pump. The part of the screwed joint that tensions the cable must be tightened to a tightening torque above 3.5Nm.

## CONNECTING EXTERNAL CONTROL VOLTAGE



### NOTE

Mark up any junction boxes with warnings for external voltage.

When connecting external control voltage, remove the bridges from terminal block X5 (see image).

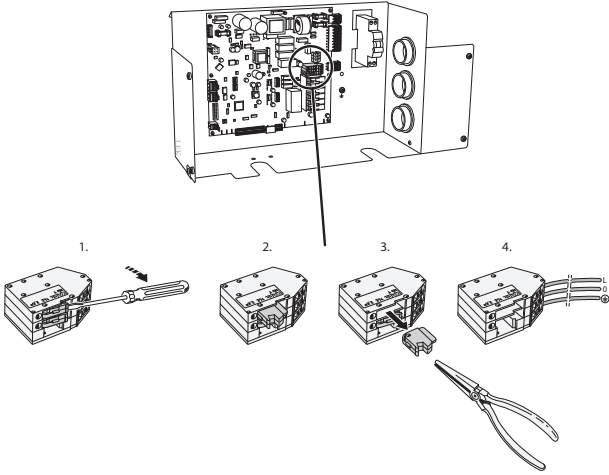

Connect external control voltage (230V~ 50Hz) to terminal block X5:L, X5:N and X5:PE (as illustrated).

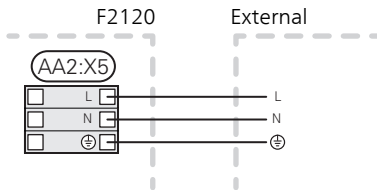

If external control voltage is used during tariff control, connect a closing contact to terminal X21:1 and X21:2 (compressor blocking) to prevent an alarm.

Compressor blocking must be performed either on the indoor module/control module or on the air/water heat pump, not on both at the same time.

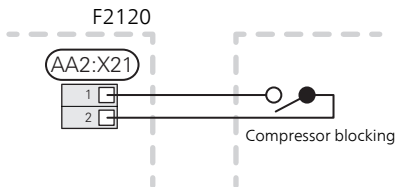

## EXTERNAL HEATING CABLE IN CONDENSATION WATER PIPE (KVR 10)

F2120 is equipped with a plinth for external heating cable (EB14, not enclosed). The connection is fused with 250 mA (F3) at the factory. If another heating cable is to be used the fuse must be replaced with a suitable one.

Length (m)	Total output (W)	Fuse (F3)	Part No.
1	15	T100mA/250V	718085
3	45	T250mA/250V	518900*
6	90	T500mA/250V	718086

\* Fitted at the factory.

Replace the MCB (FC1) for automatic protection (FB1) when installing KVR 10 if there is no external automatic protection for the installation. Automatic protection (FB1) is available as enclosed component for KVR 10.

Connect external heating cable (EB14) to terminal block X9:L and X9:N. If there is a ground cable connect it to X9:PE. See following image and read further in the installer manual for KVR 10.

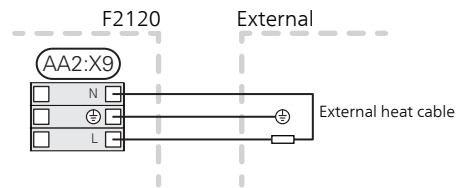

### NOTE

The pipe must be able to withstand the heat from the heating cable.

To ensure this function the accessory KVR 10 should be used.

## Cable routing

The following image shows recommended cable routing from the distribution box to the condensation water trough on the inside of F2120. Transition between the electrical cable and the heating cable must occur after the lead-in to the condensation water trough. The distance between the distribution box and the lead-in to the condensation water trough is approx. 1,600 mm.

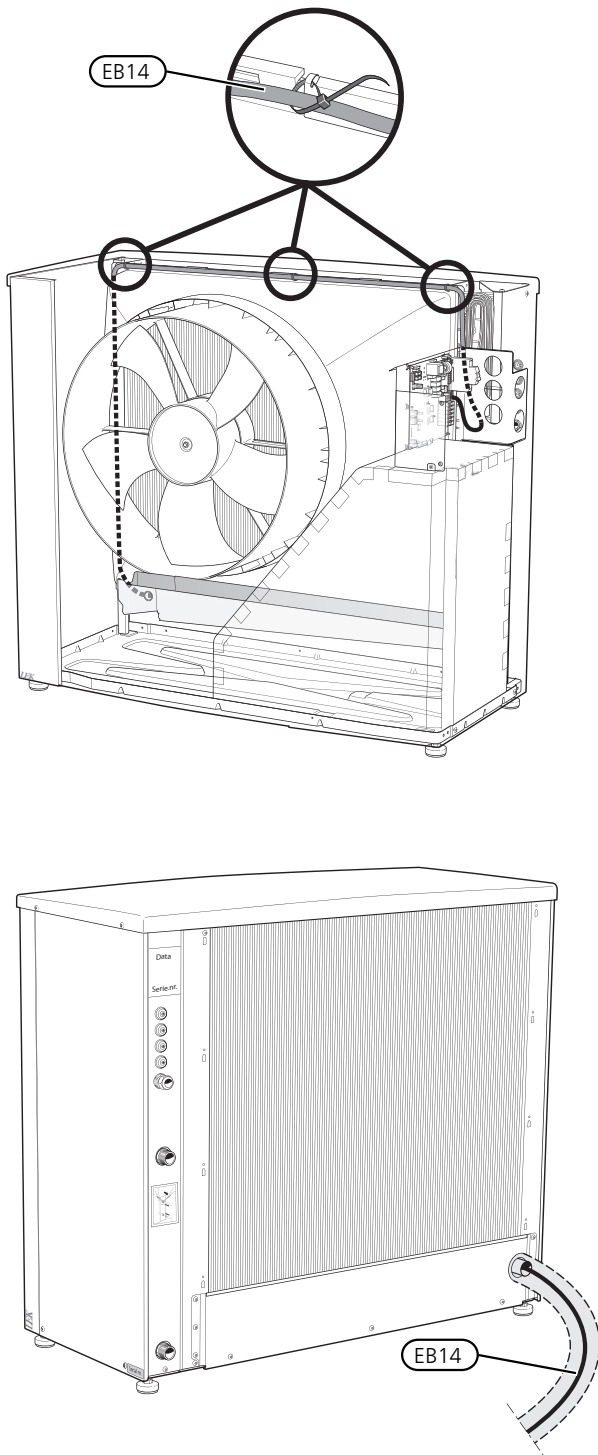

# Optional connections

## COMMUNICATION

F2120 communicates with NIBE indoor modules/control modules by connecting a three-core, screened cable (max area 0.75 mm<sup>2</sup>) to terminal block X22:1–4, as shown in the following image.

In the event of cascade connection, join terminal block X23 with the next heat pump's terminal block X22.

<i>Indoor module / Control module</i>	<i>Software version</i>
VVM 310 / VVM 500	v7568R4
VVM 320	v7530R5
SMO 20	v7607R3
SMO 40	v7635R5
VVM 225	v8212R3
VVM S320	All versions
SMO S40	All versions

### *Software version*

In order for F2120 to be able to communicate with indoor module (VVM) / control module (SMO) the software version must be according to the table.

Disconnect the connections in F2120

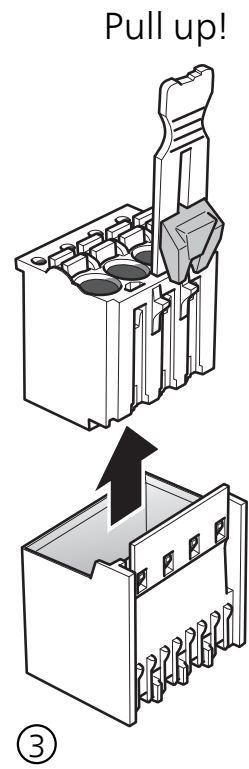
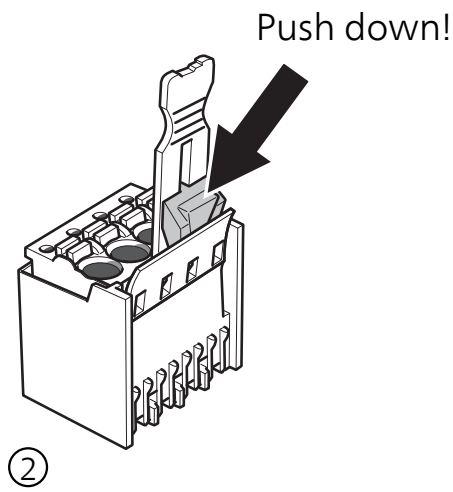
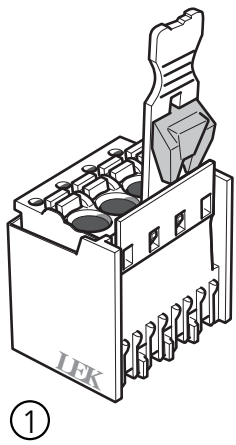
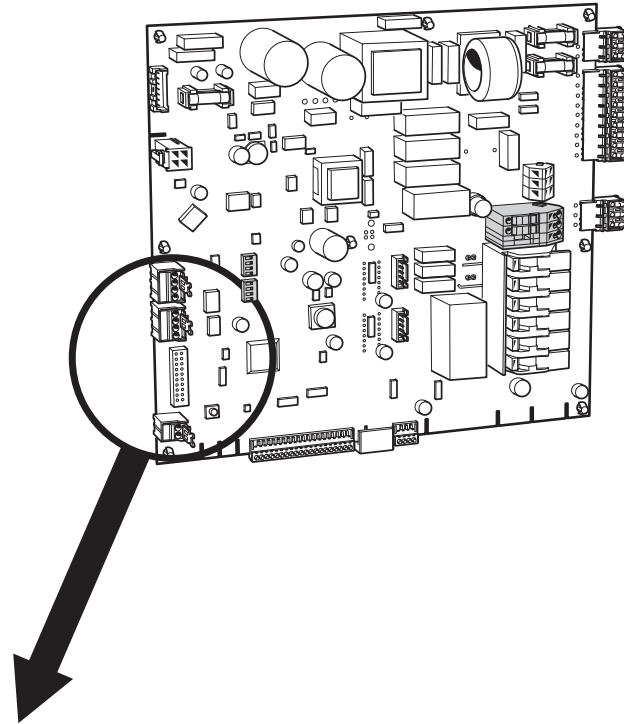

## VVM S

Indoor module

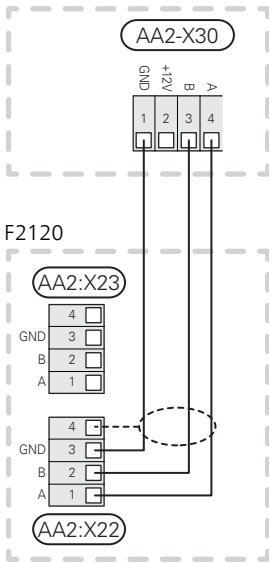

## VVM

Indoor module

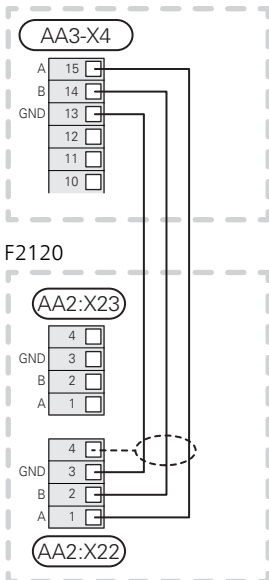

## SMO S40

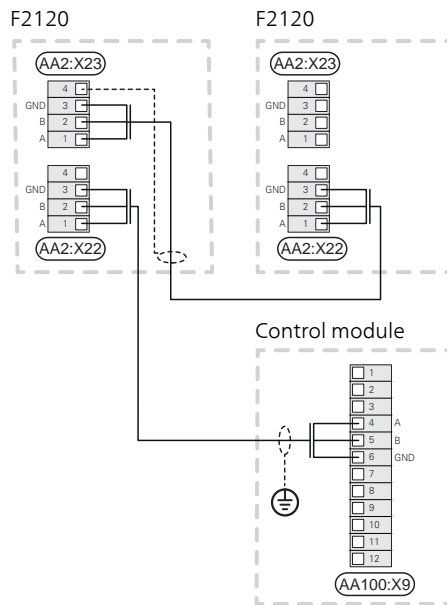
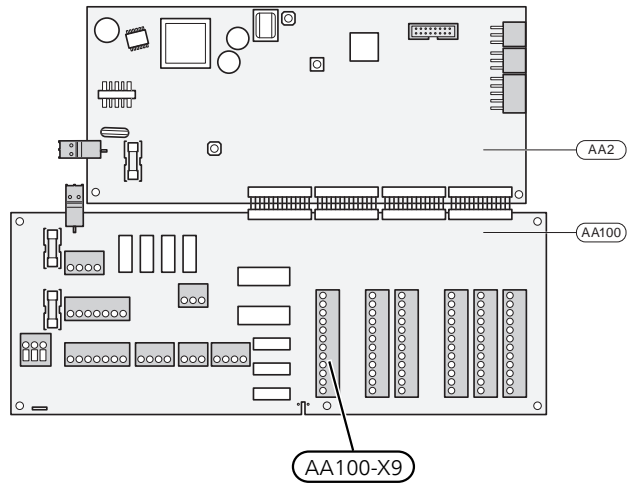



SMO 20

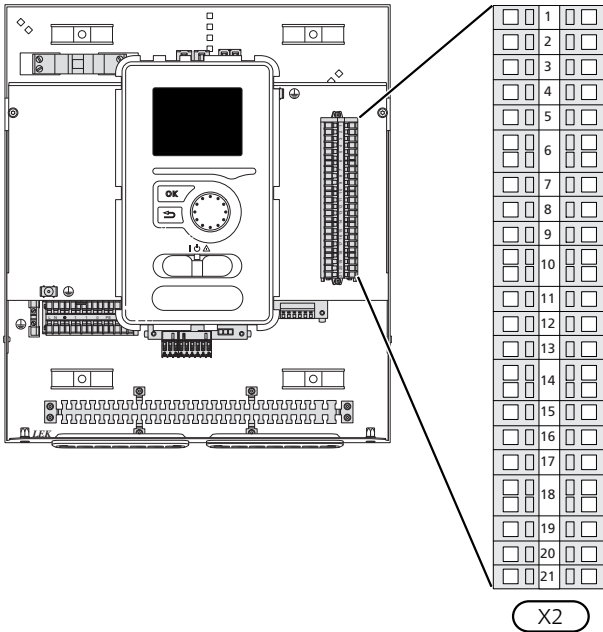

F2120

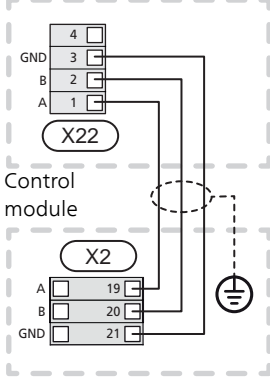

SMO 40

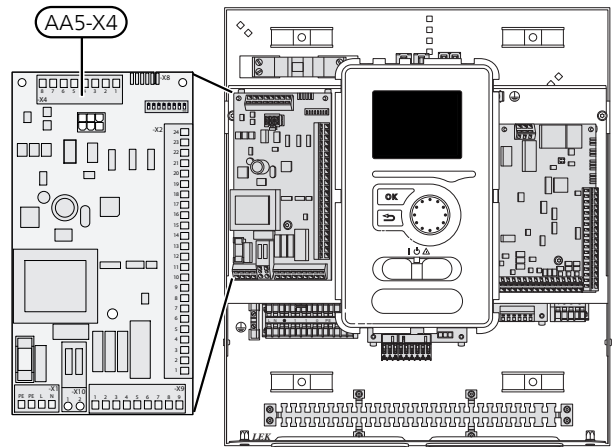

F2120

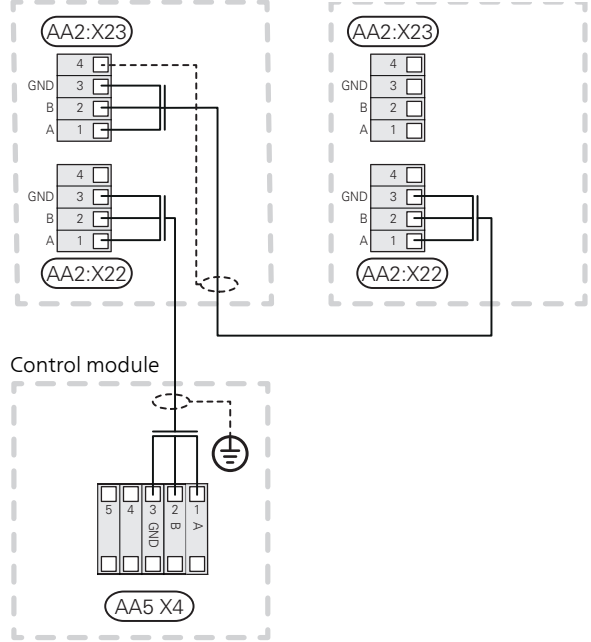

For connection of indoor module/control module, see relevant manual on nibe.eu.

## Connecting accessories

Instructions for connecting accessories can be found in the installation instructions provided for the respective accessory. See section "Accessories" for a list of the accessories that can be used with F2120.

# 6 Commissioning and adjusting

## Preparations

- Check that the pipe system is prepared.
- Check the pipe system for leaks.
- Check that the electrical installation is prepared.
- Check that the electrical supply is connected so that the compressor heater (EB10) can start warming up the compressor, if necessary.
- The compressor heater (EB10) must have been active for at least 3 hours before compressor operation can be initiated. This is done by connecting control voltage. F2120 permits compressor start after the compressor has been warmed up. This can take up to 3 hours.

## Balance temperature

The balance temperature is the outdoor temperature when the heat pump's stated output is equal to the building's output requirement. This means that the heat pump covers the whole building's output requirement down to this temperature.

## Filling and venting

Filling and venting the heating medium system.

1. Fill the heating medium system to the necessary pressure.
2. F2120 is fitted with automatic venting and does not need to be vented.

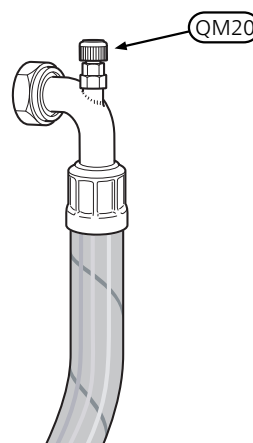

# Start-up and inspection

1. Communication cable, terminal block (X22:1-4) must be connected.
2. If cooling operation with F2120 is wanted, DIP switch S1 position 4 must be changed according to the description in section 26.
3. Turn the isolator switch on.
4. Ensure that the F2120 is connected to the power source.
5. Check that fuse (FC1) is on.
6. Reinstall the removed panels and cover.
7. After the power to F2120 has been switched on and there is a compressor demand from the indoor module/control module, the compressor starts once it has warmed up, after max 180 minutes.  
The length of this time delay depends on whether the compressor has been warmed up previously. See the instructions in section "Preparations".
8. Adjust the charge flow according to size. Also see section "Adjustment, charge flow".
9. Adjust menu settings via the indoor module/control module as necessary.
10. Fill in the commissioning report in the user manual.
11. Remove the protective film from the cover on F2120.



## NOTE

The external control must be taken into consideration when connecting.

## Readjusting, heating medium side

Air is initially released from the hot water and venting may be necessary. If bubbling sounds can be heard from the heat pump, the circulation pump and radiators the entire system will require further venting. When the system is stable (correct pressure and all air eliminated) the automatic heating control system can be set as required.

# Adjustment, charge flow

For correct function of the heat pump over the entire year, the charge flow must be correctly adjusted.

If an NIBE indoor module VVM or accessory controlled charge pump is used for the control module SMO, the control tries to maintain an optimal flow across the heat pump.

Adjustment may be required, especially for charging a separate water heater. It is therefore recommended to have the option of adjusting the flow across the water heater using a trim valve.

1. Recommendation if there is insufficient hot water and information message "high condenser out" during hot water charging: increase the flow
2. Recommendation if there is insufficient hot water and information message "high condenser in" during hot water charging: reduce the flow

# 7 Control - Introduction

## General

F2120 is equipped with an internal electronic controller that handles all functions necessary for operation of the heat pump, e. g. defrosting, stop at max/min temperature, connection of the compressor heater, and protective functions during operation.

Temperatures, number of starts and run time, are read off in the indoor module/control module.

The integrated control shows information via status-LEDs and can be used during servicing.

Under normal operating conditions the home owner does not need to have access to the controller.

F2120 communicates with the NIBE indoor module/control module, which means that all settings and measurement values from F2120 are adjusted and read off on the indoor module/control module.

## LED status

The base board (AA2) has six status LEDs for easy control and fault tracing.

LED	State	Explanation
PWR (green)	Not lit	Control board without power
	Continuous light	Control board power on
CPU (green)	Not lit	CPU without power
	Flashes	CPU running
	Continuous light	CPU running incorrectly
EXT COM (green)	Not lit	No communication with indoor module/control module
	Flashes	Communication with indoor module/control module
INT COM (green)	Not lit	No communication with inverter
	Flashes	Communication with inverter

LED	State	Explanation
DEFROST (green)	Not lit	No defrosting or protection active
	Flashes	Some protection is active
	Continuous light	Defrosting in progress
ERROR (red)	Not lit	No errors
	Flashes	Infoalarm (temporary), active
	Continuous light	Continuous alarm, active
K1, K2, K3, K4, K5	Not lit	Relay in de-energised position
	Continuous light	Relay engaged
N-RELAY		No function
COMPR. ON		No function

## HARMONIC FILTER (RA1)

Harmonic filter (RA1) has one status LED for easy control and troubleshooting.

When the compressor is in operation, LED 201 is lit with a steady light.

LED	State	Explanation
LED 201 (red)	Not lit	Capacitor disconnected
	Continuous light	Capacitor connected

# Master control

To control F2120, a NIBE indoor module/control module is required, which calls upon F2120 according to demand. All settings for F2120 are made via the indoor module/control module. It also shows the status and sensor values from F2120.

<i>Description</i>	<i>Value</i>	<i>Parameter space</i>	<i>Unit</i>
Cut-out value activation passive defrosting	4	4 – 14	°C
Start temperature BT16 to calculate index	-3	-5 – 5	°C
Permit fan de-icing	No	Yes / No	(1 / 0)
Permit silent mode	No	Yes / No	(1 / 0)
Permit defrost more often	No	Yes / No	(1 / 0)

# Control conditions

## CONTROL CONDITIONS DEFROSTING

- If the temperature on the evaporation sensor (BT16) is below the start temperature for the defrosting function, F2120 counts the time to "active defrosting" each minute that the compressor is running, to create a defrosting requirement.
- Time until "active defrosting" is shown in minutes on the indoor module / control module. Defrosting starts when this value is 0 minutes.
- "Passive defrosting" is started, if the compressor requirement has been fulfilled, at the same time as there is a defrosting requirement and the outdoor temperature (BT28) is greater than 4 °C.
- Defrosting occurs actively (with compressor on and fan off) or passively (with compressor off and fan on).
- If the evaporator is too cold, a "safety defrost" starts. This defrosting can start earlier than the normal defrosting. If the safety defrosting occurs ten times in a row, the evaporator (EP1) on F2120 must be checked, which is indicated by an alarm.
- If "de-icing fan" is activated in the indoor module/control module, "de-icing fan" starts at the next "active defrosting". "De-icing fan" removes the build-up of ice on the fan blades and the front fan grille.

### *Active defrosting:*

1. The four way valve shifts to defrosting.
2. The fan stops and the compressor continues to run.
3. When defrosting is complete, the four-way valve switches back to heating operation. The compressor speed is locked for a short period.
4. The ambient temperature is locked and the high return temperature alarm is blocked for two minutes after defrosting.

### *Passive defrosting:*

1. If there is no compressor demand, passive defrosting can start.
2. The four way valve does not shift.
3. Fan runs at high speed.
4. If there is a compressor demand, passive defrosting stops and the compressor starts.
5. When passive defrosting is complete, the fan stops.
6. The ambient temperature is locked and the high return temperature alarm is blocked for two minutes after defrosting.

*There are several possible reasons for an active defrosting to end:*

1. If the temperature of the evaporator sensor has reached its stop value (normal stop).
2. When defrosting has gone on for longer than 15 minutes. This may be due to too little energy in the heat source, too strong a wind effect on the evaporator and/or that the sensor on the evaporator is not correct and therefore displays too low a temperature (at cold outdoor air).
3. When the temperature on the return line sensor, BT3, falls below 10 °C.
4. If the temperature of the evaporator (BP8) falls below its lowest permitted value. After failing to defrost ten times, F2120 must be checked. This is indicated by an alarm.

# Control - Heat pump EB101

## VVM S /SMO S

These settings are made on the display on the indoor module/control module.

### *Menu 7.3.2 - Installed heat pump*

Here, you make specific settings for the installed heat pump.

#### *Cooling permitted*

Setting range: on/off

#### *Silent mode permitted*

Setting range: on/off

#### *Max. frequency 1*

Setting range: 25 – 120 Hz

#### *Max. frequency 2*

Setting range: 25 – 120 Hz

#### *Compressor phase*

Setting range: L1, L2, L3

#### *Detect compressor phase*

Here, you can choose to start compressor phase detection.

#### *Current limit*

Setting range: on/off

#### *Max. current*

Setting range: 6 – 32 A

#### *Stop temperature compressor*

Setting range -20 – -2 °C

#### *blockFreq 1*

Setting range: on/off

#### *From frequency*

Setting range: 25 – 117 Hz

#### *To frequency*

Setting range: 28 – 120 Hz

#### *blockFreq 2*

Setting range: on/off

#### *From frequency*

Setting range: 25 – 117 Hz

#### *To frequency*

Setting range: 28 – 120 Hz

## *Menu 4.11.3 - Fan de-icing*

### *Fan de-icing*

Set whether the "de-icing fan" must be deactivated during the next "active defrosting" here. This can be activated if ice / snow sticks to the fan, grille or fan cone, which is noticed because of abnormal fan noise from F2120.

It is possible to set recurring de-icing. Every tenth defrosting will then be "Fan de-icing". (This can increase your annual energy consumption.)

"De-icing fan" means that the fan, grille or fan cone is heated using hot air from the exchanger (EP1).



## VVM / SMO

These settings are made on the display on the indoor module/control module.

### *Menu 5.11.1.1 - heat pump*

#### *Silent mode permitted*

Here, you set whether silent mode is to be activated for the heat pump. Note that it is now possible to schedule when silent mode will be active.

The function should only be used for limited periods, because F2120 possibly may not reach its dimensioned output.

#### *Detect compressor phase*

This shows on which the phase the heat pump has detected whether you have F2120 230V~50Hz. Phase detection normally occurs automatically in connection with start-up of the indoor module/control module. This setting can be changed manually.

#### *Current limit*

Here, you set whether the current limiting function is to be activated for the heat pump, if you have F2120 230V~50Hz. In the case of active function, you can limit the value of the maximum current.

Setting range: 6 – 32 A

Factory setting: 32 A

#### *blockFreq 1*

Select a frequency range within which the heat pump may work here. This function can only be used if certain compressor speeds cause noise disturbance in the house.

#### *blockFreq 2*

Select a frequency range within which the heat pump may work here.

## *Defrosting*

Here you can change the settings that affect the defrost function.

### *Start temperature for defrost function*

Here you can set at which temperature (BT16) the defrost function is to start. The value must only be changed in consultation with your installer.

Setting range: -5 – 5 °C

Factory setting: -3 °C

### *Cut-out value activation passive defrosting*

Here you can set at which temperature (BT28) passive defrosting is to be activated. During passive defrosting, the ice is melted by the energy from the ambient air. The fan is active during passive defrosting. The value must only be changed in consultation with your installer.

Setting range: 2 – 10 °C

Factory setting: 4 °C

### *Defrost more often*

Here you activate whether defrosting is to occur more frequently than normal. The selection can be made again if the heat pump receives an alarm due to build-up of ice during operation caused by snow, for example.

### *Start manual defrosting*

Here you can manually start an "active defrosting", in the event that the function must be tested for servicing or if operation is necessary. This can be motivated together with "de-icing fan".

## *Menu 4.9.7 - tools*

### *Fan de-icing*

Set whether the "de-icing fan" must be deactivated during the next "active defrosting" here. This can be activated if ice / snow sticks to the fan, grille or fan cone, which is noticed because of abnormal fan noise from F2120.

It is possible to set recurring de-icing. Every tenth defrosting will then be "Fan de-icing". (This can increase your annual energy consumption.)

"De-icing fan" means that the fan, grille or fan cone is heated using hot air from the exchanger (EP1).

# 8 Disturbances in comfort

## Troubleshooting



### NOTE

In the event of action to rectify malfunctions that require work within screwed hatches, the incoming supply electricity must be isolated at the safety switch by or under the supervision of a qualified electrician.



### Caution

Alarms are acknowledged on the indoor module / control module (VVM / SMO).

The following tips can be used to rectify comfort disruption:

### BASIC ACTIONS

Start by checking any alarm messages in the info menu on the indoor module (VVM) / control module (SMO). Follow the instructions on the display on the indoor module (VVM) / control module (SMO).

#### *F2120 not in operation*

F2120 communicates all alarms to the indoor module/control module (VVM / SMO).

- Ensure that the F2120 is connected to the power source and that compressor operation is required.
- Check the indoor module/control module (VVM / SMO). See section "Disturbances in comfort" in the Installer Manual for the indoor module/control module (VVM / SMO).

#### *F2120 does not communicate*

- Check that F2120 is correctly installed in the indoor module (VVM) or the control module (SMO).
- Check that the communication cable is correctly connected and working.

### LOW HOT WATER TEMPERATURE OR A LACK OF HOT WATER



### Caution

The hot water is always set on the indoor module (VVM) or the control module (SMO).

This part of the fault-tracing chapter only applies if the heat pump is docked to the hot water heater.

- Large hot water consumption.
  - Wait until the hot water has heated up.
- The hot water settings are adjusted on the display on the indoor module / control module.
  - See the manual for the indoor module or control module.
- Clogged particle filter.
  - Switch off the system. Check and clean the particle filter.

### LOW ROOM TEMPERATURE

- Closed thermostats in several rooms.
  - Set the thermostats to max in as many rooms as possible.
- Incorrect settings in indoor module or control module.
  - See the manual for the indoor module / control module (VVM / SMO).
- Incorrect flow across the heat pump.
  - Check whether alarm "high condenser in" or "high condenser out" are information messages. Follow the instructions for adjusting charge flow.
- Air-filled radiators/underfloor heating coils.
  - Bleed the system.

## HIGH ROOM TEMPERATURE

- Incorrect settings in indoor module or control module.
  - See the manual for the indoor module or control module.

## ICE BUILD-UP IN THE FAN, GRILLE AND/OR FAN CONE ON THE OUTDOOR MODULE

- Activate "fan de-icing" in the indoor module/control module.
- Check that the air flow across the evaporator is correct.

## LARGE AMOUNT OF WATER BELOW F2120

- KVR 10 is required.
- If KVR 10 is installed, check that the water drainage flows freely.

## SENSOR PLACEMENT

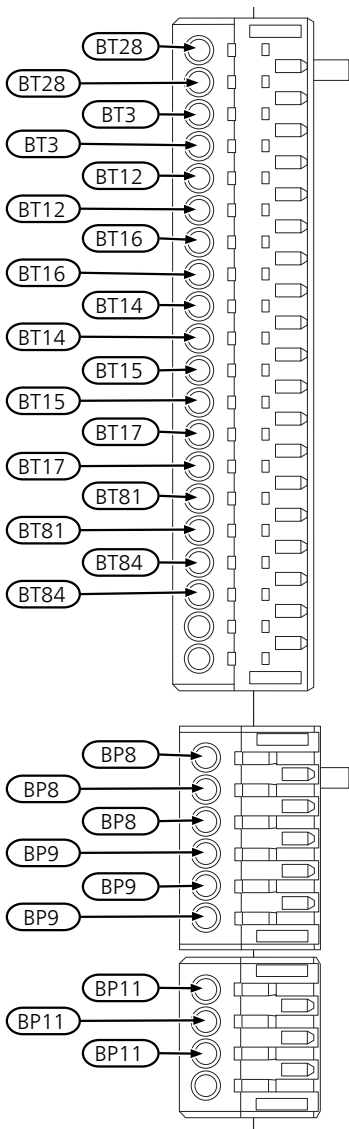
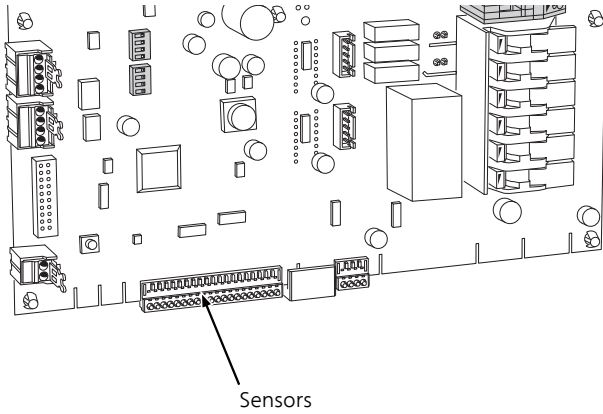

- BP8 Low pressure transmitter
- BP9 High pressure sensor
- BP11 Pressure sensor, injection
- BT3 Temperature sensor, return
- BT12 Temperature sensor, condenser supply line
- BT14 Temperature sensor, hot gas
- BT15 Temperature sensor, fluid pipe
- BT16 Temperature sensor, evaporator
- BT17 Temperature sensor, suction gas
- BT28 Temperature sensor, ambient
- BT81 Temperature sensor, injection, EVI compressor
- BT84 Temperature sensor, suction gas, evaporator

*Data for temperature sensor return line (BT3), condenser supply (BT12), fluid pipe (BT15) and injection (BT81)*

Temperature (°C)	Resistance (kOhm)	Voltage (VDC)
-40	351.0	3.256
-35	251.6	3.240
-30	182.5	3.218
-25	133.8	3.189
-20	99.22	3.150
-15	74.32	3.105
-10	56.20	3.047
-5	42.89	2.976
0	33.02	2.889
5	25.61	2.789
10	20.02	2.673
15	15.77	2.541
20	12.51	2.399
25	10.00	2.245
30	8.045	2.083
35	6.514	1.916
40	5.306	1.752
45	4.348	1.587
50	3.583	1.426
55	2.968	1.278
60	2.467	1.136
65	2.068	1.007
70	1.739	0.891
75	1.469	0.785
80	1.246	0.691
85	1.061	0.607
90	0.908	0.533
95	0.779	0.469
100	0.672	0.414

Data for hot gas sensor (BT14)

Temperature (°C)	Resistance (kOhm)	Voltage (V)
40	118.7	4.81
45	96.13	4.77
50	78.30	4.72
55	64.11	4.66
60	52.76	4.59
65	43.64	4.51
70	36.26	4.43
75	30.27	4.33
80	25.38	4.22
85	21.37	4.10
90	18.07	3.97
95	15.33	3.83
100	13.06	3.68
105	11.17	3.52
110	9.59	3.36
115	8.26	3.19
120	7.13	3.01
125	6.18	2.84
130	5.37	2.67
135	4.69	2.50
140	4.10	2.33

Data for evaporator sensor (BT16), ambient sensor (BT28), suction gas sensor (BT17) and suction gas, evaporator (BT84)

Temperature (°C)	Resistance (kOhm)	Voltage (VDC)
-50	77.58	4.71
-45	57.69	4.62
-40	43.34	4.51
-35	32.87	4.37
-30	25.17	4.21
-25	19.43	4.03
-20	15.13	3.82
-15	11.88	3.58
-10	9.392	3.33
-5	7.481	3.07
0	6.000	2.80
5	4.844	2.54
10	3.935	2.28
15	3.217	2.03
20	2.644	1.80
25	2.186	1.59
30	1.817	1.39
35	1.518	1.22
40	1.274	1.07
45	1.075	0.93
50	0.911	0.81
55	0.775	0.71
60	0.662	0.62
65	0.568	0.54
70	0.490	0.47
75	0.4233	0.41
80	0.367	0.36
85	0.320	0.32
90	0.280	0.28
95	0.245	0.25
100	0.216	0.22

# 9 Alarm list

<i>Alarms VVM/SMO (F2120)</i>	<i>Alarms S-series</i>	<i>Alarm text on the display</i>	<i>Description existing alarm</i>	<i>May be due to</i>
156 (80)	212	Low lp cooling	5 repeated alarms for low low-pressure within 4 hours.	Poor flow. Significant wind effect.
224 (182)	233	Fan alarm from heat pump	5 unsuccessful start attempt.	Fan blocked or not connected.
225 (8)	234	Exchange Sensors flow / return	Return is hotter than flow.	Connection, supply line return line switched around,
227 (34) 227 (36) 227 (38) 227 (40) 227 (42) 227 (44) 227 (46) 227 (48) 227 (50) 227 (52) 227 (54) 227 (56)	235	Sensor fault from heat pump	Sensor fault BT3. Sensor fault BT12. Sensor fault BT14. Sensor fault BT15. Sensor fault BT16. Sensor fault BT17. Sensor fault BT28. Sensor fault BT81. Sensor fault BP8. Sensor fault BP9. Sensor fault BP11. Sensor fault BT84.	Open-circuit or short-circuit on sensor input.
228 (2)	236	Unsuccessful defrosting	10 failed consecutive defrostings.	System temperature and/or flow too low. Insufficient available system volume. Significant wind effect.
229 (4)	237	Short run times for compressor	Operation is stopped from the indoor section after less than 5 minutes.	Poor flow, poor heat transfer. Incorrect settings for heating and/or hot water.
230 (78)	238	Hot gas alarm	3 repeated alarms for high discharge within 4 hours.	Disruption in the refrigerant circuit. Lack of refrigerant.
232 (76)	240	Low evaporation temp	5 repeated alarms for low evaporation temperature within 4 hours.	Lack of refrigerant. Blocked expansion valve. Significant wind effect.

<i>Alarms VVM/SMO (F2120)</i>	<i>Alarms S-series</i>	<i>Alarm text on the display</i>	<i>Description existing alarm</i>	<i>May be due to</i>
264 (204)	254	Communication fault with Inverter.	5 communication fault with inverter.	Poor connection between PCB and inverter. Inverter unpowered or broken.
341 (6)	291	Recurring safety defr.	10 repeated defrostings according to the protection conditions.	Poor airflow, e.g. because of leaves, snow or ice. Lack of refrigerant.
344 (72)	294	Recurring low pressure	5 repeated low pressure alarm within 4 hours.	Lack of refrigerant. Blocked expansion valve. Disruption in the refrigerant circuit.
346 (74)	295	Recurring high pressure	5 repeated high pressure alarm within 4 hours.	Clogged particle filter, air or stoppage in the heating medium flow. Poor system pressure.
400 (207) 400 (209) 400 (211) 400 (213)	314	Unspecified faults	Initiation fault, inverter. Inverter not compatible. Configuration file missing. Charge error configuration.	Incompatible inverter.
421 (104)	319	Comm. fault to inverter	3 repeated communication faults within 2 hours or continuously for 1 hour	Communication with AA2-X20 interrupted. Poor connection between PCB and inverter.
425 (108)	322	Deployed pressure switch	2 repeated LP/HP pressure switch alarms within 2.5 hours.	Poor heating medium flow. Lack of refrigerant.
427 (110)	323	Safety stop, inverter	Temporary fault in inverter, 2 times within 60 minutes.	Disruption in supply voltage.
429 (112)	324	Safety stop, inverter	Temporary fault in inverter, 3 times within 2 hours.	Disruption in supply voltage.
431 (114)	325	High mains voltage	Phase voltage to inverter too high, 3 times within 3 hours or persistent for 1 hour.	Disruption in supply voltage.
433 (116)	326	Inverter alarm type I	Phase voltage to inverter too low, 3 times within 3 hours or continuously for 1 hour.	Low supply voltage or phase loss.
435 (118)	327	Inverter alarm type I	Phase L2 has been missing 3 times within 3 hours or continuously for 1 hour.	Phase loss for phase L2.
437 (120)	328	Mains disturbance	Temporary fault in inverter, 3 times within 2 hours or continuously for 1 hour.	Disruption in supply voltage. Incorrect connection in the inverter's terminal block X5.
439 (122)	329	Overheated inverter	The inverter has temporarily reached max working temperature, due to poor cooling 3 times within 2 hours or continuously for 1 hour.	Poor cooling of inverter. Defective inverter.
441 (124)	330	Inverter alarm type II	Current to inverter too high, 3 times within 2 hours or continuously for 1 hour.	Too high current to inverter. Low supply voltage.

<i>Alarms VVM/SMO (F2120)</i>	<i>Alarms S-series</i>	<i>Alarm text on the display</i>	<i>Description existing alarm</i>	<i>May be due to</i>
443 (126)	331	Overheated inverter	The inverter has temporarily reached max working temperature, due to poor cooling 3 times within 2 hours or continuously for 1 hour.	Poor cooling of inverter. Defective inverter.
445 (128)	332	Inverter protection	The inverter detects a temporary fault within 10 seconds after compressor start, 5 times in a row.	Disruption in supply voltage. Defective compressor.
447 (130)	333	Phase failure	Compressor phase is missing, 3 times within 2 hours or continuously for 1 minute.	Disruption in supply voltage. Incorrectly connected compressor cable.
449 (132)	334	Failed compressor starts	Compressor does not start when required, 3 times within 2 hours.	Defective inverter. Defective compressor.
453 (136)	336	High current load, compressor	The output current from the inverter to the compressor has been temporarily too high 3 times within 2 hours or continuously for 1 hour.	Disruption in supply voltage. Poor heating medium flow. Defective compressor.
455 (138)	337	High power load, compressor	The power output from the inverter has been too high 3 times within 2 hours or continuously for 1 hour.	Disruption in supply voltage. Poor heating medium flow. Defective compressor.
501 (184)	353	Failed start, no pressure diff.	The pressure difference between BP9 and BP8 has been too low at compressor start 3 times within 30 minutes.	Fault in pressure sensor BP8, BP9. The compressor does not compress the refrigerant sufficiently. Compressor breakdown.
503	354	Compressor speed too low	Compressor speed below lowest permitted speed.	The inverter's safety function reduces the speed outside of the compressor's working range.



# 10 Accessories

Detailed information about the accessories and complete accessories list available at [nibe.eu](http://nibe.eu).

Not all accessories are available on all markets.

## CONDENSATION WATER PIPE

Condensation water pipe, different lengths.

### *KVR 10-10 F2120*

1 metres

Part no. 067 549

### *KVR 10-30 F2120*

3 metres

Part no. 067 550

### *KVR 10-60 F2120*

6 metres

Part no. 067 551

# 11 Technical data

## Dimensions

F2120-8,

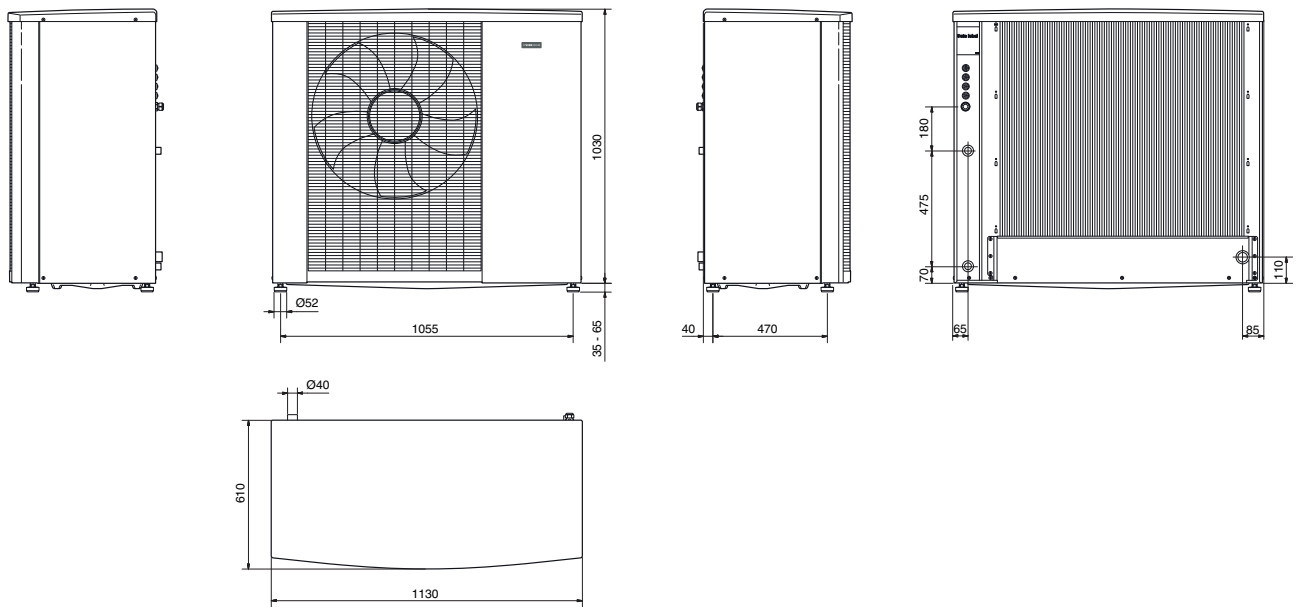

F2120-12, -16, -20

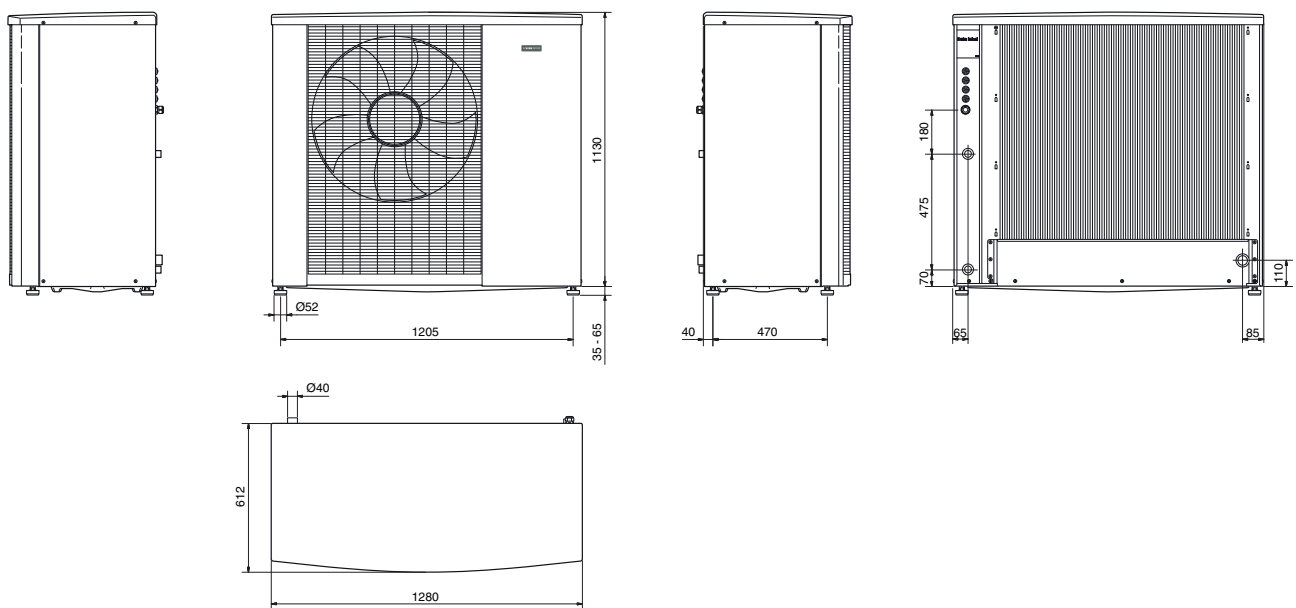

# Sound levels

F2120 is usually placed next to a house wall, which gives a directed sound distribution that should be considered. Accordingly, you should always attempt when position-

ing to choose the side that faces the least sound sensitive neighbouring area.

The sound pressure levels are further affected by walls, bricks, differences in ground level, etc and should therefore only be seen as guide values.

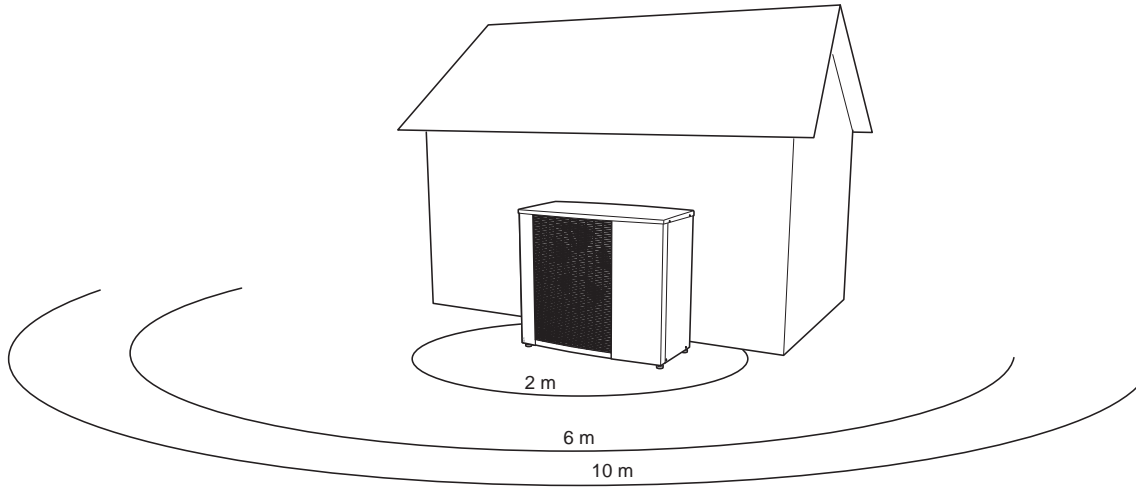

F2120		8	12	16	20
Sound power level ( $L_{WA}$ ), according to EN12102 at 7 / 45 (nominal)	$L_{WA}$ (A)	53	53	55	55
Sound pressure level ( $L_{pA}$ ) at 2 m*	dB(A)	39	39	41	41
Sound pressure level ( $L_{pA}$ ) at 6 m*	dB(A)	29.5	29.5	31.5	31.5
Sound pressure level ( $L_{pA}$ ) at 10 m*	dB(A)	25	25	27	27

\* Free space.

# Technical specifications

F2120 – 1x230V		8	12
<i>Output data according to EN 14511, partial load<sup>1)</sup></i>			
	Outdoor temp./ Supply temp.		
<i>Heating</i> Capacity / Power input / COP (kW/kW/-) at nominal flow	-7 / 35 °C	5.17 / 1.72 / 3.00	7.35 / 2.43 / 3.02
	2 / 35 °C	4.03 / 0.91 / 4.43	5.21 / 1.22 / 4.27
	2 / 45 °C	4.07 / 1.16 / 3.51	5.27 / 1.49 / 3.54
	7 / 35 °C	3.57 / 0.78 / 4.57	3.54 / 0.69 / 5.12
	7 / 45 °C	3.66 / 0.98 / 3.74	3.64 / 0.91 / 4.00
<i>Cooling</i>			
	35 / 7 °C	3.80 / 1.28 / 2.97	4.69 / 1.70 / 2.76
Capacity / Power input / EER (kW/kW/-) at maximum flow	35 / 18 °C	5.10 / 1.37 / 3.73	5.44 / 1.73 / 3.15
<i>Electrical data</i>			
Rated voltage		230V ~ 50Hz	
Max operating current, heat pump	A <sub>rms</sub>	14	16
Max operating current, compressor	A <sub>rms</sub>	13	15
Max output, fan	W	40	45
Fuse	A <sub>rms</sub>	16	16
Enclosure class		IP24	
<i>Refrigerant circuit</i>			
Type of refrigerant		R410A	
GWP refrigerant		2088	
Type of compressor		Scroll	
Volume	kg	2.4	2.6
CO <sub>2</sub> -equivalent (The cooling circuit is hermetically sealed.)	t	5.01	5.43
Cut-out value pressure switch HP (BP1)	MPa	4.5	
Difference pressostat HP	MPa	0.7	
Cut-out value pressure switch LP (BP2)	MPa	0.12	
Difference pressostat LP	MPa	0.7	
<i>Airflow</i>			
Max airflow	m <sup>3</sup> /h	2,400	3,400
Min/Max air temp, heating	°C	-25 / 38	
Min/Max air temp, cooling	°C	15 / 43	
Defrosting system		reverse cycle	
<i>Heating medium circuit</i>			
Max system pressure heating medium		MPa 0.45 (4.5 bar)	
Recommended flow interval, heating operation		l/s 0.08 / 0.32	0.11 / 0.44
Min. design flow, defrosting (100 % pump speed)		l/s 0.27	0.35
Min/Max HM temp continuous operation		°C 26 / 65	
Connection heating medium F2120		G1 1/4" external thread	
Connection heating medium flex pipe		G1 external thread	
Min. recommended pipe dimension (system)		DN (mm) 20 (22)	25 (28)
<i>Dimensions and weight</i>			
Width	mm	1,130	1,280
Depth	mm	610	612
Height with stand	mm	1,070	1,165
Weight (excl. packaging)	kg	153	165
<i>Miscellaneous</i>			
Substances according to Directive (EG) no. 1907/2006, article 33 (Reach)		Lead in brass components	
Part No.		064 134	064 136

F2120 – 3x400V		8	12	16	20	
<i>Output data according to EN 14511, partial load<sup>1)</sup></i>		Outd. temp. / Supply temp.				
Heating Capacity / Power input / COP (kW/kW/-) at nominal flow	-7 / 35 °C	5.17/1.72/3.00	7.35/2.43/3.02	10.13/3.33/3.04	13.50/4.70/2.87	
	2 / 35 °C	4.03/0.91/4.43	5.21/1.22/4.27	7.80/1.79/4.36	9.95/2.36/4.22	
	2 / 45 °C	4.07/1.16/3.51	5.27/1.49/3.54	7.97/2.24/3.56	10.41/2.88/3.61	
	7 / 35 °C	3.57/0.78/4.57	3.54/0.69/5.12	5.17/1.01/5.11	5.17/1.01/5.11	
	7 / 45 °C	3.66/0.98/3.74	3.64/0.91/4.00	5.49/1.33/4.14	5.49/1.33/4.14	
Cooling Capacity / Power input / EER (kW/kW/-) at maximum flow	35 / 7 °C	3.80/1.28/2.97	4.69/1.70/2.76	7.09/2.72/2.61	8.10/3.50/2.31	
	35 / 18 °C	5.10/1.37/3.73	5.44/1.73/3.15	8.19/2.83/2.90	9.26/3.64/2.54	
<i>Electrical data</i>						
Rated voltage		400V 3N ~ 50Hz				
Max operating current, heat pump	A <sub>rms</sub>	6	7	9.5	11	
Max operating current, compressor	A <sub>rms</sub>	5	6	8.5	10	
Max output, fan	W	40	45	68	80	
Fuse	A <sub>rms</sub>	10	10	10	13	
Enclosure class		IP24				
<i>Refrigerant circuit</i>						
Type of refrigerant		R410A				
GWP refrigerant		2088				
Type of compressor		Scroll				
Volume	kg	2.4	2.6	3	3	
CO <sub>2</sub> -equivalent (The cooling circuit is hermetically sealed.)		t	5.01	5.43	6.26	6.26
Cut-out value pressure switch HP (BP1)		MPa	4.5			
Difference pressostat HP		MPa	0.7			
Cut-out value pressure switch LP (BP2)		MPa	0.12			
Difference pressostat LP		MPa	0.7			
<i>Airflow</i>						
Max airflow	m <sup>3</sup> /h	2,400	3,400	4,150	4,500	
Min/Max air temp, heating		°C	-25 / 38			
Min/Max air temp, cooling		°C	15 / 43			
Defrosting system		reverse cycle				
<i>Heating medium</i>						
Max system pressure heating medium		MPa	0.45 (4.5 bar)			
Recommended flow interval, heating operation		l/s	0.08/0.32	0.11/0.44	0.15/0.60	0.19/0.75
Min. design flow, defrosting (100 % pump speed)		l/s	0.27	0.35	0.38	0.48
Min/Max HM temp continuous operation		°C	26 / 65			
Connection heating medium F2120		G1 1/4" external thread				
Connection heating medium flex pipe		G1 external thread		G1 1/4" external thread		
Min. recommended pipe dimension (system)		DN (mm)	20 (22)	25 (28)	25 (28)	32 (35)
<i>Dimensions and weight</i>						
Width	mm	1,130	1,280			
Depth	mm	610	612			
Height with stand	mm	1,070	1,165			
Weight (excl. packaging)	kg	170	180	185		
<i>Miscellaneous</i>						
Substances according to Directive (EG) no. 1907/2006, article 33 (Reach)		Lead in brass components				
Part No.		064 135	064 137	064139	064 141	

SCOP & $P_{designh}$ F2120 according to EN 14825								
F2120	8		12		16		20	
	$P_{designh}$	SCOP	$P_{designh}$	SCOP	$P_{designh}$	SCOP	$P_{designh}$	SCOP
SCOP 35 Average climate (Europe)	5.9	4.80	8	4.83	11	5.05	11	5.05
SCOP 55 Average climate (Europe)	6.3	3.75	8.3	3.78	12.3	3.9	12.3	3.9
SCOP 35 Cold climate	6.8	4.03	9.3	4.05	13	4.25	13	4.25
SCOP 55 Cold climate	7.4	3.33	9.8	3.33	14	3.53	14	3.53
SCOP 35 Warm climate	5.9	5.43	9.2	5.48	13	5.5	13	5.5
SCOP 55 Warm climate	6.3	4.35	9.2	4.48	13	4.5	13	4.5

<sup>1</sup>Power statements including defrosting according to EN 14511 at heating medium supply corresponding to DT=5 K at 7 / 45.

<sup>2</sup>Nominal flow corresponds to DT=10 K at 7 / 45.

## ENERGY RATING, AVERAGE CLIMATE

Model		F2120-8	F2120-12	F2120-16	F2120-20
Control module model		SMO	SMO	SMO	SMO
Temperature application	°C	35 / 55	35 / 55	35 / 55	35 / 55
The product's room heating efficiency class <sup>1</sup>		A+++ / A++	A+++ / A++	A+++ / A+++	A+++ / A+++
Space heating efficiency class of the system <sup>2</sup>		A+++ / A+++	A+++ / A+++	A+++ / A+++	A+++ / A+++

<sup>1</sup>Scale for the product's room heating efficiency class A++ to G.

<sup>2</sup>Scale for the system's room heating efficiency class A+++ to G.

The reported efficiency of the package also takes the controller into account. If an external supplementary boiler or solar heating is added to the package, the overall efficiency of the package should be recalculated.

# Working area

*F2120-8 working range*

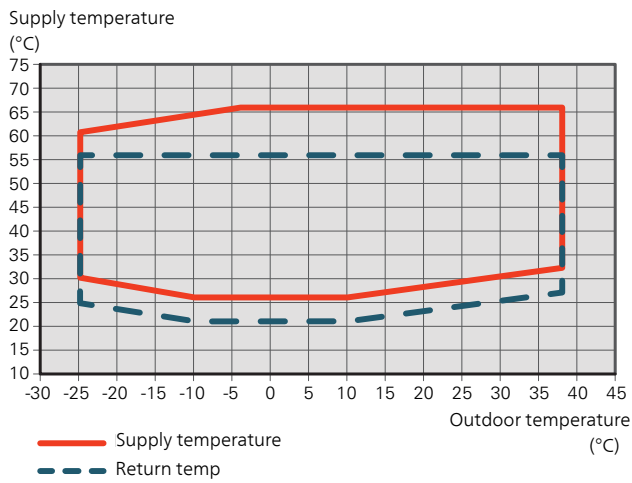

*F2120-12 working range*

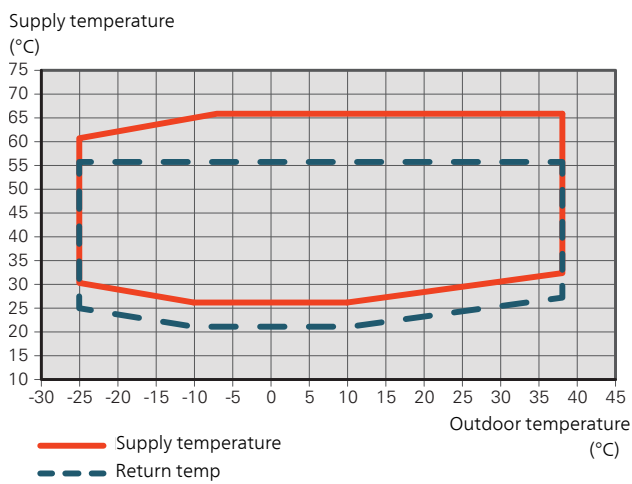

*F2120-16 / F2120-20 working range*

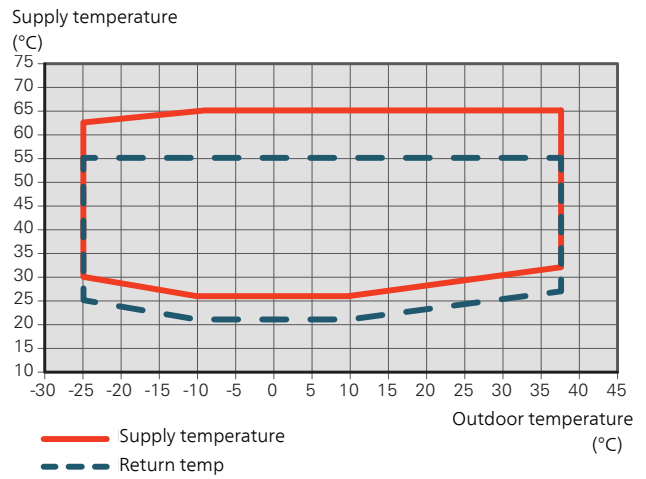

*F2120 working range cooling*

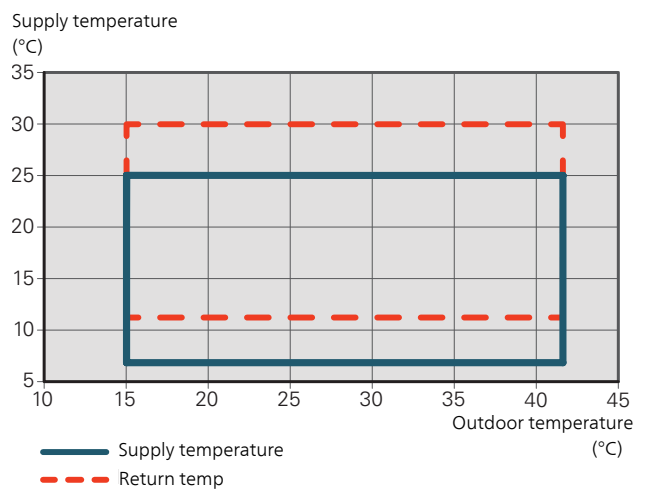

During shorter time it is allowed to have lower working temperatures on the water side, e.g. during start up.

# Heating

## OUTPUT AND COP AT DIFFERENT SUPPLY TEMPERATURES

Maximum capacity during continuous operation. Defrosting is not included.

### F2120-8

F2120-8 max and min heating capacity

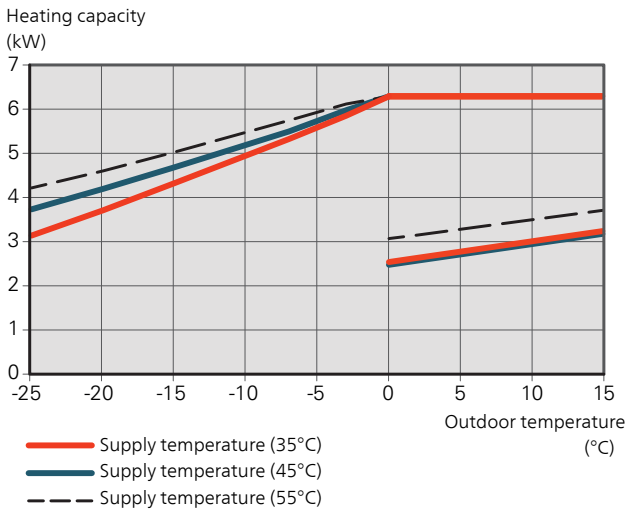

### F2120-8 COP

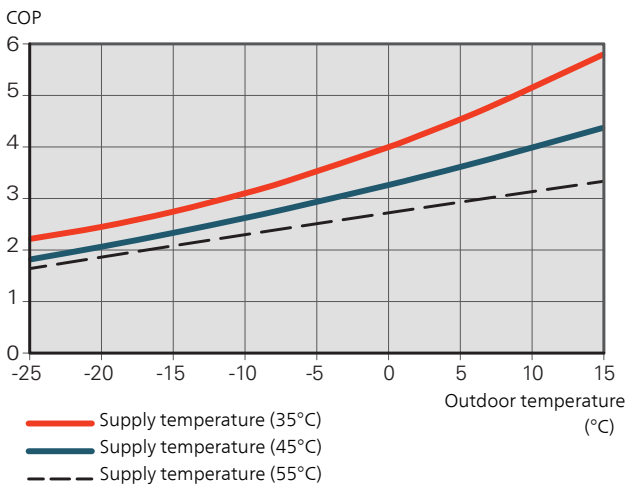

### F2120-12

F2120-12 max and min heating capacity

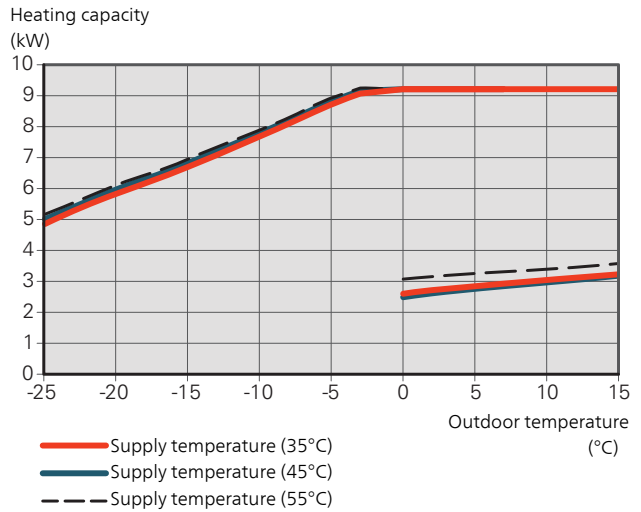

### F2120-12 COP

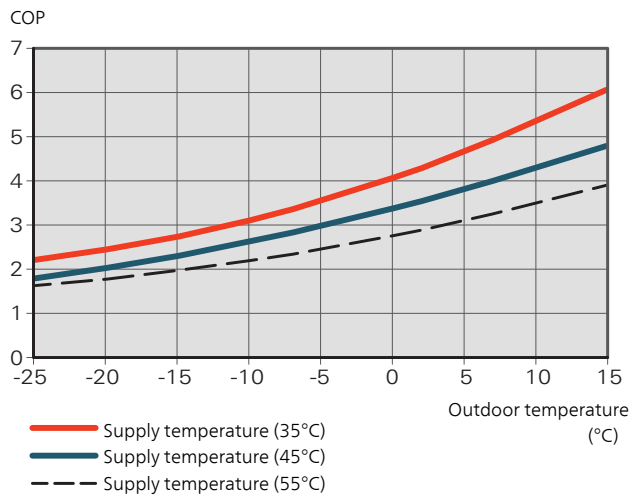



## F2120-16

F2120-16 max and min heating capacity

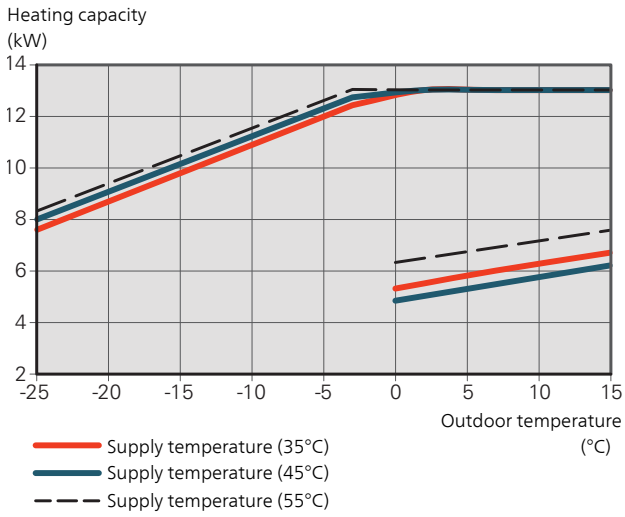

## F2120-20

F2120-20 max and min heating capacity

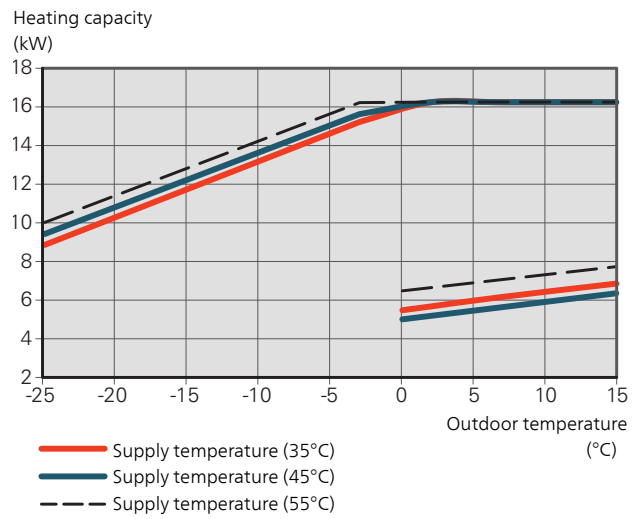

## F2120-16 COP

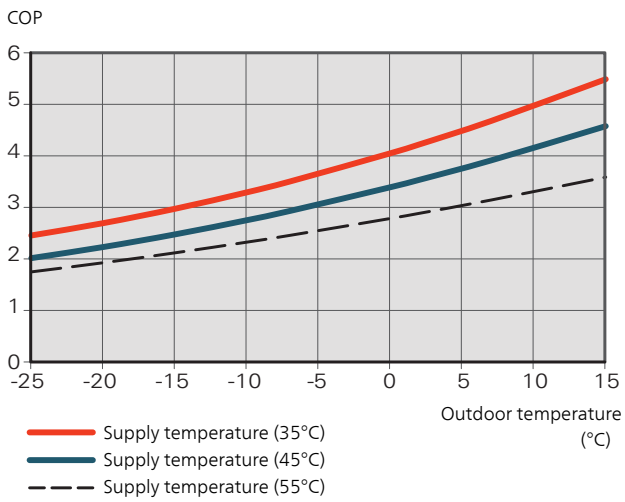

## F2120-20 COP

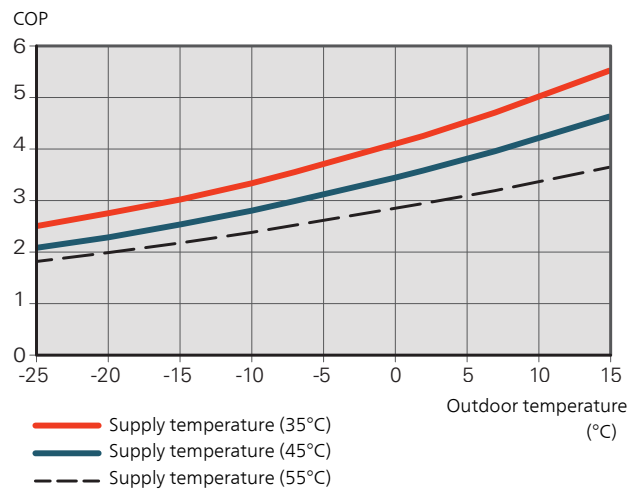

# Cooling

## OUTPUT AT DIFFERENT SUPPLY TEMPERATURES (COOLING)

*F2120-8 max and min cooling capacity*

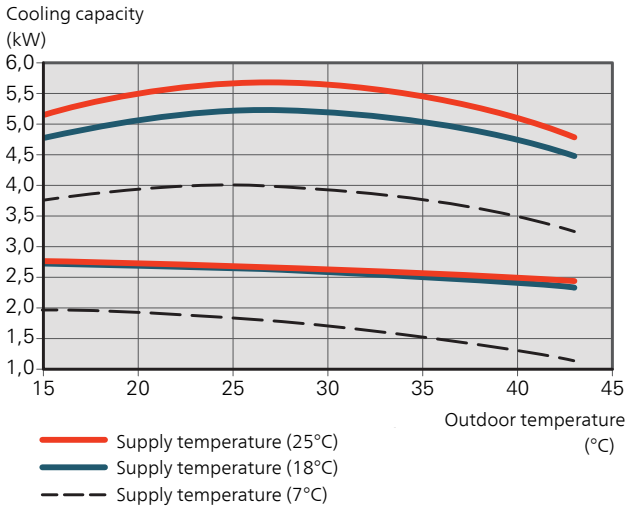

*F2120-12 max and min cooling capacity*

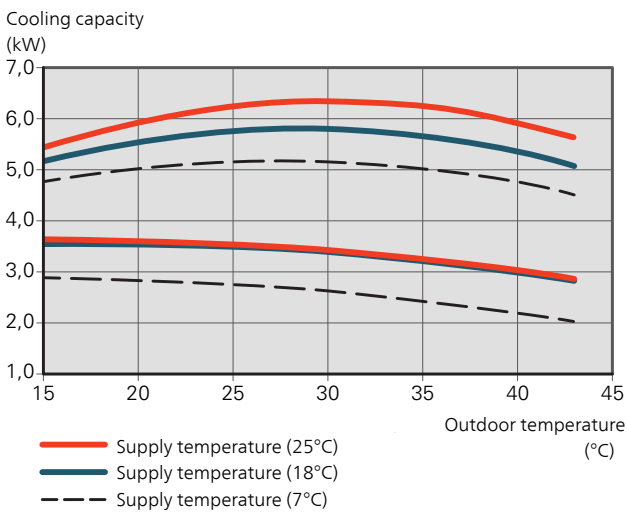

*F2120-16 max and min cooling capacity*

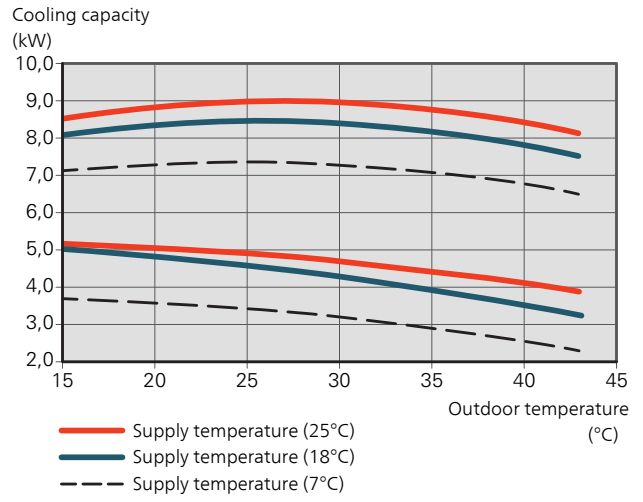

*F2120-20 max and min cooling capacity*

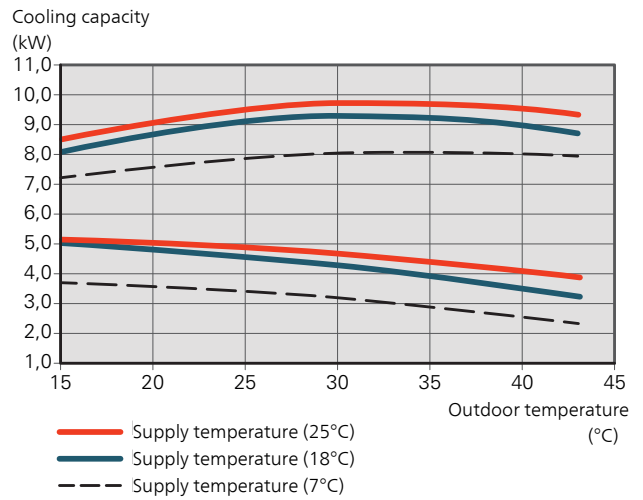

# Energy labelling

## INFORMATION SHEET

Supplier		NIBE			
Model		F2120-8	F2120-12	F2120-16	F2120-20
Temperature application	°C	35 / 55	35 / 55	35 / 55	35 / 55
Seasonal space heating energy efficiency class, average climate		<b>A+++ / A++</b>	<b>A+++ / A++</b>	<b>A+++ / A+++</b>	<b>A+++ / A+++</b>
Rated heat output ( $P_{\text{designh}}$ ), average climate	kW	5.9 / 6.3	8.0 / 8.3	11.0 / 12.3	11.0 / 12.3
Annual energy consumption space heating, average climate	kWh	2,544 / 3,472	3,409 / 4,529	4,502 / 6,524	4,502 / 6,524
Seasonal space heating energy efficiency, average climate	%	189 / 147	190 / 148	199 / 153	199 / 153
Sound power level $L_{\text{WA}}$ indoors	dB	35	35	35	35
Rated heat output ( $P_{\text{designh}}$ ), cold climate	kW	6.8 / 7.4	9.3 / 9.8	13.0 / 14.0	13.0 / 14.0
Rated heat output ( $P_{\text{designh}}$ ), warm climate	kW	5.9 / 6.3	9.2 / 9.2	13.0 / 13.0	13.0 / 13.0
Annual energy consumption space heating, cold climate	kWh	4,182 / 5,524	5,666 / 7,239	7,543 / 9,765	7,543 / 9,765
Annual energy consumption space heating, warm climate	kWh	1,452 / 1,939	2,241 / 2,741	3,153 / 3,867	3,153 / 3,867
Seasonal space heating energy efficiency, cold climate	%	158 / 130	159 / 130	167 / 138	167 / 138
Seasonal space heating energy efficiency, warm climate	%	214 / 171	216 / 176	217 / 177	217 / 177
Sound power level $L_{\text{WA}}$ outdoors	dB	53	53	55	55

## DATA FOR ENERGY EFFICIENCY OF THE PACKAGE

Model		F2120-8	F2120-12	F2120-16	F2120-20
Control module model		SMO	SMO	SMO	SMO
Temperature application	°C	35 / 55	35 / 55	35 / 55	35 / 55
Controller, class		VI			
Controller, contribution to efficiency	%	4.0			
Seasonal space heating energy efficiency of the package, average climate	%	193 / 151	194 / 152	203 / 157	203 / 157
Seasonal space heating energy efficiency class of the package, average climate		<b>A+++ / A+++</b>	<b>A+++ / A+++</b>	<b>A+++ / A+++</b>	<b>A+++ / A+++</b>
Seasonal space heating energy efficiency of the package, cold climate	%	162 / 134	163 / 134	171 / 142	171 / 142
Seasonal space heating energy efficiency of the package, warm climate	%	218 / 175	220 / 180	221 / 181	221 / 181

The reported efficiency of the package also takes the controller into account. If an external supplementary boiler or solar heating is added to the package, the overall efficiency of the package should be recalculated.

# TECHNICAL DOCUMENTATION

Model		F2120-8					
Type of heat pump	<input checked="" type="checkbox"/> Air-water <input type="checkbox"/> Exhaust-water <input type="checkbox"/> Brine-water <input type="checkbox"/> Water-water						
Low-temperature heat pump	<input type="checkbox"/> Yes <input checked="" type="checkbox"/> No						
Integrated immersion heater for additional heat	<input type="checkbox"/> Yes <input checked="" type="checkbox"/> No						
Heat pump combination heater	<input type="checkbox"/> Yes <input checked="" type="checkbox"/> No						
Climate	<input checked="" type="checkbox"/> Average <input type="checkbox"/> Cold <input type="checkbox"/> Warm						
Temperature application	<input checked="" type="checkbox"/> Average (55 °C) <input type="checkbox"/> Low (35 °C)						
Applied standards	EN14825 / EN14511 / EN16147 / EN12102						
Rated heat output	Prated	6,3	kW	Seasonal space heating energy efficiency	$\eta_s$	147	%
Declared capacity for space heating at part load and at outdoor temperature $T_j$				Declared coefficient of performance for space heating at part load and at outdoor temperature $T_j$			
$T_j = -7\text{ °C}$	Pdh	5.5	kW	$T_j = -7\text{ °C}$	COPd	2.48	-
$T_j = +2\text{ °C}$	Pdh	4.1	kW	$T_j = +2\text{ °C}$	COPd	3.80	-
$T_j = +7\text{ °C}$	Pdh	2.9	kW	$T_j = +7\text{ °C}$	COPd	4.45	-
$T_j = +12\text{ °C}$	Pdh	3.3	kW	$T_j = +12\text{ °C}$	COPd	5.26	-
$T_j = \text{biv}$	Pdh	5.5	kW	$T_j = \text{biv}$	COPd	2.48	-
$T_j = \text{TOL}$	Pdh	5.7	kW	$T_j = \text{TOL}$	COPd	2.34	-
$T_j = -15\text{ °C}$ (if $\text{TOL} < -20\text{ °C}$ )	Pdh		kW	$T_j = -15\text{ °C}$ (if $\text{TOL} < -20\text{ °C}$ )	COPd		-
Bivalent temperature	$T_{\text{biv}}$	-7	°C	Min. outdoor air temperature	TOL	-10	°C
Cycling interval capacity	P <sub>psych</sub>		kW	Cycling interval efficiency	COP <sub>psych</sub>		-
Degradation coefficient	Cdh	0.99	-	Max supply temperature	WTOL	65	°C
Power consumption in modes other than active mode				Additional heat			
Off mode	P <sub>OFF</sub>	0.025	kW	Rated heat output	P <sub>sup</sub>	0.0	kW
Thermostat-off mode	P <sub>TO</sub>	0.01	kW				
Standby mode	P <sub>SB</sub>	0.025	kW	Type of energy input	Electric		
Crankcase heater mode	P <sub>CK</sub>	0.037	kW				
<i>Other items</i>							
Capacity control	Variable			Rated airflow (air-water)		2,400	m <sup>3</sup> /h
Sound power level, indoors/outdoors	L <sub>WA</sub>	35 / 53	dB	Nominal heating medium flow			
Annual energy consumption	Q <sub>HE</sub>	3,472	kWh	Brine flow brine-water or water-water heat pumps			
Contact information	NIBE Energy Systems – Box 14 – Hannabadvägen 5 – 285 21 Markaryd – Sweden						

Model		F2120-12					
Type of heat pump	<input checked="" type="checkbox"/> Air-water <input type="checkbox"/> Exhaust-water <input type="checkbox"/> Brine-water <input type="checkbox"/> Water-water						
Low-temperature heat pump	<input type="checkbox"/> Yes <input checked="" type="checkbox"/> No						
Integrated immersion heater for additional heat	<input type="checkbox"/> Yes <input checked="" type="checkbox"/> No						
Heat pump combination heater	<input type="checkbox"/> Yes <input checked="" type="checkbox"/> No						
Climate	<input checked="" type="checkbox"/> Average <input type="checkbox"/> Cold <input type="checkbox"/> Warm						
Temperature application	<input checked="" type="checkbox"/> Average (55 °C) <input type="checkbox"/> Low (35 °C)						
Applied standards	EN14825 / EN14511 / EN16147 / EN12102						
Rated heat output	Prated	8,3	kW	Seasonal space heating energy efficiency	$\eta_s$	148	%
Declared capacity for space heating at part load and at outdoor temperature $T_j$				Declared coefficient of performance for space heating at part load and at outdoor temperature $T_j$			
$T_j = -7\text{ °C}$	Pdh	7.3	kW	$T_j = -7\text{ °C}$	COPd	2.39	-
$T_j = +2\text{ °C}$	Pdh	4.7	kW	$T_j = +2\text{ °C}$	COPd	3.85	-
$T_j = +7\text{ °C}$	Pdh	2.9	kW	$T_j = +7\text{ °C}$	COPd	4.48	-
$T_j = +12\text{ °C}$	Pdh	3.3	kW	$T_j = +12\text{ °C}$	COPd	5.30	-
$T_j = \text{biv}$	Pdh	7.3	kW	$T_j = \text{biv}$	COPd	2.39	-
$T_j = \text{TOL}$	Pdh	7.8	kW	$T_j = \text{TOL}$	COPd	2.28	-
$T_j = -15\text{ °C}$ (if TOL < -20 °C)	Pdh		kW	$T_j = -15\text{ °C}$ (if TOL < -20 °C)	COPd		-
Bivalent temperature	$T_{\text{biv}}$	-7	°C	Min. outdoor air temperature	TOL	-10	°C
Cycling interval capacity	Pcyc		kW	Cycling interval efficiency	COPcyc		-
Degradation coefficient	Cdh	0.99	-	Max supply temperature	WTOL	65	°C
Power consumption in modes other than active mode				Additional heat			
Off mode	$P_{\text{OFF}}$	0.025	kW	Rated heat output	Psup	0.5	kW
Thermostat-off mode	$P_{\text{TO}}$	0.007	kW				
Standby mode	$P_{\text{SB}}$	0.025	kW	Type of energy input	Electric		
Crankcase heater mode	$P_{\text{CK}}$	0.037	kW				
Other items							
Capacity control	Variable			Rated airflow (air-water)		3,400	m <sup>3</sup> /h
Sound power level, indoors/outdoors	$L_{\text{WA}}$	35 / 53	dB	Nominal heating medium flow			m <sup>3</sup> /h
Annual energy consumption	$Q_{\text{HE}}$	4,529	kWh	Brine flow brine-water or water-water heat pumps			m <sup>3</sup> /h
Contact information	NIBE Energy Systems – Box 14 – Hannabadsvägen 5 – 285 21 Markaryd – Sweden						

Model		F2120-16					
Type of heat pump	<input checked="" type="checkbox"/> Air-water <input type="checkbox"/> Exhaust-water <input type="checkbox"/> Brine-water <input type="checkbox"/> Water-water						
Low-temperature heat pump	<input type="checkbox"/> Yes <input checked="" type="checkbox"/> No						
Integrated immersion heater for additional heat	<input type="checkbox"/> Yes <input checked="" type="checkbox"/> No						
Heat pump combination heater	<input type="checkbox"/> Yes <input checked="" type="checkbox"/> No						
Climate	<input checked="" type="checkbox"/> Average <input type="checkbox"/> Cold <input type="checkbox"/> Warm						
Temperature application	<input checked="" type="checkbox"/> Average (55 °C) <input type="checkbox"/> Low (35 °C)						
Applied standards	EN14825 / EN14511 / EN16147 / EN12102						
Rated heat output	Prated	12,3	kW	Seasonal space heating energy efficiency	$\eta_s$	153	%
Declared capacity for space heating at part load and at outdoor temperature $T_j$				Declared coefficient of performance for space heating at part load and at outdoor temperature $T_j$			
$T_j = -7\text{ °C}$	Pdh	10.9	kW	$T_j = -7\text{ °C}$	COPd	2.48	-
$T_j = +2\text{ °C}$	Pdh	6.7	kW	$T_j = +2\text{ °C}$	COPd	3.96	-
$T_j = +7\text{ °C}$	Pdh	5.9	kW	$T_j = +7\text{ °C}$	COPd	4.67	-
$T_j = +12\text{ °C}$	Pdh	6.5	kW	$T_j = +12\text{ °C}$	COPd	5.67	-
$T_j = \text{biv}$	Pdh	10.9	kW	$T_j = \text{biv}$	COPd	2.48	-
$T_j = \text{TOL}$	Pdh	11.6	kW	$T_j = \text{TOL}$	COPd	2.40	-
$T_j = -15\text{ °C}$ (if TOL < -20 °C)	Pdh		kW	$T_j = -15\text{ °C}$ (if TOL < -20 °C)	COPd		-
Bivalent temperature	$T_{\text{biv}}$	-7	°C	Min. outdoor air temperature	TOL	-10	°C
Cycling interval capacity	Pcyc		kW	Cycling interval efficiency	COPcyc		-
Degradation coefficient	Cdh	0.99	-	Max supply temperature	WTOL	65	°C
Power consumption in modes other than active mode				Additional heat			
Off mode	$P_{\text{OFF}}$	0.025	kW	Rated heat output	Psup	0.7	kW
Thermostat-off mode	$P_{\text{TO}}$	0.007	kW				
Standby mode	$P_{\text{SB}}$	0.025	kW	Type of energy input	Electric		
Crankcase heater mode	$P_{\text{CK}}$	0.037	kW				
Other items							
Capacity control	Variable			Rated airflow (air-water)		4,150	m <sup>3</sup> /h
Sound power level, indoors/outdoors	$L_{\text{WA}}$	35 / 55	dB	Nominal heating medium flow			m <sup>3</sup> /h
Annual energy consumption	$Q_{\text{HE}}$	6,524	kWh	Brine flow brine-water or water-water heat pumps			m <sup>3</sup> /h
Contact information	NIBE Energy Systems – Box 14 – Hannabadsvägen 5 – 285 21 Markaryd – Sweden						

Model				F2120-20			
Type of heat pump	<input checked="" type="checkbox"/> Air-water <input type="checkbox"/> Exhaust-water <input type="checkbox"/> Brine-water <input type="checkbox"/> Water-water						
Low-temperature heat pump	<input type="checkbox"/> Yes <input checked="" type="checkbox"/> No						
Integrated immersion heater for additional heat	<input type="checkbox"/> Yes <input checked="" type="checkbox"/> No						
Heat pump combination heater	<input type="checkbox"/> Yes <input checked="" type="checkbox"/> No						
Climate	<input checked="" type="checkbox"/> Average <input type="checkbox"/> Cold <input type="checkbox"/> Warm						
Temperature application	<input checked="" type="checkbox"/> Average (55 °C) <input type="checkbox"/> Low (35 °C)						
Applied standards	EN14825 / EN14511 / EN16147 / EN12102						
Rated heat output	Prated	12,3	kW	Seasonal space heating energy efficiency	$\eta_s$	153	%
Declared capacity for space heating at part load and at outdoor temperature $T_j$				Declared coefficient of performance for space heating at part load and at outdoor temperature $T_j$			
$T_j = -7\text{ °C}$	Pdh	10.9	kW	$T_j = -7\text{ °C}$	COPd	2.48	-
$T_j = +2\text{ °C}$	Pdh	6.7	kW	$T_j = +2\text{ °C}$	COPd	3.96	-
$T_j = +7\text{ °C}$	Pdh	5.9	kW	$T_j = +7\text{ °C}$	COPd	4.67	-
$T_j = +12\text{ °C}$	Pdh	6.5	kW	$T_j = +12\text{ °C}$	COPd	5.67	-
$T_j = \text{biv}$	Pdh	10.9	kW	$T_j = \text{biv}$	COPd	2.48	-
$T_j = \text{TOL}$	Pdh	11.6	kW	$T_j = \text{TOL}$	COPd	2.40	-
$T_j = -15\text{ °C}$ (if TOL < -20 °C)	Pdh		kW	$T_j = -15\text{ °C}$ (if TOL < -20 °C)	COPd		-
Bivalent temperature	$T_{\text{biv}}$	-7	°C	Min. outdoor air temperature	TOL	-10	°C
Cycling interval capacity	Pcyc		kW	Cycling interval efficiency	COPcyc		-
Degradation coefficient	Cdh	0.99	-	Max supply temperature	WTOL	65	°C
Power consumption in modes other than active mode				Additional heat			
Off mode	$P_{\text{OFF}}$	0.025	kW	Rated heat output	Psup	0.7	kW
Thermostat-off mode	$P_{\text{TO}}$	0.007	kW				
Standby mode	$P_{\text{SB}}$	0.025	kW	Type of energy input	Electric		
Crankcase heater mode	$P_{\text{CK}}$	0.037	kW				
Other items							
Capacity control	Variable			Rated airflow (air-water)		4,150	m <sup>3</sup> /h
Sound power level, indoors/outdoors	$L_{\text{WA}}$	35 / 55	dB	Nominal heating medium flow			m <sup>3</sup> /h
Annual energy consumption	$Q_{\text{HE}}$	6,524	kWh	Brine flow brine-water or water-water heat pumps			m <sup>3</sup> /h
Contact information	NIBE Energy Systems – Box 14 – Hannabadsvägen 5 – 285 21 Markaryd – Sweden						





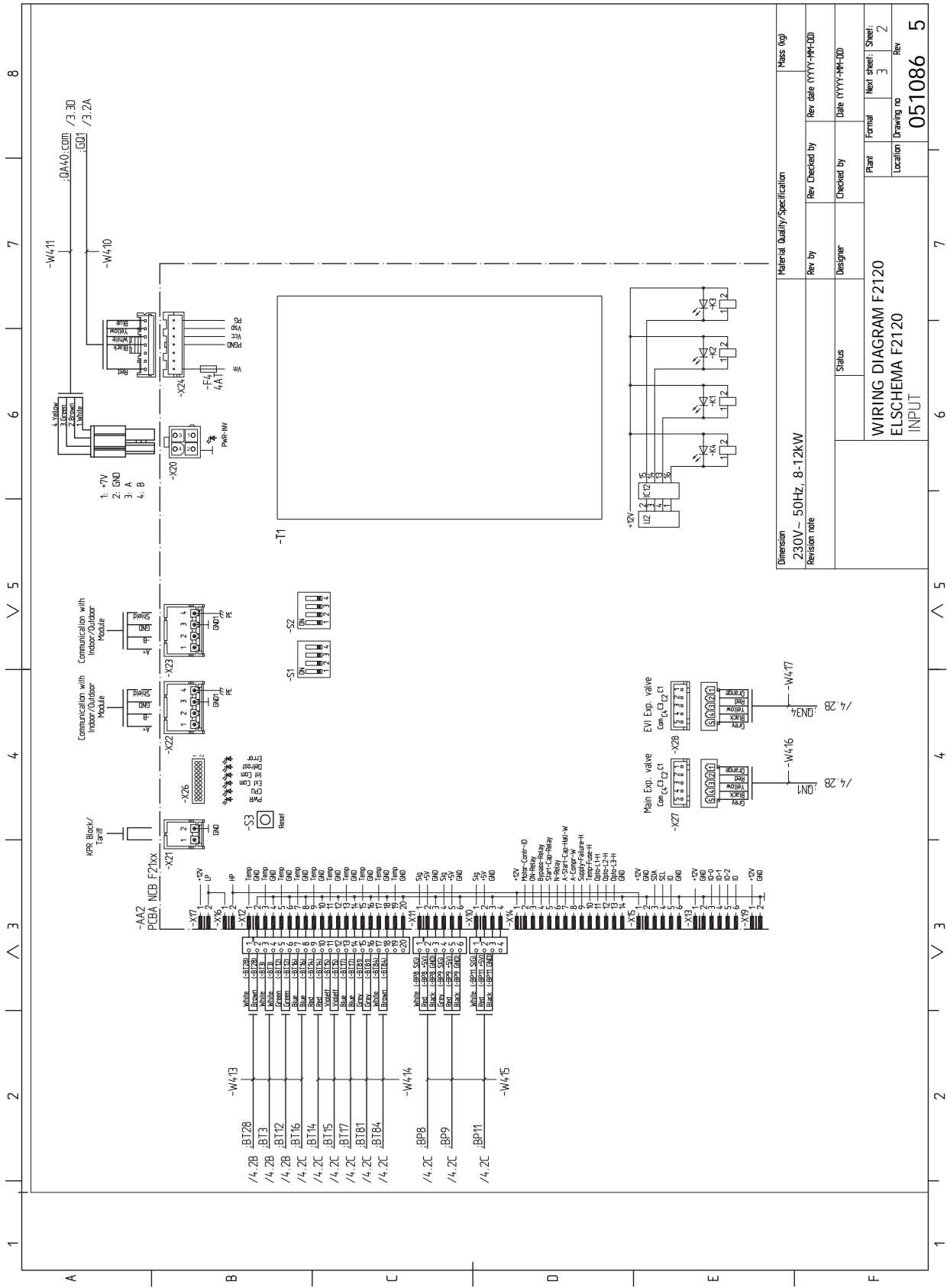

Material Quality/Specification		Hass (kg)	
Dimension	230V - 50Hz, 8-12kW	Rev by	Rev date (YYYY-MM-DD)
Revision note		Designer	Checked by
Status		Plant	Next sheet
WIRING DIAGRAM F2120		Location	Drawing no
ELSCHEMA F2120		Rev	051086
INPUT		Rev	5

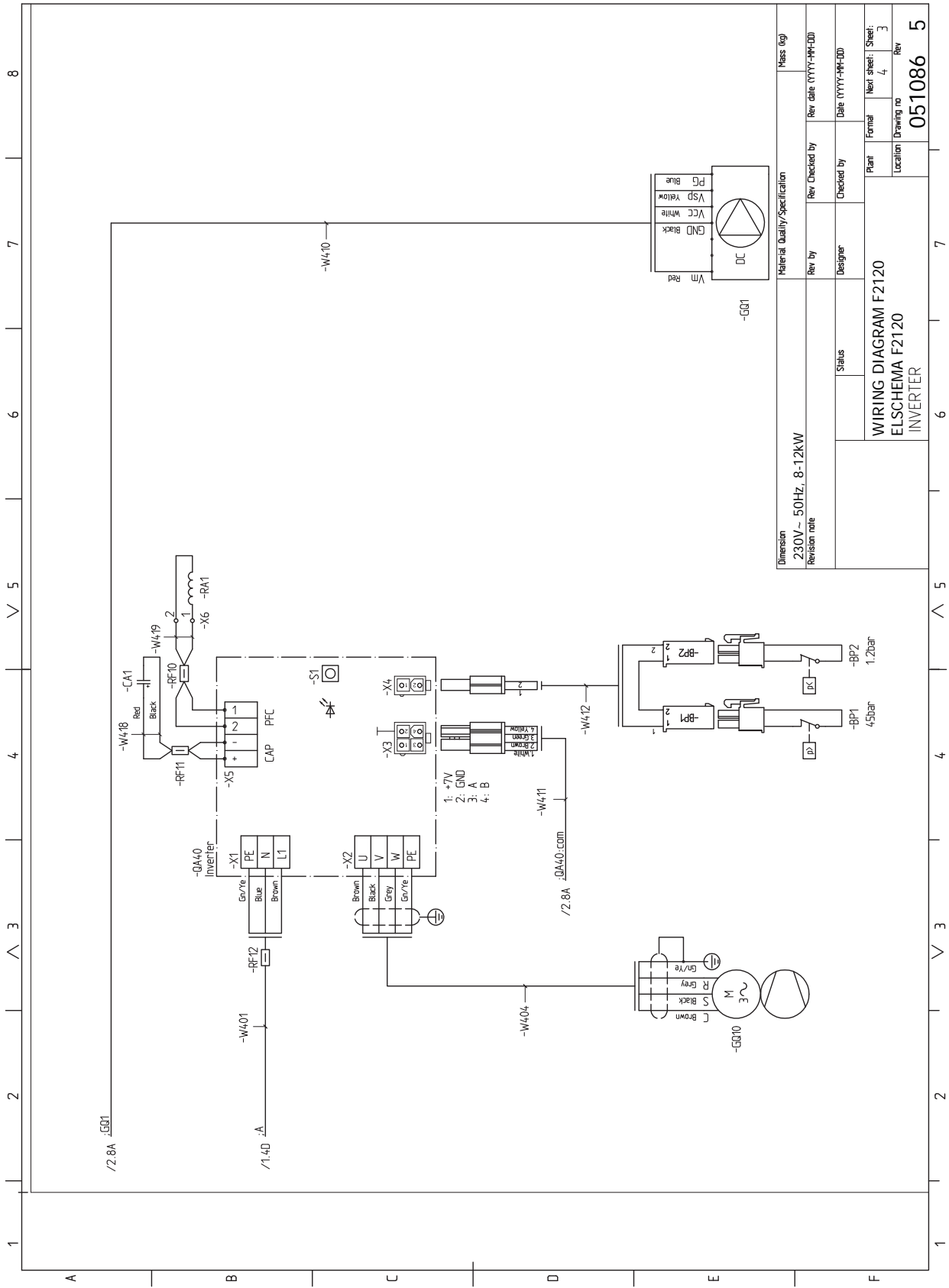

Dimension		Material Quality/Specification		Mass (kg)	
230V - 50Hz, 8-12kW					
Revision note		Rev by	Rev Checked by	Rev date	(YYYY-MM-DD)
		Designer	Checked by	Date	(YYYY-MM-DD)
		Status	Plant	Format	Next sheet: Sheet: 3
		WIRING DIAGRAM F2120		Location	Drawing no
		ELSCHEMA F2120			051086
		INVERTER			5

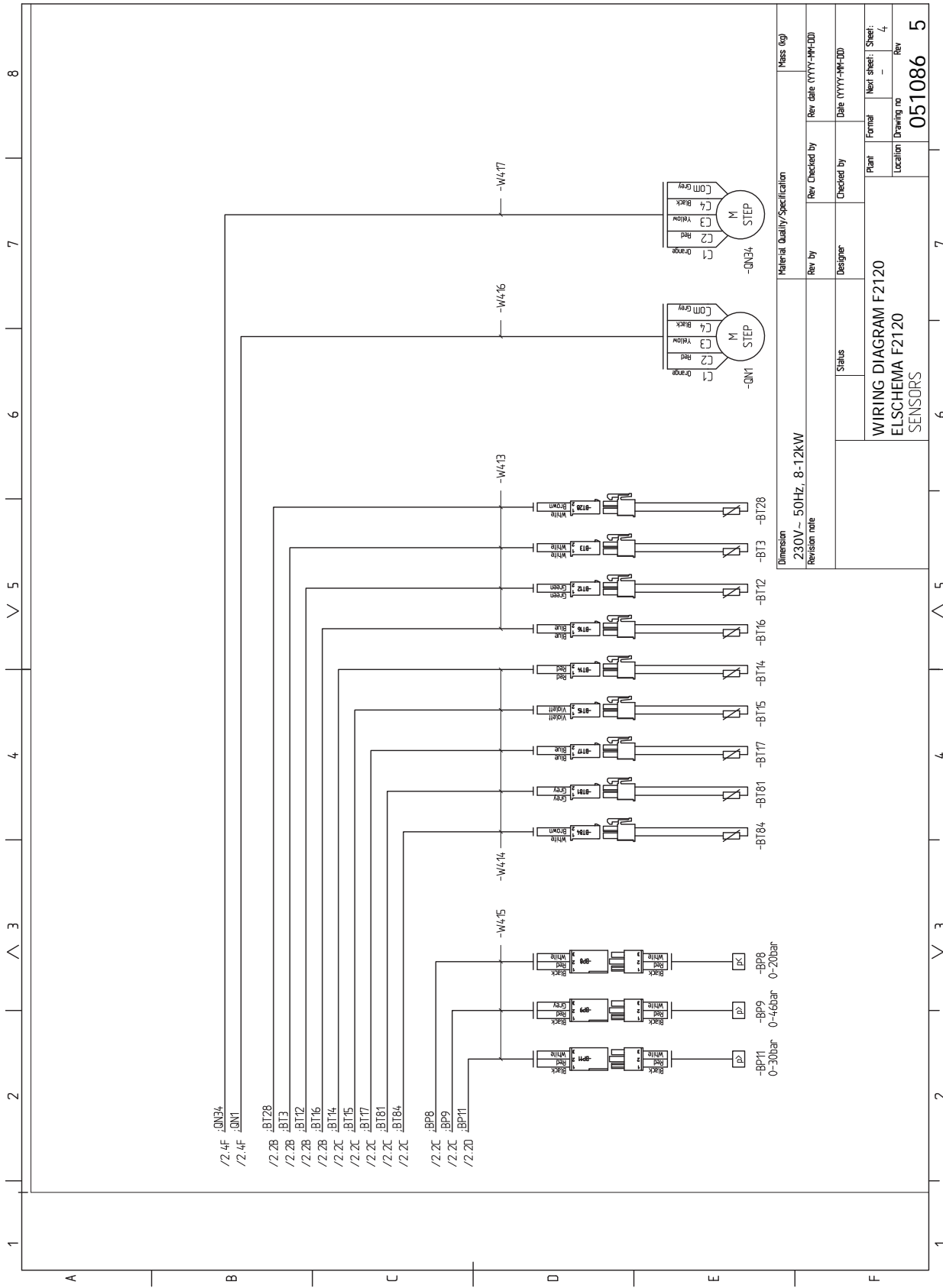

Material Quality Specification		Mass (kg)	
Rev by	Rev Checked by	Rev Date (YYYY-MM-DD)	
Designer	Checked by	Date (YYYY-MM-DD)	
Status		Plant	Next sheet: Sheet: 4
WIRING DIAGRAM F2120		Location	Drawing no
ELSCHEMA F2120			051086
SENSORS			5



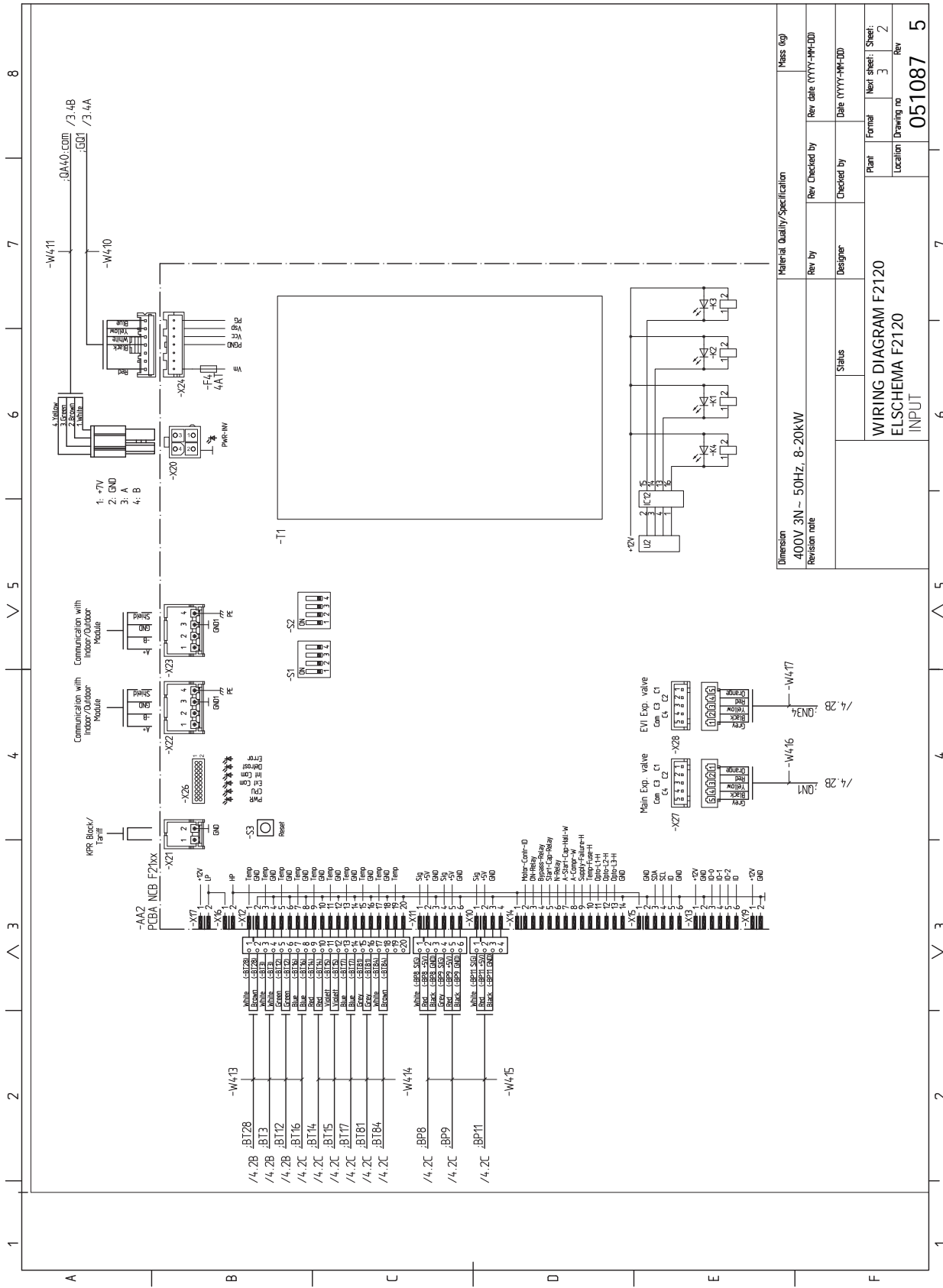

Material Quality/Specification		Mass (kg)	
Dimension	400V 3N ~ 50Hz, 8-20KW	Rev by	Rev Checked by
Revision note		Designer	Date (YYYY-MM-DD)
Status		Plant	Next sheet: Sheet: 2
WIRING DIAGRAM F2120		Location	Drawing no
ELSCHEMA F2120			051087
INPUT		Rev	5



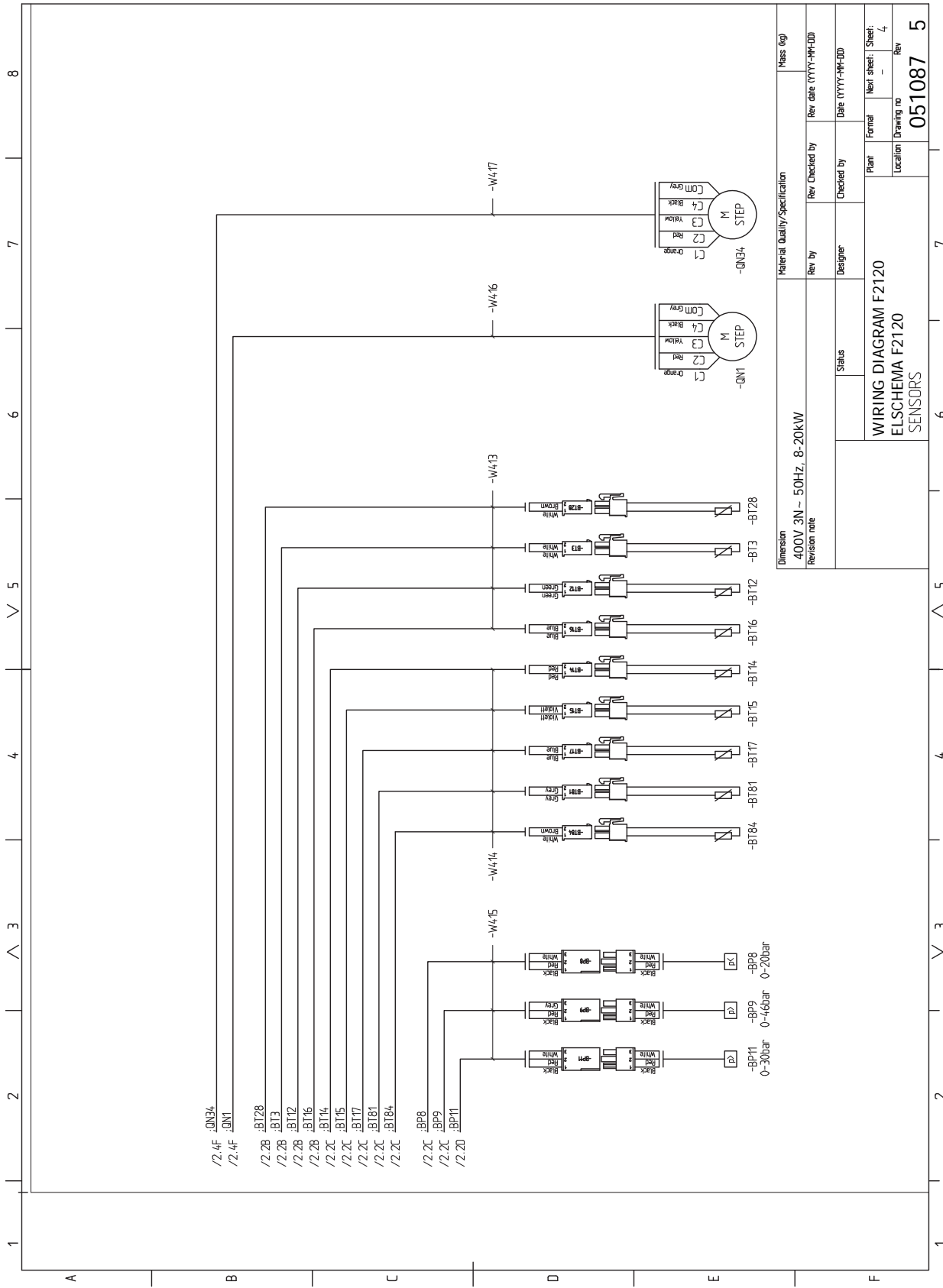

Material Quality Specification		Mass (kg)	
Dimension	400V 3N ~ 50Hz, 8-20KW	Rev by	Rev date (YYYY-MM-DD)
Revision note		Designer	Checked by
WIRING DIAGRAM F2120 ELSCHEMA F2120 SENSORS		Plant	Next sheet: Sheet: 4
		Location	Drawing no 051087 Rev 5

# Item register

- A**
  - Accessories, 49
  - Addressing via multi-heat pump operation, 26
  - Adjustment, charge flow, 36
  - Alarm list, 46
  - Assembly, 10
- B**
  - Balance temperature, 34
  - Basic actions, 42
- C**
  - Charge pump, 22
  - Commissioning and adjusting, 34
    - Adjustment, charge flow, 36
    - Balance temperature, 34
    - Filling and venting the heating medium system, 34
    - Preparations, 34
    - Readjusting, heating medium side, 35
    - Start-up and inspection, 35
  - Communication, 30
  - Compatible indoor modules (VVM) and control modules (SMO), 8
  - Compressor heater, 11
  - Connecting accessories, 33
  - Connecting external control voltage, 28
  - Connections, 27
    - Connecting external control voltage, 28
  - Control, 37
    - Control - Introduction, 37
  - Control conditions, 39
  - Control conditions defrosting, 39
  - Control - Heat pump EB101, 40
  - Control – Heat pump EB101
    - Heat pump settings – Menu 7.3.2, 40
  - Control - Introduction, 37
    - Control conditions, 39
    - Control conditions defrosting, 39
    - Control - Heat pump EB101, 40
    - General, 37
    - LED status, 37
    - Master control, 38
  - Control module, 9
- D**
  - Delivery and handling, 10
    - Assembly, 10
    - Compressor heater, 11
    - Installation area, 14
    - Removing the side cover, 16
    - Supplied components, 15
    - Transport and storage, 10
  - Dimensions and setting-out coordinates, 50
  - Disturbances in comfort, 42
    - Troubleshooting, 42
- E**
  - Electrical cabinet, 21
  - Electrical circuit diagram, 64
  - Electrical connections, 24
    - Addressing via multi-heat pump operation, 26
    - Connecting accessories, 33
    - Connections, 27
    - General, 24
    - Optional connections, 30
    - Power connection, 27
  - Energy labelling, 59
    - Data for energy efficiency of the package, 59
    - Information sheet, 59
    - Technical documentation, 60
  - Energy rating, average climate, 54
  - Environmental information, 6
- F**
  - F2120 does not communicate, 42
  - F2120 is not operational, 42
  - Filling and venting the heating medium system, 34
- H**
  - Heat pump settings – Menu 7.3.2, 40
  - High room temperature, 43
- I**
  - Ice build-up in the fan, grille and/or fan cone, 43
  - Important information, 4
    - Compatible indoor modules (VVM) and control modules (SMO), 8
    - Control module, 9
    - Environmental information, 6
    - Indoor module, 9
    - Inspection of the installation, 7
    - Recovery, 6
    - Safety information, 4
    - Serial number, 6
  - Indoor module, 9
  - Inspection of the installation, 7
  - Installation area, 14



**L**

Large amount of water below F2120, 43  
LED status, 37  
Low hot water temperature or no hot water, 42  
Low room temperature, 42

**M**

Marking, 4  
Master control, 38

**O**

Optional connections, 30  
    Communication, 30

**P**

Pipe connections, 22  
    Charge pump, 22  
    General, 22  
    Pipe coupling heating medium circuit, 22  
    Pressure drop, heating medium side, 23  
    Water volumes, 22  
Pipe coupling heating medium circuit, 22  
Power connection, 27  
Preparations, 34  
Pressure drop, heating medium side, 23

**R**

Readjusting, heating medium side, 35  
Recovery, 6  
Removing the side cover, 16

**S**

Safety information, 4  
    Marking, 4  
    Safety precautions, 4  
    Symbols, 4  
Safety precautions, 4  
Sensor placement, 44  
Serial number, 6  
Sound levels, 51  
Start-up and inspection, 35  
Supplied components, 15  
Symbols, 4

**T**

Technical data, 50  
    Dimensions and setting-out coordinates, 50  
    Electrical circuit diagram, 64  
    Energy rating, average climate, 54  
    Sound pressure levels, 51  
    Technical Data, 52  
Technical Data, 52  
The heat pump design, 17  
    Component list electrical cabinet, 21  
    Component location electrical cabinet, 21  
    Component locations, 17  
    List of components, 17, 20  
Transport and storage, 10  
Troubleshooting, 42  
    Basic actions, 42  
    F2120 does not communicate, 42  
    F2120 is not operational, 42

High room temperature, 43  
Ice build-up in the fan, grille and/or fan cone, 43  
Large amount of water below F2120, 43  
Low hot water temperature or no hot water, 42  
Low room temperature, 42  
Sensor placement, 44



## Contact information

### *AUSTRIA*

KNV Energietechnik GmbH  
Gahberggasse 11, 4861 Schörfling  
Tel: +43 (0)7662 8963-0  
mail@knv.at  
knv.at

### *CZECH REPUBLIC*

Družstevní závody Dražice - strojírna  
s.r.o.  
Dražice 69, 29471 Benátky n. Jiz.  
Tel: +420 326 373 801  
nibe@nibe.cz  
nibe.cz

### *DENMARK*

Vølund Varmeteknik A/S  
Industrivej Nord 7B, 7400 Herning  
Tel: +45 97 17 20 33  
info@volundvt.dk  
volundvt.dk

### *FINLAND*

NIBE Energy Systems Oy  
Juurakkotie 3, 01510 Vantaa  
Tel: +358 (0)9 274 6970  
info@nibe.fi  
nibe.fi

### *FRANCE*

NIBE Energy Systems France SAS  
Zone industrielle RD 28  
Rue du Pou du Ciel, 01600 Reyrieux  
Tél: 04 74 00 92 92  
info@nibe.fr  
nibe.fr

### *GERMANY*

NIBE Systemtechnik GmbH  
Am Reiherpfahl 3, 29223 Celle  
Tel: +49 (0)5141 75 46 -0  
info@nibe.de  
nibe.de

### *GREAT BRITAIN*

NIBE Energy Systems Ltd  
3C Broom Business Park,  
Bridge Way, S41 9QG Chesterfield  
Tel: +44 (0)845 095 1200  
info@nibe.co.uk  
nibe.co.uk

### *NETHERLANDS*

NIBE Energietechnik B.V.  
Energieweg 31, 4906 CG Oosterhout  
Tel: +31 (0)168 47 77 22  
info@nibenl.nl  
nibenl.nl

### *NORWAY*

ABK-Qviller AS  
Brobekkveien 80, 0582 Oslo  
Tel: (+47) 23 17 05 20  
post@abkqviller.no  
nibe.no

### *POLAND*

NIBE-BIAWAR Sp. z o.o.  
Al. Jana Pawla II 57, 15-703 Bialystok  
Tel: +48 (0)85 66 28 490  
biawar.com.pl

### *RUSSIA*

EVAN  
bld. 8, Yuliusa Fuchika str.  
603024 Nizhny Novgorod  
Tel: +7 831 419 57 06  
kuzmin@evan.ru  
nibe-evan.ru

### *SWEDEN*

NIBE Energy Systems  
Box 14  
Hannabadsvägen 5, 285 21 Markaryd  
Tel: +46 (0)433-27 3000  
info@nibe.se  
nibe.se

### *SWITZERLAND*

NIBE Wärmetechnik c/o ait Schweiz  
AG  
Industriepark, CH-6246 Altishofen  
Tel. +41 (0)58 252 21 00  
info@nibe.ch  
nibe.ch

For countries not mentioned in this list, contact NIBE Sweden or check [nibe.eu](http://nibe.eu) for more information.

NIBE Energy Systems  
Hannabadsvägen 5  
Box 14  
SE-285 21 Markaryd  
info@nibe.se  
nibe.eu

IHB EN 2018-1 531768

This manual is a publication from NIBE Energy Systems. All product illustrations, facts and data are based on the available information at the time of the publication's approval. NIBE Energy Systems makes reservations for any factual or printing errors in this manual.

©2020 NIBE ENERGY SYSTEMS



531768