

Ground source heat pump

NIBE F1255 *UK 1x230V*



Quick guide

Navigation

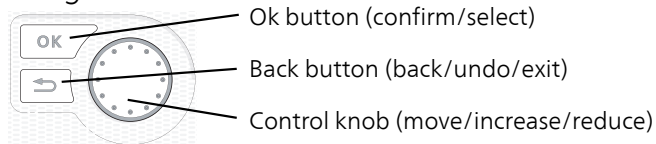

A detailed explanation of the button functions can be found on page 38.

How to scroll through menus and make different settings is described on page 41.

Set the indoor climate

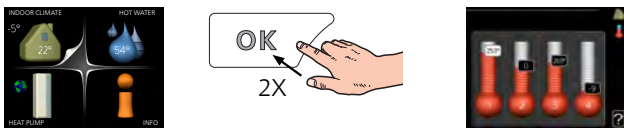

The mode for setting the indoor temperature is accessed by pressing the OK button twice, when in the start mode in the main menu.

Increase hot water volume



To temporarily increase the amount of hot water, first turn the control knob to mark menu 2 (water droplet) and then press the OK button twice.

Table of Contents

1	<i>Important information</i>	4	Filling and venting	32
	Safety information	4	Start-up and inspection	33
	Symbols	4	Setting the heating curve	35
	Marking	4		
	Serial number	5	7 <i>Control - Introduction</i>	38
	Recovery	5	Display unit	38
	Environmental information	5	Menu system	39
	Country specific information	6	8 <i>Control - Menus</i>	43
	Inspection of the installation	7	Menu 1 - INDOOR CLIMATE	43
2	<i>Delivery and handling</i>	8	Menu 2 - HOT WATER	43
	Transport	8	Menu 3 - INFO	44
	Assembly	8	Menu 4 - HEAT PUMP	44
	Supplied components	9	Menu 5 - SERVICE	45
	Removing the covers	9	9 <i>Service</i>	57
	Removing parts of the insulation	10	Maintenance	57
			Service actions	58
3	<i>The heat pump design</i>	11	10 <i>Disturbances in comfort</i>	64
	General	11	Manage alarm	64
	Distribution boxes	13	Troubleshooting	64
	Cooling section (EP14)	14	11 <i>Accessories</i>	67
4	<i>Pipe connections</i>	16	12 <i>Technical data</i>	69
	General	16	Dimensions and setting-out coordinates	69
	Dimensions and pipe connections	19	Electrical data	70
	Brine side	19	Technical specifications	71
	Heating medium side	20	Energy labelling	75
	Cold and hot water	20		
	Docking alternatives	20	<i>Item register</i>	78
5	<i>Electrical connections</i>	23	<i>Contact information</i>	87
	General	23		
	Connections	25		
	Settings	26		
	Optional connections	27		
	Connecting accessories	30		
6	<i>Commissioning and adjusting</i>	32		
	Preparations	32		

1 Important information

Safety information

This manual describes installation and service procedures for implementation by specialists.

The manual must be left with the customer.

This appliance can be used by children aged from 8 years and above and persons with reduced physical, sensory or mental capabilities or lack of experience and knowledge if they have been given supervision or instruction concerning use of the appliance in a safe way and understand the hazards involved. Children shall not play with the appliance. Cleaning and user maintenance shall not be made by children without supervision.

Rights to make any design or technical modifications are reserved.

©NIBE 2020.

Water may drip from the safety valve's overflow pipe. The entire length of the overflow water pipe must be routed to a suitable drain and be inclined to prevent water pockets, and must also be frost-proof. The overflow pipe must be at least the same size as the safety valve. The overflow pipe must be visible and its mouth must be open and not located close to electrical components.

F1255 must be installed via an isolator switch. The cable area has to be dimensioned based on the fuse rating used.

Symbols



NOTE

This symbol indicates danger to person or machine .



Caution

This symbol indicates important information about what you should consider when installing or servicing the installation.



TIP

This symbol indicates tips on how to facilitate using the product.

Marking

CE The CE mark is obligatory for most products sold in the EU, regardless of where they are made.

IP21 Classification of enclosure of electro-technical equipment.



Danger to person or machine.



Read the User Manual.

Serial number

The serial number can be found at the bottom right of the front cover, in the info menu (menu 3.1) and on the type plate (PZ1).

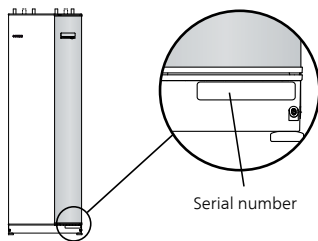

Caution

You need the product's ((14 digit) serial number for servicing and support.

Recovery



Leave the disposal of the packaging to the installer who installed the product or to special waste stations.

Do not dispose of used products with normal household waste. It must be disposed of at a special waste station or dealer who provides this type of service.

Improper disposal of the product by the user results in administrative penalties in accordance with current legislation.

Environmental information

F-GAS REGULATION (EU) NO. 517/2014

This unit contains a fluorinated greenhouse gas that is covered by the Kyoto agreement.

The equipment contains R407C, a fluorinated greenhouse gas with a GWP value (Global Warming Potential) of 1,774. Do not release R407C into the atmosphere.

Country specific information

UNITED KINGDOM

This installation is subject to building regulation approval, notify the local Authority of intention to install.

Use only manufacturer's recommended replacement parts.

For more information see nibe.co.uk.



Benchmark places responsibilities on both manufacturers and installers. The purpose is to ensure that customers are provided with the correct equipment for their needs, that it is installed, commissioned and serviced in accordance with the manufacturers instructions by competent persons and that it meets the requirements of the appropriate Building Regulations. The Benchmark Checklist can be used to demonstrate compliance with Building Regulations and should be provided to the customer for future reference.

Installers are required to carry out the installation, commissioning and servicing work in accordance with the Benchmark Code of practice which is available from the Heating and Hotwater Industry Council who manage and promote the Scheme. Visit centralheating.co.uk for information.

Warranty and insurance information

Thank you for installing a new NIBE heat pump in your home.

NIBE heat pumps are manufactured in Sweden to the very highest standard so we are pleased to offer our customers a comprehensive guarantee.

The product is guaranteed for 24 months for parts and labour from the date of installation or 33 months from the date of manufacture, whichever is the shorter.

The NIBE guarantee is based on the unit being installed and commissioned by a NIBE accredited installer, serviced every year and the Benchmark documents completed. Where this condition is not met, any chargeable spare parts or components issued within the applicable guarantee period still benefit from a 12 month warranty from the date of issue by the manufacturer.

We recommend the installer completes and returns as soon as possible, your guarantee registration card or completes the guarantee form on the NIBE website www.nibe.co.uk

Electrical Supply

The heat pump must be permanently connected to a 230V ac 50Hz supply.

All system components shall be of an approved type and all wiring to current I.E.E wiring regulations.

External wiring must be correctly earthed, polarised and in accordance with the relevant standards: Currently this is BS 7671.

Domestic Hot Water

All domestic hot water circuits, connections and fittings must be in accordance with the relevant standards and water supply regulations. It should also be in accordance with the relevant requirements of the Local Authority and the Building Regulations relevant to the location of installation.

BS 8558:2015 Services supplying water for domestic use within buildings and their cartilages.

Water Supply (Water Fitting) Regulations 1999 or The Water Bylaws 2000 (Scotland).

Heating System

The installation of the heat pump should follow best practice as covered in the following:

BS 5449 Forced circulation hot water central heating systems for domestic premises.

BS 15450 Heating systems in buildings – Design of heat pump heating systems.

Inspection of the installation

Current regulations require the heating installation to be inspected before it is commissioned. The inspection must be carried out by a suitably qualified person.

In addition, fill in the page for the installation data in the User Manual.

✓	Description	Notes	Signature	Date
Brine (page 19)				
	System flushed			
	System vented			
	Antifreeze			
	Level/Expansion vessel			
	Filterball (particle filter)			
	Safety valve			
	Shut off valves			
	Circulation pump setting			
Heating medium (page 20)				
	System flushed			
	System vented			
	Expansion vessel			
	Filterball (particle filter)			
	Safety valve			
	Shut off valves			
	Circulation pump setting			
Electricity (page 23)				
	Connections			
	Main voltage			
	Phase voltage			
	Fuses heat pump			
	Fuses property			
	Outside sensor			
	Room sensor			
	Safety breaker			
	Earth circuit-breaker			
	Setting of emergency mode thermostat			
Miscellaneous				
	Warranty			
	Benchmark checklist			

2 Delivery and handling

Transport

F1255 should be transported and stored vertically in a dry place. When being moved into a building, F1255 may be leant back 45°.

Ensure that F1255 has not been damaged during transport.



Caution

The product can be tail heavy.

Remove the outer panels in order to protect them when moving in confined spaces inside buildings.

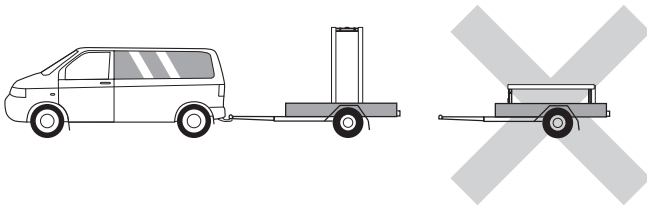

EXTRACTING THE COOLING MODULE

To simplify transport and service, the heat pump can be separated by pulling the cooling module out from the cabinet.

See page 60 for instructions about the separation.

Assembly

- Place F1255 on a solid foundation indoors that can take the heat pump's weight. Use the product's adjustable feet to obtain a horizontal and stable set-up.

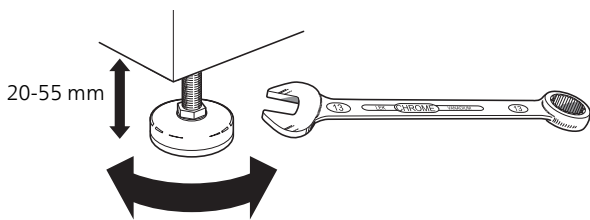

- Because water comes from F1255, the area where the heating pump is located must be equipped with floor drainage.

- Install with its back to an outside wall, ideally in a room where noise does not matter, in order to eliminate noise problems. If this is not possible, avoid placing it against a wall behind a bedroom or other room where noise may be a problem.
- Wherever the unit is located, walls to sound sensitive rooms should be fitted with sound insulation.
- Route pipes so they are not fixed to an internal wall that backs on to a bedroom or living room.

INSTALLATION AREA

Leave a free space of 800 mm in front of the product. Approx. 50 mm free space is required on each side, to remove the side panels (see image). The panels do not need to be removed during service. All service on F1255 can be carried out from the front. Leave space between the heat pump and the wall behind (and any routing of supply cables and pipes) to reduce the risk of any vibration being propagated.

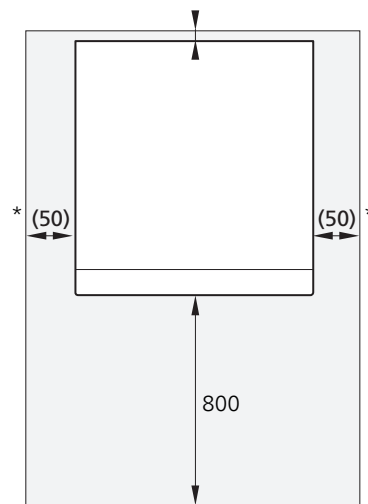

* A normal installation needs 300 – 400 mm (any side) for connection equipment, valves and electrical equipment.

Supplied components Removing the covers

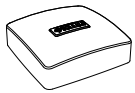

Outside sensor
1 x



Room sensor
1 x

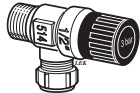

Safety valve
0.3 MPa (3 bar)
1 x



O-rings
8 x

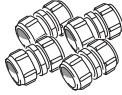

Compression ring
couplings
6 kW
6 kW
2 x (ø28 x G25)
2 x (ø22 x G20)
12 kW
12 kW
4 x (ø28 x G25)



Filterball
6 kW
1 x G1
1 x G3/4
12 kW
1 x G1
1 x G1 1/4

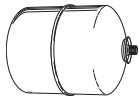

Expansion vessel
domestic water
(with holder (CM4,
enclosed separ-
ately)
1 x



Armoured hose
(expansion ves-
sel)
1 x



Filler hose (WN1)
1 x



Pressure reduc-
tion valve (QN17)
1 x



Filling valves for
the climate sys-
tem ((QM11) and
(QM13))
2 x



Expansion relief
valve (FL1)
1 x



Tundish (WM3)
2 x

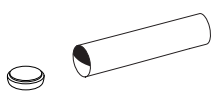

Pipe and plug,
22 mm

LOCATION

The kit of supplied items is placed in packaging on top of the heat pump.

FRONT COVER

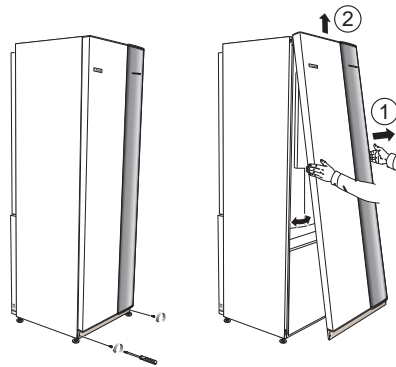

1. Remove the screws from the lower edge of the front panel.
2. Lift the panel out at the bottom edge and up.

SIDE COVERS

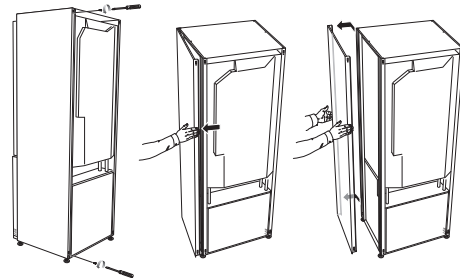

The side covers can be removed to facilitate the installation.

1. Remove the screws from the upper and lower edges.
2. Twist the cover slightly outward.
3. Move the hatch outwards and backwards.
4. Assembly takes place in the reverse order.

Removing parts of the insulation

Parts of the insulation can be removed to facilitate the installation.

INSULATION, TOP

1. Disconnect the cable from the motor and remove the motor from the shuttle valve as illustrated.

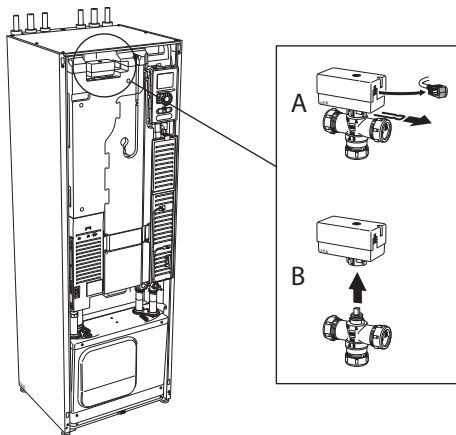

2. Grip the handle and pull straight out as illustrated.

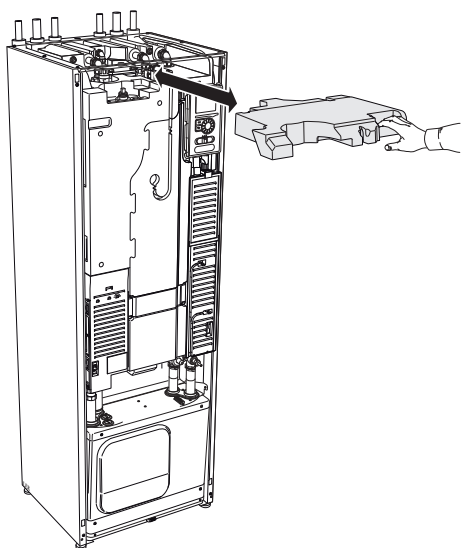

INSULATION, IMMERSION HEATER



NOTE

Electrical installation and service must be carried out under the supervision of a qualified electrician. Electrical installation and wiring must be carried out in accordance with the stipulations in force.

1. Remove the cover for the junction box according to the description on page 24.
2. Grip the handle and pull the insulation carefully towards you as illustrated.

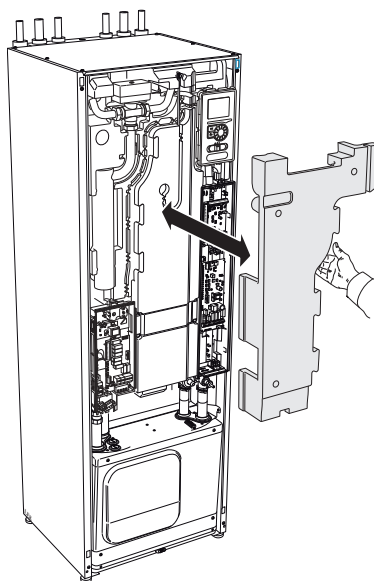

3 The heat pump design

General

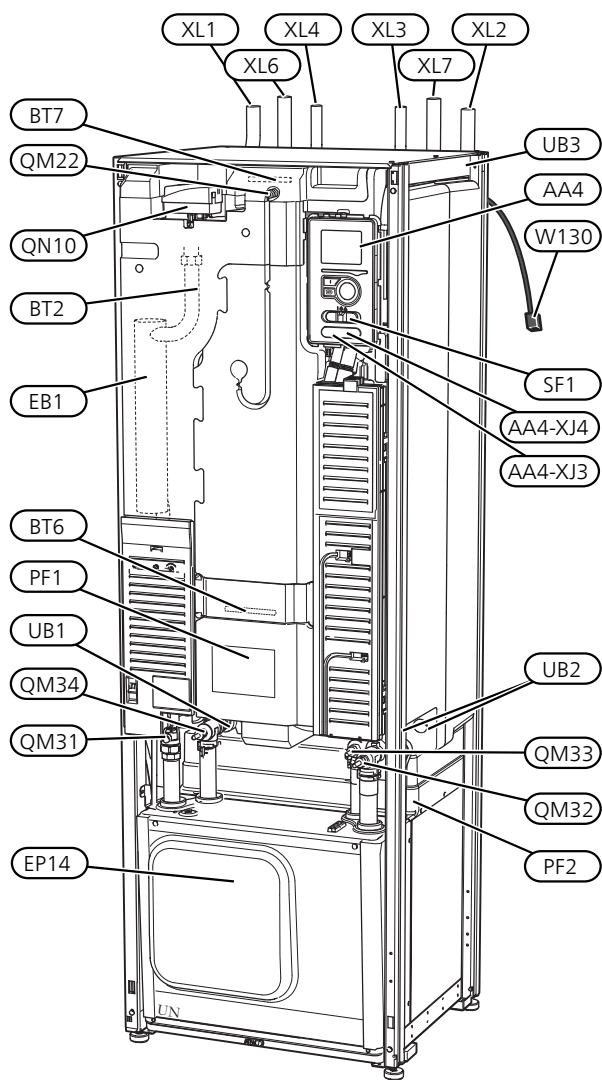

VIEW FROM ABOVE

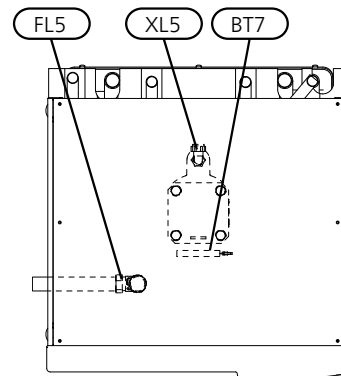

PIPE CONNECTIONS

XL1	Connection, heating medium flow
XL2	Connection, heating medium return
XL3	Connection, cold water
XL4	Connection, hot water
XL5	Connection, HWC
XL6	Connection, brine in
XL7	Connection, brine out

HVAC COMPONENTS

FL5	T&P valve
QM22	Venting, coil
QM31	Shut-off valve, heating medium flow
QM32	Shut off valve, heating medium return
QM33	Shut off valve, brine out
QM34	Shut-off valve, brine in
QN10	Shuttle valve, climate system/water heater

SENSORS ETC.

BT1	Outdoor temperature sensor*
BT2	Temperature sensors, heating medium flow
BT6	Temperature sensor, hot water charging
BT7	Temperature sensor, hot water top

* Not illustrated

ELECTRICAL COMPONENTS

AA4	Display unit
	AA4-XJ3 USB socket
	AA4-XJ4 Service outlet (No function)
EB1	Immersion heater
SF1	Switch
W130	Network cable for NIBE Uplink

MISCELLANEOUS

EP14	Cooling section
PF1	Rating plate
PF2	Type plate, cooling section
UB1	Cable gland, incoming electricity
UB2	Cable gland
UB3	Cable gland, rear side, sensor

Designations according to standard EN 81346-2.

Distribution boxes

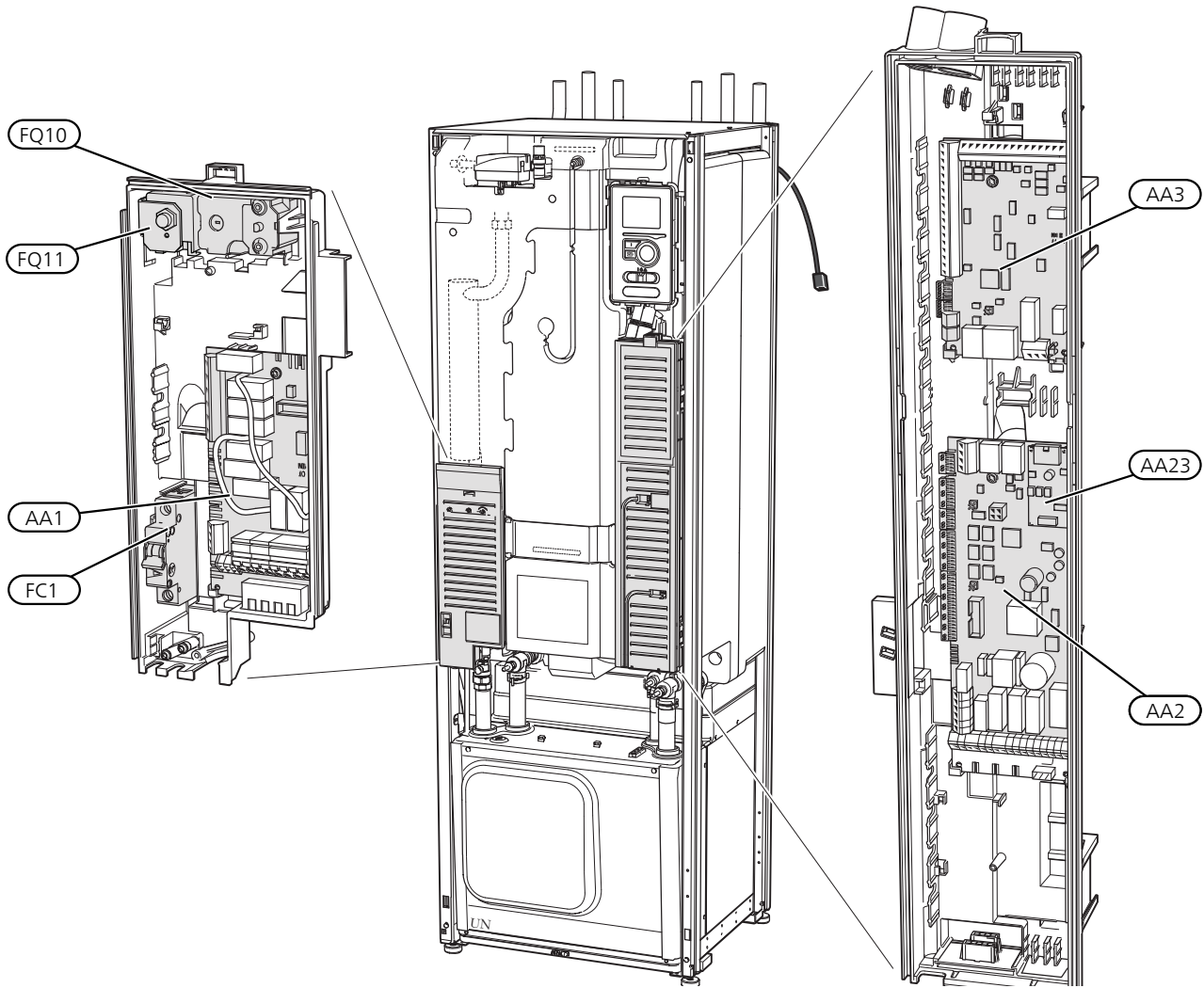

ELECTRICAL COMPONENTS

- AA1 Immersion heater card
- AA2 Base card
- AA3 Input circuit board
- AA23 Communication board
- FC1 Miniature circuit-breaker
- FQ10 Temperature limiter/Emergency mode thermostat
- FQ11 Temperature limiter, compressor

Cooling section (EP14)

6 kW

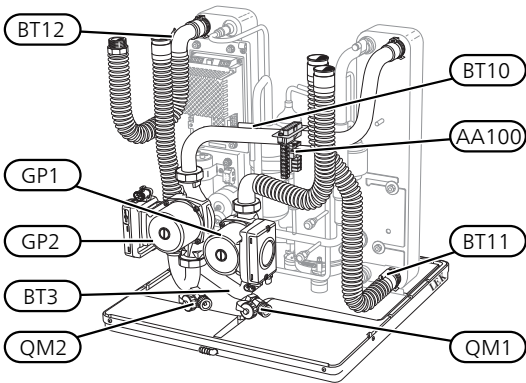

12 kW

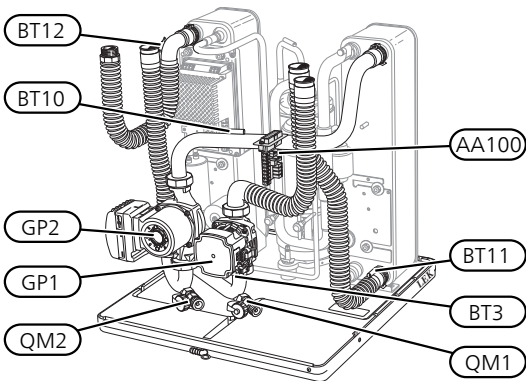

6 kW

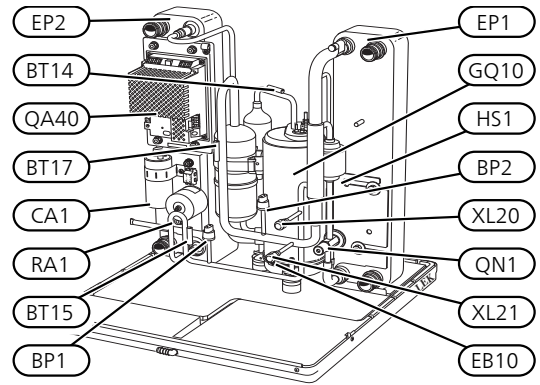

12 kW

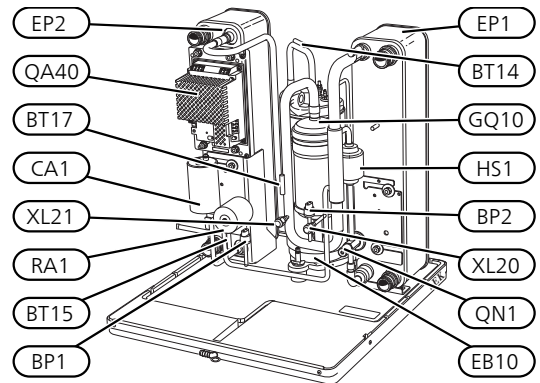

PIPE CONNECTIONS

- XL20 Service connection, high pressure
- XL21 Service connection, low pressure

HVAC COMPONENTS

- GP1 Circulation pump
- GP2 Brine pump
- QM1 Drainage, climate system
- QM2 Draining, brine side

SENSORS ETC.

- BP1 High pressure pressostat
- BP2 Low pressure pressostat
- BT3 Temperature sensors, heating medium return
- BT10 Temperature sensor, brine in
- BT11 Temperature sensor, brine out
- BT12 Temperature sensor, condenser supply line
- BT14 Temperature sensor, hot gas
- BT15 Temperature sensor, fluid pipe
- BT17 Temperature sensor, suction gas

ELECTRICAL COMPONENTS

- AA100 Joint card
- CA1 Capacitor
- EB10 Compressor heater
- QA40 Inverter
- RA1 Choke

COOLING COMPONENTS

- EP1 Evaporator
- EP2 Condenser
- GQ10 Compressor
- HS1 Drying filter
- QN1 Expansion valve

4 Pipe connections

General

Pipe installation must be carried out in accordance with current norms and directives. F1255 can operate with a return temperature of up to 58 °C and an outgoing temperature from the heat pump of 70 (65 °C with only the compressor).

F1255 is not equipped with external shut off valves; these must be installed to facilitate any future servicing.



Caution

Ensure that incoming water is clean. When using a private well, it may be necessary to supplement with an extra water filter.



Caution

Any high points in the climate system, must be equipped with air vents.



NOTE

The pipe systems need to be flushed out before the heat pump is connected so debris cannot damage component parts.



NOTE

Water may drip from the safety valve's overflow pipe. The entire length of the overflow water pipe must be routed to a suitable drain and be inclined to prevent water pockets, and must also be frost-proof. The overflow pipe must be at least the same size as the safety valve. The overflow pipe must be visible and its mouth must be open and not located close to electrical components.



NOTE

This installation is subject to building regulation approval, notify the local Authority of intention to install.



NOTE

Use only manufacturer's recommended replacement parts.

Waste water from the collection tray and from safety valves is led via an unpressurised overflow pipe to the drain, so hot water splashes cannot cause harm.

The mouth of the overflow pipe must be visible and not placed close to electrical components. In addition, the mouth of the overflow pipe (tundish), drain valves and motorised valves should also be positioned well away from all electrical components. This is the only permitted use of unpressurised overflow pipes. Overflow pipes from tundish (WM1) connected to the expansion relief valve (FL1) must also be connected to the drain in the same way.

The connection for the T&P valve (XL29) must not be used for any other purpose. Valves may not be positioned between the T&P valve (FL5) and the water heater.

Overflow pipes from tundish must be routed with a fall and be at least 300 mm long, before bends or angles in the pipework (see image) and must also be frost-proof.

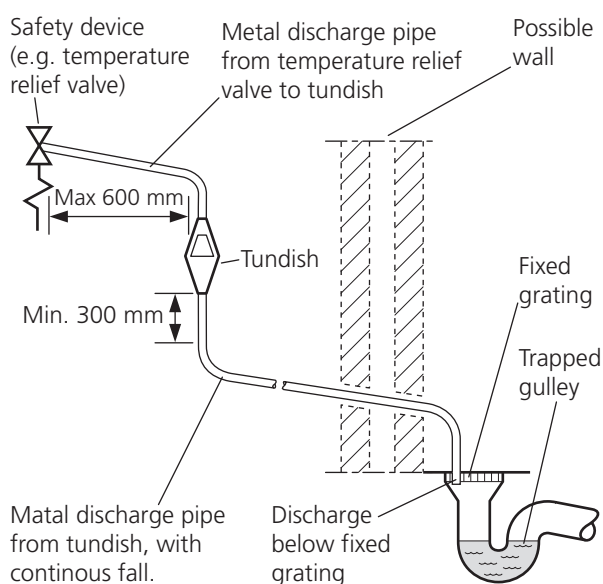

If the vertical section, 300 mm, is difficult to fill, there is a vertically adjustable bracket as an accessory.

<i>Valve outlet size</i>	<i>Minimum size of discharge pipe</i>	<i>Minimum size of discharge pipe from tundish</i>	<i>Maximum resistance allowed, expressed as a length of straight pipe (i.e. no elbows or bends)</i>	<i>Resistance created by each elbow or bend</i>
G1/2	15 mm	22 mm	up to 9 m	0.8 mm
G1/2	15 mm	28 mm	up to 18 m	1.0 mm
G1/2	15 mm	35 mm	up to 27 m	1.4 mm
<G3>/4	22 mm	28 mm	up to 9 m	1.0 mm
<G3>/4	22 mm	35 mm	up to 18 m	1.4 mm
<G3>/4	22 mm	42 mm	up to 27 m	1.7 mm
G1	28 mm	35 mm	up to 9 m	1.4 mm
G1	28 mm	42 mm	up to 18 m	1.7 mm
G1	28 mm	54 mm	up to 27 m	2.3 mm

HARD WATER AREAS

There should not normally be any problem installing F1255 in hard water areas, as the operating temperature is 50-60°C.

CLEANING THE CLIMATE SYSTEM

When the water heater and the climate system have been filled with water, F1255 must operate at maximum normal temperature for at least one hour. Thereafter the system must be drained of water and refilled.

Before installing the heat pump in an existing system, it is important that the system is properly flushed through.

Even if the heat pump is to be installed in a new system, the heat pump and system should be flushed.



NOTE

Ensure that cleaning agent has been removed from the entire system before adding inhibitor.

After flushing an inhibitor should be used for long-term anti-corrosion protection.

NIBE Energy Systems Limited recommends water treatments (supplied by e.g. Fernox and Sentinel) specifically designed for heat pumps.

SYMBOL KEY

SYSTEM DIAGRAM

F1255 consists of a heat pump, water heater, electrical module, circulation pumps and a control system. F1255 is connected to the brine and heating medium circuits.

In the heat pump evaporator, the brine (water mixed with anti-freeze, glycol or ethanol) releases its energy to the refrigerant, which is vaporised in order to be compressed in the compressor. The refrigerant, of which the temperature has now been raised, is passed to the condenser where it gives off its energy to the heating medium circuit and, if necessary, to the water heater. If there is a greater need for heating/hot water than the compressor can provide there is an integrated immersion heater.

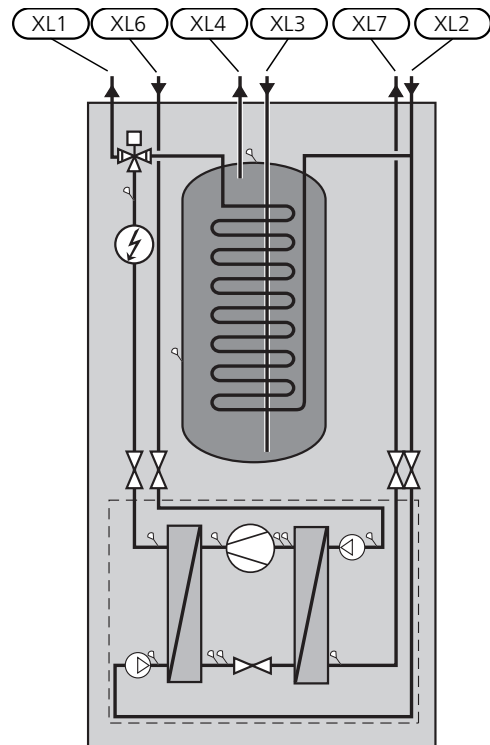

XL1	Connection, heating medium flow
XL2	Connection, heating medium return
XL3	Connection, cold water
XL4	Connection, hot water
XL6	Connection, brine in
XL7	Connection, brine out

Dimensions and pipe connections

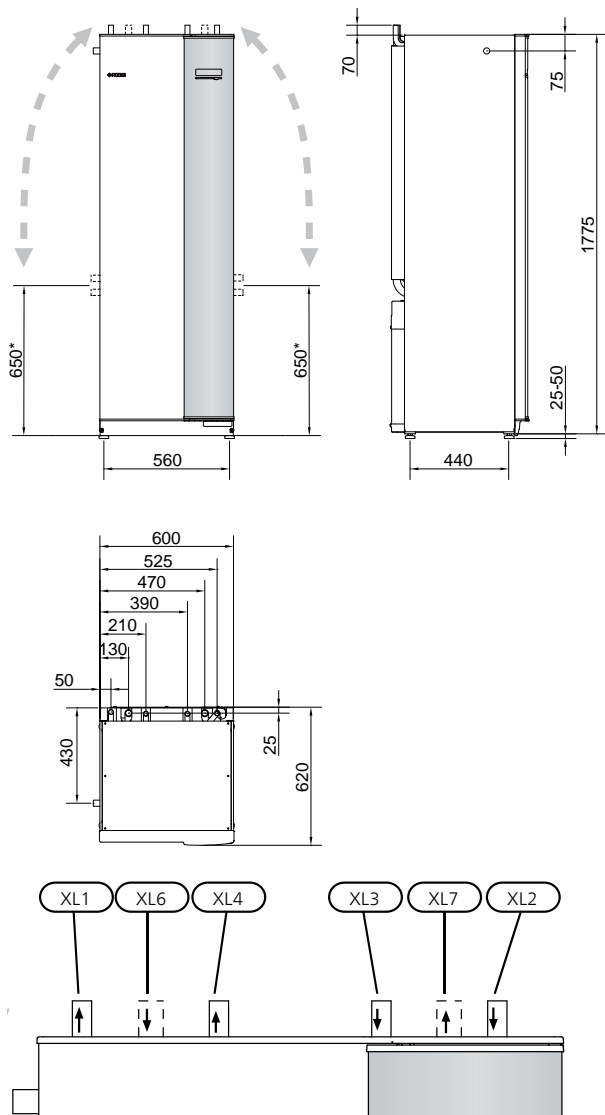

PIPE DIMENSIONS

Connection		6 kW	12 kW
(XL1)/(XL2) Heating medium flow/return ext. Ø	(mm)	22	28
(XL3)/(XL4) Cold/hot water Ø	(mm)	22	
(XL6)/(XL7) Brine in/out ext. Ø	(mm)	28	

* Can be angled for side connection.

Brine side

COLLECTOR



Caution

The length of the collector hose varies depending on the rock/soil conditions, climate zone and on the climate system (radiators or under-floor heating) and the heating requirement of the building. Each installation must be sized individually.

Max. length per coil for the collector should not exceed 400 m.

In those cases where it is necessary to have several collectors, these should be connected in parallel with the possibility for adjusting the flow of the relevant coil.

For surface soil heat, the hose should be buried at a depth determined by local conditions and the distance between the hoses should be at least 1 metre.

For several bore holes, the distance between the holes must be determined according to local conditions.

Ensure the collector hose rises constantly towards the heat pump to avoid air pockets. If this is not possible, airvents should be used.

Because the temperature of the brine system can fall below 0 °C, it must be protected against freezing down to -15 °C. When making the volume calculation, use 1 litres of ready mixed brine per metre of collector hose (applies when using PEM-hose 40x2.4 PN 6.3) as a guide value.

Anti freeze must be mixed according to manufacturer's instructions to ensure frost protection and should be checked using a refractometer.



NOTE

Ensure that cleaning agent has been removed from the entire system before the anti-freeze is added.

NIBE Energy Systems Limited recommends water treatments (supplied by e.g. Fernox and Sentinel) specifically designed for heat pumps.

SIDE CONNECTION

It is possible to angle the brine connections, for connection to the side instead of top connection.

To angle out a connection:

1. Disconnect the pipe at the top connection.
2. Angle the pipe in the desired direction.
3. If necessary, cut the pipe to the desired length.

CONNECTING THE BRINE SIDE

- Insulate all indoor brine pipes against condensation.
- The system must be fitted with an expansion vessel (CM3), pressure gauge (BP6) and the enclosed safety valve (FL3).
- Install a shut off valve for outgoing brine as close to the heat pump as possible.
- Fit the enclosed filterball on the incoming brine.



TIP

If filling connection KB25/KB32 is used, the enclosed filterball does not need to be fitted.

In the case of connection to an open groundwater system, an intermediate frost-protected circuit must be provided, because of the risk of dirt and freezing in the evaporator. This requires an extra heat exchanger.

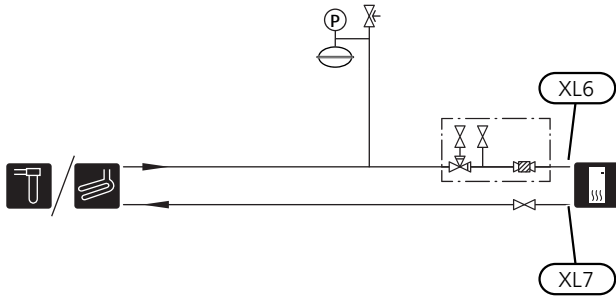

Heating medium side

CONNECTING THE CLIMATE SYSTEM

A climate system is a system that regulates indoor comfort with the help of the control system in F1255 and for example radiators, underfloor heating/cooling, fan convectors etc.

- Install all necessary safety devices, shut-off valves (as close to the heat pump as possible) and the enclosed filterball.
- Fit safety valve on heating medium return as illustrated. Recommended opening pressure is 0.25 MPa (2.5 bar). For information about max opening pressure, see technical specifications.
- When connecting to a system with thermostats on all radiators (or underfloor heating coils), either a bypass valve must be fitted or some of the thermostats must be removed to ensure there is sufficient flow.

Before installing the heat pump in an existing system, it is important that the system is properly flushed through.

Even if the heat pump is to be installed in a new system, the heat pump and system should be flushed.



NOTE

Ensure that cleaning agent has been removed from the entire system before adding inhibitor.

After flushing an inhibitor should be used for long-term anti-corrosion protection.

NIBE Energy Systems Limited recommends water treatments (supplied by e.g. Fernox and Sentinel) specifically designed for heat pumps.

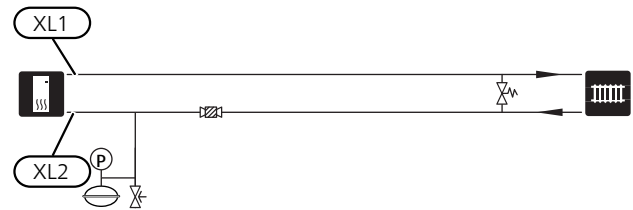

Cold and hot water

CONNECTING COLD AND HOT WATER

- Fit shut-off valve and non-return valve, as well as the enclosed expansion relief valve (FL1), pressure reduction valve (QN17), expansion vessel (CM4) and tundish (WM3) as illustrated.
- The expansion vessel (CM4) accommodates expansion that results from heating the water inside the unit. The expansion vessel must be connected between the expansion relief valve (FL1) and the water heater. The location of the expansion vessel should allow access to recharge the pressure as and when necessary.
- Stop temperature for hot water must be at least 60°C.
- A mixing valve must be installed when the factory setting for hot water is changed. National regulations must be observed.
- The setting for hot water is made in menu 5.1.1 (page 46).

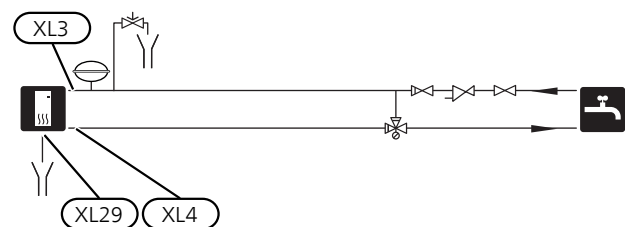

Docking alternatives

F1255 can be connected in several different ways, some of which are shown below.

Further option information is available at www.nibe.co.uk and in the respective assembly instruction for the accessory used. See page 67 for a list of accessories that can be used with F1255.

BUFFER VESSEL

If the climate system volume is too small for the heat pump output, the radiator system can be supplemented with a buffer vessel, for example NIBE UKV.

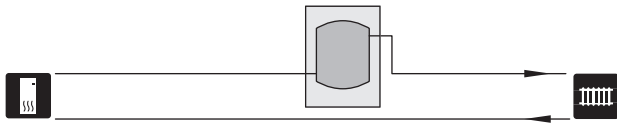

EXTRA HOT WATER HEATERS

The system should be supplemented with an extra water heater, if a large bath tub or other significant consumer of hot water is installed.

Water heater with immersion heater

If it is possible to use a water heater with an immersion heater, connect it as illustrated below.

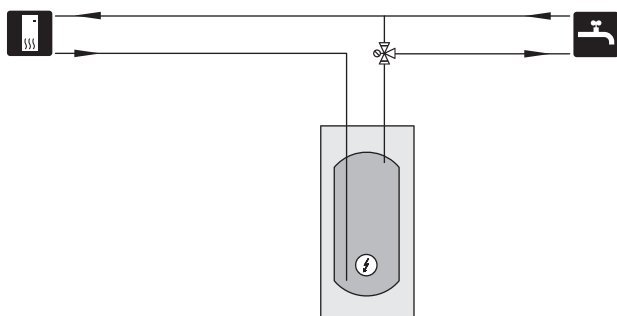

GROUND WATER SYSTEM

An intermediate heat exchanger is used to protect the heat pump's exchanger from dirt. The water is released into a buried filtration unit or a drilled well. See page 30 for more information about connecting a ground water pump.

If this docking alternative is used, "min. brine out" in menu 5.1.7 "br pmp al set." must be changed to a suitable value to prevent freezing of the heat exchanger.

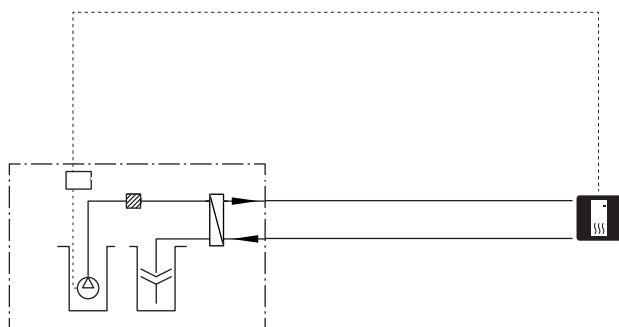

VENTILATION RECOVERY

The installation can be supplemented with the exhaust air module NIBE FLM to provide ventilation recovery.

- Pipes and other cold surfaces must be insulated with diffusion-proof material to prevent condensation.

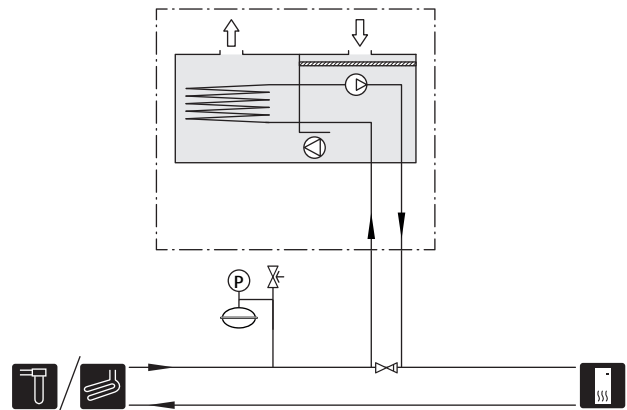

FREE COOLING

The accessory PCS 44 allows the connection of passive cooling, for example with fan coils. The cooling system is connected to the heat pump brine circuit, whereby cooling is supplied from the collector via a circulation pump and shunt valve.

- Pipes and other cold surfaces must be insulated with diffusion-proof material to prevent condensation.
- Where the cooling demand is high, fan convectors with drip trays and drain connection are needed.

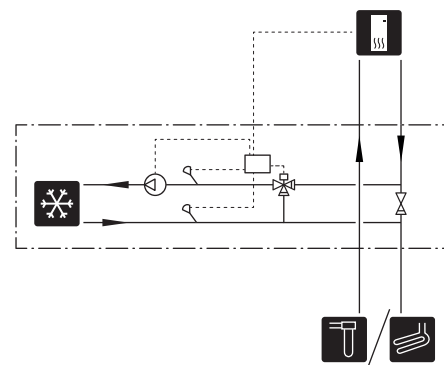

TWO OR MORE CLIMATE SYSTEMS

In buildings with several climate systems that require different supply temperatures, the accessory ECS 40/ECS 41 can be connected. A shunt valve then lowers the temperature to the underfloor heating system, for example.

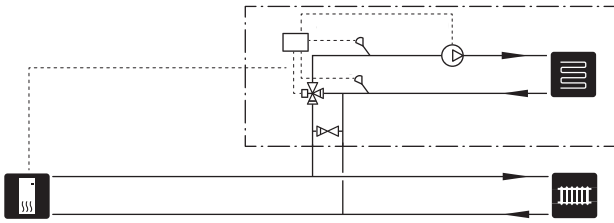

POOL

With the POOL 40 accessory, you can heat the pool with your heat pump.

During pool heating, the heating medium circulates between the F1255 and the pool exchanger using the heat pump's internal circulation pump.

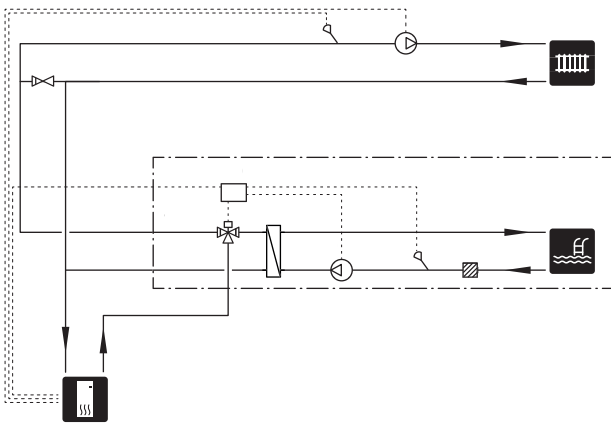

5 Electrical connections

General

All electrical equipment, except the outdoor sensors, room sensors and the current sensors are ready connected at the factory.

- Disconnect the heat pump before insulation testing the house wiring.
- If the building is equipped with an earth-fault breaker, F1255 should be equipped with a separate one.
- If a miniature circuit breaker is used this should have at least motor characteristic "C". See page 71 for fuse size.
- Electrical wiring diagrams for the heat pump, see separate installation handbook for electrical wiring diagrams.
- Communication and sensor cables to external connections must not be laid close to high current cables.
- The minimum area of communication and sensor cables to external connections must be 0.5 mm² up to 50 m, for example EKKX or LiYY or equivalent.
- When cable routing in F1255, cable grommets (e.g. UB1-UB3, marked in image) must be used. In UB1-UB3 the cables are inserted through the heat pump from the back to the front.



NOTE

The switch (SF1) must not be moved to "I" or "△" until the boiler has been filled with water. Components in the product could be damaged.



NOTE

Electrical installation and service must be carried out under the supervision of a qualified electrician. Cut the current with the circuit breaker before carrying out any servicing. Electrical installation and wiring must be carried out in accordance with the stipulations in force.



NOTE

Check the connections, main voltage and phase voltage before the machine is started, to prevent damage to the heat pump electronics.

MINIATURE CIRCUIT-BREAKER

The heat pump operating circuit and some of its internal components are internally fused by a miniature circuit breaker (FC1).

TEMPERATURE LIMITER

The temperature limiter (FQ10) cuts the power to the electric additional heat if the temperature exceeds 89°C and is reset manually.

Resetting

The temperature limiter (FQ10) is accessed behind the front cover. Reset the temperature limiter by pressing the button (FQ10-SF2) using a small screwdriver.

TEMPERATURE LIMITER, COMPRESSOR

The temperature limiter (FQ11) cuts the power supply to the soft-start, if the temperature rises above 88°C, and it is reset manually.

Resetting

The temperature limiter (FQ11) can be accessed behind the front cover. Reset the temperature limiter by pressing the button (FQ11-SF2) using a small screwdriver.

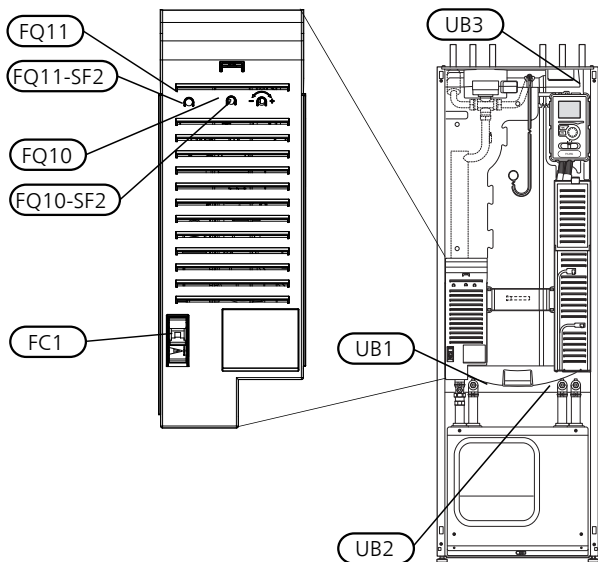

Removing the cover, immersion heater circuit board

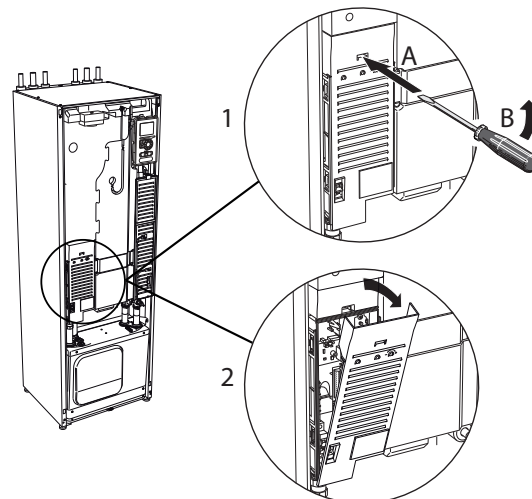

1. Insert the screwdriver (A) and pry the catch carefully downwards (B).
2. Angle out the cover and remove it.

ACCESSIBILITY, ELECTRICAL CONNECTION

The plastic cap of the electrical boxes is opened using a screwdriver.



NOTE

The cover for the input card is opened without a tool.

Removing the cover, base board



Caution

To remove the cover for the base board, the cover for the input circuit board must first be removed.

Removing the cover, input circuit board

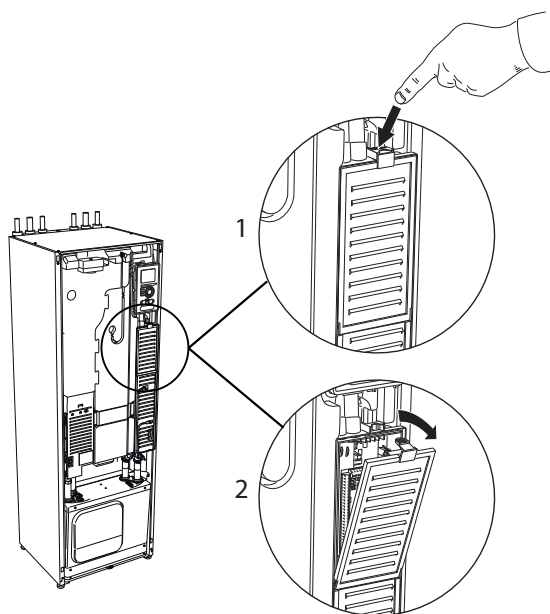

1. Push the catch down.
2. Angle out the cover and remove it.

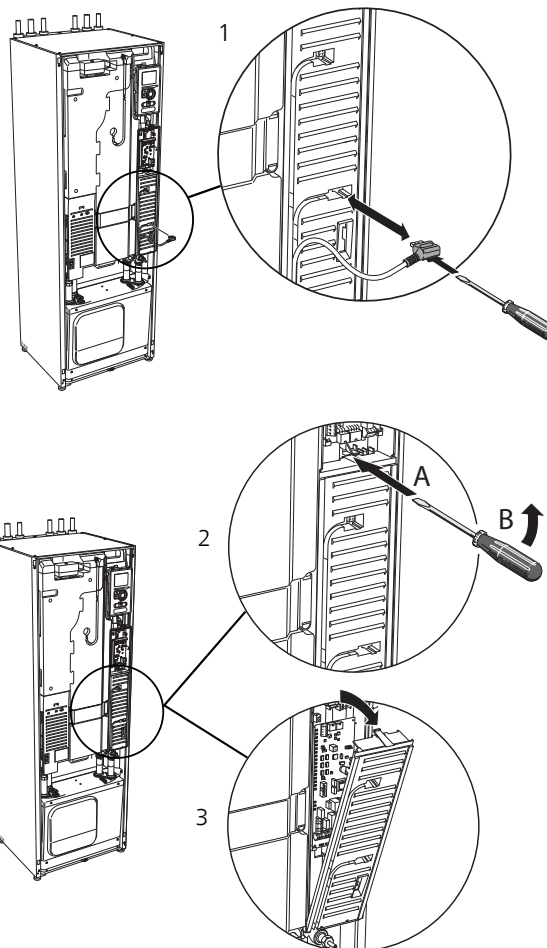

1. Disconnect the switches using a screwdriver.
2. Insert the screwdriver (A) and pry the catch carefully downwards (B).
3. Angle out the cover and remove it.

CABLE LOCK

Use a suitable tool to release/lock cables in the heat pump terminal blocks.

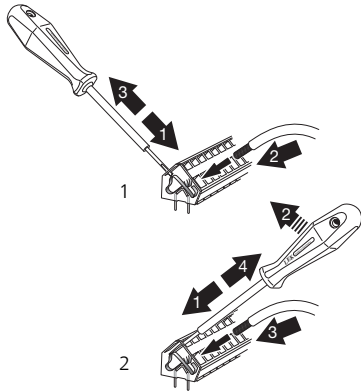

Connections



NOTE

To prevent interference, unshielded communication and/or sensor to external connections cables must not be laid closer than 20 cm to high voltage cable when cable routing.

POWER CONNECTION

F1255 must be installed with a disconnection option on the supply cable. Minimum cable area must be sized according to the fuse rating used. Enclosed cable for incoming supply electricity is connected to terminal block X1 on the immersion heater board (AA1). All installations must be carried out in accordance with current norms and directives.

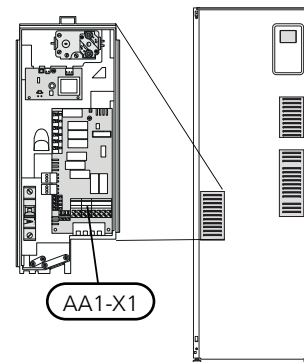

Connection 1x230V

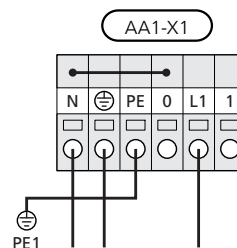

If a separate supply to the compressor and electric heater is wanted, see section "External blocking of functions" on page 30.

TARIFF CONTROL

If the voltage to the immersion heater and/or the compressor disappears during a certain period, there must also be blocking via the AUX-input, see "Connection options - Possible selection for AUX inputs" page. 30

CONNECTING SENSORS

Connect the sensor(s) to terminal X6 on input board(AA3) according to the instructions below.

Outside sensor

Install the outdoor temperature sensor (BT1) in the shade on a wall facing north or north-west, so it is unaffected by the morning sun for example.

Connect the sensor to terminal block X6:1 and X6:2 on the input board (AA3).

If a conduit is used it must be sealed to prevent condensation in the sensor capsule.

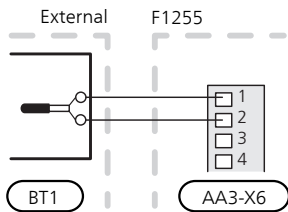
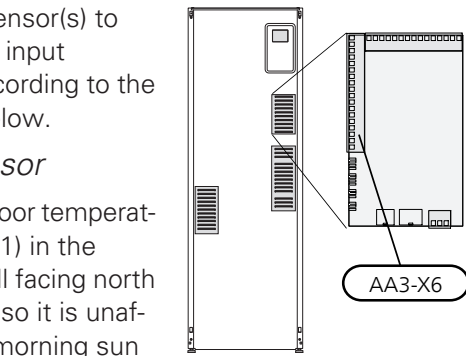

Temperature sensor, external flow line

If temperature sensor, external supply line (BT25) needs to be used, connect it to terminal block X6:5 and X6:6 on the input board (AA3).

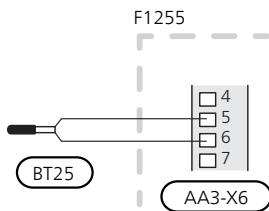

Room sensor

F1255 is supplied with a room sensor enclosed (BT50). The room sensor has a number of functions:

- Shows current room temperature in the display on F1255.
- Option of changing the room temperature in °C.
- Provides the option of fine-tuning the room temperature.

Install the sensor in a neutral position where the set temperature is required. A suitable location is on a free inner wall in a hall approx. 1.5 m above the floor. It is important that the sensor is not obstructed from measuring the correct room temperature by being located, for example, in a recess, between shelves, behind a curtain, above or close to a heat source, in a draft from an external door or in direct sunlight. Closed radiator thermostats can also cause problems.

The heat pump operates without the sensor, but if one wishes to read off the accommodation's indoor temperature in F1255's display, the sensor must be installed. Connect the room sensor to X6:3 and X6:4 on the input board (AA3).

If the sensor is to be used to change the room temperature in °C and/or to fine-tune the room temperature, the sensor must be activated in menu 1.9.4.

If the room sensor is used in a room with underfloor heating, it should only have an indicative function, not control of the room temperature.

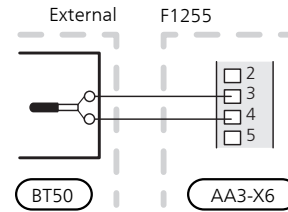

Caution

Changes of temperature in accommodation take time. For example, short time periods in combination with underfloor heating will not give a noticeable difference in room temperature.

Settings

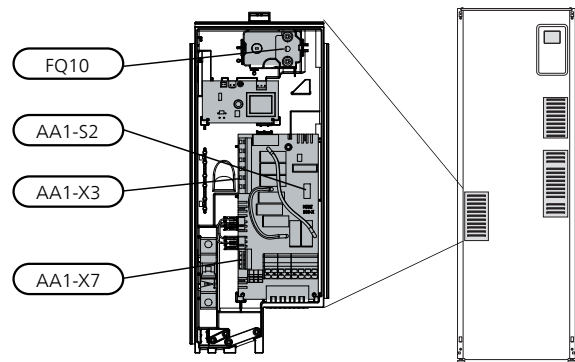

ELECTRICAL ADDITION - MAXIMUM OUTPUT

F1255-12	Max	Number of connection steps
1x230V	7 kW	7

Setting max electrical output

Setting maximum output in the electric additional heat is done in menu 5.1.12.

The table displays the total phase current for the immersion heater at start up. If an immersion heater has already been started and is not used for its full capacity the values in the table can be changed because the control initially uses this immersion heater.

EMERGENCY MODE

When the heat pump is set to emergency mode (SF1 is set to Δ) only the most necessary functions are activated.

- The compressor is off and heating is managed by the immersion heater.
- Hot water is not produced.



NOTE

The switch (SF1) must not be moved to "I" or " Δ " until F1255 has been filled with water. Components in the product can be damaged.

Power in emergency mode

The immersion heater's power in emergency mode is set with the DIP switch (S2) on the immersion heater board (AA1), according to the table below. The factory setting is 6.0 kW for F1255.

Emergency mode thermostat

The supply temperature in emergency mode is set using a thermostat (FQ10). It can be set to 35 (pre-set, for example underfloor heating) or 45 °C (for example radiators).

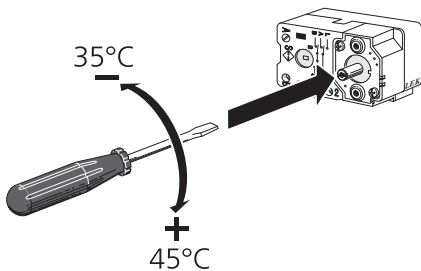

Optional connections

MASTER/SLAVE

Several heat pumps (F1145, F1245 and F1345) can be connected by selecting one heat pump as master and the others as slaves.

The heat pump is always delivered as master and up to till 8 slaves can be connected to it. In systems with several heat pumps each pump must have a unique name, that is only one heat pump can be "Master" and only one can be for example "Slave 5". Set master/slaves in menu 5.2.1.

External temperature sensors and control signals must only be connected to the master, except for external control of the compressor module.



NOTE

When several heat pumps are connected together (master/slave), external return sensor BT71 must be used. If BT71 is not connected, the product gives a sensor fault.

Connect the communications cables as illustrated in series to the terminal block X4:15 (A), X4:14 (B) and X4:13 (GND) on the input card (AA3).

Use cable type LiYY, EKKX or similar.

The example shows the connection of several F1255 .

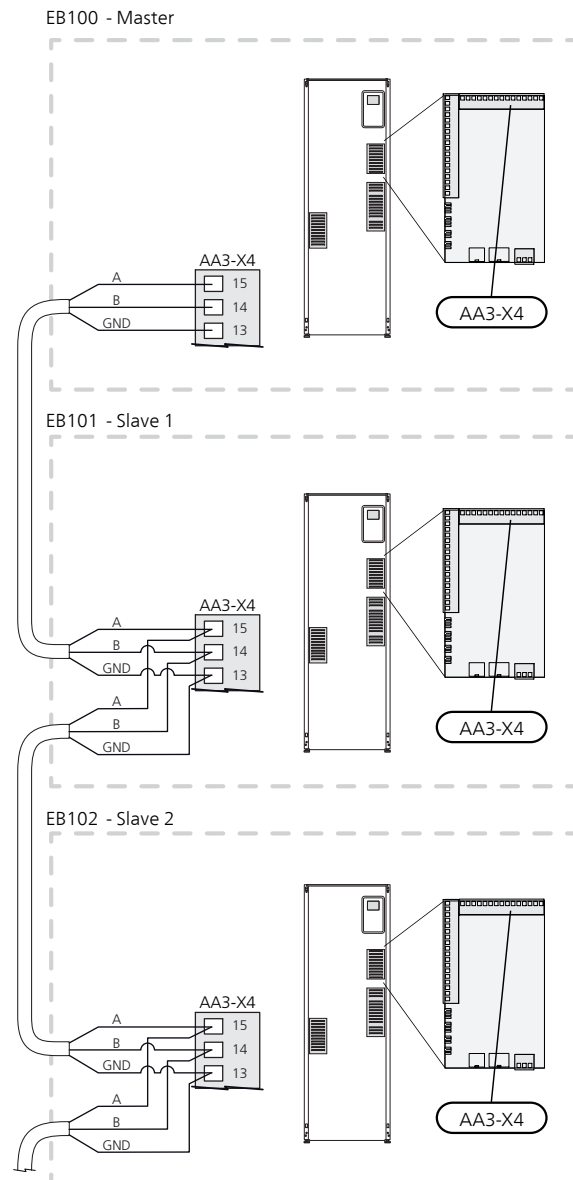

CONNECTING EXTERNAL ENERGY METER



NOTE

Connection of external energy meter requires version 35 or later on input board (AA3) as well as "display version" 7312 or later.

One or two energy meters (BE6, BE7) are connected to terminal block X22 and/or X23 on input board (AA3).

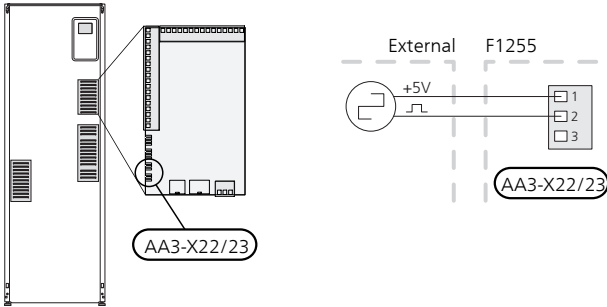

Activate the energy meter(s) in menu 5.2.4 and then set the desired value (energy per pulse) in menu 5.3.21.

NIBE UPLINK

Connect the network connected cable (straight, Cat.5e UTP) with RJ45-contact (male) to RJ45 contact (female) on the rear of the heat pump.

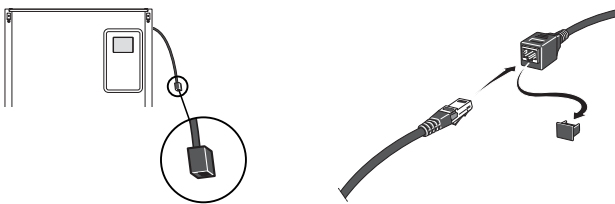

EXTERNAL CONNECTION OPTIONS

F1255 has software-controlled AUX inputs and outputs on the input board (AA3), for connecting the external switch function or sensor. This means that when an external switch function (the switch must be potential-free) or sensor is connected to one of six special connections, this function must be selected for the correct connection in menu 5.4.

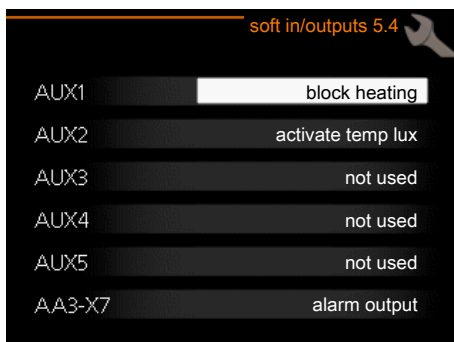

For certain functions, accessories may be required.

Selectable inputs

Selectable inputs on the input board for these functions are:

AUX1	AA3-X6:9-10
AUX2	AA3-X6:11-12
AUX3	AA3-X6:13-14
AUX4	AA3-X6:15-16
AUX5	AA3-X6:17-18

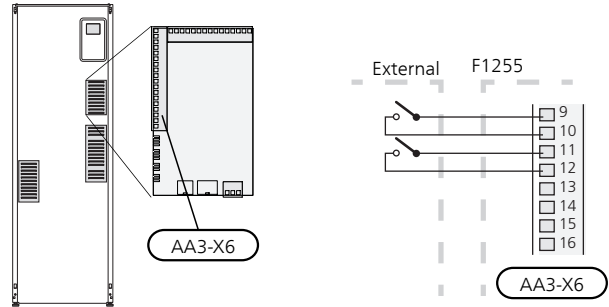

The example above uses the inputs AUX1 (X6:9-10) and AUX2 (X6:11-12) on the input board (AA3).

Selectable output

A selectable output is AA3-X7.



TIP

Some of the following functions can also be activated and scheduled via menu settings.

POSSIBLE SELECTION FOR AUX INPUTS

Temperature sensor

Temperature sensor can be connected to F1255.

Available options are:

- external supply line (BT25) (control of temperature to the heating system)
- cooling/heating (BT74), determines when it is time to switch between cooling and heating mode (can be selected when the cooling function is activated in menu 5.2.4).
- return temperature (BT71)

Monitor

Available options are:

- alarm from external units. The alarm is connected to the control, which means that the malfunction is presented as an information message in the display. Potential-free signal of type NO or NC.
- level (accessory NV10), pressure/flow monitor for the brine (NC).
- pressure switch for climate system (NC).

External activation of functions

An external switch function can be connected to F1255 to activate various functions. The function is activated during the time the switch is closed.

Possible functions that can be activated:

- forced control of brine pump
- hot water comfort mode "temporary lux"
- hot water comfort mode "economy"
- "external adjustment"

When the switch is closed, the temperature changes in °C (if the room sensor is connected and activated). If a room sensor is not connected or not activated, the desired change of "temperature" (heating curve offset) is set with the number of steps selected. The value is adjustable between -10 and +10. External adjustment of climate systems 2 to 8 requires accessories.

– climate system 1 to 8

The value for the change is set in menu 1.9.2, "external adjustment".

- activation of one of four fan speeds.
(Can be selected if ventilation accessory is activated.)
The following five options are available:
 - 1-4 is normally open (NO)
 - 1 is normally closed (NC)

The fan speed is activated during the time the switch is closed. Normal speed is resumed when the switch is opened again.

• +Adjust

Using +Adjust, the installation communicates with the underfloor heating's control centre* and adjusts the heating curve and calculated supply temperature according to the underfloor heating system's reconnection.

Activate the climate system you want +Adjust to affect by highlighting the function and pressing the OK button.

*Support for +Adjust required



Caution

This accessory may require a software update in your F1255. The version can be checked in the "Service info" menu 3.1. Visit nibeuplink.com and click on the "Software" tab to download the latest software to your installation.



Caution

In systems with both underfloor heating and radiators, NIBE ECS 40/41 should be used for optimum operation.

- SG ready



Caution

This function can only be used in mains networks that support the "SG Ready" standard. "SG Ready" requires two AUX inputs.

"SG Ready" is a smart form of tariff control, through which your electricity supplier can affect the indoor, hot water and/or pool temperatures (if applicable) or simply block the additional heat and/or compressor in the heat pump at certain times of the day (can be selected in menu 4.1.5 after the function is activated). Activate the function by connecting potential-free switch functions to two inputs selected in menu 5.4 (SG Ready A and SG Ready B).

Closed or open switch means one of the following:

– Blocking (A: Closed, B: Open)

"SG Ready" is active. The compressor in the heat pump and additional heat is blocked like the day's tariff blocking.

– Normal mode (A: Open, B: Open)

"SG Ready" is not active. No effect on the system.

– Low price mode (A: Open, B: Closed)

"SG Ready" is active. The system focuses on costs savings and can for example exploit a low tariff from the electricity supplier or over-capacity from any own power source (effect on the system can be adjusted in the menu 4.1.5).

– Overcapacity mode (A: Closed, B: Closed)

"SG Ready" is active. The system is permitted to run at full capacity at over capacity (very low price) with the electricity supplier (effect on the system is settable in menu 4.1.5).

(A = SG Ready A and B = SG Ready B)

External blocking of functions

An external switch function can be connected to F1255 for blocking various functions. The switch must be potential-free and a closed switch results in blocking.



NOTE

Blocking entails a risk of freezing.

Functions that can be blocked:

- heating (blocking of heating demand)

- hot water (hot water production). Any hot water circulation (HWC) remains in operation.
- compressor
- internally controlled additional heat
- tariff blocking (additional heat, compressor, heating, cooling and hot water are disconnected)

POSSIBLE SELECTION FOR AUX OUTPUT (POTENTIAL FREE VARIABLE RELAY)

It is possible to have an external connection through the relay function via a potential free variable relay (max 2 A) on the input circuit board (AA3), terminal block X7.

Optional functions for external connection:

- Indication of buzzer alarm.
- Controlling ground water pump.
- Cooling mode indication (only applies if cooling accessories are available).
- Control of circulation pump for hot water circulation.
- External circulation pump (for heating medium).
- External, reversing valve for hot water.
- Holiday indication.

If any of the above is installed to terminal block X7 it must be selected in menu 5.4, see page 55.

The common alarm is preselected at the factory.

NOTE
An accessory card is required if several functions are connected to terminal block X7 at the same time that the buzzer alarm is activated (see page 67).

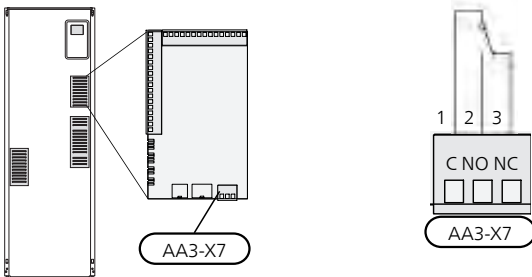

The picture shows the relay in the alarm position.

When switch (SF1) is in the "⏻" or "⚠" position the relay is in the alarm position.

External circulation pump, ground water pump or hot water circulation pump connected to the buzzer alarm relay as illustrated below.

NOTE
Mark up any junction boxes with warnings for external voltage.

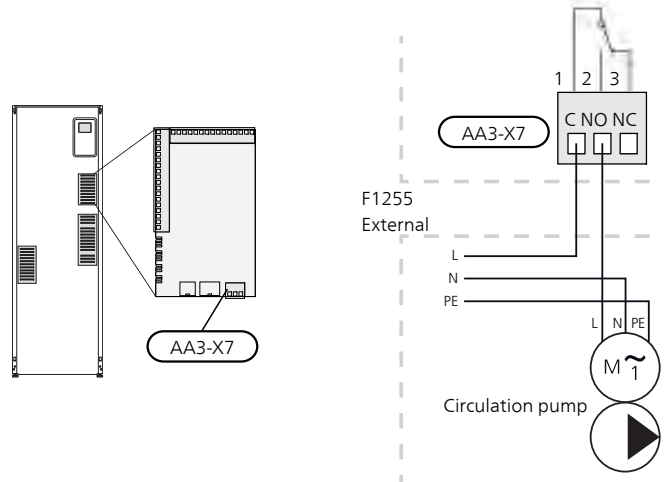

Caution
The relay outputs can have a max load of 2 A (230V ~).

Connecting accessories

Instructions for connecting accessories are in the installation instructions provided for the respective accessory. See information at nibe.co.uk for the list of the accessories that can be used with F1255.

ACCESSORIES WITH CIRCUIT BOARD AA5

Accessories that contain circuit board AA5 are connected to the heat pump terminal block AA3-X4: 13-15. Use cable type LiYY, EKKX or similar.

If several accessories are to be connected, connect the first accessory card directly to the heat pump terminal block. Other accessory boards are connected to the first in series.

Because there can be different connections for accessories with circuit boards AA5, you should always read the instructions in the manual for the accessory that you are going to install.

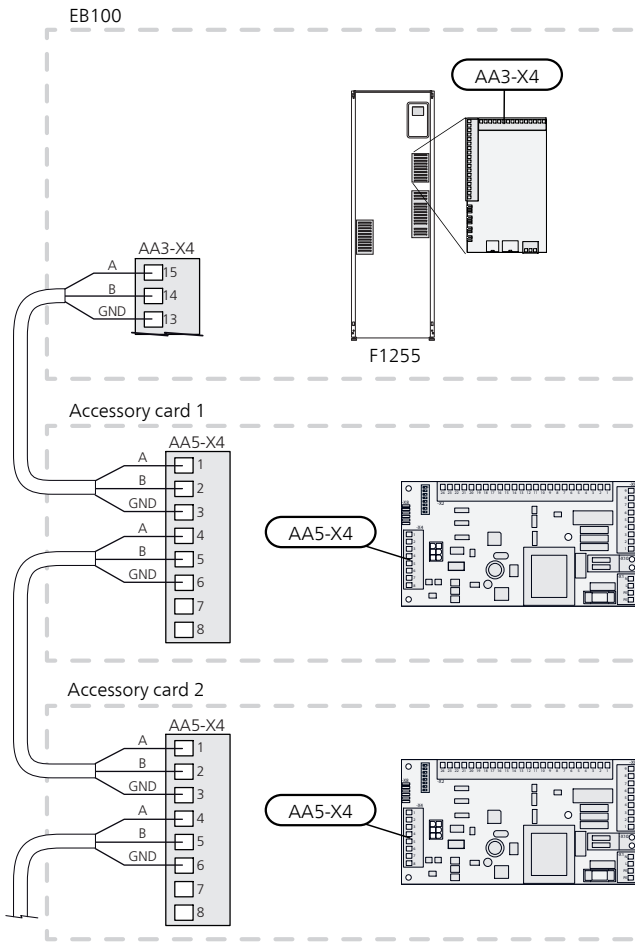

ACCESSORIES WITH CIRCUIT BOARD AA9

Accessories that contain the circuit board AA9 are connected to the heat pump's terminal block X4:9-12 on the input board AA3. Use cable type LiYY, EKKX or equivalent.

Because there can be different connections for accessories with circuit boards AA9, you should always read the instructions in the manual for the accessory that you are going to install.

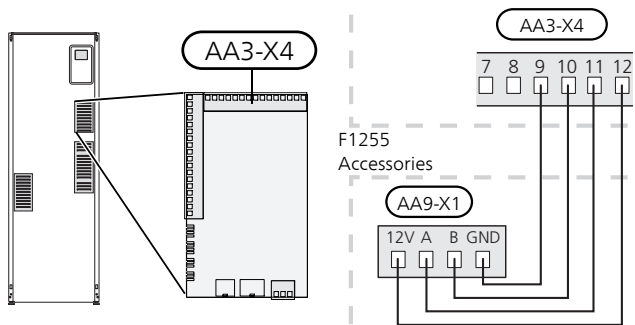

6 Commissioning and adjusting

Preparations

1. Check that the switch (SF1) is in position " ⏻".
2. Check for water in the hot water heater and climate system.



Caution

Check the miniature circuit-breaker and the motor protection breakers. They may have tripped during transportation.



NOTE

Do not start F1255 if there is a risk that the water in the system has frozen.



NOTE

At the time of commissioning, complete all relevant sections of the Benchmark Checklist located at the back of this document.

Completion of the Benchmark Checklist is a condition of warranty. For full terms and conditions of warranty, please see our website nibe.co.uk.

Filling and venting



Caution

Insufficient venting can damage internal components in F1255.

FILLING AND VENTING THE CLIMATE SYSTEM

Filling

1. Install the enclosed filling valves (QM11), (QM13) and the enclosed filling hose (WN1) between the climate system and incoming cold water.
2. Open the filling valves (QM11), (QM13). Fill the coil in the hot water heater and the rest of the climate system with water.

3. Open the vent valve (QM22) on the heat pump.
4. When the water exiting the vent valve (QM22) is no longer mixed with air, close the valve.
5. After a while, the pressure begins to rise on the pressure gauge (BP5). When the pressure reaches 2.5 bar (0.25 MPa), the safety valve (FL2) starts to release water. Close the filling valves (QM11) and (QM13).
6. When the filling procedure is complete, remove the filling hose (WN1).

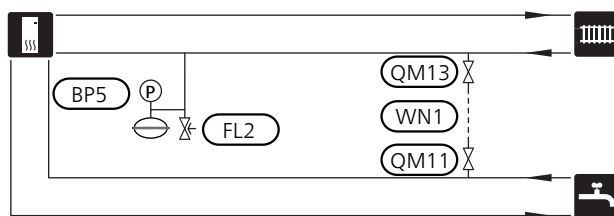

Venting

1. Bleed the heat pump via a vent valve (QM22) and the rest of the climate system via their relevant vent valves.
2. Keep topping up and venting until all air has been removed and the pressure is correct.



NOTE

The pipe from the coil in the container must be drained of water before air can be released. This means that the system is not necessarily bled despite the flow of water when the vent valve (QM22) is opened.

FILLING THE HOT WATER HEATER

1. Open a hot water tap in the house.
2. Fill the hot water heater through the cold water connection (XL3).
3. When the water that comes out of the hot water tap is no longer mixed with air, the water heater is full and the tap can be closed.

FILLING AND VENTING THE BRINE SYSTEM

When filling the brine system, mix the water with anti-freeze in an open container. The mixture should be protected against freezing down to about -15°C. The brine is topped up by connecting a filling pump.

1. Check the brine system for leakage.
2. Connect the filling pump and return line on the brine system's filling connection (accessory).
3. Close the reversing valve in the filling connection.
4. Open the valves on the filler connector.
5. Start the filling pump.
6. Fill until liquid enters the return pipe.
7. Close the valves on the filler connector.
8. Open the reversing valve in the filling connection.

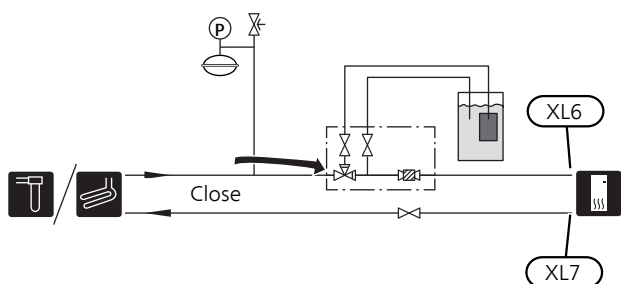

Start-up and inspection

START GUIDE



NOTE

There must be water in the climate system before the switch is set to "I".



NOTE

With several heat pumps connected, the start guide must first be run in the subordinate heat pumps.

In the heat pumps that are not the main unit, you can only make settings for each heat pump's circulation pumps. Other settings are made and controlled by the main unit.

1. Set switch (SF1) on F1255 to position "I".
2. Follow the instructions in the display's start guide. If the start guide does not start when you start the F1255, start it manually in menu 5.7.



TIP

See page 38 for a more in-depth introduction to the heat pump's control system (operation, menus etc.).

If the building is cooled when F1255 starts, the compressor may not be able to meet the entire demand without having to use additional heating.

Commissioning

The first time the installation is started a start guide is started. The start guide instructions state what needs to be carried out at the first start together with a run through of the installation's basic settings.

The start guide ensures that the start-up is carried out correctly and, for this reason, cannot be skipped.



Caution

As long as the start guide is active, no function in the installation will start automatically.

The start guide will appear at each restart of the installation, until it is deselected on the last page.

Operation in the start guide

A. Page

B. Name and menu number

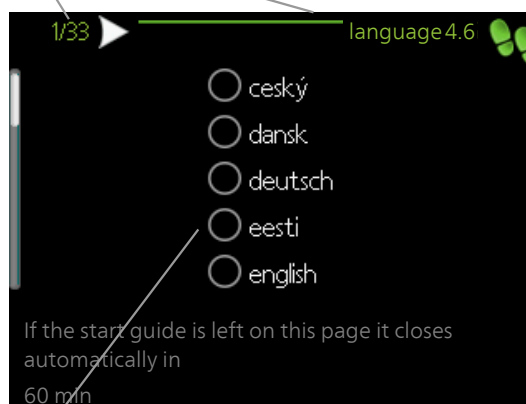

C. Option / setting

A. Page

Here you can see how far you have come in the start guide.

Scroll between the pages of the start guide as follows:

1. Turn the control knob until one of the arrows in the top left corner (at the page number) has been marked.
2. Press the OK button to skip between the pages in the start guide.

B. Name and menu number

Here, you can see which menu in the control system this page of the start guide is based on. The digits in brackets refer to the menu number in the control system.

If you want to read more about affected menus either consult the help menu or read the user manual.

C. Option / setting

Make settings for the system here.

POST ADJUSTMENT AND VENTING

Pump adjustment, automatic operation

Brine side

To set the correct flow in the brine system, the brine pump must run at the correct speed. F1255 has a brine pump that is controlled automatically in standard mode. Certain functions and accessories may demand that it be run manually, in which case the correct speed must be set.



TIP

For optimum operation when several heat pumps are installed in a multi-installation, all heat pumps should have the same compressor size.

This automatic control occurs when the compressor is running and sets the speed of the brine pump so that the optimum temperature difference between the supply and return lines is attained.

Heating medium side

To set the correct flow in the heating medium system, the heating medium pump must run at the correct speed. F1255 has a heating medium pump that can be automatically controlled in standard mode. Certain functions and accessories may require it to run manually and the correct speed must then be set.

This automatic control occurs when the compressor is running and sets the speed of the heating medium pump, for the relevant operating mode, so the optimum temperature difference between the supply and return lines is achieved. During heating operation, the set DOT (dimensioned outdoor temperature) and temperature differential in menu 5.1.14 are used. If necessary, the maximum speed of the circulation pump can be limited in menu 5.1.11.

Pump adjustment, manual operation

Brine side

F1255 has a brine pump that can be automatically controlled. For manual operation: deactivate "auto" in menu 5.1.9 and then set the speed according to the diagram below.



Caution

When an accessory for passive cooling is used, the brine pump speed must be set in menu 5.1.9.

Set the pump speed when the system has come into balance (ideally 5 minutes after compressor start).

Adjust the flow so the temperature difference between brine out (BT11) and brine in (BT10) is between 2 - 5 °C. Check these temperatures in menu 3.1 "service info" and adjust the brine pump's (GP2) speed until the temperature difference is obtained. A large difference indicates a low brine flow and a small difference indicates a high brine flow.

— Available pressure, kPa
— p Electrical output, W

F1255 6 kW

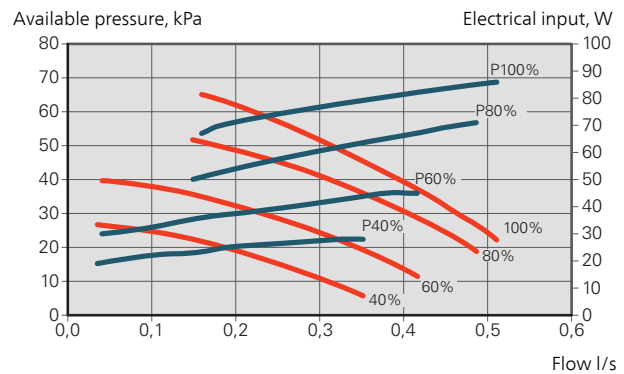

F1255 12 kW

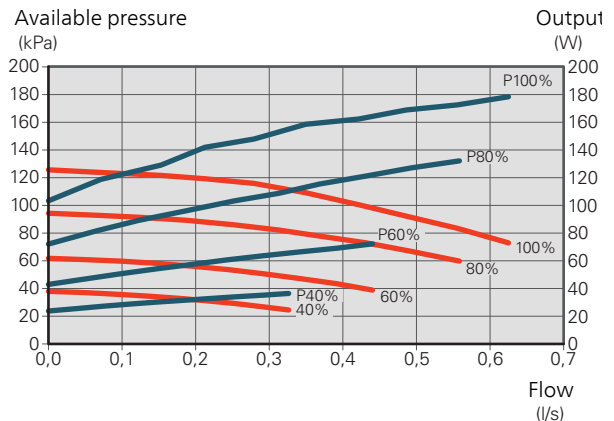

Heating medium side

F1255 has a heating medium pump that can be automatically controlled. For manual operation: deactivate "auto" in menu 5.1.11 and then set the speed according to the diagrams below.

The flow must have a suitable temperature difference for the operating case (heating operation: 5 - 10 °C, hot water generation: 5 - 10 °C, pool heating: approx. 15 °C) between controlling supply temperature sensor and return line sensor. Check these temperatures in menu 3.1 "service info" and adjust the heating medium pump

(GP1) speed until the temperature difference is attained. A high difference indicates a low heating medium supply and a low difference indicates a high heating medium supply.

— Available pressure, kPa
 —_p Electrical output, W

Readjusting, venting, heat medium side

Air is initially released from the hot water and venting may be necessary. If gurgling sounds can be heard from the heat pump or climate system, the entire system requires additional venting. Check the pressure in the pressure expansion vessel (CM1) with the pressure gauge (BP5). If the pressure drops, the system should be replenished.

Readjusting, venting, collector side

Expansion vessel

Check the pressure in the pressure expansion vessel (CM3) with the pressure gauge (BP6). If the pressure drops, the system should be replenished.

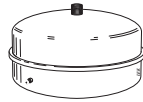

Setting the heating curve

In menu **Curve, heating** you can view the heating curve for your house. The task of the curve is to give an even indoor temperature, regardless of the outdoor temperature, and thereby energy-efficient operation. Based on this curve, the F1255 determines the temperature of the water to the climate system (the supply temperature) and thus the indoor temperature.

CURVE COEFFICIENT

The slope of the heating curve indicates how many degrees the supply temperature is to be increased/reduced when the outdoor temperature drops/increases. A steeper slope means a higher supply temperature at a certain outdoor temperature.

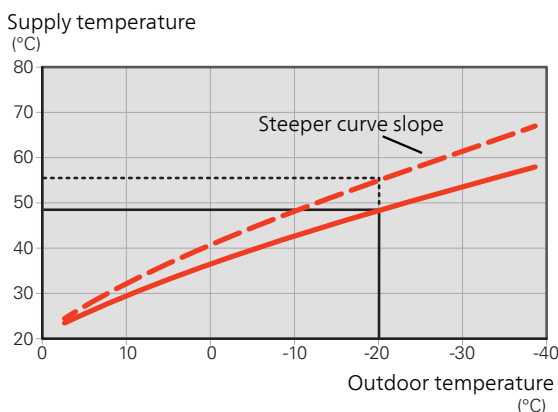

The optimum curve slope depends on the climate conditions in your location, whether the house has radiators, fan coils or underfloor heating and how well insulated the house is.

The heating curve is set when the heating installation is installed, but may need adjusting later. Normally, the curve will not need further adjustment.

CURVE OFFSET

An offset of the heating curve means that the supply temperature is changed by the same amount for all outdoor temperatures, e.g. a curve offset of +2 steps increases the supply temperature by 5 °C at all outdoor temperatures.

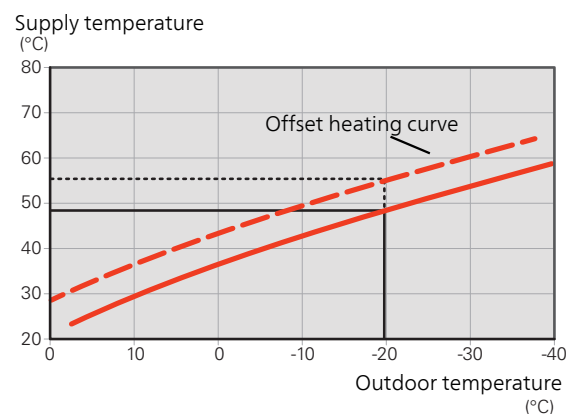

SUPPLY TEMPERATURE – MAXIMUM AND MINIMUM VALUES

Because the flow line temperature cannot be calculated higher than the set maximum value or lower than the set minimum value the heating curve flattens out at these temperatures.

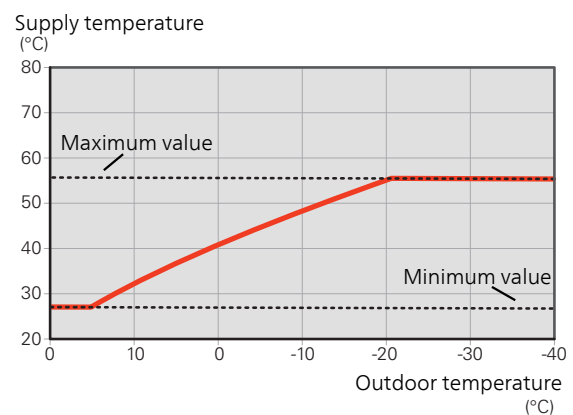

Caution

With underfloor heating systems, the maximum supply temperature is normally set between 35 and 45 °C.

Check the max floor temperature with your floor supplier.

ADJUSTMENT OF CURVE

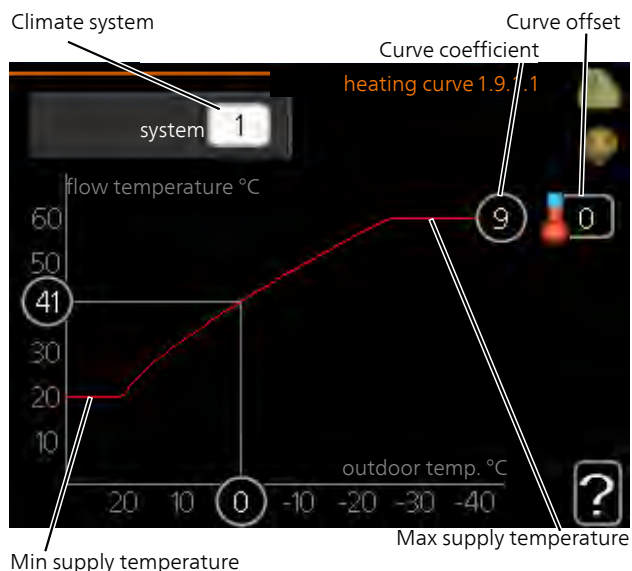

1. Select the climate system (if more than one) for which the curve is to be changed.
2. Select curve slope and curve offset.



Caution

If you need to adjust "min. flow line temp." and/or "max flow line temperature", you do this in other menus.

Settings for "min. flow line temp." in menu 1.9.3.

Settings for "max flow line temperature" in menu 5.1.2.



Caution

Curve 0 means that **own curve** is used.

Settings for **own curve** are made in menu 1.9.7.

TO READ OFF A HEATING CURVE

1. Turn the control knob so that the ring on the shaft with the outdoor temperature is marked.
2. Press the OK button.
3. Follow the grey line up to the curve and out to the left to read off the value for the supply temperature at the selected outdoor temperature.
4. You can now select to take read outs for different outdoor temperatures by turning the control knob to the right or left and read off the corresponding flow temperature.
5. Press the OK or Back button to exit read off mode.

BASIC VALUES FOR THE AUTOMATIC HEATING CONTROL

The values stated on the map apply for the "heating curve" in menu 1.9.1

- The first value applies to low temperature radiator systems¹. "temperature" (offset heating curve) in menu 1.1 must be set to -2.
- The value in brackets refers to underfloor heating systems² installed in concrete floor structures.
- When the system is installed in a timber floor structure you can use the number before the brackets, but this value must be reduced by two units. "temperature" (offset heating curve) in menu 1.1, set in these cases to -1.

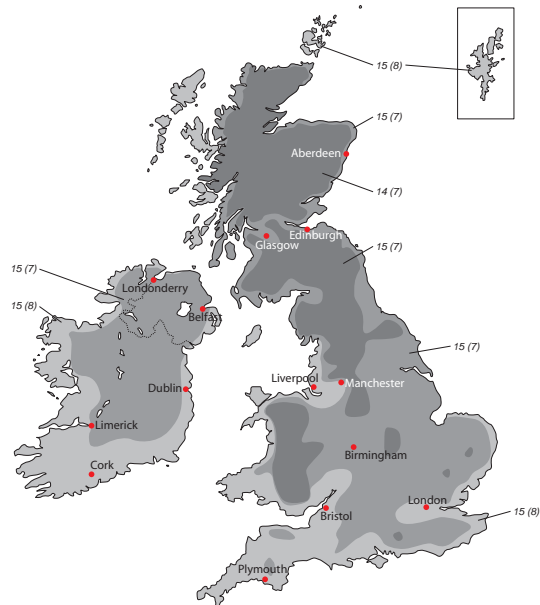

Caution

The map's values are usually a good starting point and are intended to produce a room temperature of approximately 20 °C. The values can be adjusted later if necessary.

Examples of basic values selection:

- House with low temperature radiator system
London = Area 15 (8).
Set 15 in menu 1.9.1, "heating curve" and -2 in menu 1.1 "temperature" (offset of heating curve).
- House with underfloor heating installed in a concrete floor structure
London = Area 15 (8).
Set 8 in menu 1.9.1, "heating curve" and -2 in menu 1.1 "temperature" (offset of heating curve).
- House with underfloor heating installed in a timber floor structure
London = Area 15 (8).
Set 13 (see point three in the list above) in menu 1.9.1, "heating curve" and -1 in menu 1.1 "temperature" (offset of heating curve).



Caution

An increase in the room temperature can be slowed by the thermostats for the radiators or under floor heating. Therefore, open the thermostat valves fully, except in those rooms where a cooler temperature is required, e.g. bedrooms.

¹ A low-temperature radiator system refers to a system where the supply temperature needs to be 55 °C on the coldest day.

² Under floor heating can be dimensioned very differently. The above example refers to a system where the supply temperature needs to be approximately 35 – 40 °C or 45 – 50 °C on the coldest day.

7 Control - Introduction

Display unit

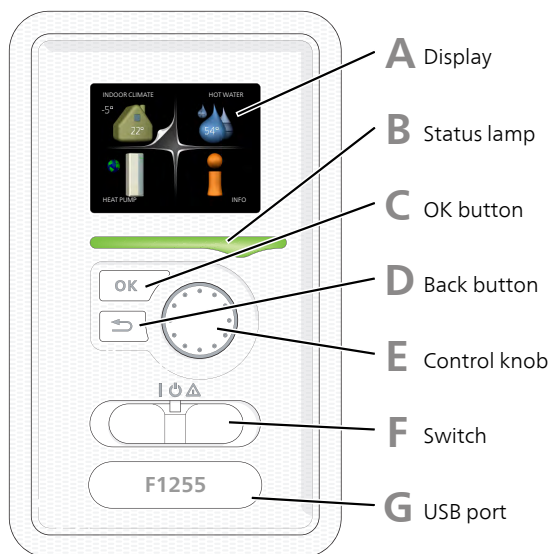

A DISPLAY

Instructions, settings and operational information are shown on the display. You can easily navigate between the different menus and options to set the comfort or obtain the information you require.

B STATUS LAMP

The status lamp indicates the status of the heat pump. It:

- lights green during normal operation.
- lights yellow in emergency mode.
- lights red in the event of a deployed alarm.

C OK BUTTON

The OK button is used to:

- confirm selections of sub menus/options/set values/page in the start guide.

D BACK BUTTON

The back button is used to:

- go back to the previous menu.
- change a setting that has not been confirmed.

E CONTROL KNOB

The control knob can be turned to the right or left. You can:

- scroll in menus and between options.
- increase and decrease the values.
- change page in multiple page instructions (for example help text and service info).

F SWITCH (SF1)

The switch assumes three positions:

- On (I)
- Standby (⏻)
- Emergency mode (⚠)

Emergency mode must only be used in the event of a fault on the heat pump. In this mode, the compressor switches off and the immersion heater engages. The heat pump display is not illuminated and the status lamp illuminates yellow.

G USB PORT

The USB port is hidden beneath the plastic badge with the product name on it.

The USB port is used to update the software.

Visit nibeuplink.com and click the "Software" tab to download the latest software for your installation.

Menu system

When the door to the heat pump is opened, the menu system's four main menus are shown in the display as well as certain basic information.

MASTER

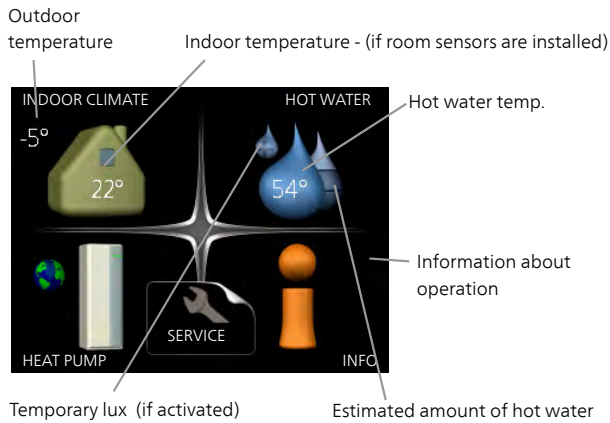

MENU 4 - HEAT PUMP

Setting time, date, language, display, operating mode etc. See information in the help menu or user manual.

MENU 5 - SERVICE

Advanced settings. These settings are only intended for installers or service engineers. The menu is visible when the Back button is pressed for 7 seconds, when you are in the start menu. See page 45.

This menu is also set in the slave heat pump's limited menu system.

SLAVE

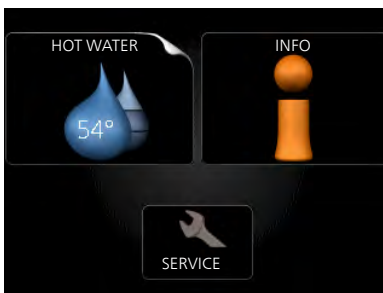

If the heat pump is set as slave a limited main menu is displayed because the majority of the settings for the system are made at the master heat pump.

MENU 1 - INDOOR CLIMATE

Setting and scheduling the indoor climate. See information in the help menu or user manual.

MENU 2 - HOT WATER

Setting and scheduling hot water production. See information in the help menu or user manual.

This menu is also set in the slave heat pump's limited menu system.











MENU 3 - INFO

Display of temperature and other operating information and access to the alarm log. See information in the help menu or user manual.

This menu is also set in the slave heat pump's limited menu system.

SYMBOLS IN THE DISPLAY

The following symbols can appear in the display during operation.

<i>Symbol</i>	<i>Description</i>
	This symbol appears by the information sign if there is information in menu 3.1 that you should note.
	<p>These two symbols indicate whether the compressor or addition is blocked in F1255.</p> <p>These can, for example, be blocked depending on which operating mode is selected in menu 4.2, if blocking is scheduled in menu 4.9.5 or if an alarm has occurred that blocks one of them.</p>
	Blocking the compressor.
	Blocking additional heat.
	This symbol appears if periodic increase or lux mode for the hot water is activated.
	This symbol indicates whether "holiday setting" is active in 4.7.
	This symbol indicates whether F1255 has contact with NIBE Uplink.
	<p>This symbol indicates the actual speed of the fan if the speed has changed from the normal setting.</p> <p>Accessory needed.</p>
	<p>This symbol indicates whether pool heating is active.</p> <p>Accessory needed.</p>
	<p>This symbol indicates whether cooling is active.</p> <p>Accessory needed.</p>

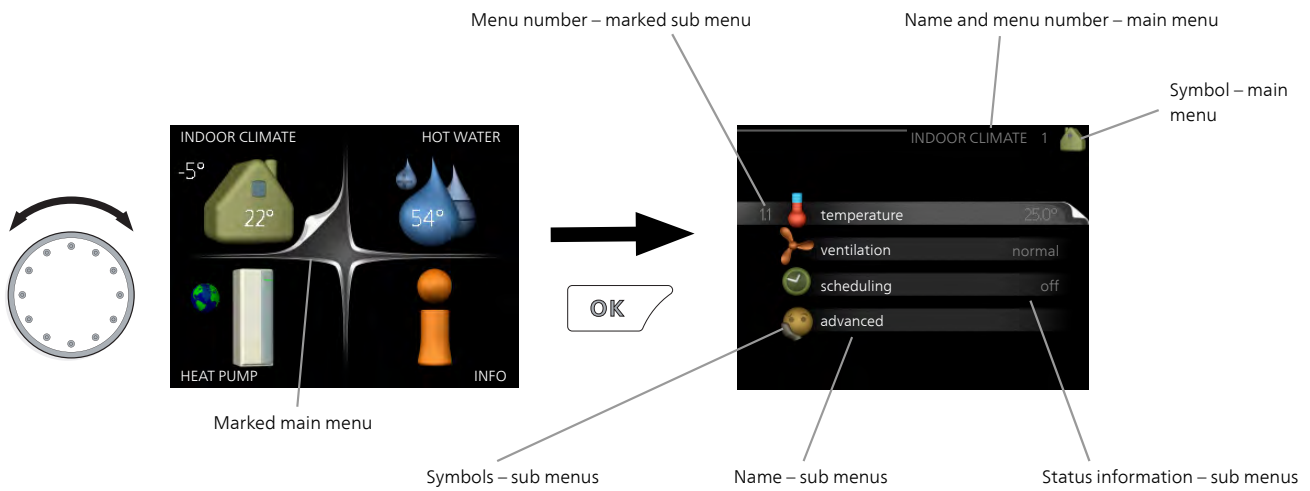

OPERATION

To move the cursor, turn the control knob to the left or the right. The marked position is white and/or has a turned up tab.

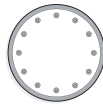

SELECTING MENU

To advance in the menu system select a main menu by marking it and then pressing the OK button. A new window then opens with sub menus.

Select one of the sub menus by marking it and then pressing the OK button.



SELECTING OPTIONS



In an options menu the current selected option is indicated by a green tick.



To select another option:





1. Mark the applicable option. One of the options is pre-selected (white). 
2. Press the OK button to confirm the selected option. The selected option has a green tick. 

SETTING A VALUE



Values to be changed

To set a value:

1. Mark the value you want to set using the control knob. 
2. Press the OK button. The background of the value becomes green, which means that you have accessed the setting mode. 
3. Turn the control knob to the right to increase the value and to the left to reduce the value. 
4. Press the OK button to confirm the value you have set. To change and return to the original value, press the Back button. 

USE THE VIRTUAL KEYBOARD

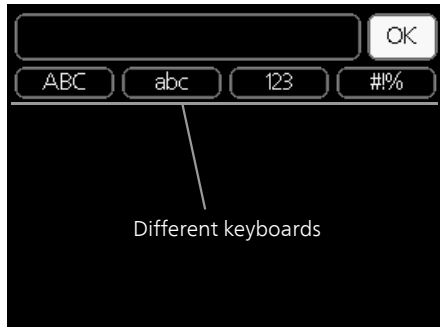

In some menus where text may require entering, a virtual keyboard is available.



Depending on the menu, you can gain access to different character sets which you can select using the control knob. To change character table, press the Back button. If a menu only has one character set the keyboard is displayed directly.

When you have finished writing, mark "OK" and press the OK button.

SCROLL THROUGH THE WINDOWS

A menu can consist of several windows. Turn the control knob to scroll between the windows.



Current menu window Number of windows in the menu

Scroll through the windows in the start guide



Arrows to scroll through window in start guide

1. Turn the control knob until one of the arrows in the top left corner (at the page number) has been marked.
2. Press the OK button to skip between the steps in the start guide.

HELP MENU

 In many menus there is a symbol that indicates that extra help is available.

To access the help text:

1. Use the control knob to select the help symbol.
2. Press the OK button.

The help text often consists of several windows that you can scroll between using the control knob.

8 Control - Menus

Menu 1 - INDOOR CLIMATE

1 - INDOOR CLIMATE	1.1 - temperature	1.1.1 - heating			
			1.1.2 - cooling *		
	1.2 - ventilation *				
	1.3 - scheduling	1.3.1 - heating			
		1.3.2 - cooling *			
		1.3.3 - ventilation *			
	1.9 - advanced	1.9.1 - curve	1.9.1.1 heating curve		
				1.9.1.2 - cooling curve *	
		1.9.2 - external adjustment			
		1.9.3 - min. flow line temp.	1.9.3.1 - heating		
			1.9.3.2 - cooling *		
		1.9.4 - room sensor settings			
		1.9.5 - cooling settings *			
1.9.6 - fan return time *					
1.9.7 - own curve		1.9.7.1 - heating			
		1.9.7.2 - cooling *			
1.9.8 - point offset					
1.9.9 - night cooling					
1.9.11 - +Adjust					
1.9.12 - FLM cooling*					

Menu 2 - HOT WATER

2 - HOT WATER, **	2.1 - temporary lux			
	2.2 - comfort mode			
	2.3 - scheduling			
	2.9 - advanced	2.9.1 - periodic increase		
		2.9.2 - hot water recirc.		

Menu 3 - INFO

3 - INFO **	3.1 - service info **
	3.2 - compressor info **
	3.3 - add. heat info **
	3.4 - alarm log **
	3.5 - indoor temp. log

* Accessories are needed.

** This menu is also set in the slave heat pump's limited menu system.

Menu 4 - HEAT PUMP

4 - HEAT PUMP	4.1 - plus functions	4.1.1 - pool *	
		4.1.3 - internet	4.1.3.1 - NIBE Uplink
			4.1.3.8 - tcp/ip settings
			4.1.3.9 - proxy settings
		4.1.4 - sms *	
		4.1.5 - SG Ready	
		4.1.7 - smart home	
		4.1.8 - smart energy source™	4.1.8.1 - settings
			4.1.8.2 - set. price
			4.1.8.3 - CO2 impact
			4.1.8.4 - tariff periods, electricity
			4.1.8.5 - tariff periods, fixed price
			4.1.8.6 - tariff per, ext. shunt add
			4.1.8.7 - tariff per, ext. step add
			4.1.8.8 - tariff periods, OPT10
			Menu 4.1.10 – solar electricity *
		4.2 - op. mode	
		4.3 - my icons	
		4.4 - time & date	
		4.6 - language	
		4.7 - holiday setting	
		4.9 - advanced	4.9.1 - op. prioritisation
			4.9.2 - auto mode setting
	4.9.3 - degree minute setting		
	4.9.4 - factory setting user		
	4.9.5 - schedule blocking		

* Accessory needed.

Menu 5 - SERVICE

OVERVIEW

5 - SERVICE **	5.1 - operating settings **	5.1.1 - hot water settings
		5.1.2 - max flow line temperature
		5.1.3 - max diff flow line temp.
		5.1.4 - alarm actions
		5.1.5 - fan sp. exhaust air *
		5.1.7 - br pmp al set.
		5.1.8 - operating mode brine pump **
		5.1.9 - brine pump speed **
		5.1.10 - op. mod heat med pump **
		5.1.11 - pump speed heating medium **
		5.1.12 - internal electrical addition
		5.1.14 - flow set. climate system
		5.1.22 - heat pump testing
		5.1.24 - blockFreq
	5.2 - system settings	5.2.1 - master/slave mode **
		5.2.2 - installed slaves
		5.2.3 - docking
		5.2.4 - accessories
	5.3 - accessory settings	5.3.1 - FLM *
		5.3.2 - shunt controlled add. heat *
		5.3.4 - solar heating *
		5.3.6 - step controlled add. heat
		5.3.8 - hot water comfort *
		5.3.11 - modbus *
		5.3.12 - exhaust/supply air module *
		5.3.15 - GBM communications module *
		5.3.16 - humidity sensor *
		5.3.21 - flow sensor / energy meter*
	5.4 - soft in/outputs **	
	5.5 - factory setting service **	
	5.6 - forced control **	
	5.7 - start guide **	
	5.8 - quick start **	
	5.9 - floor drying function	
	5.10 - change log **	

* Accessory needed.

** This menu is also set in the slave heat pump's limited menu system.

Go to the main menu and hold the Back button in for 7 seconds to access the Service menu.

Sub-menus

Menu **SERVICE** has orange text and is intended for the advanced user. This menu has several sub-menus. Status information for the relevant menu can be found on the display to the right of the menus.

operating settings Operating settings for the heat pump.

system settings System settings for the heat pump, activating accessories etc.

accessory settings Operational settings for different accessories.

soft in/outputs Setting software controlled in and outputs on the input circuit board (AA3).

factory setting service Total reset of all settings (including settings available to the user) to default values.

forced control Forced control of the different components in the heat pump.

start guide Manual start of the start guide which is run the first time the heat pump is started.

quick start Quick starting the compressor.



NOTE

Incorrect settings in the service menus can damage the heat pump.

MENU 5.1 - OPERATING SETTINGS

Operating settings can be made for the heat pump in the sub menus.

MENU 5.1.1 - HOT WATER SETTINGS

start temp. economy / normal / lux

Setting range: 5 – 70 °C

Factory setting (°C):

	<i>eco- nomy</i>	<i>normal</i>	<i>luxury</i>
Enamel	40	44	47
Copper	40	44	47
Stainless	40	44	47

stop temp. economy / normal / lux

Setting range: 5 – 70 °C

Factory setting (°C):

	<i>eco- nomy</i>	<i>normal</i>	<i>luxury</i>
Enamel	44	48	51
Copper	44	48	51
Stainless	44	48	51

stop temp. per. increase

Setting range: 55 – 70 °C

Factory setting: 55 °C

high power

Setting range: on/off

Factory setting: off

Here you set the start and stop temperature of the hot water for the different comfort options in menu 2.2 as well as the stop temperature for periodic increase in menu 2.9.1.

If several compressors are available set the difference between engagement disengagement of them during hot water charging and fixed condensing.

For a higher charge output click the high output selection.

With "high power" activated, the hot water is charged with greater power than standard mode and therefore has a faster recharging time.

MENU 5.1.2 - MAX FLOW LINE TEMPERATURE

climate system

Setting range: 20-80 °C

Default value: 60 °C

Set the maximum supply temperature for the climate system here. If the installation has more than one climate system, individual maximum supply temperatures can be set for each system. Climate systems 2 - 8 cannot be set to a higher max supply temperature than climate system 1.



Caution

For underfloor heating systems, max flow line temperature should normally be set to between 35 and 45°C.

Check the max floor temperature with your floor supplier.

MENU 5.1.3 - MAX DIFF FLOW LINE TEMP.

max diff compressor

Setting range: 1 – 25 °C

Default value: 10 °C

max diff addition

Setting range: 1 – 24 °C

Default value: 3 °C

Here you set the maximum permitted difference between the calculated and actual supply temperature in the event of compressor or additional heat mode respectively. Max diff. additional heat can never exceed max diff. compressor

max diff compressor

If the current supply temperature *exceeds* the calculated supply by set value, the degree minute value is set to +2. The compressor in the heat pump stops if there is only a heating demand.

max diff addition

If "addition" is selected and activated in menu 4.2 and the current supply temperature *exceeds* the calculated temperature by the set value, the additional heat is forced to stop.

MENU 5.1.4 - ALARM ACTIONS

Select how you want the heat pump to alert you that there is an alarm in the display here.

The different alternatives are that the heat pump stops producing hot water (default setting) and/or reduces the room temperature.



Caution

If no alarm action is selected, it can result in higher energy consumption in the event of an alarm.

MENU 5.1.5 - FAN SP. EXHAUST AIR (ACCESSORY IS REQUIRED)

normal and speed 1-4

Setting range: 0 – 100 %

Set the speed for the five different selectable speeds for the fan here.



Caution

An incorrectly set ventilation flow can damage the house and may also increase energy consumption.

MENU 5.1.7 - BR PMP AL SET.

min. brine out

Setting range: -12 – 15 °C

Default value: -8 °C

min. brine out

Set the temperature at which the heat pump is to activate the alarm for low temperature in outgoing brine.

If "automatic reset" is selected, the alarm resets when the temperature has increased by 1 °C below the set value.

The compressor winds down when the brine temperature reaches the set minimum value for brine temperature. Compressor control attempts to maintain the brine at a temperature 2 ° greater than the set value for brine out.

MENU 5.1.8 - OPERATING MODE BRINE PUMP

op. mode

Setting range: intermittent, continuous, 10 days continuous

Default value: intermittent

Set the operating mode of the brine pump here.

intermittent: The brine pump starts approx. 20 seconds before and stops approx. 20 seconds after the compressor.

continuous: Continuous operation.

10 days continuous: Continuous operation for 10 days. The pump then shifts to intermittent operation.



TIP

You can use "10 days continuous" at start-up to obtain continuous circulation during a start-up time in order to make it easier to bleed the system.

MENU 5.1.9 - BRINE PUMP SPEED

op. mode

Setting range: auto / manual / fixed delta

Default value: auto

delta T

Setting range: 2 - 10 °C

Factory setting: 4 °C

speed in wait mode

Setting range: 1 - 100 %

Factory setting: 70 %

Speed extern. contr. (AUX)

Setting range: 1 - 100 %

Factory setting: 100 %

manual

Setting range: 1 - 100 %

Factory setting: 100 %

speed passive cooling (accessory is required)

Setting range: 1 - 100 %

Factory setting: 75 %

speed active cooling (accessory is required)

Setting range: 1 - 100 %

Factory setting: 75 %

speed in wait mode cooling

Setting range: 1 - 100 %

Factory setting: 30 %

temperature difference, active cooling

Setting range: 2 - 10 °C

Factory setting: 5 °C

Set the speed of the brine pump here. Select "auto" if the speed of the brine pump is to be regulated automatically (factory setting) for optimal operation.

For manual operation of the brine pump, deactivate "auto" and set the value to between 1 and 100 %.

For operation of brine pump with "fixed delta", select "fixed delta" under "op. mode" and set the value between 2 and 10 °C.

If there are accessories for cooling, you can also set the brine pump's speed during passive cooling operation here (the brine pump then runs in manual operation).

If the continuous operating mode (see "Menu 5.1.8 - operating mode brine pump", page 47) has been selected one can also choose waiting mode. The circulation pump continues to run while the compressor stops.

This menu is also set in the slave heat pump's limited menu system.

MENU 5.1.10 - OP. MOD HEAT MED PUMP

<p><i>op. mode</i></p> <p>Setting range: auto, intermittent</p> <p>Default value: auto</p>
--

Set the operating mode of the heating medium pump here.

auto: The heating medium pump runs according to the current operating mode for F1255.

intermittent: The heating medium pump starts approx. 20 seconds before, and stops at the same time as, the compressor.

MENU 5.1.11 - PUMP SPEED HEATING MEDIUM

<p><i>Operating status</i></p> <p>Setting range: auto / manual</p> <p>Default value: auto</p>
<p><i>Manual setting, hot water</i></p> <p>Setting range: 1 - 100 %</p> <p>Factory setting: 70 %</p>
<p><i>Manual setting, heating</i></p> <p>Setting range: 1 - 100 %</p> <p>Default values: 70 %</p>
<p><i>Manual setting, pool</i></p> <p>Setting range: 1 - 100 %</p> <p>Default values: 70 %</p>

<p><i>speed in wait mode</i></p> <p>Setting range: 1 - 100 %</p> <p>Default values: 30 %</p>
<p><i>min. allowed speed</i></p> <p>Setting range: 1 - 50%</p> <p>Default values: 1 %</p> <p><i>max. allowed speed</i></p> <p>Setting range: 50 - 100 %</p> <p>Default values: 100 %</p>
<p><i>speed active cooling (accessory is required)</i></p> <p>Setting range: 1 - 100 %</p> <p>Default values: 70 %</p> <p><i>speed passive cooling (accessory is required)</i></p> <p>Setting range: 1 - 100 %</p> <p>Default values: 70 %</p>

Set the speed at which the heating medium pump is to operate in the present operating mode. Select "auto" if the speed of the heating medium pump is to be regulated automatically (factory setting) for optimal operation.

If "auto" is activated for heating operation you can also make the setting "max. allowed speed" which restricts the heating medium pump and does not allow it to run at a higher speed than the set value.

For manual operation of the heating medium pump, deactivate "auto" for the current operating mode and set the value to between 0 and 100% (the previously set value for "max. allowed speed" no longer applies).

"*heating*" means heating operating mode for the heating medium pump.

"*speed in wait mode*" means heating or cooling operating mode for the heating medium pump, but when the heat pump requires neither compressor operation nor electric additional heat and slows down.

"*hot water*" means hot water operating mode for the heating medium pump.

"*pool*" (accessory required) means pool heating operating mode for the heating medium pump.

"*cooling*" (accessory required) means operating mode cooling for the heating medium pump.

If there are accessories for cooling present or if the heat pump has a built-in function for cooling you can also set the heating medium pump speed during active respectively cooling operating modes (the heating medium pump then runs in manual operation).

MENU 5.1.12 - INTERNAL ELECTRICAL ADDITION

fuse size

Setting range: 1 - 400 A

Default values: 25 A

transformation ratio

Setting range: 300 - 3000

Factory setting: 300

Here you set the max. electrical output of the internal electrical addition in F1255 and the fuse size for the installation.

MENU 5.1.14 - FLOW SET. CLIMATE SYSTEM

presettings

Setting range: radiator, floor heat., rad. + floor heat., DOT °C

Default value: radiator

Setting range DOT: -40.0 – 20.0 °C

Factory setting DOT: -18.0 °C

own setting

Setting range dT at DOT: 0.0 – 25.0

Factory setting dT at DOT: 10.0

Setting range DOT: -40.0 – 20.0 °C

Factory setting DOT: -18.0 °C

The type of heating distribution system the heating medium pump (GP1) works towards is set here.

dT at DOT is the difference in degrees between flow and return temperatures at dimensioned outdoor temperature.

MENU 5.1.22 - HEAT PUMP TESTING

NOTE

This menu is intended for testing F1255 according to different standards.

Use of this menu for other reasons may result in your installation not functioning as intended.

This menu contains several sub-menus, one for each standard.

MENU 5.1.24 - BLOCKFREQ

blockFreq 1

Selectable setting range in the display:

start: 17 – 115 Hz

stop: 22 – 120 Hz

Maximum setting range: 50 Hz.

blockFreq 2

Selectable setting range in the display:

start: 17 – 115 Hz

stop: 22 – 120 Hz

Maximum setting range: 50 Hz.

Here you can set a frequency range where the compressor is blocked. The parameters for the setting range differ depending on which product is controlled by the setting.



NOTE

A large blocked frequency range can cause the compressor to run jerkily.

MENU 5.2 - SYSTEM SETTINGS

Make different system settings for the heat pump here, e.g. which accessories are installed.

There are two ways of activating connected accessories. You can either highlight the alternative in the list or use the automatic function "search installed acc."

search installed acc.

Mark "search installed acc." and press the OK button to automatically find connected accessories for F1255.



Caution

Certain accessories are not found automatically but must be ticked off by hand, see menu 5.4.



NOTE

Only mark the option for ground water pump if the accessory AXC 40 is to be used to control the circulation pump.

Make different system settings for the heat pump here, e.g. master/slave settings, docking settings and which accessories are installed.

MENU 5.2.1 - MASTER/SLAVE MODE

Setting range: master, slave 1-8

Default value: master

Set the heat pump as master- or slave unit. In systems with one heat pump it must be "master".



Caution

In systems with several heat pumps, each pump is allocated a unique ID. In other words, only one heat pump can be "master" and only one can be "slave 5".

MENU 5.2.2 - INSTALLED SLAVES

Set which slaves are connected to the master heat pump.

There are two ways of activating connected slaves. You can either mark the alternative in the list or use the automatic function "search installed slaves".



NOTE

Before these settings are made, each slave must have received a unique ID (see menu 5.2.1).

MENU 5.2.3 - DOCKING

Enter how your system is docked regarding pipes, for example to pool heating, hot water heating and heating the building.

This menu has a docking memory which means that the control system remembers how a particular reversing valve is docked and automatically enters the correct docking the next time you use the same reversing valve.

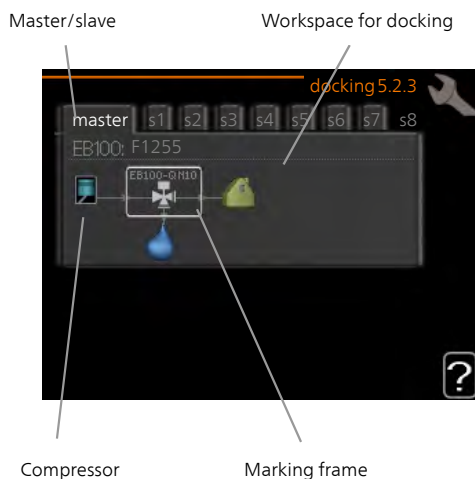

Master/slave: Select the heat pump for which the docking setting is to be made (if there is only one heat pump in the system, only master is displayed).

Compressor: Here, you select whether the compressor is blocked, externally controlled via soft input or standard (docked for example to pool heating, hot water charging and heating the building).

Marking frame: Move around the marking frame using the control knob. Use the OK button to select what you want to change and to confirm the setting in the options box that appears to the right.

Workspace for docking: The system docking is drawn here.

Symbol	Description
	Compressor (blocked)
	Compressor (externally controlled)
	Compressor (standard)
	Reversing valves for hot water, cooling respectively pool control. The designations above the reversing valve indicate where it is electrically connected (EB100 = Master, EB101 = Slave 1, CL11 = Pool 1 etc.).
	Own hot water charging, only from selected heat pump compressor. Controlled by relevant heat pump.
	Pool 1
	Heating (heating the building, includes any extra climate system)
	Cooling

MENU 5.2.4 - ACCESSORIES

Inform the heat pump which accessories are installed here.

There are two ways of activating connected accessories. You can either mark the alternative in the list or use the automatic function "search installed acc.".

search installed acc.

Mark "search installed acc." and press the OK button to automatically find connected accessories for F1255.



Caution

Certain accessories are not found with the search function, but must be selected instead in menu 5.4.



NOTE

Only mark the option for ground water pump if the accessory AXC 40 is to be used to control the circulation pump.

MENU 5.3 - ACCESSORY SETTINGS

The operating settings for accessories that are installed and activated are made in the sub-menus for this.

MENU 5.3.1 - FLM

continuous pump op.

Setting range: on/off

Factory setting: off

pump speed

Setting range: 1 – 100%

Factory setting: 100%

time between defrosts

Setting range: 1 – 30 h

Default value: 10 h

months btwn filter alarms

Setting range: 1 – 12

Default value: 3

activate cooling

Setting range: on/off

Factory setting: off

continuous pump op.: Select for continuous operation of the circulation pump in the exhaust air module.

pump speed: Set the desired speed for the circulation pump in the exhaust air module.

time between defrosts: Here, you can set the minimum time that must pass between defrosts of the heat exchanger in the exhaust air module.

When the exhaust air module is in operation the heat exchanger is cooled so that ice builds up on it. When too much ice builds up the heat transfer capacity of the heat exchanger is reduced and defrosting is required. Defrosting warms up the heat exchanger so that the ice melts and runs off via the condensation hose.

months btwn filter alarms: Here, you can set how many months should pass before the heat pump notifies that it is time to clean the filter in the exhaust air module.

Clean the exhaust air module's air filter regularly, how often depends on the amount of dust in the ventilation air.

activate cooling: Here, you can activate cooling via the exhaust air module. When the function has been activated, the cooling settings are displayed in the menu system.



TIP

See the accessory installation instructions for function description.

MENU 5.3.2 - SHUNT CONTROLLED ADD. HEAT

prioritised additional heat

Setting range: on/off

Factory setting: off

start diff additional heat

Setting range: 0 – 2000 DM

Default values: 400 DM

minimum running time

Setting range: 0 – 48 h

Default value: 12 h

min temp.

Setting range: 5 – 90 °C

Default value: 55 °C

mixing valve amplifier

Setting range: 0.1 –10.0

Default value: 1.0

mixing valve step delay

Setting range: 10 – 300 s

Default values: 30 s

Set when the addition is to start, the minimum run time and the minimum temperature for external addition with shunt here. External addition with shunt is for example a wood/oil/gas/pellet boiler.

You can set shunt valve amplification and shunt valve waiting time.

Selecting "prioritised additional heat" uses the heat from the external additional heat instead of the heat pump. The shunt valve is regulated as long as heat is available, otherwise the shunt valve is closed.



TIP

See the accessory installation instructions for function description.

MENU 5.3.3 - EXTRA CLIMATE SYSTEM

use in heating mode

Setting range: on/off

Factory setting: on

use in cooling mode

Setting range: on/off

Factory setting: off

mixing valve amplifier

Setting range: 0.1 – 10.0

Default value: 1.0

mixing valve step delay

Setting range: 10 – 300 s

Default values: 30 s

Contr. pump GP10

Setting range: on/off

Factory setting: off

Here, you select which climate system (2 - 8) you wish to set.

use in heating mode: If the heat pump is connected to a climate system(s) for cooling, any condensation can take place in this/these. Check that "use in heating mode" has been selected for the climate system(s) that is/are not adapted for cooling. This setting means that the sub-shunt for the extra climate system closes when cooling operation is activated.

use in cooling mode: Select "use in cooling mode" for climate systems that are adapted to handle cooling. For 2-pipe cooling you can select both "use in cooling mode" and "use in heating mode", while for 4-pipe cooling you can only select one option.



Caution

This setting option only appears if the heat pump is activated for cooling operation in menu 5.2.4..

mixing valve amplifier, mixing valve step delay: Here, you set the shunt amplification and shunt waiting time for the various extra climate systems that are installed.

Contr. pump GP10: Here, you can set the speed of the circulation pump manually.

See the accessory installation instructions for function description.

MENU 5.3.4 - SOLAR HEATING

start delta-T

Setting range: 1 – 40 °C

Default value: 8 °C

stop delta-T

Setting range: 0 – 40 °C

Default value: 4 °C

max. tank temperature

Setting range: 5 – 110 °C

Default value: 95 °C

max. solar collector temp.

Setting range: 80 – 200 °C

Default value: 125 °C

anti-freeze temperature

Setting range: -20 – +20 °C

Default value: 2 °C

start solar collector cooling

Setting range: 80 – 200 °C

Default value: 110 °C

passive recharging - activation temperature

Setting range: 50 – 125 °C

Factory setting: 110 °C

passive recharging - deactivation temperature

Setting range: 30 – 90 °C

Factory setting: 50 °C

active recharging - activating dT

Setting range: 8 – 60 °C

Factory setting: 40 °C

active recharging - deactivating dT

Setting range: 4 – 50 °C

Factory setting: 20 °C

start delta-T, stop delta-T: Here, you can set the temperature difference between solar panel and solar tank at which the circulation pump will start and stop.

max. tank temperature, max. solar collector temp.: Here, you can set the maximum temperatures in the tank and solar panel respectively at which the circulation pump will stop. This is to protect against excess temperatures in the solar tank.

If the unit has an anti-freeze function, solar panel cooling and/or passive/active recharging you can activate them here. When the function has been activated, you can make settings for them. "solar panel cooling", "passive recharging" and "active recharging" cannot be combined, only one function can be activated.

freeze protection

anti-freeze temperature: Here, you can set the temperature in the solar panel at which the circulation pump is to start to prevent freezing.

solar panel cooling

start solar collector cooling: If the temperature in the solar panel is higher than this setting, at the same time as the temperature in the solar tank is higher than the set maximum temperature, the external function for cooling is activated.

passive recharging

activation temperature: If the temperature in the solar panel is higher than this setting, the function is activated. However, the function is blocked for an hour if the temperature of the brine entering the heat pump (BT10) is higher than the set value for "max brine in" in menu 5.1.7.

deactivation temperature: If the temperature in the solar panel is lower than this setting, the function is deactivated.

active recharging

activating dT: If the difference between the temperature in the solar panel (BT53) and the temperature of the brine entering the heat pump (BT10) is greater than this setting, the function is activated. However, the function is blocked for an hour if the temperature of the brine entering the heat pump (BT10) is higher than the set value for "max brine in" in menu 5.1.7.

deactivating dT: If the difference between the temperature in the solar panel (BT53) and the temperature of the brine entering the heat pump (BT10) is lower than this setting, the function is deactivated.

See the accessory installation instructions for function description.

MENU 5.3.6 - STEP CONTROLLED ADD. HEAT

start diff additional heat

Setting range: 0 – 2000 DM

Default values: 400 DM

diff. between additional steps

Setting range: 0 – 1000 DM

Default values: 100 DM

max step

Setting range
(binary stepping deactivated): 0 – 3

Setting range
(binary stepping activated): 0 – 7

Default value: 3

binary stepping

Setting range: on/off

Factory setting: off

Make settings for step controlled addition here. Step controlled addition is for example an external electric boiler.

It is possible, for example, to select when the additional heat is to start, to set the maximum number of permitted steps and whether binary stepping is to be used.

When binary stepping is deactivated (off), the settings refer to linear stepping.

See the accessory installation instructions for function description.

MENU 5.3.8 - HOT WATER COMFORT

activating the mixing valve

Setting range: on/off

Factory setting: off

outgoing hot water

Setting range: 40 - 65 °C

Default value: 55 °C

mixing valve amplifier

Setting range: 0.1 – 10.0

Default value: 1.0

mixing valve step delay

Setting range: 10 – 300 s

Default values: 30 s

Make settings for the hot water comfort here.

See the accessory installation instructions for function description.

activating the mixing valve: Activated if mixer valve is installed and it is to be controlled from F1255. When the option is active, you can set the outgoing hot water temperature, shunt amplification and shunt waiting time for the mixer valve.

outgoing hot water: Here, you can set the temperature at which the mixer valve is to restrict hot water from the water heater.

MENU 5.3.11 - MODBUS

<i>address</i>
Factory setting: address 1
<i>word swap</i>
Factory setting: not activated

As from Modbus 40 version 10, the address can be set between 1 - 247. Earlier versions have a fixed address (address 1).

Here, you can select if you want to have "word swap" instead of the preset standard "big endian".

See the accessory installation instructions for function description.

MENY 5.3.12 - EXHAUST/SUPPLY AIR MODULE

<i>months btwn filter alarms</i>
Setting range: 1 – 24
Default value: 3
<i>lowest extract air temp.</i>
Setting range: 0 – 10 °C
Default value: 5 °C
<i>bypass at excess temperature</i>
Setting range: 2 – 10 °C
Default value: 4 °C
<i>bypass during heating</i>
Setting range: on/off
Factory setting: off
<i>cut-out value, exh. air temp.</i>
Setting range: 5 – 30 °C
Default value: 25 °C

months btwn filter alarms: Set how often the filter alarm is to be displayed.

lowest extract air temp.: Set the minimum extract air temperature to prevent the heat exchanger freezing.

bypass at excess temperature: If a room sensor is installed, set the excess temperature at which the bypass damper is to open here.



TIP

See the installation instructions for ERS and HTS for a function description.

MENU 5.3.15 - GBM COMMUNICATION MODULE

<i>start diff additional heat</i>
Setting range: 10 – 2,000 DM
Factory setting: 400 DM
<i>hysteresis</i>
Setting range: 10 – 2,000 DM
Factory setting: 100 DM

Make settings for the gas boiler GBM 10-15 here. For example . you can select when the gas boiler is to start. See the accessory installation instructions for a description of function.

MENU 5.3.16 - HUMIDITY SENSOR

<i>climate system 1 HTS</i>
Setting range: 1–4
Default value: 1
<i>limit RH in the room, syst.</i>
Setting range: on/off
Factory setting: off
<i>prevent condensation, syst.</i>
Setting range: on/off
Factory setting: off
<i>limit RH in the room, syst.</i>
Setting range: on/off
Factory setting: off

Up to four humidity sensors (HTS 40) can be installed. Here you select whether your system(s) is/are to limit the relative humidity level (RH) during heating or cooling operation.

You can also choose to limit min. cooling supply and calculated cooling supply to prevent condensation on pipes and components in the cooling system.

See the Installer Manual for HTS 40 for function description.

MENU 5.3.21 - FLOW SENSOR / ENERGY METER

Supply temperature sensor

set mode

Setting range: EMK150 / EMK300/310 / EMK500

Factory setting: EMK150

energy per pulse

Setting range: 0 – 10000 Wh

Factory setting: 1000 Wh

pulses per kWh

Setting range: 1 – 10000

Factory setting: 500

Energy meter

set mode

Setting range: energy per pulse / pulses per kWh

Default value: energy per pulse

energy per pulse

Setting range: 0 – 10000 Wh

Factory setting: 1000 Wh

pulses per kWh

Setting range: 1 – 10000

Factory setting: 500

Up to two flow sensors (EMK) / energy meters can be connected on the input board AA3, terminal block X22 and X23. Select these in menu 5.2.4 - accessories.

Flow sensor (Energy measurement kit EMK)

A flow sensor (EMK) is used to measure the amount of energy produced and supplied by the heating installation for hot water and heating in the building.

The function of the flow sensor is to measure flow and temperature differences in the charge circuit. The value is presented in the display on a compatible product.

energy per pulse: Here you set the amount of energy to which each pulse will correspond.

pulses per kWh: Here you set the number of pulses per kWh that are sent to F1255.

Energy meter (Electricity meter)

The energy meter(s) is used to send pulse signals every time a certain amount of energy has been consumed.

energy per pulse: Here you set the amount of energy to which each pulse will correspond.

pulses per kWh: Here you set the number of pulses per kWh that are sent to F1255.

MENU 5.4 - SOFT IN/OUTPUTS

Here you can select which input/output on the input board (AA3) the external contact function (page 27) must be connected to.

Selectable inputs on terminal block AUX 1-5 (AA3-X6:9-18) and output AA3-X7 on the input board.

MENU 5.5 - FACTORY SETTING SERVICE

All settings can be reset (including settings available to the user) to default values here.



Caution

When resetting, the start guide is displayed the next time the heat pump is restarted.

MENU 5.6 - FORCED CONTROL

You can force control the different components in the heat pump and any connected accessories here.



NOTE

Forced control is only intended to be used for troubleshooting purposes. Using the function in any other way may cause damage to the components in your climate system.

MENU 5.7 - START GUIDE

When the heat pump is started for the first time the start guide starts automatically. Start it manually here.

See page 33 for more information about the start guide.

MENU 5.8 - QUICK START

It is possible to start the compressor from here.



Caution

There must be a heating, cooling or hot water demand to start the compressor.



NOTE

Do not quick start the compressor too many times over a short period of time, as this could damage the compressor and its surrounding equipment.

MENU 5.9 - FLOOR DRYING FUNCTION

length of period 1 – 7

Setting range: 0 – 30 days

Factory setting, period 1 – 3, 5 – 7: 2 days

Factory setting, period 4: 3 days

temp. period 1 – 7

Setting range: 15 – 70 °C

Default value:

temp. period 1	20 °C
temp. period 2	30 °C
temp. period 3	40 °C
temp. period 4	45 C
temp. period 5	40 °C
temp. period 6	30 °C
temp. period 7	20 °C

Set the function for under floor drying here.

You can set up to seven period times with different calculated flow temperatures. If less than seven periods are to be used, set the remaining period times to 0 days.

Mark the active window to activate the underfloor drying function. A counter at the bottom shows the number of days the function has been active. The function counts degree minutes as during normal heating operation but for the supply temperatures that are set for the respective period.



NOTE

During under floor drying, the heating medium pump in 100% runs, regardless of the setting in menu 5.1.10.



TIP

If operating mode "add. heat only" is to be used, select it in menu 4.2.

For a more even flow temperature the addition can be started earlier by setting "start for addition" in menus 4.9.2 to -80. When set under floor drying periods have stopped, reset the menus 4.2 and 4.9.2 as per previous settings.



TIP

It is possible to save a floor drying log that shows when the concrete slab has reached the correct temperature. See section "Logging floor drying" on page 62.

The date, time, ID no. (unique to particular setting) and the new set value are shown for every change.



Caution

The change log is saved at restart and remains unchanged after factory setting.

MENU 5.10 - CHANGE LOG

Read off any previous changes to the control system here.

9 Service

Maintenance



NOTE

Maintenance may only be carried out by persons with the necessary expertise.

When replacing components on F1255 only replacement parts from NIBE may be used.



NOTE

If an electrical connection has been disconnected and is connected, ground must be checked using a suitable multimeter.



NOTE

An immersion heater without a temperature limiter is not allowed to be installed.



NOTE

Inspection of the water heater can be carried out via the flange located at the top of the water heater using an inspection instrument such as an endoscope.



NOTE

After servicing, complete the relevant Service Interval Record section of the Benchmark Checklist located at the back of this document.

Completion of the Service Interval Record is a condition of warranty. For full terms and conditions of warranty, please see our website nibe.co.uk.

GENERAL INSPECTION

Check the following:

1. Condition of casing.
2. Electrical connections.
3. Pipe connections.
4. Alarm log.

Correct any fault before continuing.

WATER HEATER

Check the following:

1. Hot water start and stop temperature.
2. Pressure controlled bypass valve.
3. T&P valve.
4. Overflow pipe.
5. Pressure expansion vessel.
6. Expansion relief valve.

Correct any fault before continuing.

BRINE SYSTEM

Check the following:

1. Particle filter.
2. Anti-freeze with suitable refractometer.
3. Expansion vessel.
4. System pressure.
5. Flow and return temperature. The difference must be 2 - 5 °C

Correct any fault before continuing.

CLIMATE SYSTEM

Check the following:

1. Climate system start and stop temperature.
2. Heating curve settings.
3. Function of the room sensor (if installed).
4. System pressure.
5. Flow and return temperature. The difference must be 5 - 10 °C

Correct any fault before continuing.

Service actions



NOTE

Servicing should only be carried out by persons with the necessary expertise.

When replacing components on F1255 only replacement parts from NIBE may be used.

EMERGENCY MODE



NOTE

The switch (SF1) must not be moved to "I" or "△" until F1255 has been filled with water. Component parts in the product can be damaged.

Emergency mode is used in event of operational interference and in conjunction with service. Hot water is not produced in emergency mode.

Emergency mode is activated by setting switch (SF1) in mode "△". This means that:

- The status lamp illuminates yellow.
- The display is not lit and the control computer is not connected.
- The temperature at the immersion heater is controlled by the thermostat (FQ10). It can be set either to 35 or 45 °C.
- The compressor and the brine system are off and only the heating medium pump and the electric additional heat are active. The additional heat power in emergency mode is set in the immersion heater board (AA1). See page 27 for instructions.

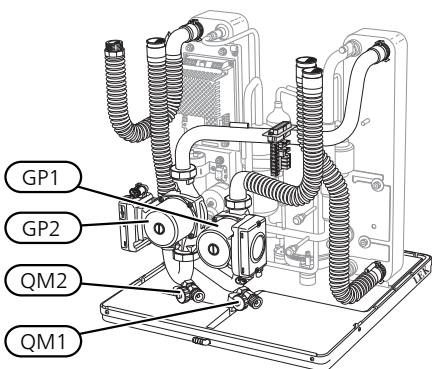

The image shows an example of what a cooling section could look like.

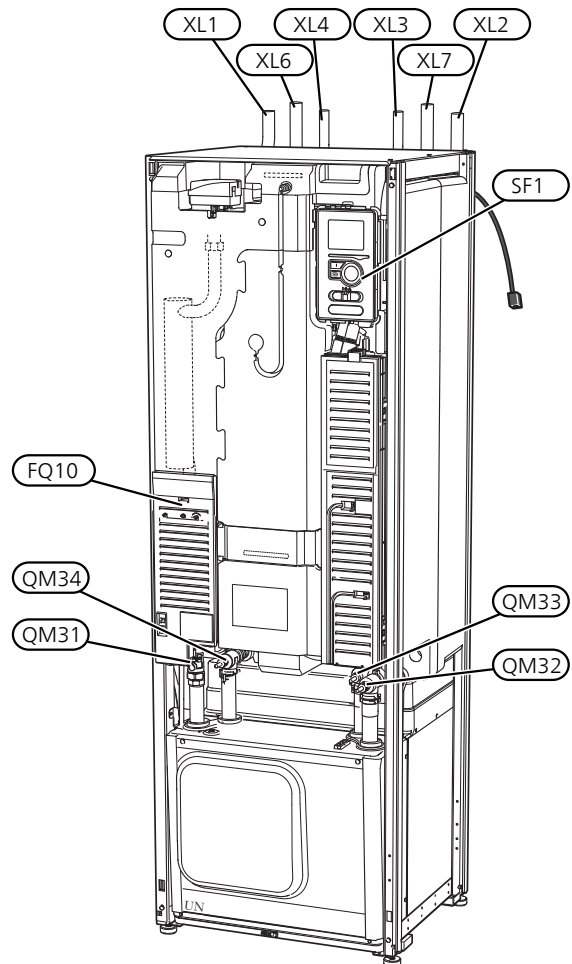

DRAINING THE HOT WATER HEATER

The siphon principle is used to empty the hot water heater. This can be done either via the drain valve on the incoming cold water pipe or by inserting a hose into the cold water connection.

CLEANING THE WATER HEATER

To clean the water heater, remove the upper panel and the insulation. Then open the flange for easy access.

DRAINING THE CLIMATE SYSTEM

In order to carry out service on the climate system, it may be easier to drain the system first. This can be done in different ways depending on what needs doing:



NOTE

There may be some hot water when draining the heating medium side/climate system. There is a risk of scalding.

Draining the heating medium side in the cooling module

If, for example, the heating medium pump requires replacing or the cooling module requires servicing, drain the heating medium side as follows:

1. Close the shut-off valves to heating medium side (QM31) and (QM32).

2. Connect a hose to the bleed valve (QM1) and open the valve. Some liquid will run out.
3. Air must get into the system for the remaining liquid to run out. To let in air, slacken off the connection slightly at the shut-off valve (QM32) that joins the heat pump with the cooling module.

When the heating medium side is empty, the required service can be carried out and/or replacement of any components carried out.

Draining the heating medium system in the heat pump

If F1255 requires servicing, drain the heating medium side as follows:

1. Close the shut-off valves outside the heat pump for the heating medium side (return and flow line).
2. Connect a hose to the bleed valve (QM1) and open the valve. Some liquid will run out.
3. Air must get into the system for the remaining liquid to run out. To let in air, slacken off the connection slightly at the shut-off valve that joins the heat pump with the cooling module (XL2).

When the heating medium side is empty, the required service can be carried out.

Draining the entire climate system

If the entire climate system requires draining, do this as follows:

1. Connect a hose to the bleed valve (QM1) and open the valve. Some liquid will run out.
2. Air must get into the system for the remaining liquid to run out. To allow air in, unscrew the bleed screw on the highest radiator in the house.

When the climate system is empty, the required service can be carried out.

EMPTYING THE BRINE SYSTEM

In order to service the brine system it may be easier to drain the system first. This can be done in different ways depending on what needs doing:

Draining the brine system in the cooling module

If, for example, the brine pump requires replacing or the cooling module requires servicing, drain the brine system by:

1. Close the shut-off valves to brine system (QM33) and (QM34).
2. Connect a hose to the drain valve (QM2), place the other opening of the hose in a container and open the valve. A small amount of brine will flow into the container.
3. Air must get into the system in order for the remaining brine to run out. To let in air, slacken off the connection slightly at the shut-off valve (QM33) that joins the heat pump with the cooling module.

When the brine system is empty, the required service can be carried out.

Draining the brine system in the heat pump

If the heat pump requires servicing, drain the brine system by:

1. Close the shut-off valve outside the heat pump for the brine system.
2. Connect a hose to the drain valve (QM2), place the other opening of the hose in a container and open the valve. A small amount of brine will flow into the container.
3. Air must get into the system for the remaining brine to run out. To let in air, slacken off the connection slightly at the shut-off valve that joins the brine side with the heat pump at connection (XL7).

When the brine system is empty, the required service can be carried out.

HELPING THE CIRCULATION PUMP TO START

1. Turn off F1255 by setting the switch (SF1) to "0".
2. Remove the front cover
3. Remove the cover for the cooling module.
4. Loosen the venting screw (QM5) with a screwdriver. Hold a cloth around the screwdriver blade as a small amount of water may run out.
5. Insert a screwdriver and turn the pump motor around.
6. Screw in the venting screw (QM5).
7. Start F1255 by setting the switch (SF1) to "I" and check that the circulation pump is working.

It is usually easier to start the circulation pump with F1255 running, and with the switch (SF1) set to "I". If the circulation pump is helped to start while F1255 is running, be prepared for the screwdriver to jerk when the pump starts.

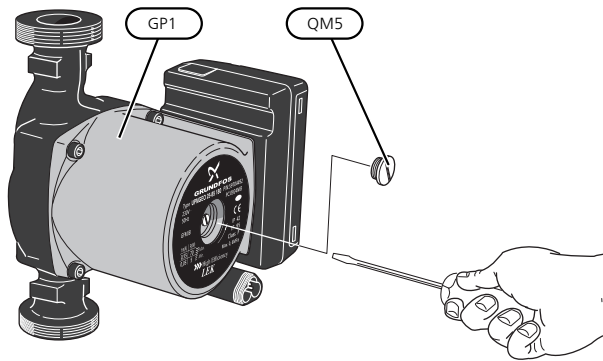

The image shows an example of what a circulation pump can look like.

TEMPERATURE SENSOR DATA

Temperature (°C)	Resistance (kOhm)	Voltage (VDC)
-40	351.0	3.256
-35	251.6	3.240
-30	182.5	3.218
-25	133.8	3.189
-20	99.22	3.150
-15	74.32	3.105
-10	56.20	3.047
-5	42.89	2.976
0	33.02	2.889
5	25.61	2.789
10	20.02	2.673
15	15.77	2.541
20	12.51	2.399
25	10.00	2.245
30	8.045	2.083
35	6.514	1.916
40	5.306	1.752
45	4.348	1.587
50	3.583	1.426
55	2.968	1.278
60	2.467	1.136
65	2.068	1.007
70	1.739	0.891
75	1.469	0.785
80	1.246	0.691
85	1.061	0.607
90	0.908	0.533
95	0.779	0.469
100	0.672	0.414

PULLING OUT THE COOLING MODULE

The cooling module can be pulled out for service and transport.



NOTE

Switch off the heat pump and cut the power with the safety switch.



Caution

Remove the front cover according to the description on page 9.

1. Close the shut-off valves (QM31), (QM32), (QM33) and (QM34).

Drain the compressor module according to the instructions on page 58

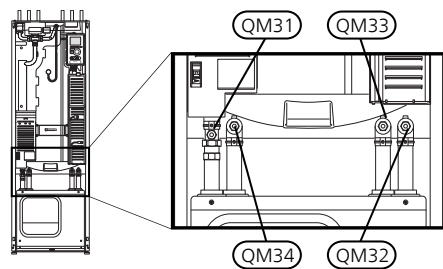

2. Pull off the lock catches.
3. Disconnect the pipe connection under the shut-off valve (QM31).

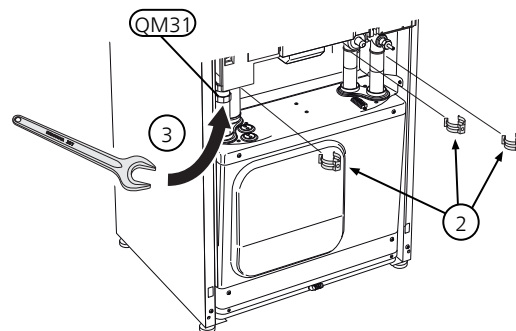

4. Remove the two screws.

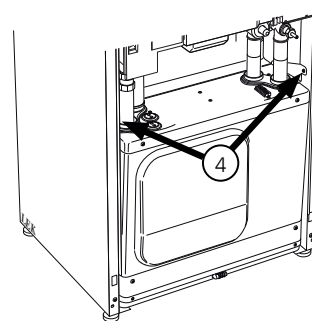

5. Remove the connection from the base card (AA2) using a screwdriver.

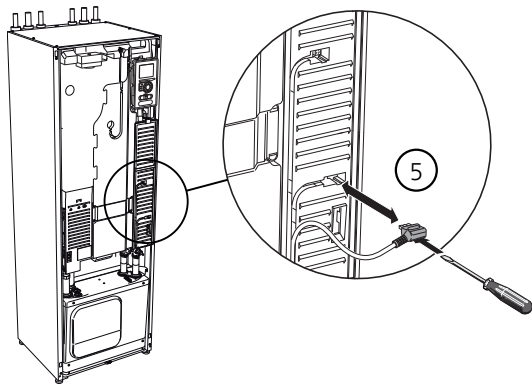

6. Disconnect the connectors (A) and (B) from the underside of the base card cabinet.
7. Disconnect the connector (C) from the electric addition PCB (AA1) using a screwdriver.
8. Disconnect the switch (D) from the joint board (AA100).
9. Carefully pull out the cooling module.

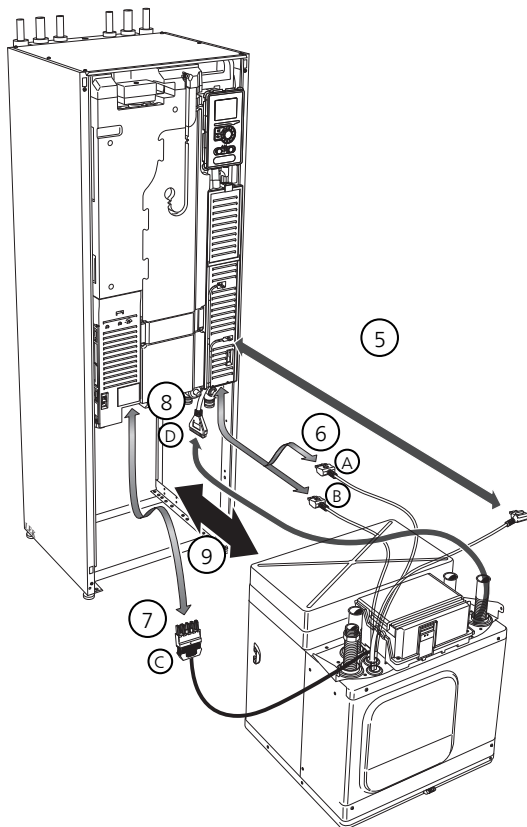

NOTE

At reinstallation, the supplied O-rings must replace the existing ones at the connections to the heat pump (see image).

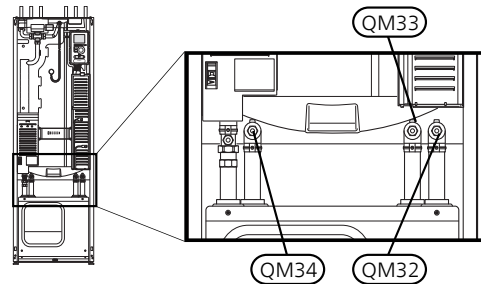

USB SERVICE OUTLET

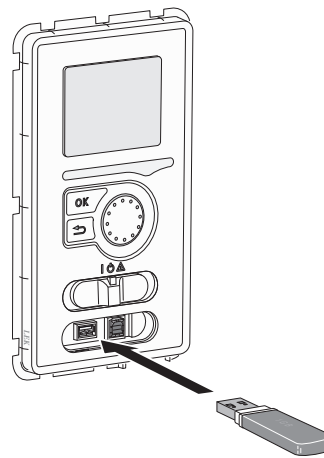

The display unit is equipped with a USB socket that can be used to update the software and save logged information in F1255.

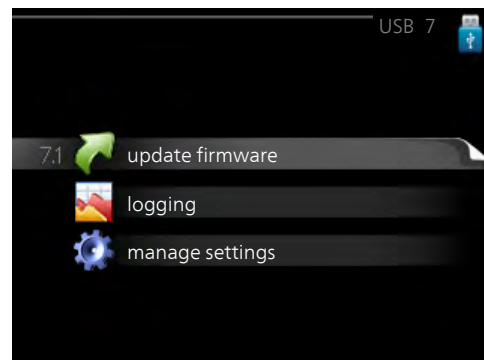
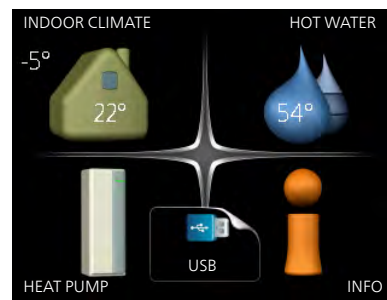

TIP

The cooling module is installed in reverse order.

When a USB memory is connected, a new menu (menu 7) appears in the display.

Menu 7.1 - update firmware

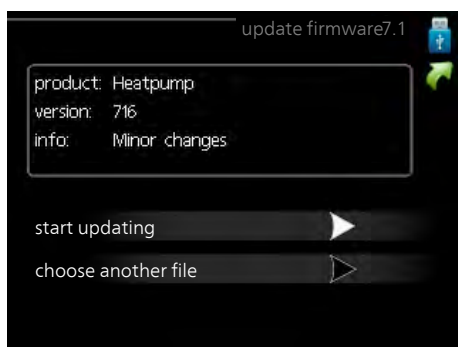

This allows you to update the software in F1255.



NOTE

For the following functions to work the USB memory must contain files with software for F1255 from NIBE.

The fact box at the top of the display shows information (always in English) of the most probable update that the update software has selected from the USB memory.

This information states the product for which the software is intended, the software version and general information about it. If you want a file other than the one selected, the correct file can be selected through "choose another file".

start updating

Select "start updating" if you want to start the update. You are asked whether you really want to update the software. Respond "yes" to continue or "no" to undo.

If you responded "yes" to the previous question the update starts and you can now follow the progress of the update on the display. When the update is complete F1255 restarts.



TIP

A software update does not reset the menu settings in F1255.



Caution

If the update is interrupted before it is complete (for example power cut etc.), the software can be reset to the previous version if the OK button is held in during start up until the green lamp starts to illuminate (takes about 10 seconds).

choose another file

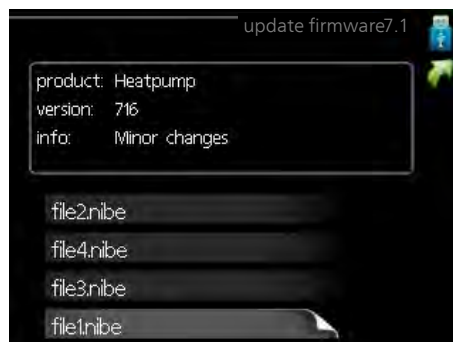

Select "choose another file" if you do not want to use the suggested software. When you scroll through the files, information about the marked software is shown in a fact box just as before. When you have selected a file with the OK button you will return to the previous page (menu 7.1) where you can choose to start the update.

Menu 7.2 - logging

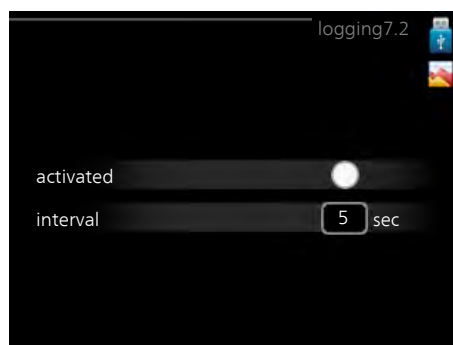

Setting range: 1 s – 60 min

Factory setting range: 5 s

Here you can choose how current measurement values from F1255 should be saved onto a log file on the USB memory.

1. Set the desired interval between loggings.
2. Tick "activated".
3. The present values from F1255 are saved in a file in the USB memory at the set interval until "activated" is unticked.



Caution

Untick "activated" before removing the USB memory.

Logging floor drying

Here you can save a floor drying log on the USB memory and in this way see when the concrete slab reached the correct temperature.

- Make sure that "floor drying function" is activated in menu 5.9.
- Select "logging floor drying activated".

- A log file is now created, where the temperature and the immersion heater output can be read off. Logging continues until "logging floor drying activated" is deselected or until "floor drying function" is stopped.



Caution

Deselect "logging floor drying activated" before you remove the USB memory.

Menu 7.3 - manage settings

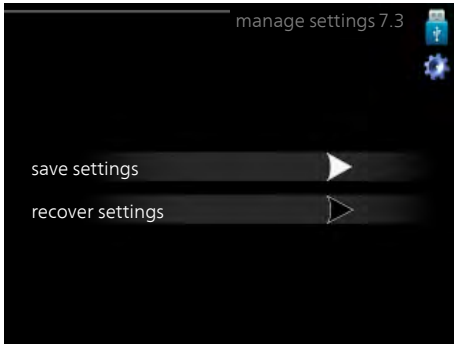

Here you can manage (save as or retrieve from) all the menu settings (user and service menus) in F1255 with a USB memory.

Via "save settings" you save the menu settings to the USB memory in order to restore them later or to copy the settings to another F1255.



Caution

When you save the menu settings to the USB memory you replace any previously saved settings on the USB memory.

Via "recover settings" you reset all menu settings from the USB memory.



Caution

Reset of the menu settings from the USB memory cannot be undone.

10 Disturbances in comfort

In most cases, F1255 notes a malfunction (a malfunction can lead to disruption in comfort) and indicates this with alarms, and instructions for action, in the display.

INFO MENU

All the heat pump measurement values are gathered under menu 3.1 in the heat pump menu system. Looking through the values in this menu can often simplify finding the source of the fault. See help menu or user manual for more information about menu 3.1.

Manage alarm

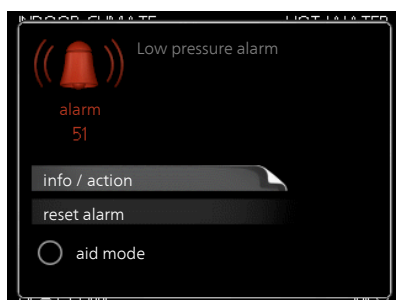

In the event of an alarm, some kind of malfunction has occurred, which is indicated by the status lamp changing from green continuously to red continuously. In addition, an alarm bell appears in the information window.

ALARM

In the event of an alarm with a red status lamp a malfunction has occurred that the heat pump cannot remedy itself. In the display, by turning the control knob and pressing the OK button, you can see the type of alarm it is and reset it. You can also choose to set the heat pump to aid mode.

info / action Here you can read what the alarm means and receive tips on what you can do to correct the problem that caused the alarm.

reset alarm In many cases, it is sufficient to select "reset alarm" for the product to revert to normal operation. If a green light comes on after selecting "reset alarm", the alarm has been remedied. If the red light is still on, and a menu called "alarm" is visible in the display, the problem causing the alarm still remains.

aid mode "aid mode" is a type of emergency mode. This means that the heat pump produces heat and/or hot water even though there is some kind of problem. This could mean that the heat pump's compressor is not running. In this case, the immersion heater produces heat and/or hot water.



Caution

To select aid mode an alarm action must be selected in the menu 5.1.4.



Caution

Selecting "aid mode" is not the same as correcting the problem that caused the alarm. The status lamp will therefore continue to be red.

Troubleshooting

If the operational interference is not shown in the display the following tips can be used:

BASIC ACTIONS

Start by checking the following items:

- The switch's (SF1) position.
- Group and main fuses of the accommodation.
- The property's earth circuit breaker.
- Miniature circuit breaker for F1255 (FC1).

LOW HOT WATER TEMPERATURE OR NO HOT WATER

- Mixing valve (if there is one installed) set too low.
 - Adjust the mixer valve.
- F1255 in incorrect operating mode.
 - Enter menu 4.2. If mode "auto" is selected, select a higher value on "stop additional heat" in menu 4.9.2.
 - If mode "manual" is selected, select "addition".
- Large hot water consumption.

- Wait until the hot water has heated up. Temporarily increased hot water capacity (temporary lux) can be activated in menu 2.1.
- Too low hot water setting.
 - Enter menu 2.2 and select a higher comfort mode.
- Too low or no operating prioritisation of hot water.
 - Enter menu 4.9.1 and increase the time for when hot water is to be prioritised. Note that, if the time for hot water is increased, the time for heating production is reduced, which can give lower/uneven room temperatures.

LOW ROOM TEMPERATURE

- Closed thermostats in several rooms.
 - Set the thermostats to max, in as many rooms as possible. Adjust the room temperature via menu 1.1, instead of choking the thermostats.
 - See the "Saving tips" section in the User manual for more detailed information about how to best set the thermostats.
- Too low set value on the automatic heating control.
 - Enter menu 1.1 "temperature" and adjust the offset heating curve up. If the room temperature is only low in cold weather the curve slope in menu 1.9.1 "heating curve" needs adjusting up.
- F1255 in incorrect operating mode.
 - Enter menu 4.2. If mode "auto" is selected, select a higher value on "stop heating" in menu 4.9.2.
 - If mode "manual" is selected, select "heating". If this is not enough, select "addition".
- Too low or no operating prioritisation of heat.
 - Enter menu 4.9.1 and increase the time for when heating is to be prioritised. Note that if the time for heating is increased the time for hot water production is reduced, which can give smaller amounts of hot water.
- "Holiday mode" activated in menu 4.7.
 - Enter menu 4.7 and select "Off".
- External switch for changing room temperature activated.
 - Check any external switches.
- Air in the climate system.
 - Vent the climate system (see page 32).
- Closed valves to the climate system.
 - Open the valves.

HIGH ROOM TEMPERATURE

- Too high set value on the automatic heating control.

- Enter menu 1.1 (temperature) and reduce the offset heating curve. If the room temperature is only high in cold weather the curve slope in menu 1.9.1 "heating curve" needs adjusting down.

- External switch for changing room temperature activated.
 - Check any external switches.

UNEVEN ROOM TEMPERATURE.

- Incorrectly set heating curve.
 - Fine-tune the heating curve in menu 1.9.1
- Too high set value on "dT at DOT"..
 - Enter menu 5.1.14 (flow set. climate system) and reduce the value of "dT at DOT".
- Uneven flow over the radiators.
 - Adjust the flow distribution between the radiators.

LOW SYSTEM PRESSURE

- Not enough water in the climate system.
 - Top up the water in the climate system (see page 32).

COMPRESSOR DOES NOT START

- There is no heating or cooling demand (accessory is required for cooling).
 - F1255 does not call on heating, cooling or hot water.
- Compressor blocked due to the temperature conditions.
 - Wait until the temperature is within the product's working range.
- Minimum time between compressor starts has not been reached.
 - Wait for at least 30 minutes and then check if the compressor has started.
- Alarm tripped.
 - Follow the display instructions.
- "Additional heat only" is selected.
 - Switch to "Auto" or "Manual" in menu 4.1 "Operating mode".

WHINING NOISE IN THE RADIATORS

- Closed thermostats in the rooms and incorrectly set heating curve.
 - Set the thermostats to max. in as many rooms as possible. Adjust the heating curve via menu 1.1, instead of choking the thermostats.

- Circulation pump speed set too high.
 - Enter menu 5.1.11 (pump speed heating medium) and reduce the speed of the circulation pump.
- Uneven flow over the radiators.
 - Adjust the flow distribution between the radiators.

GURGLING SOUND

This part of the troubleshooting chapter only applies if the NIBE FLM accessory is installed.

- Not enough water in the water seal.
 - Refill the water seal with water.
- Choked water seal.
 - Check and adjust the condensation water hose.

11 Accessories

ACCESSORY CARD AXC 40

This accessory is used to enable connection and control of shunt controlled additional heat, step controlled additional heat, external circulation pump or ground water pump.

Part no. 067 060

ACTIVE/PASSIVE COOLING HPAC 40

The accessory HPAC 40 is a climate exchange module that is to be included in a system with F1255.

Part no. 067 076

ACTIVE/PASSIVE COOLING IN 4-PIPE SYSTEM ACS 45

Part no 067 195

AUXILIARY RELAY HR 10

Auxiliary relay HR 10 is used to control external 1 to 3 phase loads such as oil burners, immersion heaters and pumps.

Part no 067 309

BASE EXTENSION EF 45

This accessory is used to create a larger connection area under F1255.

Part no. 067 152

BUFFER VESSEL UKV

UKV is an accumulator tank that is suitable for connection to a heat pump or another external heat source, and can have several different applications. It can also be used during external control of the heating system.

UKV 40

Part no. 088 470

UKV 200

Part no. 080 300

UKV 500

Part no. 080 114

UKV 100

Part no. 088 207

UKV 300

Part no. 080 301

COMMUNICATION MODULE FOR SOLAR ELECTRICITY EME 20

EME 20 is used to enable communication and control between inverters for solar cells from NIBE and F1255.

Part no. 057 188

COMMUNICATIONS MODULE MODBUS 40

MODBUS 40 enables F1255 to be controlled and monitored using a DUC (computer sub-centre) in the building. Communication is then performed using MODBUS-RTU.

Part no 067 144

COMMUNICATIONS MODULE SMS 40

When there is no internet connection, you can use the accessory SMS 40 to control F1255 via SMS.

Part no 067 073

ENERGY MEASUREMENT KIT EMK 300

This accessory is installed externally and used to measure the amount of energy that is supplied for the pool, hot water, heating and cooling in the building.

Cu pipe Ø22.

Part no. 067 314

EXHAUST AIR MODULE NIBE FLM

NIBE FLM is an exhaust air module designed to combine recovery of mechanical exhaust air with ground source heating.

NIBE FLM

Part no. 067 011

Bracket BAU 40

Part no. 067 666

EXTERNAL ELECTRIC ADDITIONAL HEAT ELK

These accessories require accessories card AXC 40 (step controlled addition).

ELK 5

Electric heater
5 kW
Part no. 069 025

ELK 8

Electric heater
8 kW
Part no. 069 026

ELK 15

15 kW, 3 x 400 V
Part no. 069 022

ELK 213

7-13 kW, 3 x 400 V
Part no. 069 500

EXTRA SHUNT GROUP ECS 40/ECS 41

This accessory is used when F1255 is installed in houses with two or more different heating systems that require different supply temperatures.

ECS 40 (Max 80 m²)

Part no 067 287

ECS 41 (approx. 80-250 m²)

Part no 067 288

FILLING VALVE KIT KB 32

Valve kit for filling brine in the collector hose. Includes particle filter and insulation.

KB 32 (max. 30 kW)

Part no 089 971

FREE COOLING PCS 44

This accessory is used when F1255 is installed in an installation with passive cooling.

Part no 067 296

GAS ACCESSORY

Communications module OPT 10

OPT 10 is used to enable connection and control of gas boiler NIBE GBM 10-15.

Part no. 067 513

HUMIDITY SENSOR HTS 40

This accessory is used to show and regulate humidity and temperatures during both heating and cooling operation.

Part no. 067 538

LEVEL MONITOR NV 10

Level monitor for extended checks of the brine level.

Part no. 089 315

MEASUREMENT KIT FOR SOLAR GENERATED ELECTRICITY EME 10

EME 10 is used to optimise the use of solar generated electricity. EME 10 measures the relevant current from the inverter via a current transformer and can work with all inverters.

Part no. 067 541

PASSIVE COOLING PCM 40/42

PCM 40/42 makes it possible to obtain passive cooling from rock, groundwater or surface soil collectors.

Part no. 067 077 / 067 078

POOL HEATING POOL 40

POOL 40 is used to enable pool heating with F1255.

Part no 067 062

ROOM UNIT RMU 40

The room unit is an accessory that allows the control and monitoring of F1255 to be carried out in a different part of your home to where it is located.

Part no 067 064

SOLAR PACKAGE NIBE PV

Solar panel package, 3 – 24 kW (10 – 80 panels), which is used to produce your own electricity.

VENTILATION HEAT EXCHANGER ERS

This accessory is used to supply the accommodation with energy that has been recovered from the ventilation air.

The unit ventilates the house and heats the supply air as necessary.

ERS 10-400

Part no. 066 115

ERS 20-250

Part no. 066 068

WATER HEATER/ACCUMULATOR TANK

VPA

Water heater with double-jacketed vessel.

VPA 300/200 Cu UK

Copper Part no. 082 024

VPB

Water heater without immersion heater with charging coil.

VPB 300 R UK

Stainless steel Part no. 081 081

VPB 500 UK

Copper Part no. 081 056

12 Technical data

Dimensions and setting-out coordinates

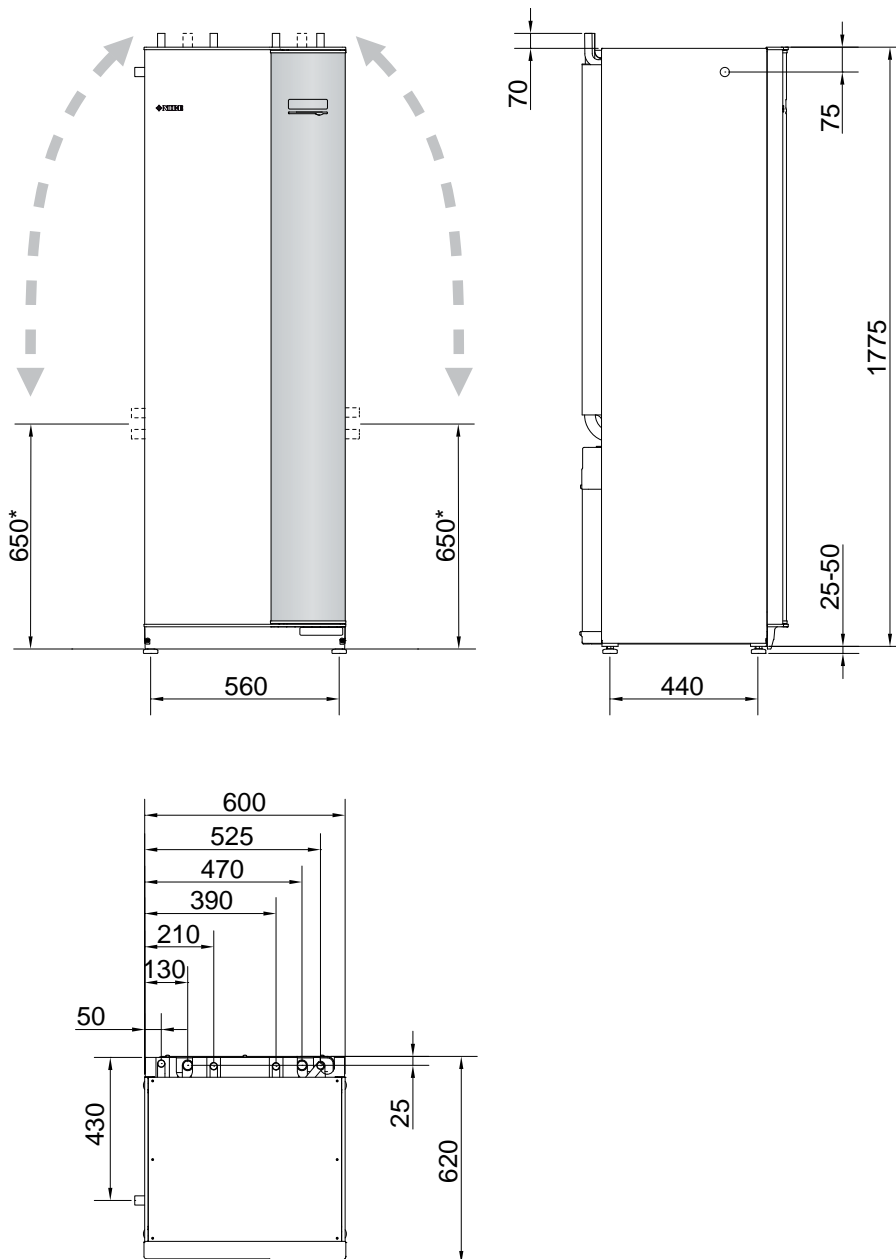

* This dimension applies at 90° angle on the brine pipes (side connection). The dimension can vary approx. ±100 mm vertically as the brine pipes consist in part of flexible pipes.

Electrical data

1X230V

F1255-6		
<i>Electrical data</i>		
Rated voltage		230V ~ 50Hz
Max operating current including 0 – 0.5 kW immersion heater (Recommended fuse rating).	A_{rms}	15(16)
Max operating current including 1 – 1.5 kW immersion heater (Recommended fuse rating).	A_{rms}	20(20)
Max operating current including 2 – 2.5 kW immersion heater (Recommended fuse rating).	A_{rms}	24(25)
Max operating current including 3 – 4 kW immersion heater (Recommended fuse rating).	A_{rms}	31(32)
Max operating current including 4.5 kW immersion heater (Recommended fuse rating).	A_{rms}	33(40)
<i>Additional power</i>	kW	0.5/1/1.5/2/2.5/3 /3.5/4/4.5

F1255-12		
<i>Electrical data</i>		
Rated voltage		230 V ~ 50 Hz
Max operating current including 0 – 1 kW immersion heater (Recommended fuse rating).	A_{rms}	26(32)
Max operating current including 2 – 4 kW immersion heater (Recommended fuse rating).	A_{rms}	39(40)
Max operating current including 5 – 7 kW immersion heater (Recommended fuse rating).	A_{rms}	52(63)
<i>Additional power</i>	kW	1/2/3/4/5/6/7

Technical specifications

1X230V

		F1255- 6	F1255- 12
<i>Output data according to EN 14511:2011</i>			
Heating capacity (P _H)	kW	1.5 – 6	3 – 12
<i>0/35 nominal</i>			
Rated output (P _H)	kW	3.15	5.06
Supplied power (P _E)	kW	0.67	1.04
COP		4.72	4.87
<i>0/45 nominal</i>			
Rated output (P _H)	kW	2.87	4.78
Supplied power (P _E)	kW	0.79	1.27
COP		3.61	3.75
<i>10/35 nominal</i>			
Rated output (P _H)	kW	4.30	6.33
Supplied power (P _E)	kW	0.66	1.03
COP		6.49	6.12
<i>10/45 nominal</i>			
Rated output (P _H)	kW	3.98	5.98
Supplied power (P _E)	kW	0.83	1.30
COP		4.79	4.59
<i>SCOP according to EN 14825</i>			
Nominal heating output (designh)	kW	6	12
SCOP _{EN14825} cold climate, 35 °C / 55 °C		5.5 / 4.1	5.4 / 4.3
SCOP _{EN14825} average climate, 35 °C / 55 °C		5.2 / 4.0	5.2 / 4.1
<i>Energy rating, average climate</i>			
Efficiency class room heating 35 °C / 55 °C ¹⁾		A+++ / A+++	A+++ / A+++
Space heating efficiency class of the system 35 °C / 55 °C ²⁾		A+++ / A+++	A+++ / A+++
Efficiency class hot water / charging profile ³⁾		A / XL	A / XL
<i>Noise</i>			
Noise output (L _{VWA}) according to EN 12102 at 0/35	dB(A)	36 – 43	36 – 47
Sound pressure level (L _{PA}) calculated values according to EN ISO 11203 at 0/35 and a distance of 1 m	dB(A)	21 – 28	21 – 32
<i>Electrical data</i>			
Output, Brine pump	W	10 – 87	3 – 180
Output, Heating medium pump	W	2 – 63	2 – 60
Enclosure class		IP21	
<i>Refrigerant circuit</i>			
Type of refrigerant		R407C	
GWP refrigerant		1,774	
Volume	kg	1.16	2.0
CO ₂ equivalent	ton	2.06	3.55
Cut-out value pressure switch HP / LP	MPa	3.2 (32 bar) / 0.15 (1.5 bar)	
Difference pressure switch HP / LP	MPa	-0.7 (-7 bar) / 0.15 (1.5 bar)	
<i>Brine circuit</i>			
Min/max system pressure brine	MPa	0.05 (0.5 bar) / 0.45 (4.5 bar)	
Nominal flow (50 Hz)	l/s	0.18	0.29
Max external avail. press at nom flow	kPa	64	115
Min/Max incoming Brine temp	°C	see diagram	
Min. outgoing brine temp.	°C	-12	
<i>Heating medium circuit</i>			
Min/Max system pressure heating medium	MPa	0.05 (0.5 bar) / 0.45 (4.5 bar)	
Nominal flow (50 Hz)	l/s	0.08	0.12
Max external avail. press at nom flow	kPa	69	73
Min/max HM-temp	°C	see diagram	
<i>Pipe connections</i>			
Brine ext diam. CU pipe	mm	28	
Heating medium ext diam. CU pipes	mm	22	28
Hot water connection external diam	mm	22	
Cold water connection external diam	mm	22	
<i>Water heater</i>			
Volume water heater	l	approx. 180	
Max pressure in water heater	MPa	0.6 (6 bar)	
<i>Capacity hot water heating (comfort mode Normal) According to EN16147</i>			
Amount of hot water (40 °C)		245	240
COP _{DHW} (load profile XL)		2.6	2.5
<i>Compressor oil</i>			
Oil type		POE	POE
Volume	l	0.68	0.9
<i>Dimensions and weight</i>			
Width	mm	600	
Depth	mm	620	
Height	mm	1,800	

		F1255- 6	F1255- 12
Required ceiling height ⁴⁾	mm	1,950	
Weight complete heat pump	kg	200	230
Weight only cooling module	kg	95	110
Part number, 1x230V		065 271	065 407

- 1)
Scale for the product's efficiency class room heating: A+++ to D.
- 2)
Scale for the system's efficiency class room heating: A+++ to G. Reported efficiency for the system takes the product's temperature regulator into account.
- 3)
Scale for efficiency class hot water: A+ to F.
- ⁴⁾With feet removed the height is approx. 1930 mm for F1255.

MISCELLANEOUS

Type		F1255-6/12
Capacity hot water heating according to EN 12 897		
Maximum water supply pressure	MPa (bar)	1.6 (16)
Operating pressure, tap water	MPa (bar)	0.6 (6)
Expansion vessel, tap water, precharge pressure	MPa (bar)	0.35 (3.5)
Pressure reduction valve, setting	MPa (bar)	0.3 (3.0)
Volume, water heater	litres	180
Volume primary, Heating medium coil	litres	10
Volume expansion vessel (external)	litres	18
Mass unit, filled with water	kg	414
Operating pressure (heating medium)	MPa (bar)	0.3 (3)
Max operating pressure of T&P-valve	MPa (bar)	0.7 (7)
Set opening pressure expansion valve tap water	MPa (bar)	0.6 (6)
Cut out, temperature limiter	C	89
Capacity coil, 15 °C to 60 °C, primary flow 900 l/h	kW	4.6
Reheating time F1255-12 kW	min	176 min
Volume of water drawn off, above 40 °C	litres	176
Pressure drop at 900 l/h	kPa	15
Heat loss	kWh/24h	2.06
Max temperature, heating fluid	°C	70
Max operating temperature T&P-valve	°C	95
Maximum power supply	kW	9.5
Discharge capacity of T&P-valve	kW	12

WORKING RANGE HEAT PUMP, COMPRESSOR OPERATION

The compressor provides a supply temperature up to 65 °C, at 0 °C incoming brine temperature, the remainder (up to 70°C) is obtained using the additional heat.

This diagram shows the working range below 75 % for F1255-6 and the entire working range for F1255-12.

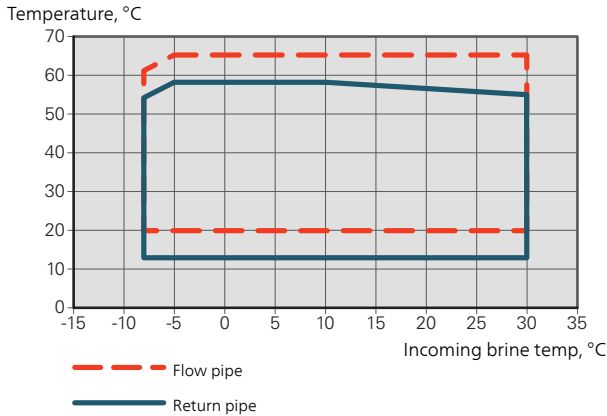

F1255-6

This diagram shows the working range above 75 % for F1255-6.

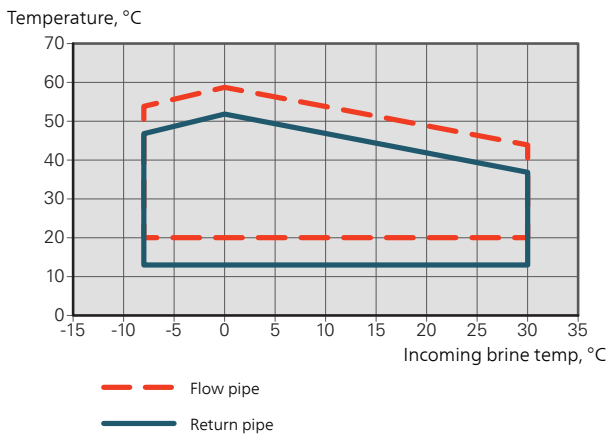

Caution

For operation of F1255-6 above 75% compressor speed, unlock in menu 5.1.24. This can produce a louder noise level than the value stated in the technical specifications.

DIAGRAM, DIMENSIONING COMPRESSOR SPEED

Heating mode 35 °C

Use this diagram to dimension the heat pump. The percentages show approximate compressor speed.

F1255-6

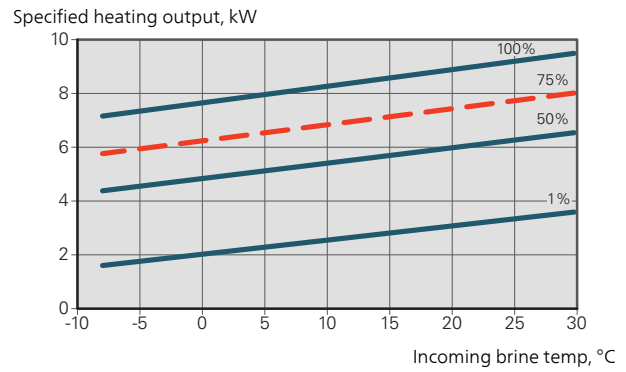

F1255-12

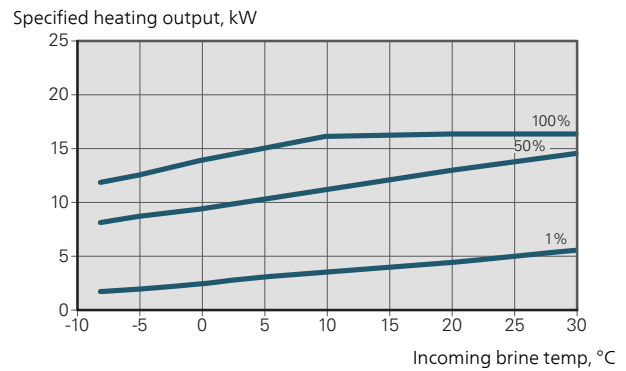

Cooling mode (Accessory required)



Caution

To dimension heating dump, see the diagram for heating operation.

Supply temperature, heating medium 35 °C

F1255-6

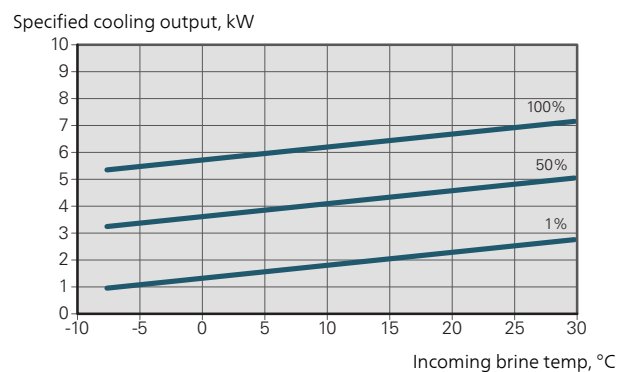

F1255-12

Specified cooling output, kW

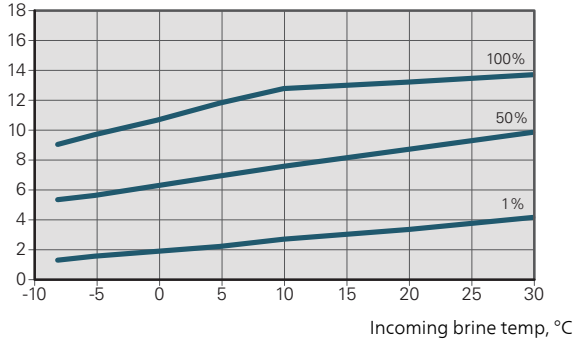

Supply temperature, heating medium 50 °°C

F1255-6

Specified cooling output, kW

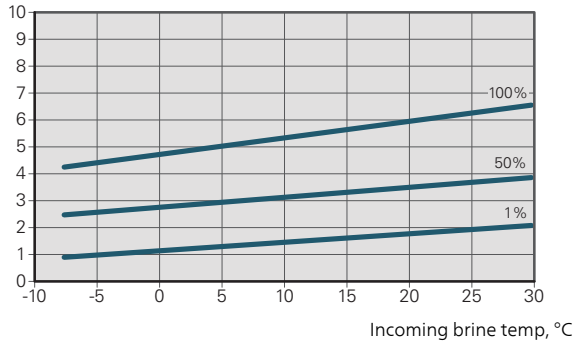

F1255-12

Specified cooling output, kW

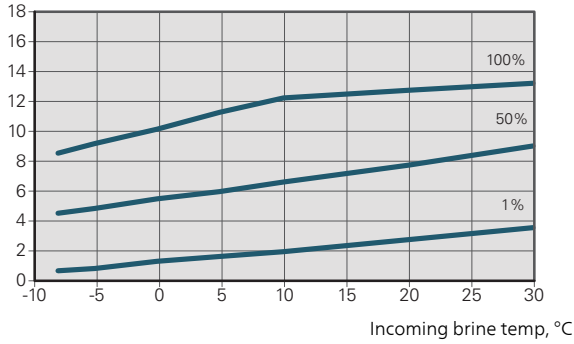

Energy labelling

INFORMATION SHEET

Supplier		NIBE AB	
Model		F1255-6	F1255-12
Temperature application	°C	35 / 55	35 / 55
Declared load profile for water heating		XL	XL
Seasonal space heating energy efficiency class, average climate		A+++ / A+++	A+++ / A+++
Water heating energy efficiency class, average climate		A	A
Rated heat output ($P_{\text{design,h}}$), average climate	kW	6	12
Annual energy consumption space heating, average climate	kWh	2,188 / 2,875	4,582 / 6,213
Annual energy consumption water heating, average climate	kWh	1,642	1,709
Seasonal space heating energy efficiency, average climate	%	200 / 150	201 / 157
Water heating energy efficiency, average climate	%	102	98
Sound power level L_{WA} indoors	dB	42	44
Rated heat output ($P_{\text{design,h}}$), cold climate	kW	6	12
Rated heat output ($P_{\text{design,h}}$), warm climate	kW	6	12
Annual energy consumption space heating, cold climate	kWh	2,481 / 3,287	5,292 / 7,173
Annual energy consumption water heating, cold climate	kWh	1,642	1,709
Annual energy consumption space heating, warm climate	kWh	1,408 / 1,852	2,928 / 3,999
Annual energy consumption water heating, warm climate	kWh	1,642	1,709
Seasonal space heating energy efficiency, cold climate	%	211 / 157	208 / 162
Water heating energy efficiency, cold climate	%	102	98
Seasonal space heating energy efficiency, warm climate	%	201 / 151	204 / 158
Water heating energy efficiency, warm climate	%	102	98
Sound power level L_{WA} outdoors	dB	-	-

DATA FOR ENERGY EFFICIENCY OF THE PACKAGE

Model		F1255-6	F1255-12
Temperature application	°C	35 / 55	35 / 55
Controller, class		VI	
Controller, contribution to efficiency	%	4	
Seasonal space heating energy efficiency of the package, average climate	%	204 / 154	205 / 161
Seasonal space heating energy efficiency class of the package, average climate		A+++	A+++
Seasonal space heating energy efficiency of the package, cold climate	%	215 / 161	212 / 166
Seasonal space heating energy efficiency of the package, warm climate	%	205 / 155	208 / 162

The reported efficiency of the package also takes the controller into account. If an external supplementary boiler or solar heating is added to the package, the overall efficiency of the package should be recalculated.

TECHNICAL DOCUMENTATION

Model		F1255-6					
Type of heat pump	<input type="checkbox"/> Air-water <input type="checkbox"/> Exhaust-water <input checked="" type="checkbox"/> Brine-water <input type="checkbox"/> Water-water						
Low-temperature heat pump	<input type="checkbox"/> Yes <input checked="" type="checkbox"/> No						
Integrated immersion heater for additional heat	<input checked="" type="checkbox"/> Yes <input type="checkbox"/> No						
Heat pump combination heater	<input checked="" type="checkbox"/> Yes <input type="checkbox"/> No						
Climate	<input checked="" type="checkbox"/> Average <input type="checkbox"/> Cold <input type="checkbox"/> Warm						
Temperature application	<input checked="" type="checkbox"/> Average (55 °C) <input type="checkbox"/> Low (35 °C)						
Applied standards	EN-14825 & EN-16147						
Rated heat output	Prated	5,5	kW	Seasonal space heating energy efficiency	η_s	150	%
Declared capacity for space heating at part load and at outdoor temperature T_j				Declared coefficient of performance for space heating at part load and at outdoor temperature T_j			
$T_j = -7\text{ °C}$	Pdh	5.0	kW	$T_j = -7\text{ °C}$	COPd	3.06	-
$T_j = +2\text{ °C}$	Pdh	3.0	kW	$T_j = +2\text{ °C}$	COPd	3.97	-
$T_j = +7\text{ °C}$	Pdh	2.0	kW	$T_j = +7\text{ °C}$	COPd	4.63	-
$T_j = +12\text{ °C}$	Pdh	1.2	kW	$T_j = +12\text{ °C}$	COPd	4.86	-
$T_j = \text{biv}$	Pdh	5.4	kW	$T_j = \text{biv}$	COPd	2.84	-
$T_j = \text{TOL}$	Pdh	5.4	kW	$T_j = \text{TOL}$	COPd	2.84	-
$T_j = -15\text{ °C}$ (if $\text{TOL} < -20\text{ °C}$)	Pdh		kW	$T_j = -15\text{ °C}$ (if $\text{TOL} < -20\text{ °C}$)	COPd		-
Bivalent temperature	T_{biv}	-10	°C	Min. outdoor air temperature	TOL	-10	°C
Cycling interval capacity	P _{psych}		kW	Cycling interval efficiency	COP _{psych}		-
Degradation coefficient	Cdh	0.99	-	Max supply temperature	WTOL	65	°C
<i>Power consumption in modes other than active mode</i>				<i>Additional heat</i>			
Off mode	P _{OFF}	0.002	kW	Rated heat output	P _{sup}	0.1	kW
Thermostat-off mode	P _{TO}	0.007	kW	Type of energy input Electric			
Standby mode	P _{SB}	0.007	kW				
Crankcase heater mode	P _{CK}	0.009	kW				
<i>Other items</i>							
Capacity control	Variable			Rated airflow (air-water)			m ³ /h
Sound power level, indoors/outdoors	L _{WA}	42 / -	dB	Nominal heating medium flow			m ³ /h
Annual energy consumption	Q _{HE}	2,875	kWh	Brine flow brine-water or water-water heat pumps		0.68	m ³ /h
<i>For heat pump combination heater</i>							
Declared load profile for water heating	XL			Water heating energy efficiency	η_{wh}	102	%
Daily energy consumption	Q _{elec}	7.73	kWh	Daily fuel consumption	Q _{fuel}		kWh
Annual energy consumption	AEC	1,642	kWh	Annual fuel consumption	AFC		GJ
Contact information	NIBE Energy Systems – Box 14 – Hannabadsvägen 5 – 285 21 Markaryd – Sweden						

Model				F1255-12			
Type of heat pump	<input type="checkbox"/> Air-water <input type="checkbox"/> Exhaust-water <input checked="" type="checkbox"/> Brine-water <input type="checkbox"/> Water-water						
Low-temperature heat pump	<input type="checkbox"/> Yes <input checked="" type="checkbox"/> No						
Integrated immersion heater for additional heat	<input checked="" type="checkbox"/> Yes <input type="checkbox"/> No						
Heat pump combination heater	<input checked="" type="checkbox"/> Yes <input type="checkbox"/> No						
Climate	<input checked="" type="checkbox"/> Average <input type="checkbox"/> Cold <input type="checkbox"/> Warm						
Temperature application	<input checked="" type="checkbox"/> Average (55 °C) <input type="checkbox"/> Low (35 °C)						
Applied standards	EN-14825 & EN-16147						
Rated heat output	Prated	12,4	kW	Seasonal space heating energy efficiency	η_s	157	%
Declared capacity for space heating at part load and at outdoor temperature T_j				Declared coefficient of performance for space heating at part load and at outdoor temperature T_j			
$T_j = -7\text{ °C}$	Pdh	11.1	kW	$T_j = -7\text{ °C}$	COPd	3.18	-
$T_j = +2\text{ °C}$	Pdh	6.8	kW	$T_j = +2\text{ °C}$	COPd	4.12	-
$T_j = +7\text{ °C}$	Pdh	4.4	kW	$T_j = +7\text{ °C}$	COPd	4.67	-
$T_j = +12\text{ °C}$	Pdh	2.6	kW	$T_j = +12\text{ °C}$	COPd	5.06	-
$T_j = \text{biv}$	Pdh	12.3	kW	$T_j = \text{biv}$	COPd	2.91	-
$T_j = \text{TOL}$	Pdh	12.3	kW	$T_j = \text{TOL}$	COPd	2.91	-
$T_j = -15\text{ °C}$ (if TOL < -20 °C)	Pdh		kW	$T_j = -15\text{ °C}$ (if TOL < -20 °C)	COPd		-
Bivalent temperature	T_{biv}	-10	°C	Min. outdoor air temperature	TOL	-10	°C
Cycling interval capacity	Pcyc		kW	Cycling interval efficiency	COPcyc		-
Degradation coefficient	Cdh	0.99	-	Max supply temperature	WTOL	65	°C
Power consumption in modes other than active mode				Additional heat			
Off mode	P_{OFF}	0.005	kW	Rated heat output	P_{sup}	0.1	kW
Thermostat-off mode	P_{TO}	0.015	kW				
Standby mode	P_{SB}	0.007	kW	Type of energy input	Electric		
Crankcase heater mode	P_{CK}	0.0	kW				
Other items							
Capacity control	Variable			Rated airflow (air-water)			m ³ /h
Sound power level, indoors/outdoors	L_{WA}	44 / -	dB	Nominal heating medium flow			m ³ /h
Annual energy consumption	Q_{HE}	6,213	kWh	Brine flow brine-water or water-water heat pumps		1.46	m ³ /h
For heat pump combination heater							
Declared load profile for water heating	XL			Water heating energy efficiency	η_{wh}	98	%
Daily energy consumption	Q_{elec}	7.78	kWh	Daily fuel consumption	Q_{fuel}		kWh
Annual energy consumption	AEC	1,709	kWh	Annual fuel consumption	AFC		GJ
Contact information	NIBE Energy Systems – Box 14 – Hannabadvägen 5 – 285 21 Markaryd – Sweden						

Item register

A

Accessibility, electrical connection, 24
Accessories, 67
Alarm, 64
Areas with hard water, 18
Assembly, 8

B

Back button, 38
Brine side, 19

C

Cable lock, 25
Cleaning the climate system, 18
Cleaning the water heater, 58
Cold and hot water, 20
 Connecting cold and hot water, 20
Commissioning and adjusting, 32
 Filling and venting, 32
 Post adjustment and bleeding, 34
 Preparations, 32
 Start guide, 33
Connecting accessories, 30
Connecting the climate system, 20
Connections, 25
Control, 38, 43
 Control - Introduction, 38
 Control - Menus, 43
Control - Introduction, 38
 Display unit, 38
 Menu system, 39
Control knob, 38
Controlling ground water pump, 30
Control - Menus, 43
 Menu 5 - SERVICE, 45
Cooling mode indication, 30
Cooling section, 14
Country specific information, 6

D

Data for energy efficiency of the system, 75
Delivery and handling, 8
 Assembly, 8
 Drawing out the cooling module, 8
 Installation area, 8
 Removing parts of the insulation, 10
 Removing the covers, 9
 Supplied components, 9
 Transport, 8

Diagram, dimensioning compressor speed, 73

Dimensions and pipe connections, 19

Dimensions and setting-out coordinates, 69

Display, 38

Display unit, 38

 Back button, 38

 Control knob, 38

 Display, 38

 OK button, 38

 Status lamp, 38

 Switch, 38

Disturbances in comfort, 64

 Alarm, 64

 Manage alarm, 64

 Troubleshooting, 64

Docking alternatives, 20

 Free cooling, 21

 Ground water system, 21

 Neutralization vessel, 21

 Pool, 22

 Two or more climate systems, 22

 Ventilation recovery, 21

Draining the climate system, 58

Draining the hot water heater, 58

Drawing out the cooling module, 8, 60

E

Electrical addition - maximum output, 26

 Setting max electrical output, 26

Electrical cabinets, 13

Electrical connections, 23

 Accessibility, electrical connection, 24

 Cable lock, 25

 Connecting accessories, 30

 Connections, 25

 Electrical addition - maximum output, 26

 External connection options, 28

 General, 23

 Master/Slave, 27

 Miniature circuit-breaker, 23

 NIBE Uplink, 28

 Optional connections, 27

 Outdoor sensor, 26

 Power connection, 25

 Removing the cover, base board, 24

 Removing the cover, immersion heater circuit board, 24

 Removing the hatch, input circuit board, 24

- Room sensor, 26
- Settings, 26
- Standby mode, 27
- Temperature limiter, 23
- Temperature limiter, compressor, 23
- Temperature sensor, external flow line, 26
- Emptying the brine system, 59
- Energy labelling, 75
 - Data for energy efficiency of the package, 75
 - Information sheet, 75
 - Technical documentation, 76
- External connection options, 28
 - Controlling ground water pump, 30
 - Cooling mode indication, 30
 - Extra circulation pump, 30
 - Hot water circulation, 30
 - Possible selection for AUX inputs, 28
 - Possible selection for AUX output (potential free variable relay), 30
- Extra circulation pump, 30

F

- Filling and venting, 32
 - Filling and venting the brine system, 33
 - Filling and venting the climate system, 32
 - Filling the hot water heater, 32
- Filling and venting the brine system, 33
- Filling and venting the climate system, 32
- Filling the hot water heater, 32

H

- Heating medium side, 20
 - Connecting the climate system, 20
- Helping the circulation pump to start, 59
- Help menu, 42
- Hot water circulation, 30

I

- Important information, 4
 - Country specific information, 6
 - Recovery, 5
- Information sheet, 75
- Inspection of the installation, 7
- Installation alternative
 - Water heater with immersion heater, 21
- Installation area, 8

M

- Manage alarm, 64
- Marking, 4
- Menu 5 - SERVICE, 45
- Menu system, 39
 - Help menu, 42
 - Operation, 41
 - Scroll through the windows, 42
 - Selecting menu, 41
 - Selecting options, 41
 - Setting a value, 41
 - Use the virtual keyboard, 42
- Miniature circuit-breaker, 23

N

- NIBE Uplink, 28

O

- OK button, 38
- Operation, 41
- Optional connections, 27
- Outdoor sensor, 26

P

- Pipe connections, 16
 - Brine side, 19
 - Cold and hot water
 - Connecting cold and hot water, 20
 - Dimensions and pipe connections, 19
 - Docking alternatives, 20
 - General, 16
 - Areas with hard water, 18
 - Cleaning the climate system, 18
 - Heating medium side, 20
 - Pipe dimensions, 19
 - Symbol key, 18
 - System diagram, 18
- Pipe dimensions, 19
- Possible selection for AUX inputs, 28
- Possible selection for AUX output (potential free variable relay), 30
- Post adjustment and bleeding, 34
 - Pump adjustment, automatic operation, 34
 - Pump adjustment, manual operation, 34
 - Pump capacity diagram, brine side, manual operation, 34
 - Readjusting, venting, heat medium side, 35
- Power connection, 25
- Preparations, 32
- Pump adjustment, automatic operation, 34
 - Brine side, 34
 - Heating medium side, 34
- Pump adjustment, manual operation, 34
 - Heating medium side, 34
- Pump capacity diagram, brine side, manual operation, 34

R

- Readjusting, venting, heat medium side, 35
- Remove parts of the insulation, 10
- Removing the cover, base board, 24
- Removing the cover, immersion heater circuit board, 24
- Removing the covers, 9
- Removing the hatch, input circuit board, 24
- Room sensor, 26

S

- Safety information
 - Inspection of the installation, 7
 - Marking, 4
 - Serial number, 5
 - Symbols, 4
 - Warranty information, 6
- Scroll through the windows, 42
- Selecting menu, 41
- Selecting options, 41

- Serial number, 5
- Service, 57
 - Service actions, 58
- Service actions, 58
 - Cleaning the water heater, 58
 - Draining the climate system, 58
 - Draining the hot water heater, 58
 - Drawing out the cooling module, 60
 - Emptying the brine system, 59
 - Helping the circulation pump to start, 59
 - Standby mode, 58
 - Temperature sensor data, 60
 - USB service outlet, 61
- Setting a value, 41
- Settings, 26
- Standby mode, 58
 - Power in emergency mode, 27
- Start guide, 33
- Status lamp, 38
- Supplied components, 9
- Switch, 38
- Symbol key, 18
- Symbols, 4
- System diagram, 18

T

- Technical data, 69
 - Dimensions and setting-out coordinates, 69
 - Energy labelling, 75
 - Data for energy efficiency of the system, 75
 - Information sheet, 75
 - Technical documentation, 76
 - Technical Data, 71
- Technical Data, 71
 - Diagram, dimensioning compressor speed, 73
 - Working range heat pump, 73
- Technical documentation, 76
- Temperature limiter, 23
 - Resetting, 23
- Temperature limiter, compressor, 23
 - Resetting, 23
- Temperature sensor, external flow line, 26
- Temperature sensor data, 60
- The heat pump design, 11
 - Component list cooling section, 14
 - Component list electrical cabinets, 13
 - Component location cooling section, 14
 - Component location electrical cabinets, 13
 - Component locations, 11
 - List of components, 11
- Transport, 8
- Troubleshooting, 64

U

- USB service outlet, 61
- Use the virtual keyboard, 42

W

- Warranty information, 6
- Working range heat pump, 73

GROUND SOURCE HEAT PUMP COMMISSIONING CHECKLIST

This Commissioning Checklist is to be completed in full by the competent person who commissioned the heat pump and associated equipment as a means of demonstrating compliance with the appropriate Building Regulations and then handed to the customer to keep for future reference. Failure to install and commission this equipment to the manufacturer's instructions may invalidate the warranty but does not affect statutory rights

Customer Name _____
 Address _____ Telephone Number _____

Heat Pump Make and Model _____

Heat Pump Serial Number

--	--	--	--	--	--	--	--	--	--	--	--	--	--	--	--	--	--	--	--

Commissioned by (print name) _____ Certified Operative Reg. No. [1] _____
 Company Name & Address _____ Commissioning Date _____ Telephone No. _____

Building Regulations Notification Number (if applicable) [2] _____

CONTROLS - SYSTEM AND HEAT PUMP Tick the appropriate boxes if applicable

1. Time & Temperature Control to Heating	Room Thermostat & Programmer/Timer <input type="checkbox"/>	Programmable Roomstat <input type="checkbox"/>	Load/Weather Compensation <input type="checkbox"/>	Optimum Start Control <input type="checkbox"/>
2. Time & Temperature Control to Hot Water			Cylinder Thermostat & Programmer/Timer <input type="checkbox"/>	Combined with Heat pump main controls <input type="checkbox"/>
3. Heating Zone Valves (including underfloor loops)			Fitted <input type="checkbox"/>	Not Required <input type="checkbox"/>
4. Hot Water Zone Valves			Fitted <input type="checkbox"/>	Not Required <input type="checkbox"/>
5. Thermostatic Radiator Valves			Fitted <input type="checkbox"/>	Not Required <input type="checkbox"/>
6. Heat Pump Safety Interlock [3]			Built In <input type="checkbox"/>	Provided <input type="checkbox"/>
7. Outdoor Sensor			Fitted <input type="checkbox"/>	Not Required <input type="checkbox"/>
8. Automatic Bypass System			Fitted <input type="checkbox"/>	Not Required <input type="checkbox"/>
9. Buffer Vessel Fitted			Yes <input type="checkbox"/> No <input type="checkbox"/> If YES, Volume _____ Litres	

ALL SYSTEMS

The heating system has been filled and pressure tested Yes

Expansion vessel for heating is sized, fitted & charged in accordance with manufacturer's instructions Yes

The heat pump is fitted on a solid/stable surface capable of taking its weight Yes

The system has been flushed and cleaned in accordance with BS7593 and heat pump manufacturer's instructions Yes

What system cleaner was used? _____

What inhibitor was used? Qty _____ litres

Are all exposed external pipeworks insulated? Yes

BORE HOLE/GROUND LOOPS

Bore Hole Ground Loop Length/Depth _____ m

The ground loops/bore hole pipes have been filled and pressure tested in accordance with relevant British Standards Yes

If more than one collector has been used has the system been hydraulically balanced (Flow balancing/regulating valves fitted & adjusted)? Yes

Has the system been vented/de-aired? Yes

Are system filters fitted & clean? Yes

Is the system topped up to the correct level? Yes

Was the system cleaned & flushed prior to use? Yes

Are isolating valves in their correct position Yes

What system cleaner was used? Qty _____ litres

What antifreeze was used? Qty _____ litres

What temperature will the antifreeze protect to? _____ °C

What inhibitor was used (if not included in Antifreeze)? Qty _____ litres

Record incoming collector fluid temperature _____ °C

Record outgoing collector fluid temperature _____ °C

CENTRAL HEATING MODE Measure and Record

Heating Flow Temperature _____ °C Heating Return Temperature _____ °C

DOMESTIC HOT WATER MODE Measure and Record

Is the heat pump connected to a hot water cylinder? Unvented Vented Thermal Store Not Connected

Hot water has been checked at all outlets Yes Have Thermostatic Blending Valves been fitted? Yes Not required

ADDITIONAL SYSTEM INFORMATION

Additional heat sources connected: Gas Boiler Oil Boiler Electric Heater Solar Thermal Other _____

ALL INSTALLATIONS

The heating, hot water and ventilation systems complies with the appropriate Building Regulations Yes

All electrical work complies with the appropriate Regulations Yes

The heat pump and associated products have been installed and commissioned in accordance with the manufacturer's instructions Yes

The operation of the heat pump and system controls have been demonstrated to the customer Yes

The manufacturer's literature, including Benchmark Checklist and Service Record, has been explained and left with the customer Yes

Commissioning Engineer's Signature _____
 Customer's Signature _____
 (To confirm demonstration of equipment and receipt of appliance instructions)

Notes: [1] Installers should be members of an appropriate Competent Persons Scheme. [2] All installations in England and Wales must be notified to Local Area Building Control (LABC) either directly or through a Competent Persons Scheme. A Building Regulations Compliance Certificate will then be issued to the customer. [3] May be required for systems covered by G3 Regulations



Service Record

It is recommended that your heating system is serviced regularly and that the appropriate Service Interval Record is completed.

Service Provider

Before completing the appropriate Service Interval Record below, please ensure you have carried out the service as described in the manufacturer's instructions.

Always use the manufacturer's specified spare part when replacing controls.

Service 1

Date: _____

Engineer Name: _____

Company Name: _____

Telephone No. _____

Operative ID No. _____

Comments: _____

Signature: _____

Service 2

Date: _____

Engineer Name: _____

Company Name: _____

Telephone No. _____

Operative ID No. _____

Comments: _____

Signature: _____

Service 3

Date: _____

Engineer Name: _____

Company Name: _____

Telephone No. _____

Operative ID No. _____

Comments: _____

Signature: _____

Service 4

Date: _____

Engineer Name: _____

Company Name: _____

Telephone No. _____

Operative ID No. _____

Comments: _____

Signature: _____

Service 5

Date: _____

Engineer Name: _____

Company Name: _____

Telephone No. _____

Operative ID No. _____

Comments: _____

Signature: _____

Service 6

Date: _____

Engineer Name: _____

Company Name: _____

Telephone No. _____

Operative ID No. _____

Comments: _____

Signature: _____

Service 7

Date: _____

Engineer Name: _____

Company Name: _____

Telephone No. _____

Operative ID No. _____

Comments: _____

Signature: _____

Service 8

Date: _____

Engineer Name: _____

Company Name: _____

Telephone No. _____

Operative ID No. _____

Comments: _____

Signature: _____

Service 9

Date: _____

Engineer Name: _____

Company Name: _____

Telephone No. _____

Operative ID No. _____

Comments: _____

Signature: _____

Service 10

Date: _____

Engineer Name: _____

Company Name: _____

Telephone No. _____

Operative ID No. _____

Comments: _____

Signature: _____

NIBE Energy Systems Ltd
3C Broom Business Park,
Bridge Way, S41 9QG Chesterfield
Tel: +44 (0)845 095 1200
info@nibe.co.uk
nibe.co.uk

IHB EN 2008-5 331335

This manual is a publication from NIBE Energy Systems. All product illustrations, facts and data are based on the available information at the time of the publication's approval. NIBE Energy Systems makes reservations for any factual or printing errors in this manual.

©2020 NIBE ENERGY SYSTEMS

