

Indoor module NIBE VVM 320

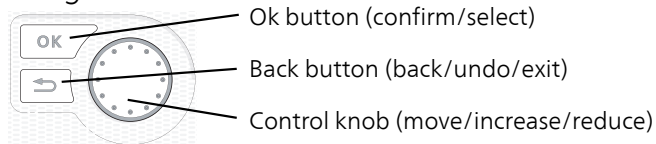

Quick guide

Navigation



A detailed explanation of the button functions can be found on page 40.

How to scroll through menus and make different settings is described on page 42.

Set the indoor climate

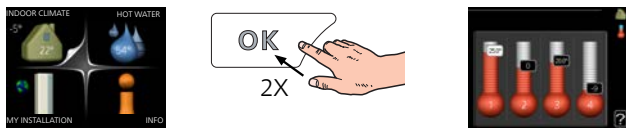

The mode for setting the indoor temperature is accessed by pressing the OK button twice, when in the start mode in the main menu.

Increase hot water volume



To temporarily increase the amount of hot water, first turn the control knob to mark menu 2 (water droplet) and then press the OK button twice.

Table of Contents

1	Important information	4	Setting the heating curve	37
	Safety information	4	Cooling in 2-pipe system	38
	Symbols	4	Setting hot water circulation	38
	Marking	4	Pool	39
	Serial number	5	SG Ready	39
	Recovery	5		
	Inspection of the installation	6	7 Control - Introduction	40
	Outdoor modules	7	Display unit	40
			Menu system	41
2	Delivery and handling	8	8 Control – Menus	44
	Transport	8	Menu 1 - INDOOR CLIMATE	44
	Assembly	8	Menu 2 - HOT WATER	45
	Supplied components	9	Menu 3 - INFO	45
	Removing the covers	10	Menu 4 - MY SYSTEM	46
			Menu 5 - SERVICE	47
3	Indoor module's design	12	9 Service	57
	Component location, rear	13	Service actions	57
	List of components	13	10 Disturbances in comfort	61
			Info-menu	61
4	Pipe connections	14	Manage alarm	61
	General pipe connections	14	Troubleshooting	61
	Dimensions and pipe connections	17	Electrical addition only	63
	Connecting air/water heat pump	18	11 Accessories	64
	Connection during use without heat pump	18	12 Technical data	66
	Heating medium side	18	Dimensions and setting-out coordinates	66
	Cold and hot water	18	Technical specifications	67
	Installation alternative	18	Electrical circuit diagram	70
			Item register	85
5	Electrical connections	20	Contact information	91
	General	20		
	Connections	23		
	Settings	26		
	Optional connections	28		
	Connecting accessories	32		
6	Commissioning and adjusting	34		
	Preparations	34		
	Filling and venting	34		
	Start-up and inspection	35		

1 Important information

Safety information

This manual describes installation and service procedures for implementation by specialists.

The manual must be left with the customer.

This appliance can be used by children aged from 8 years and above and persons with reduced physical, sensory or mental capabilities or lack of experience and knowledge if they have been given supervision or instruction concerning use of the appliance in a safe way and understand the hazards involved. Children shall not play with the appliance. Cleaning and user maintenance shall not be made by children without supervision.

Rights to make any design or technical modifications are reserved.

©NIBE 2020.

<i>System pressure</i>	<i>Max</i>	<i>Min</i>
Heating medium	0.3 MPa (3 bar)	0.05 MPa (0.5 bar)
Domestic water	1.0 MPa (10 bar)	0.01 MPa (0.1 bar)

Water may drip from the safety valve. A factory-fitted overflow pipe goes from the safety valve to an overflow cup. The overflow pipe is visible, its mouth is open and is not located close to electrical components. An overflow pipe should be routed from the overflow cup to a suitable drain. The entire length of this overflow pipe is inclined to prevent water pockets, and it must also be frost-proof.

VVM 320 must be installed via an isolator switch. The cable area has to be dimensioned based on the fuse rating used.

Symbols



NOTE

This symbol indicates danger to person or machine .



Caution

This symbol indicates important information about what you should consider when installing or servicing the installation.



TIP

This symbol indicates tips on how to facilitate using the product.

Marking

CE The CE mark is obligatory for most products sold in the EU, regardless of where they are made.

IP21 Classification of enclosure of electro-technical equipment.



Danger to person or machine.



Read the User Manual.

Serial number

The serial number can be found at the bottom right of the front cover, in the info menu (menu 3.1) and on the type plate (PZ1).

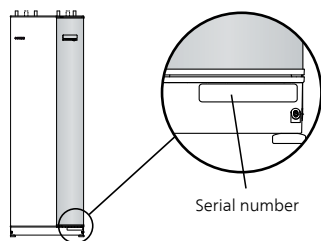

Caution

You need the product's ((14 digit) serial number for servicing and support.

Recovery



Leave the disposal of the packaging to the installer who installed the product or to special waste stations.

Do not dispose of used products with normal household waste. It must be disposed of at a special waste station or dealer who provides this type of service.

Improper disposal of the product by the user results in administrative penalties in accordance with current legislation.

Inspection of the installation

Current regulations require the heating installation to be inspected before it is commissioned. The inspection must be carried out by a suitably qualified person.

In addition, fill in the page for the installation data in the User Manual.

✓	Description	Notes	Signature	Date
	Heating medium, see section "System diagram"			
	System flushed			
	System vented			
	Expansion vessel			
	Particle filter			
	Safety valve			
	Shut off valves			
	Boiler pressure			
	Connected according to outline diagram			
	Hot water, see section "Cold and hot water"			
	Shut off valves			
	Mixing valve			
	Safety valve			
	Electricity, see section "Electrical connections"			
	Connected communication			
	Circuit fuses			
	Fuses, indoor module			
	Fuses property			
	Outside sensor			
	Room sensor			
	Current sensor			
	Safety breaker			
	Earth circuit-breaker			
	Setting of emergency mode thermostat			
	Miscellaneous			
	Docked to			

Outdoor modules

COMPATIBLE AIR/WATER HEAT PUMPS

NIBE SPLIT HBS 05

AMS 10-6

Part no. 064 205

HBS 05-6

Part no. 067 578

AMS 10-8

Part no. 064 033

HBS 05-12

Part no. 067 480

AMS 10-12

Part no. 064 110

HBS 05-12

Part no. 067 480

F2040

F2040-6

Part no. 064 206

F2040-8

Part no. 064 109

F2040-12

Part no. 064 092

F2120

F2120-8 1x230V

Part no. 064 134

F2120-8 3x400V

Part no. 064 135

F2120-12 1x230V

Part no. 064 136

F2120-12 3x400V

Part no. 064 137

F2120-16 3x400V

Part no. 064 139

2 Delivery and handling

Transport

VVM 320 should be transported and stored vertically in a dry place. However, the VVM 320 may be carefully laid on its back when being moved into a building.

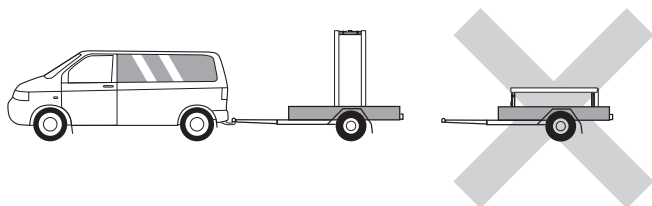

Assembly

- Place VVM 320 on a solid foundation indoors that can take its weight. Use the product's adjustable feet to obtain a horizontal and stable set-up.

The space where VVM 320 is located must be frost-free.

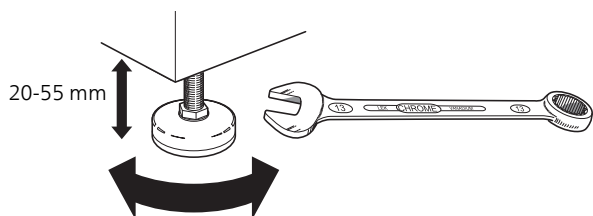

- Because water can emerge from the safety valve, the area where VVM 320 is located must be provided with floor drainage.

INSTALLATION AREA

Leave a free space of 800 mm in front of the product. All service on VVM 320 can be carried out from the front.

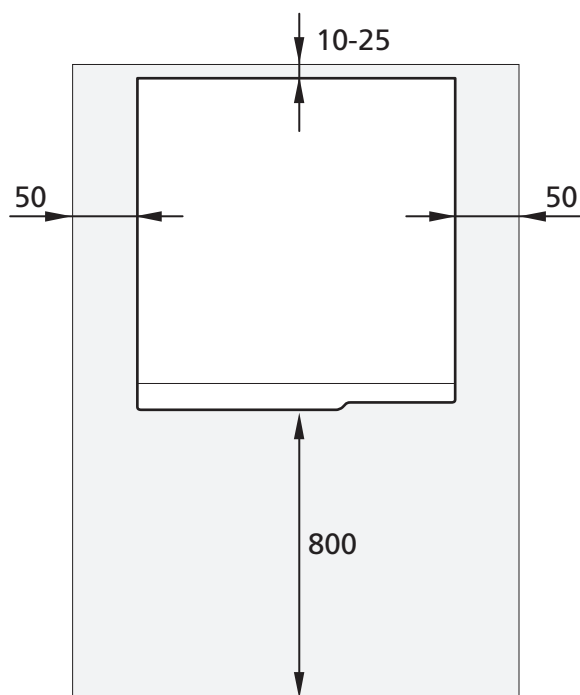

NOTE

Leave 10 – 25 mm free space between VVM 320 and the wall behind for routing cables and pipes.

Supplied components

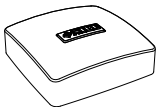

Outside sensor

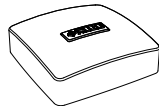

Room sensor

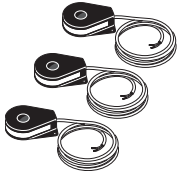

Current sensor*

*Only to 3X400V

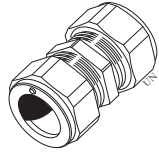

Compression ring coupling*

*Only applies to Germany, Austria, Switzerland and Italy.

LOCATION

The kit of supplied items is placed on top of the product.

Removing the covers

Front cover

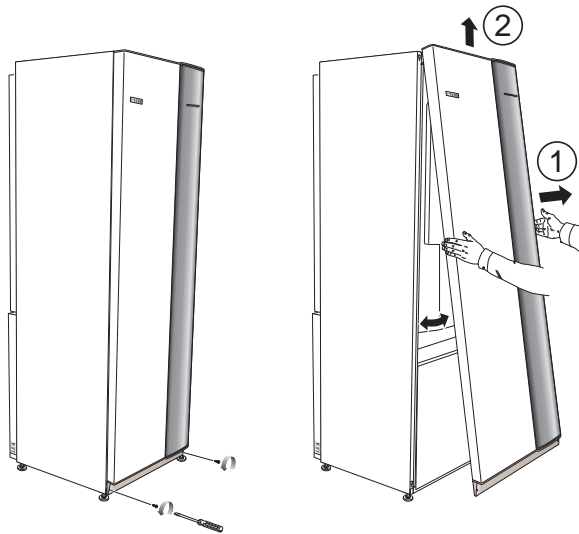

1. Remove the screws from the lower edge of the front panel.
2. Lift the panel out at the bottom edge and up.

Side covers

The side covers can be removed to facilitate the installation.



Caution

50 mm space required to remove the side panels.

1. Remove the screws from the upper and lower edges.
2. Twist the cover slightly outward.
3. Move the hatch backwards and slightly to the side.
4. Pull the cover to one side.
5. Pull the hatch forwards.

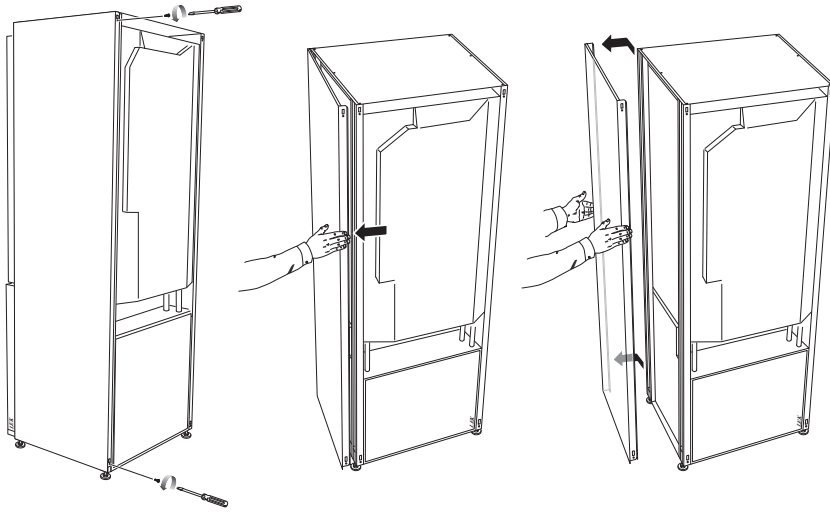

3 Indoor module's design

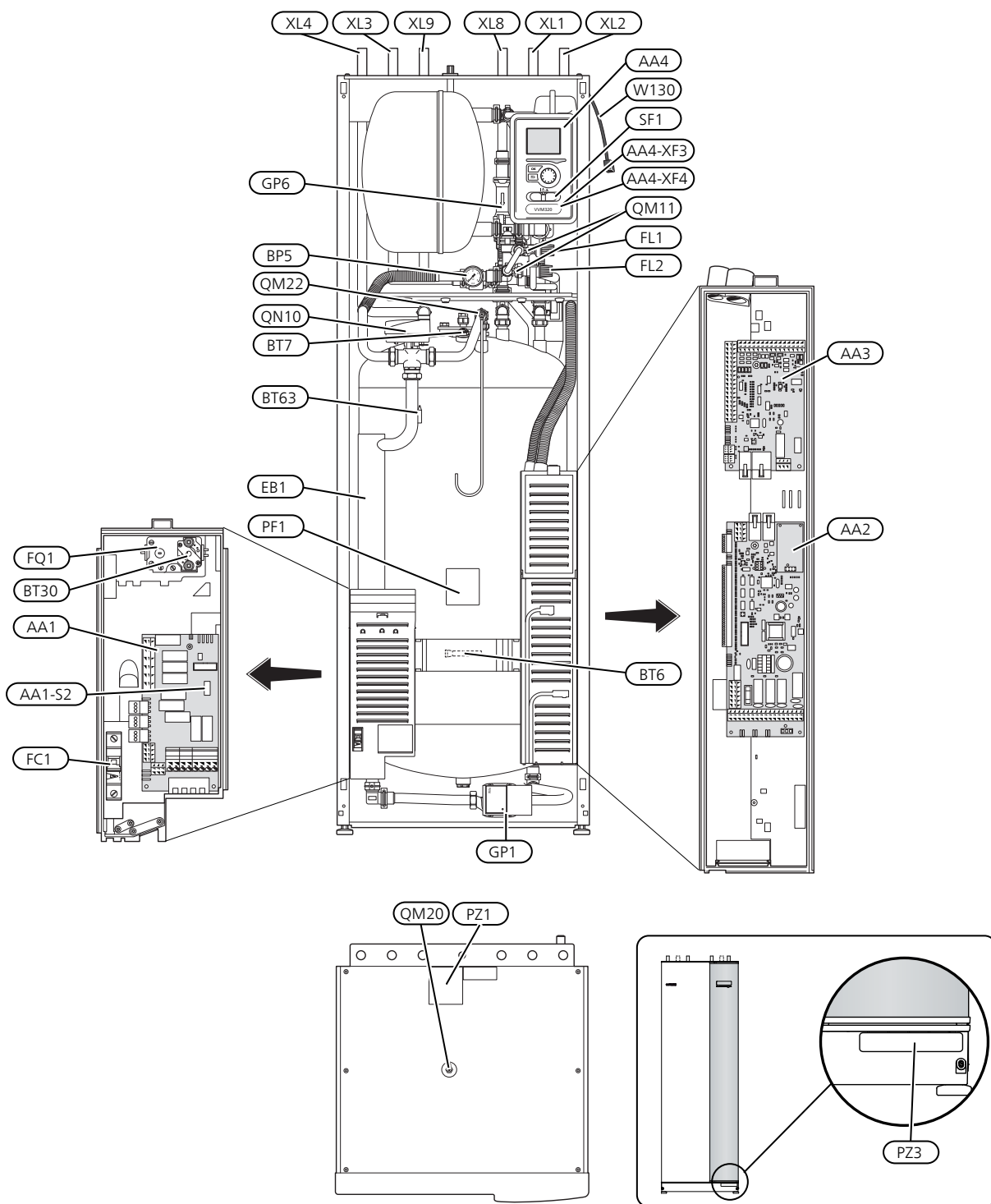

Component location, rear

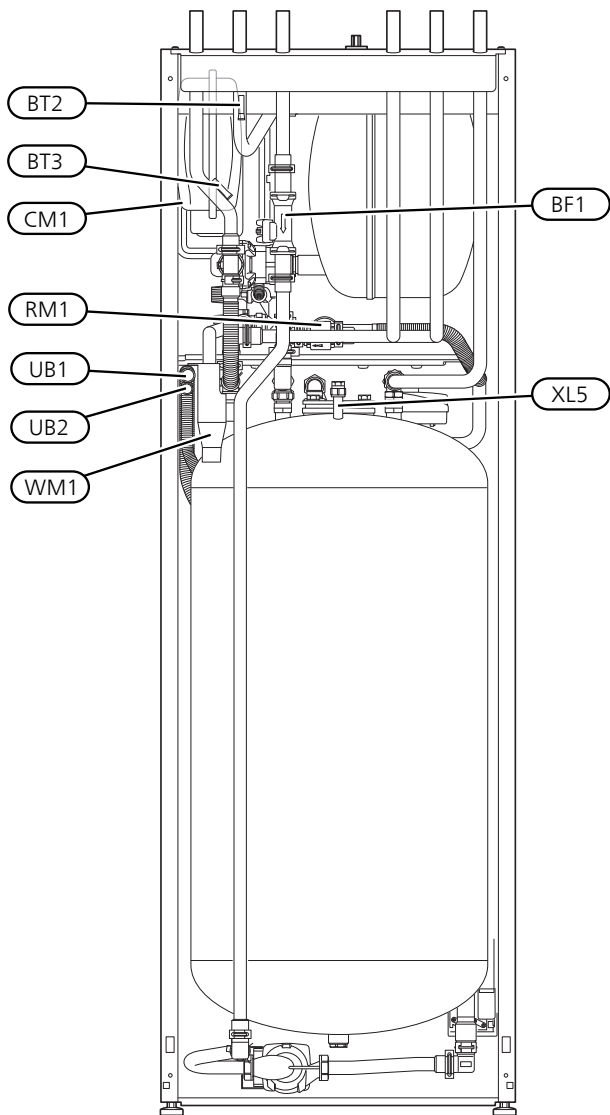

CM1	Expansion vessel, closed, heating medium
FL1	Safety valve, water heater
FL2	Safety valve, heating medium
GP1	Circulation pump
GP6	Circulation pump, heating medium
QM11	Filler valve, heating medium
QM20	Venting, climate system
QM22	Venting valve, coil
QN10	Reversing valve, climate system/water heating, flow line
RM1 ¹⁾	Check valve, cold water
WM1	Tundish

SENSORS ETC.

BP5	Manometer, heating system
BT2	Temperature sensors, heating medium flow
BT3	Temperature sensors, heating medium return
BT6	Temperature sensor, hot water, charging
BT7	Temperature sensor, hot water, top
BT30	Thermostat, standby mode
BT63	Temperature sensor, heating medium supply after immersion heater

ELECTRICAL COMPONENTS

AA1	Immersion heater card AA1-S2 Switch (DIP switch) on circuit board
AA2	Base card
AA3	Input circuit board
AA4	Display unit AA4-XF3 USB socket AA4-XF4 Service socket
BF1 ²⁾	Energy meter
EB1	Immersion heater
FC1	Miniature circuit-breaker
FQ10	Temperature limiter
SF1	Switch
W130	Network cable for NIBE Uplink™

List of components

PIPE CONNECTIONS

XL1	Connection, heating medium supply line Ø22 mm
XL2	Connection, heating medium return line Ø22 mm
XL3	Connection, cold water Ø22 mm
XL4	Connection, hot water Ø22 mm
XL5	Connection, hot water circulation Ø15 mm (does not apply to copper)
XL8	Connection, docking from heat pump Ø22 mm
XL9	Connection, docking to heat pump Ø22 mm

HVAC COMPONENTS

1) Not Denmark.

2) Applies to VVM 320 R, VVM 320 3x230V R and VVM 320 E EM. Available as accessory EMK 300 for other markets.

MISCELLANEOUS

PZ1	Rating plate
PZ3	Serial number plate
UB1	Cable gland
UB2	Cable gland

Designations according to standard EN 81346-2.

4 Pipe connections

General pipe connections

Pipe installation must be carried out in accordance with current norms and directives.

The pipe dimension should not be less than the recommended pipe diameter according to the table. However, each system must be dimensioned individually to manage the recommended system flows.

MINIMUM SYSTEM FLOWS

The installation must be dimensioned at least to manage the minimum defrosting flow at 100% pump operation, see table.

<i>Air/water heat pump</i>	<i>Minimum flow during defrosting (100% pump speed (l/s))</i>	<i>Minimum recommended pipe dimension (DN)</i>	<i>Minimum recommended pipe dimension (mm)</i>
F2120-8 (1x230V)	0.27	20	22
F2120-8	0.27	20	22
F2120-12 (1x230V)	0.35	25	28
F2120-12	0.35	25	28
F2120-16	0.38	25	28

<i>Air/water heat pump</i>	<i>Minimum flow during defrosting (100% pump speed (l/s))</i>	<i>Minimum recommended pipe dimension (DN)</i>	<i>Minimum recommended pipe dimension (mm)</i>
F2040-6	0.19	20	22
F2040-8	0.19	20	22
F2040-12	0.29	20	22

<i>Air/water heat pump</i>	<i>Minimum flow during defrosting (100% pump speed (l/s))</i>	<i>Minimum recommended pipe dimension (DN)</i>	<i>Minimum recommended pipe dimension (mm)</i>
HBS 05-6/AMS 10-6	0.19	20	22
HBS 05-12/AMS 10-8	0.19	20	22
HBS 05-12/AMS 10-12	0.29	20	22



NOTE

An undersized system can result in damage to the machine and lead to malfunctions.

VVM 320 together with a compatible air/water heat pump (See chapter "Outdoor modules") constitutes a complete installation for heating and hot water.

The system requires the size of the radiator circuit to be designed for a low temperature heating medium. At the lowest dimensioned outdoor temperature, the highest recommended temperatures are 55 °C on the supply line and 45 °C on the return line, but VVM 320 can handle up to 70 °C on the supply line.

Overflow water from the safety valve goes via an overflow cup to a drain so that hot water splashes cannot cause injury. The entire length of the overflow water pipe must be inclined to prevent water pockets, and must also be frost-proof. The mouth of the overflow water pipe must be visible and not located close to electrical components.

NIBE recommends installing VVM 320 as close to the heat pump as possible for optimum comfort. For further information about the location of different components, see section "Installation alternatives" in this manual.



Caution

Ensure that incoming water is clean. When using a private well, it may be necessary to supplement with an extra water filter.



NOTE

Any high points in the climate system, must be equipped with air vents.



NOTE

The pipe systems need to be flushed out before the indoor module is connected so that any debris cannot damage component parts.



NOTE

Switch (SF1) must not be moved to "I" or "Δ" until VVM 320 has been filled with water. Otherwise the temperature limiter, thermostat and the immersion heater etc can be damaged.

SYSTEM DIAGRAM

VVM 320 consists of water heater with charge coil, expansion vessel, safety valve, filler valve, immersion heater, circulation pumps, buffer vessel and control system. VVM 320 is connected to the climate system.

VVM 320 is directly adapted for connection and communication with a compatible NIBE air/water heat pump, see section "Outdoor modules", and together they constitute a complete heating installation.

When it is cold outdoors, the air/water heat pump works with VVM 320, and if the outdoor air temperature falls below the heat pump's stop temperature, all heating is carried out by VVM 320.

BOILER AND RADIATOR VOLUMES

VVM 320 is equipped with a pressure expansion vessel of 10 litres.

The pre-pressure of the pressure expansion vessel must be dimensioned according to the maximum height (H) between the vessel and the highest positioned radiator, see figure. A pre-pressure of 0.5 bar (5 mvp) means a maximum permitted height difference of 5 m.

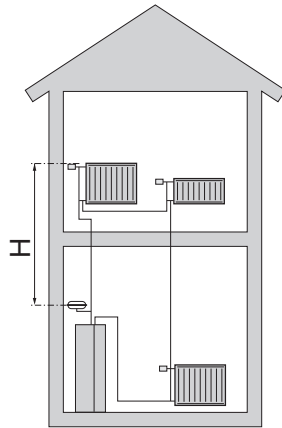







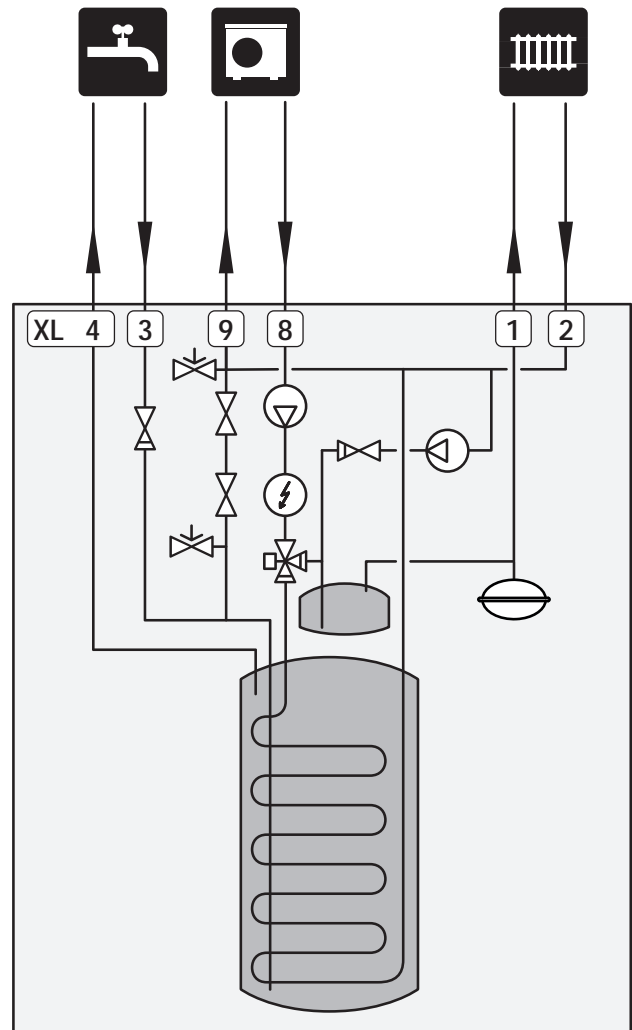













The maximum system volume excluding the boiler is 220 litres at the above pre-pressure.

Volume expansion

Approx. 10 l/kW is required for connection to the heat pump, and many heating systems do not have this volume. To prevent operational problems, the volume is then expanded using a UKV buffer vessel.



SYMBOL KEY

<i>Symbol</i>	<i>Meaning</i>
	Shut-off valve
	Non-return valve
	Mixing valve
	Circulation pump
	Immersion heater
	Expansion vessel
	Filterball
	Flow meter/energy meter
	Shut off valve
	Pressure gauge
	Control valve
	Safety valve
	Reversing valve/shunt
	Manual reversing valve/shunt
	Under floor heating systems
	Indoor module
	Cooling system
	Air/water heat pump
	Radiator system
	Domestic hot water
	Hot water circulation

Dimensions and pipe connections

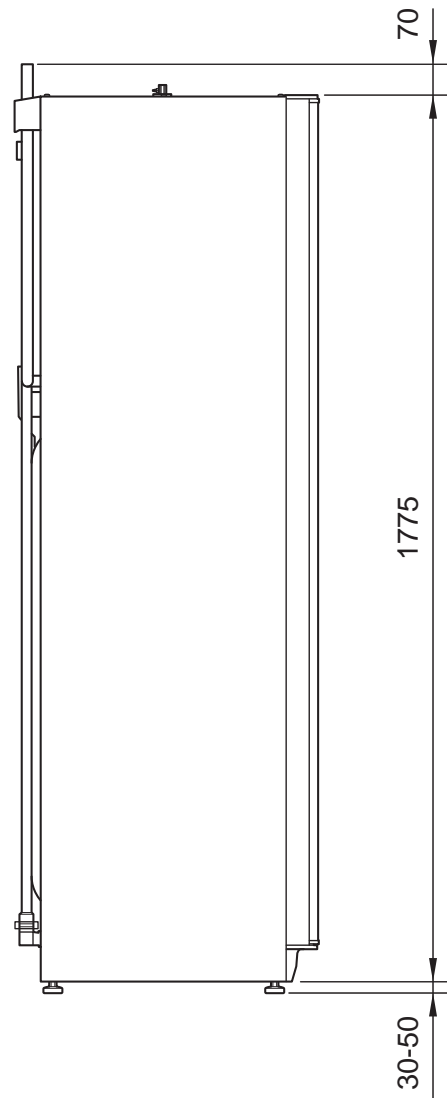
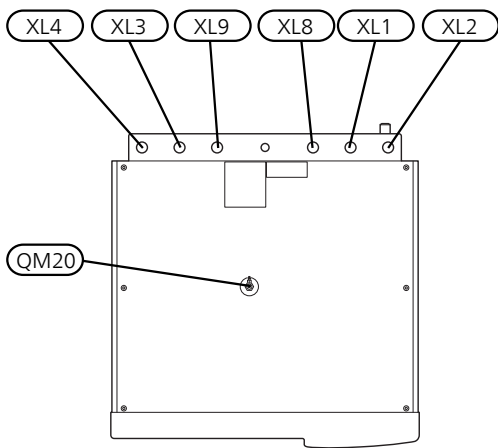
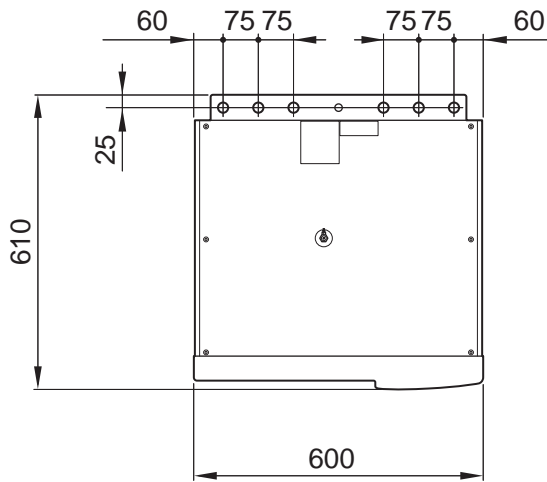

PIPE CONNECTIONS

- XL1 Connection, heating medium supply line Ø22 mm
- XL2 Connection, heating medium return line Ø22 mm
- XL3 Connection, cold water Ø22 mm
- XL4 Connection, hot water Ø22 mm
- XL5 Connection, hot water circulation Ø15 mm (does not apply to copper)
- XL8 Connection, docking from heat pump Ø22 mm
- XL9 Connection, docking to heat pump Ø22 mm

Connecting air/water heat pump

You can find a list of compatible air/water heat pumps in section "Outdoor modules".

VVM 320 is not equipped with shut off valves; these must be installed outside the indoor module to facilitate any future servicing.

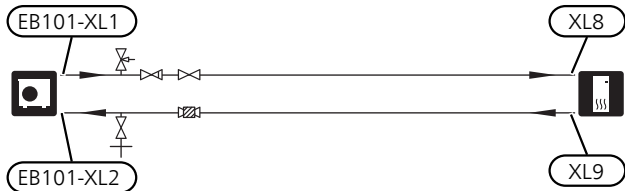

Connection during use without heat pump

Connect the pipe for docking in from the heat pump (XL8) with the pipe out to the heat pump XL9.

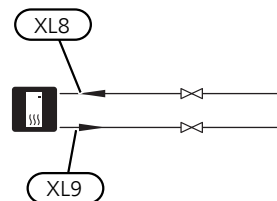

Heating medium side

CONNECTING THE CLIMATE SYSTEM

A climate system is a system that regulates indoor comfort with the help of the control system in VVM 320 and for example radiators, underfloor heating/cooling, fan convectors etc.

- When connecting to a system with thermostats on all radiators (or underfloor heating coils), either a bypass valve must be fitted or some of the thermostats must be removed to ensure there is sufficient flow.



Cold and hot water

The settings for hot water are made in menu 5.1.1.

CONNECTING COLD AND HOT WATER

Install as follows:

- shut-off valve

- mixing valve

A mixer valve must also be installed, if the factory setting for hot water is changed. National regulations must be observed.

- non-return valve¹

¹ Only VVM 320 for Denmark

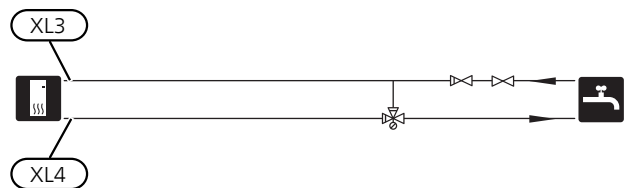

Installation alternative

VVM 320 can be installed in several different ways, some of which are shown below.

Further option information is available at nibe.eu and in the respective assembly instructions for the accessories used. See page 64 for a list of the accessories that can be used with VVM 320.

EXTRA HOT WATER HEATERS

The system can be supplemented with an extra water heater, if a large bath tub or other significant consumer of hot water is installed. A mixer valve is then installed on the outgoing hot water from the water heater.

Water heater with immersion heater

If it is possible to use a water heater with an immersion heater, connect it as illustrated below.

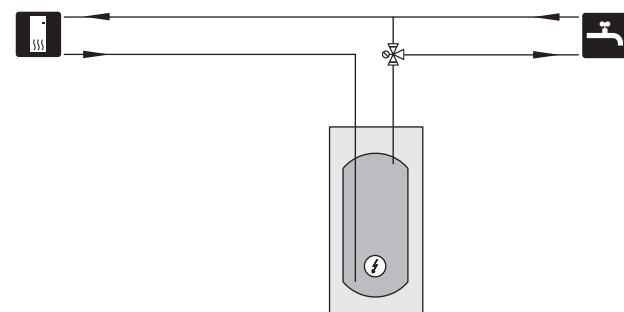

EXTRA CLIMATE SYSTEM

In buildings with several climate systems that require different supply temperatures, the accessory ECS 40/ECS 41 can be connected.

A shunt valve then lowers the temperature to the under-floor heating system, for example.

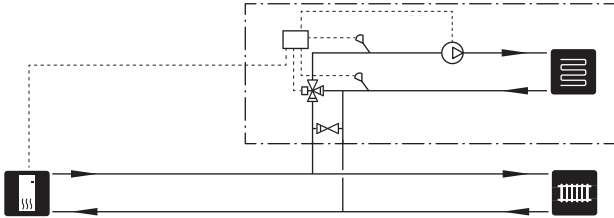

CONNECTING HOT WATER CIRCULATION

A circulation pump can be controlled by VVM 320 to circulate the hot water. The circulating water must have a temperature that prevents bacterial growth and scalding, and national standards must be satisfied.

The HWC return can be connected to XL5 or a freestanding water heater. If an electric water heater is connected after the heat pump, the HWC return must be connected to the water heater.

The circulation pump is activated via AUX input in menu 5.4.

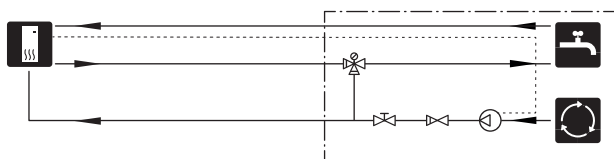

5 Electrical connections

General

All electrical equipment, except the outdoor sensors, room sensors and the current sensors are ready connected at the factory.

- Disconnect the indoor module before insulation testing the house wiring.
- If the building is equipped with an earth-fault breaker, VVM 320 should be equipped with a separate one.
- For the indoor module electrical wiring diagram, see section "Electrical circuit diagram".
- Communication and sensor cables to external connections must not be laid close to high current cables.
- The minimum area of communication and sensor cables to external connections must be 0.5 mm² up to 50, for example EKKX or LiYY or equivalent.
- When cable routing in VVM 320, cable grommets UB1 and UB2, (marked in image) must be used. In UB1 and UB2, the cables are inserted through the indoor module from the back to the front.

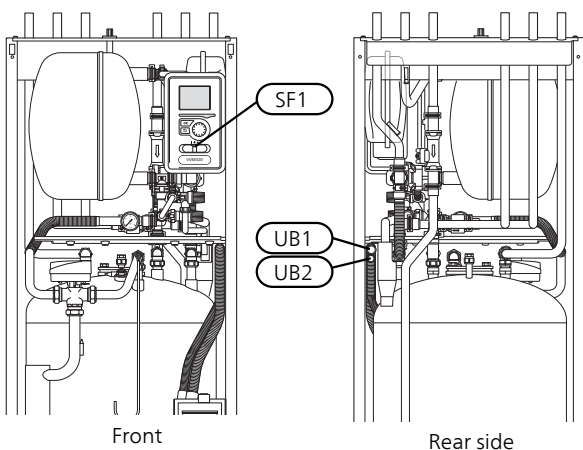

NOTE

The switch (SF1) must not be set to "I" or "Δ" until the boiler has been filled with water and the radiator system vented. Otherwise the temperature limiter, thermostat and the immersion heater can be damaged.



NOTE

If the supply cable is damaged, only NIBE, its service representative or similar authorised person may replace it to prevent any danger and damage.



NOTE

Electrical installation and service must be carried out under the supervision of a qualified electrician. Cut the current with the circuit breaker before carrying out any servicing. Electrical installation and wiring must be carried out in accordance with the stipulations in force.

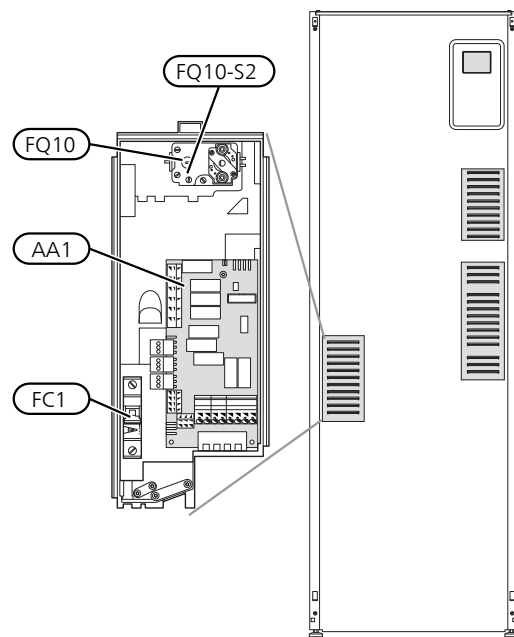

MINIATURE CIRCUIT-BREAKER

The indoor module and a large proportion of its internal components are internally fused by a miniature circuit breaker (FC1).

TEMPERATURE LIMITER

The temperature limiter (FQ10) cuts the power supply to the electric additional heat, if the temperature rises to between 90 and 100 °C and it is reset manually.

Resetting

The temperature limiter (FQ10) is accessible behind the front cover. Reset the temperature limiter by pressing the button (FQ10-S2) using a small screwdriver. Press the button lightly, max. 15 N (approx. 1.5 kg).

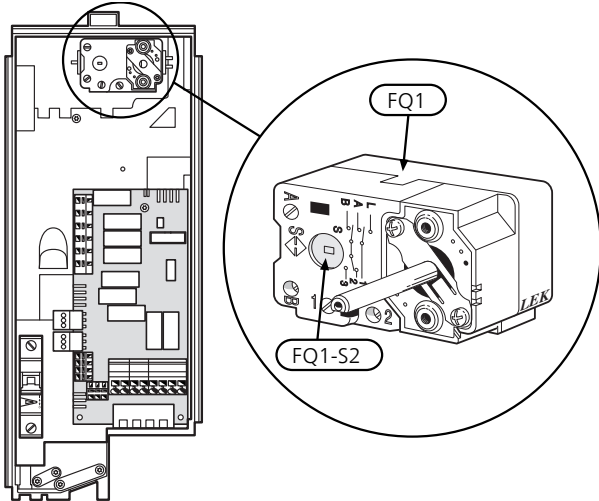

ACCESSIBILITY, ELECTRICAL CONNECTION

The plastic cap of the electrical boxes is opened using a screwdriver.



NOTE

The cover for the input card is opened without a tool.

Removing the cover, input circuit board

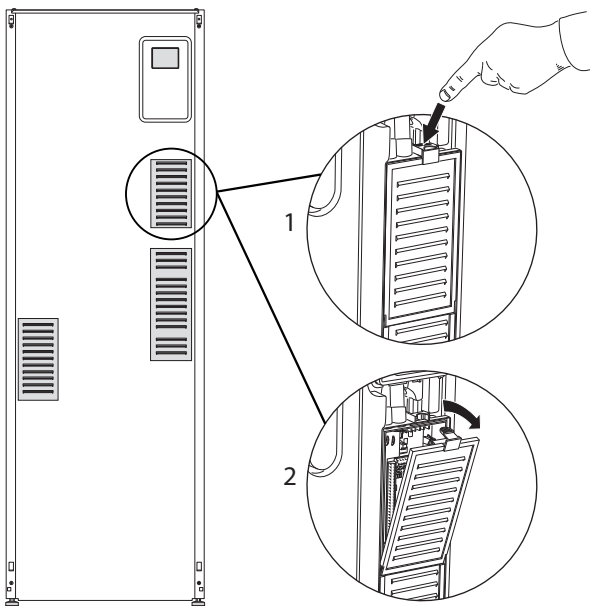

1. Push the catch down.
2. Angle out the cover and remove it.

Removing the cover, immersion heater circuit board

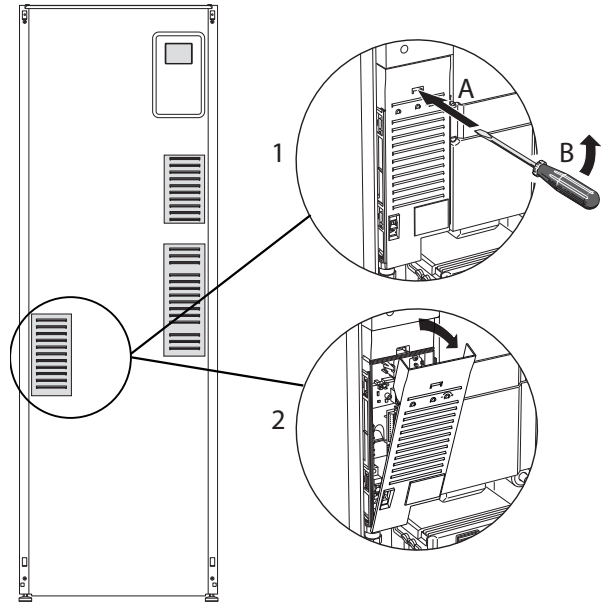

1. Insert the screwdriver (A) and pry the catch carefully downwards (B).
2. Angle out the cover and remove it.

Removing the cover, base board



Caution

To remove the cover for the base board, the cover for the input circuit board must first be removed.

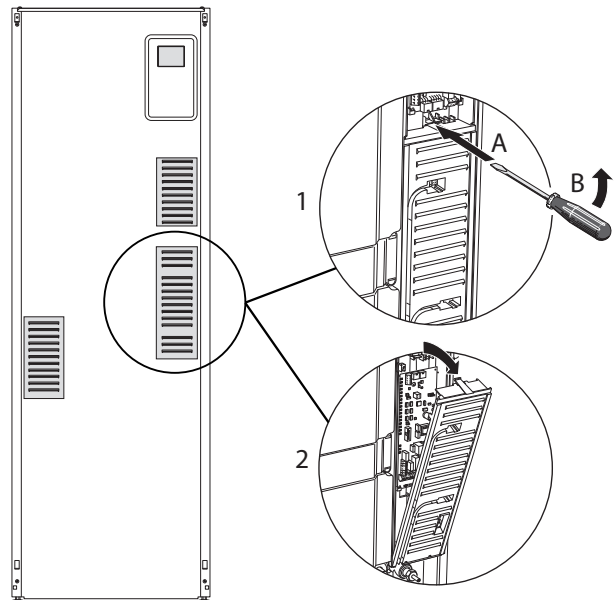

1. Insert the screwdriver (A) and pry the catch carefully downwards (B).
2. Angle out the cover and remove it.

CABLE LOCK

Use a suitable tool to release/lock cables in the indoor module terminal blocks.

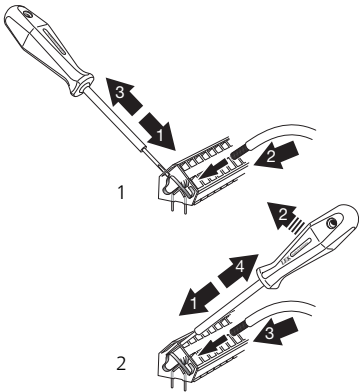

Connections



NOTE

To prevent interference, unscreened communication and/or sensor cables to external connections must not be laid closer than 20 cm from high voltage cables.

POWER CONNECTION

VVM 320 must be installed with a disconnection option on the supply cable. Minimum cable area must be sized according to the fuse rating used. The enclosed cable (length approx. 2 m) for incoming electricity is connected to terminal block X1 on the immersion heater board (AA1). All installations must be carried out in accordance with current norms and directives. The connection cable can be found on the reverse of VVM 320.

Connection

3x400V

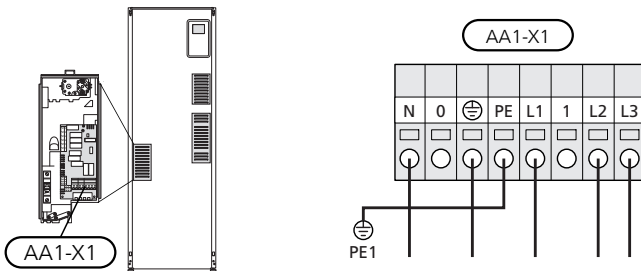

3x230V

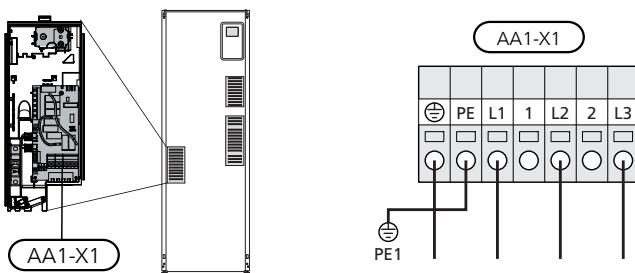

1x230V

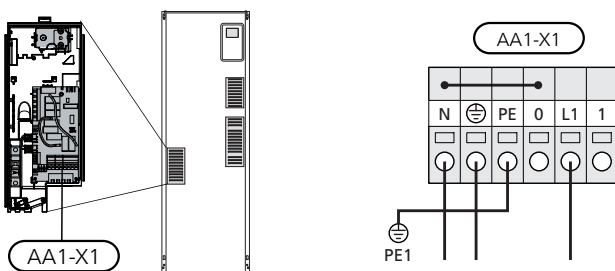

TARIFF CONTROL

If the voltage to the immersion heater disappears during a certain period, there must also be blocking via the AU-input, see "Connection options- Possible selection for AU inputs".

TEMPERATURE SENSOR, EXTERNAL FLOW LINE

If temperature sensor, external flow line (BT25) needs to be used, connect it to terminal block X6:5 and X6:6 on the input card (AA3). Use a 2 core cable of at least 0.5 mm² cable area.

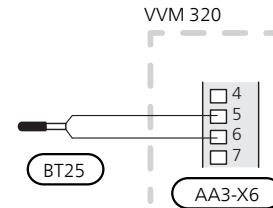

CONNECTING EXTERNAL OPERATING VOLTAGE FOR THE CONTROL SYSTEM



NOTE

Only applies to power connection of 3x400V.



NOTE

Mark up any junction boxes with warnings for external voltage.

If you wish to connect external operating voltage for the control system to VVM 320 on the immersion heater circuit board (AA1) the edge connector at AA1:X2 must be moved to AA1:X9 (as illustrated).

Operating voltage (1x230V ~ 50Hz) is connected to AA1:X11 (as illustrated).

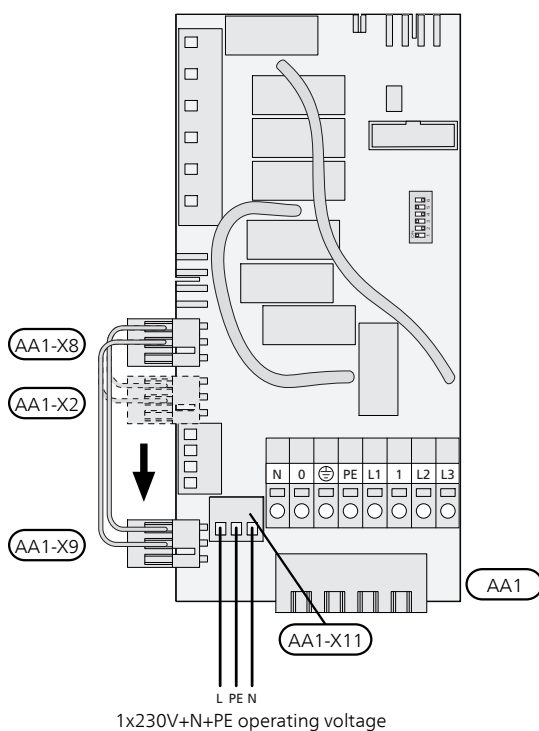

CONNECTING SENSOR

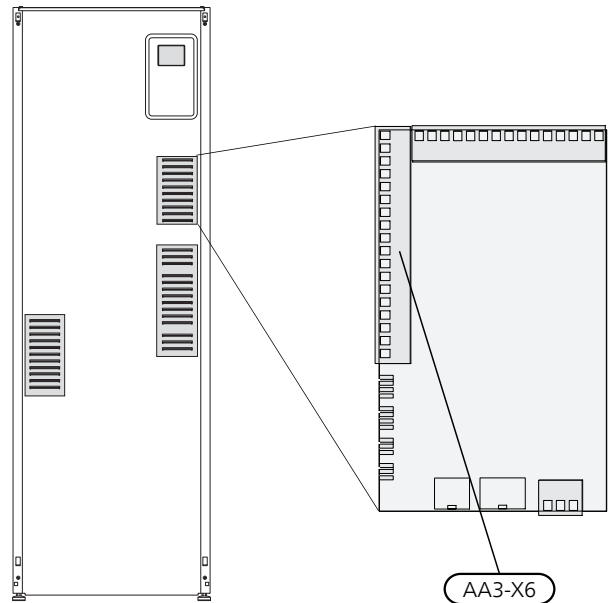

Outside sensor

Install the outdoor temperature sensor (BT1) in the shade on a wall facing north or north-west, so it is unaffected by the morning sun for example.

Connect the sensor to terminal block X6:1 and X6:2 on the input board (AA3).

If a conduit is used it must be sealed to prevent condensation in the sensor capsule.

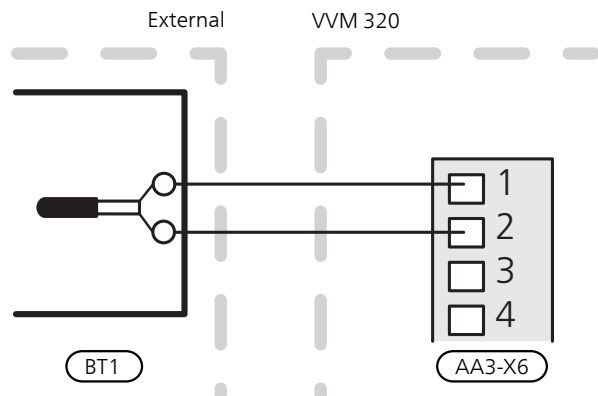

Room sensor

VVM 320 is supplied with a room sensor enclosed (BT50). The room sensor has a number of functions:

1. Shows current room temperature in the display on VVM 320.
2. Option of changing the room temperature in °C.
3. Provides the option of fine-tuning the room temperature.

Install the sensor in a neutral position where the set temperature is required. A suitable location is on a free inner wall in a hall approx. 1.5 m above the floor. It is important that the sensor is not obstructed from measuring the correct room temperature by being located, for example, in a recess, between shelves, behind a curtain, above or close to a heat source, in a draft from an external door or in direct sunlight. Closed radiator thermostats can also cause problems.

The indoor module operates without the sensor, but if one wishes to read off the accommodation's indoor temperature in VVM 320's display, the sensor must be installed. Connect the room sensor to X6:3 and X6:4 on the input board (AA3).

If the sensor is to have a controlling function, it is activated in menu 1.9.4.

If the room sensor is used in a room with underfloor heating, it should only have an indicative function, not control of the room temperature.

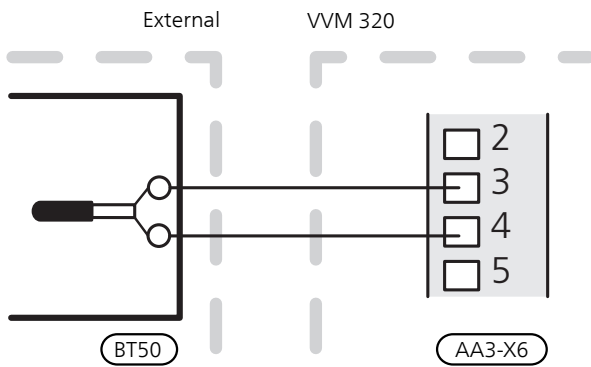

Caution

Changes of temperature in accommodation take time. For example, short time periods in combination with underfloor heating will not give a noticeable difference in room temperature.

COMMUNICATION

If VVM 320 is to be connected to the heat pump, it is connected to terminal blocks X4:13, X4:14 and X4:15 on the input board (AA3).

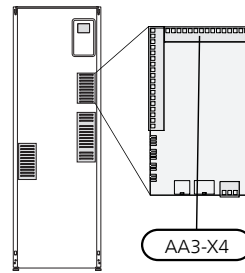

VVM 320 and F2040 / NIBE SPLIT HBS 05

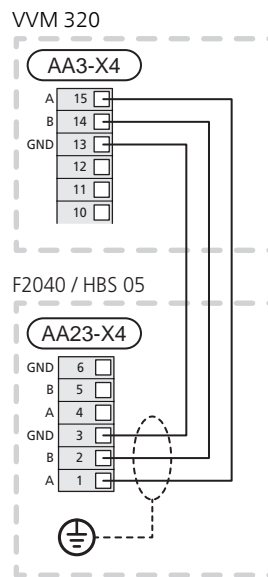

VVM 320 and F2120

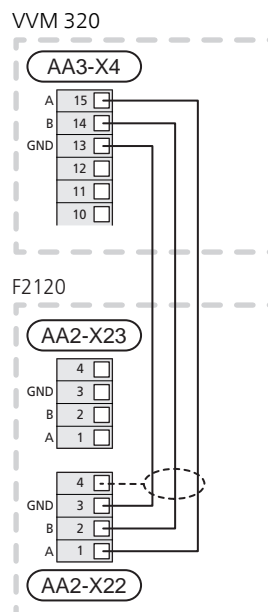

Settings

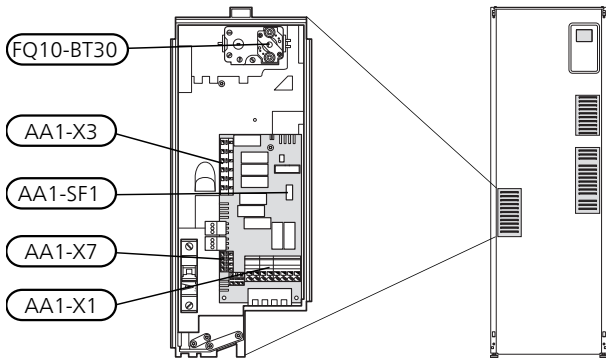

ELECTRICAL ADDITION - MAXIMUM OUTPUT

The immersion heater output is divided into 7 steps, according to the table.

The immersion heater can be set to a maximum of 9 kW (3-phase) or 7 kW (1-phase). The settings on delivery are 9 kW (3-phase) or 7 kW (1-phase).

You reconnect to 7 kW by transferring the white cable from terminal block X3:13 to terminal block X7:23 on the electric addition PCB (AA1) (Only applies to 3x400V). (The seal on the terminal block must be broken.)

Setting maximum output in the electric additional heat is done in menu 5.1.12.

Power steps of the immersion heater

3x400V (maximum electrical output, connected upon delivery 9 kW)

Electrical addition (kW)	Max L1 (A)	Max L2 (A)	Max L3 (A)
0	0.0	0.0	0.0
2	0.0	8.7	0.0
3	0.0	7.5	7.5
4	0.0	8.7	8.7
5	8.7	7.5	7.5
6	8.7	8.7	8.7
7	8.7	7.5	16.2
9	8.7	16.2	16.2

3x400V (maximum electrical output, connected to 7 kW)

Electrical addition (kW)	Max L1 (A)	Max L2 (A)	Max L3 (A)
0	0.0	0.0	0.0
1	0.0	0.0	4.3
2	0.0	8.7	0.0
3	0.0	8.7	4.3
4	0.0	8.7	8.7
5	8.7	0.0	13
6	8.7	8.7	8.7
7	8.7	8.7	13

3x230V (maximum electrical output, connected upon delivery 9 kW)

Electrical addition (kW)	Max (A) L1	Max (A) L2	Max (A) L3
0	0.0	0.0	0.0
2	0.0	8.7	8.7
4	8.7	15.1	15.1
6	15.1	15.1	15.1
9	15.1	27.1	27.1

1x230V (maximum electrical output, connected upon delivery 7 kW)

Electrical addition (kW)	Max L1 (A)
0	0.0
1	4.3
2	8.7
3	13
4	17.4
5	21.7
6	26.1
7	30.4

The tables display the maximum phase current for the relevant electrical step for the indoor module.

If the current sensors are connected, the indoor module monitors the phase currents.



NOTE

If the current sensors are not connected, the indoor module performs a calculation of how high the currents will be if the relevant power steps are added. If the currents are higher than the set fuse size, the power step is not allowed to cut in. See chapter Load monitor on page 28.

EMERGENCY MODE

When the indoor module is set to emergency mode (SF1 is set to Δ) only the most necessary functions are activated.

- No hot water is produced.
- The load monitor is not connected.
- Fixed temperature in the supply line, see section Emergency mode thermostat.

Power in emergency mode

The immersion heater's output in emergency mode is set with the DIP switch (SF1) on the immersion heater board (AA1), according to the table below. The factory setting is 6 kW.

Power in emergency mode, 3x400V (maximum electrical output, connected to 7 kW)

kW	1	2	3	4	5	6
0	off	off	off	off	off	off
1	off	off	off	off	off	on
2	off	off	on	off	off	off
3	off	off	on	off	off	on
4	off	off	on	off	on	off
5	on	off	off	off	on	on
6	on	off	on	off	on	off
7	on	off	on	off	on	on

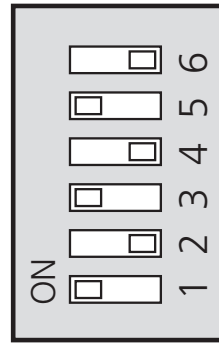

The image shows the dip-switch (AA1-SF1) in the factory setting for 3x400V, that is 6 kW.

Power in emergency mode, 3x400V (maximum electrical output, connected upon delivery 9 kW)

kW	1	2	3	4	5	6
0	off	off	off	off	off	off
2	off	off	on	off	off	off
3	off	off	off	on	off	on
4	off	off	on	off	on	off
5	on	off	off	on	off	on
6	on	off	on	off	on	off
7	on	off	off	on	on	on
9	on	off	on	on	on	on

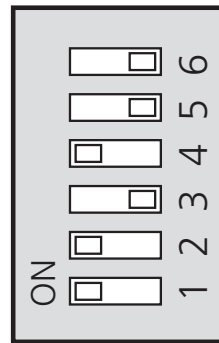

The image shows the dip-switch (AA1-SF1) in the factory setting for 3x230V, that is 6 kW.

Power in emergency mode, 3x230V (maximum electrical output, connected upon delivery 9 kW)

kW	1	2	3	4	5	6
0	off	off	off	off	off	off
2	off	on	off	off	off	off
4	off	on	off	on	off	off
6	on	on	off	on	off	off
9	on	on	on	on	off	off

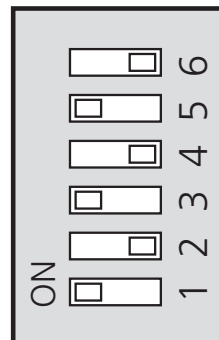

The image shows the dip-switch (AA1-SF1) in the factory setting for 1x230V, that is 6 kW.

Power in emergency mode, 1x230V (maximum electrical output, connected upon delivery 7 kW)

kW	1	2	3	4	5	6
0	off	off	off	off	off	off
1	off	off	off	off	off	on
2	off	off	on	off	off	off
3	off	off	on	off	off	on
4	on	off	on	off	off	off
5	on	off	on	off	off	on
6	on	off	on	off	on	off
7	on	off	on	off	on	on

Emergency mode thermostat

The supply temperature in emergency mode is set using a thermostat (FQ10-BT30). It can be set to 35 (preset, e.g. underfloor heating) or 45 °C (e.g. radiators).

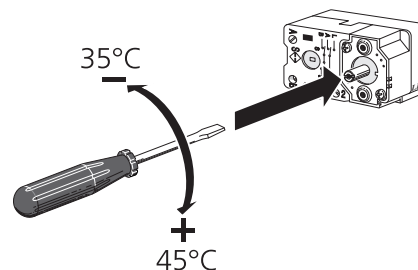

Optional connections

LOAD MONITOR

Integrated load monitor

VVM 320 is equipped with a simple form of integrated load monitor, which limits the power steps for the electric additional heat by calculating whether future power steps can be connected to the relevant phase without exceeding the specified main fuse. If the current would exceed the specified main fuse, the power step is not permitted. The size of the property's main fuse is specified in menu 5.1.12.

Load monitor with current sensor

When many power-consuming products are connected in the property at the same time as the electric additional heat is operating, there is a risk that the property's main fuse will trip. VVM 320 is equipped with a load monitor that, with the help of a current sensor, controls the power steps for the electric additional heat by redistributing the power between the different phases or disengages the electric additional heat if there is an overload in a phase. Reconnection occurs when the other current consumption drops.

Caution
 Activate phase detection in menu 5.1.12 for full functionality, if current sensors are installed.

Connecting current sensors

NOTE
 If the installed air/water heat pump is frequency controlled, it will be limited when all power stages are disconnected.

A current sensor should be installed on each incoming phase conductor into the distribution box to measure the current. The distribution box is an appropriate installation point.

Connect the current sensors to a multi-core cable in an enclosure directly adjacent to the electrical distribution unit. The multi-core cable between the enclosure and VVM 320 must have a cable area of at least 0.5 mm².

Connect the cable to the input board (AA3) on terminal block X4:1-4 where X4:1 is the common terminal block for the three current sensors.

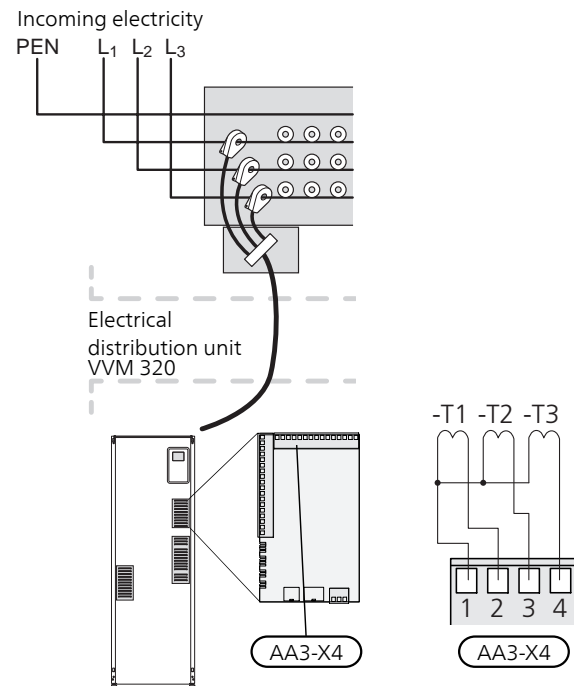

If the installed heat pump is frequency controlled, it will be limited when all power stages are disengaged.

NIBE UPLINK

Connect the network connected cable (straight, Cat.5e UTP) with RJ45-contact (male) to RJ45 contact (female) on the rear of the indoor unit.

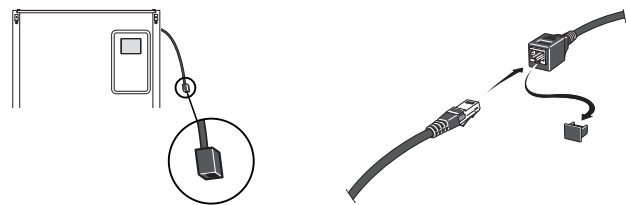

EXTERNAL CONNECTION OPTIONS (AUX)

VVM 320 has software-controlled AUX inputs and outputs for connecting the external switch function (contact has to be potential-free) or sensor.

Go into menu 5.4 "soft in/outputs" on the display to select to which AUX connection each function connects.

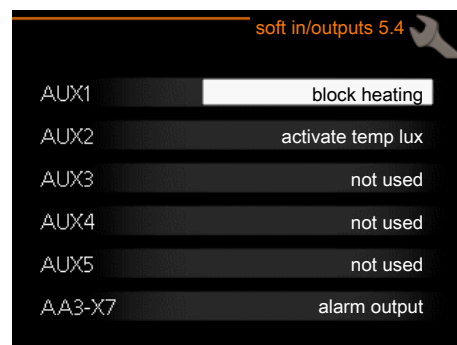

For certain functions, accessories may be required.



TIP

Some of the following functions can also be activated and scheduled via menu settings.

Selectable inputs

Selectable inputs on the input board (AA3) for these functions are:

AUX1	AA3-X6:9-10
AUX2	AA3-X6:11-12
AUX3	AA3-X6:13-14
AUX4	AA3-X6:15-16
AUX5	AA3-X6:17-18

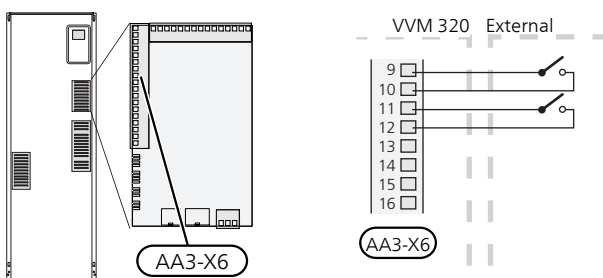

The example above uses the inputs AUX1 (X6:9-10) and AUX2 (X6:11-12) on the input board (AA3).

Selectable output

A selectable output is AA3-X7.

The output is a potential-free switching relay.

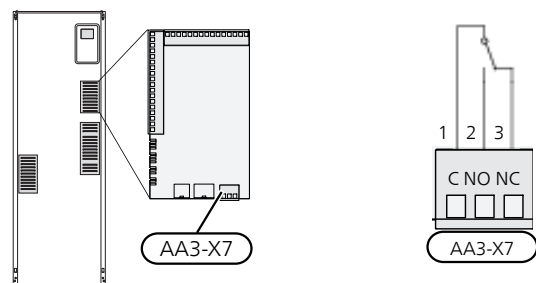

The picture shows the relay in the alarm position.

When switch (SF1) is in the "U" or "Δ" position the relay is in the alarm position.



Caution

The relay outputs may be subjected to a max load of 2 A at resistive load (230V AC).



TIP

The AXC accessory is required if more than one function is to be connected to the AUX output.

Possible selection for AUX inputs

Temperature sensor

Temperature sensor can be connected to VVM 320.

Available options are:

- cooling/heating/hot water, determines when it is time to switch between cooling, heating and hot water mode (selectable when the air/water heat pump is permitted to produce cooling).
- supply temperature sensor for cooling (BT64) (used when "active cooling in 4-pipe system" has been activated in the output AA3-X7)

Monitor

Available options are:

- alarm from external units. The alarm is connected to the control, which means that the malfunction is presented as an information message in the display. Potential-free signal of type NO or NC.
- stove monitor. (A thermostat that is connected to the chimney. When the negative pressure is too low and the thermostat is connected, the fans in ERS (NC) are switched off.
- pressure switch for climate system (NC).

External activation of functions

An external switch function can be connected to VVM 320 to activate various functions. The function is activated during the time the switch is closed.

Possible functions that can be activated:

- hot water comfort mode "temporary lux"
- hot water comfort mode "economy"
- "external adjustment"

When the switch is closed, the temperature changes in °C (if the room sensor is connected and activated). If a room sensor is not connected or not activated, the desired change of "temperature" (heating curve offset) is set with the number of steps selected. The value is adjustable between -10 and +10. External adjustment of climate systems 2 to 8 requires accessories.

– climate system 1 to 8

The value for the change is set in menu 1.9.2, "external adjustment".

- SG ready



Caution

This function can only be used in mains networks that support the "SG Ready" standard. "SG Ready" requires two AUX inputs.

"SG Ready" is a smart form of tariff control, through which your electricity supplier can affect the indoor, hot water and/or pool temperatures (if applicable) or simply block the additional heat and/or compressor in the heat pump at certain times of the day (can be se-

lected in menu 4.1.5 after the function is activated). Activate the function by connecting potential-free switch functions to two inputs selected in menu 5.4 (SG Ready A and SG Ready B).

Closed or open switch means one of the following:

– *Blocking (A: Closed, B: Open)*

"SG Ready" is active. The compressor in the heat pump and additional heat is blocked.

– *Normal mode (A: Open, B: Open)*

"SG Ready" is not active. No effect on the system.

– *Low price mode (A: Open, B: Closed)*

"SG Ready" is active. The system focuses on costs savings and can for example exploit a low tariff from the electricity supplier or over-capacity from any own power source (effect on the system can be adjusted in the menu 4.1.5).

– *Overcapacity mode (A: Closed, B: Closed)*

"SG Ready" is active. The system is permitted to run at full capacity at over capacity (very low price) with the electricity supplier (effect on the system is settable in menu 4.1.5).

(A = SG Ready A and B = SG Ready B)

• +Adjust

Using +Adjust, the installation communicates with the underfloor heating's control centre* and adjusts the heating curve and calculated supply temperature according to the underfloor heating system's reconnection.

Activate the climate system you want +Adjust to affect by highlighting the function and pressing the OK button.

*Support for +Adjust required



Caution

This accessory may require a software update in your VVM 320. The version can be checked in the "Service info" menu 3.1. Visit nibeuplink.com and click on the "Software" tab to download the latest software to your installation.



Caution

In systems with both underfloor heating and radiators, NIBE ECS 40/41 should be used for optimum operation.

External blocking of functions

An external switch function can be connected to VVM 320 for blocking various functions. The switch must be potential-free and a closed switch results in blocking.



NOTE

Blocking entails a risk of freezing.

Functions that can be blocked:

- hot water (hot water production). Any hot water circulation (HWC) remains in operation.
- heating (blocking of heating demand)
- cooling (blocking cooling requirement)
- internally controlled additional heat
- compressor in heat pump EB101
- tariff blocking (additional heat, compressor, heating, cooling and hot water are disconnected)

Possible selections for AUX output



Caution

The relay outputs may be subjected to a max load of 2 A at resistive load (230V AC).



TIP

The AXC accessory is required if more than one function is to be connected to the AUX output.

Indications

- alarm
- common alarm
- cooling mode indication (only applies if there are cooling accessories)
- holiday
- away mode for "smart home" (complement to the functions in menu 4.1.7)

Control

- circulation pump for hot water circulation
- active cooling in a 4-pipe system
- external heating medium pump
- additional heat in charge circuit



NOTE

The relevant distribution box must be marked with a warning about external voltage.

An external circulation pump is connected to the AUX output, as illustrated below.

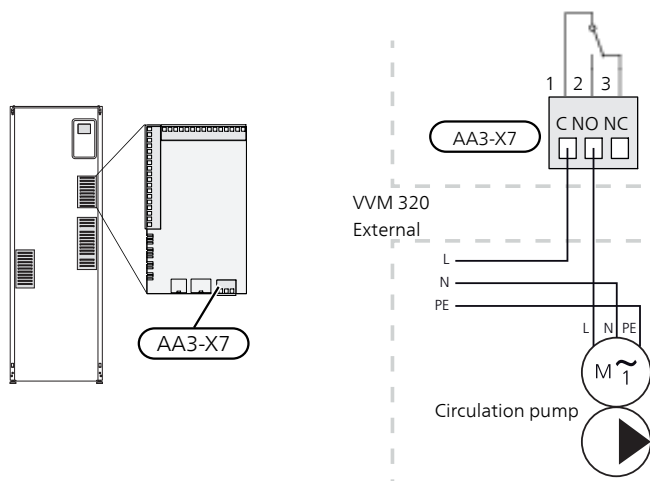

Integrated active cooling in 4-pipe system

Integrated active cooling in 4-pipe system with air/water heat pump is activated via soft output.

Active cooling is produced by the air/water heat pump's compressor.

When cooling in a 4-pipe system has been selected as soft output, menu group 1.9.5 is displayed and "cooling" must be activated for the air/water heat pump in menu 5.11.X.1, or with a DIP switch on the air/water heat pump in order to determine that it is to perform cooling.

Operating mode cooling is activated by the temperature of the outdoor temperature sensor (BT1) and any room sensor (BT50), room unit or separate room sensor for cooling (BT74) (if two different rooms are to be heated or cooled at the same time, for example.) When cooling is required, the cooling reversing valve (EQ1-QN12) and the cooling circulation pump (EQ1-GP12) in the indoor module (VVM) are activated.

Cooling production is regulated according to the cooling sensor (BT64) and a cooling set point value that is determined by the selected cooling curve. Cooling degree minutes are calculated based on the value on the external temperature sensor (BT64) for cooling out and the cooling set point value.

If the "active cooling 4-pipes" accessory has been activated, the function is switched off. Cooling is then operated from the accessory instead.

Connecting accessories

Instructions for connecting accessories are provided in the manual accompanying the accessory. See page 64 for the list of the accessories that can be used with VVM 320.

Connection for communication with the most common accessories is shown here.

ACCESSORIES WITH ACCESSORY BOARD AA5

Accessories with accessory board AA5 connect to the indoor module terminal block X4:13-15 on the input board AA3.

If several accessories are to be connected or are already installed, the following instructions must be followed.

The first accessory board must be connected directly to the indoor module's terminal block AA3-X4. The following boards must be connected to the previous board in series.

Use cable type LiYY, EKKX or similar.

Refer to the accessory manual for further instructions.

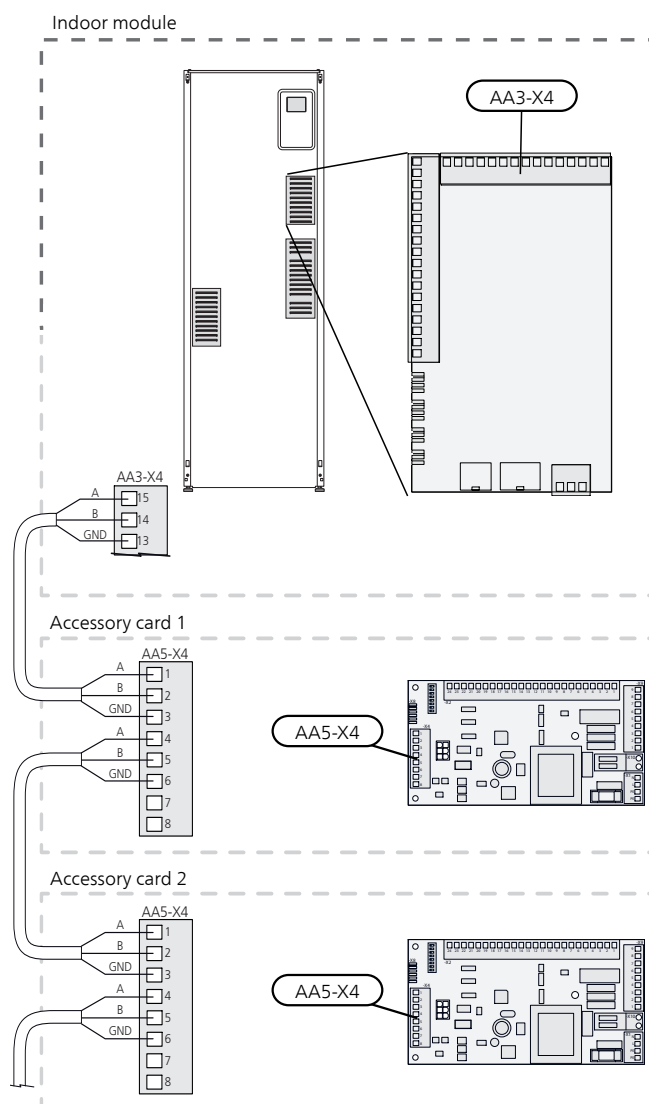

ACCESSORIES WITH ACCESSORY BOARD AA9

Connect accessory board AA9 in Modbus 40/ SMS 40/ RMU 40 to the indoor module's terminal block X4:9-12 on the input board AA3. Use cable type LiYY, EKKX or equivalent.

Refer to the accessory manual for further instructions.

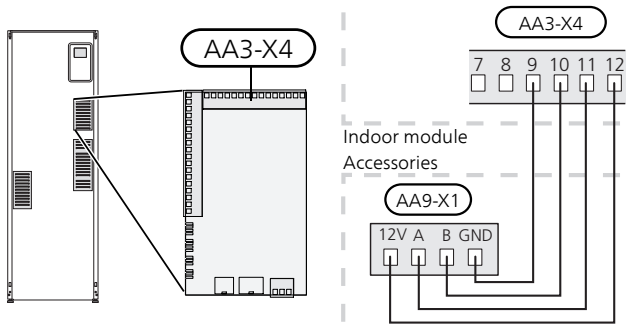

6 Commissioning and adjusting

Preparations

1. Check that the switch (SF1) is in position "⏻".
2. Check that the drain valve is fully closed and that the temperature limiter (FQ10) has not deployed.

Filling and venting

FILLING THE HOT WATER HEATER IN VVM 320

1. Open a hot water tap in the house.
2. Fill the hot water heater through the cold water connection (XL3).
3. When the water that comes out of the hot water tap is no longer mixed with air, the water heater is full and the hot water tap can be closed.

FILLING VVM 320

1. Open the vent valve (QM20).
2. Open the filler valves (QM11). VVM 320 is filled with water.
3. When the water exiting the vent valve (QM20) is no longer mixed with air, close the vent valve. After a while the pressure starts to rise on the pressure gauge. When the opening pressure for the safety valve has been reached, it starts to release water. Close the filling valve. Vent the water heater coil using the vent valve (QM22).
4. Open the safety valve until the pressure in VVM 320 falls to the normal working range (approx. 1 bar) and check that there is no air in the system by turning the vent valve (QM20).

VENTING THE CLIMATE SYSTEM

1. Turn off the power supply to VVM 320.
2. Vent VVM 320 through the vent valve (QM20) and other climate systems through their relevant vent valves.
3. Keep topping up and venting until all air has been removed and the pressure is correct.

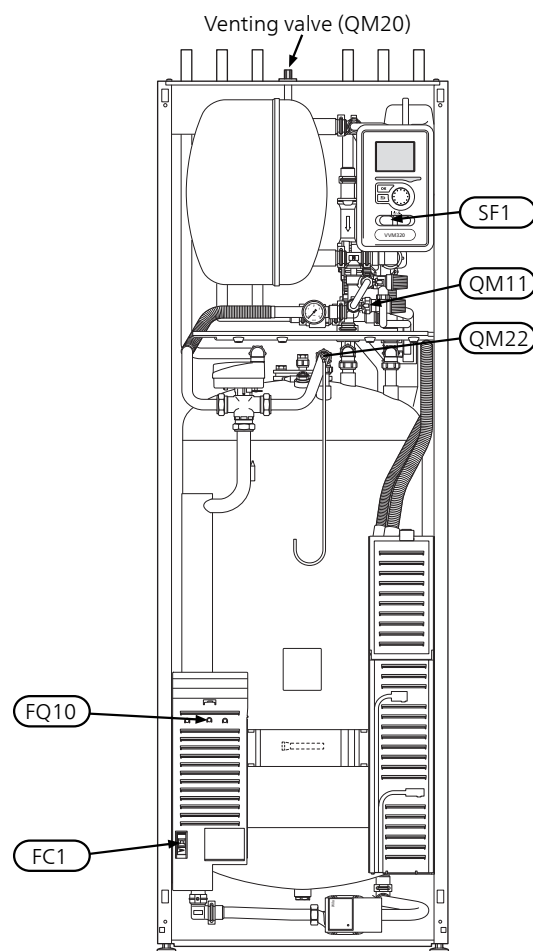

DRAINING THE CLIMATE SYSTEM

1. Connect a hose to the lower filler valve for heating medium (QM11).
2. Open the valve to drain the climate system.

Also see section "Draining the climate system".

Start-up and inspection

START GUIDE



NOTE

There must be water in the climate system before the switch is set to "I".

1. Set switch (SF1) on VVM 320 to position "I".
2. Follow the instructions in the display's start guide. If the start guide does not start when you start the VVM 320, start it manually in menu 5.7.



TIP

See the section "Control – Introduction" for a more detailed introduction to the installation's control system (operation, menus, etc.).

Commissioning

The first time the installation is started a start guide is started. The start guide instructions state what needs to be carried out at the first start together with a run through of the installation's basic settings.

The start guide ensures that the start-up is carried out correctly and, for this reason, cannot be skipped.

During the start up guide the reversing valves and the shunt valve are run backward and forwards to help vent VVM 320.



Caution

As long as the start guide is active, no function in VVM 320 will start automatically.

The start guide will appear at each restart of VVM 320, until it is deselected on the last page.

Operation in the start guide

A. Page

B. Name and menu number

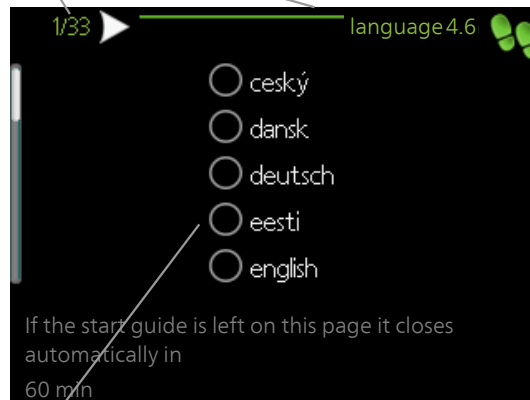

C. Option / setting

A. Page

Here you can see how far you have come in the start guide.

Scroll between the pages of the start guide as follows:

1. Turn the control knob until one of the arrows in the top left corner (at the page number) has been marked.
2. Press the OK button to skip between the pages in the start guide.

B. Name and menu number

Here, you can see which menu in the control system this page of the start guide is based on. The digits in brackets refer to the menu number in the control system.

If you want to read more about affected menus either consult the help menu or read the user manual.

C. Option / setting

Make settings for the system here.

COMMISSIONING WITHOUT HEAT PUMP

The indoor module can be used without a heat pump, i.e. only as an electric boiler, to produce heat and hot water before the heat pump is installed, for example.

Connect the pipe for docking in from the heat pump (XL8) with the pipe out to the heat pump (XL9).

Enter menu 5.2.2 System settings and deactivate the heat pump.



NOTE

Select operating mode auto or manual when the indoor module is to be used with the heat pump again.

PUMP SPEED

The circulation pump (GP1) in VVM 320 is frequency controlled and sets itself using control and based on heating demand.

Available pressure circulation pump, GP1

Available pressure
(kPa)

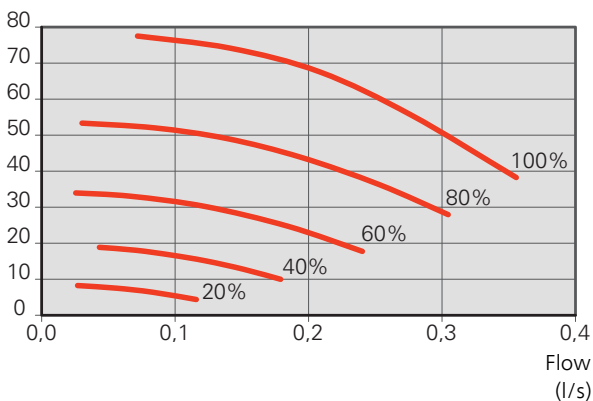

POST-ADJUSTMENT, VENTING

Initially, air is released from the hot water and venting may be necessary. If gurgling sounds can be heard from the climate system, the entire system will require additional venting. The installation is vented via vent valves (QM20), (QM22) and other climate systems through their relevant vent valves. When venting, VVM 320 must be off.

Setting the heating curve

In menu **Curve, heating** you can view the heating curve for your house. The task of the curve is to give an even indoor temperature, regardless of the outdoor temperature, and thereby energy-efficient operation. Based on this curve, the VVM 320 determines the temperature of the water to the climate system (the supply temperature) and thus the indoor temperature.

CURVE COEFFICIENT

The slope of the heating curve indicates how many degrees the supply temperature is to be increased/reduced when the outdoor temperature drops/increases. A steeper slope means a higher supply temperature at a certain outdoor temperature.

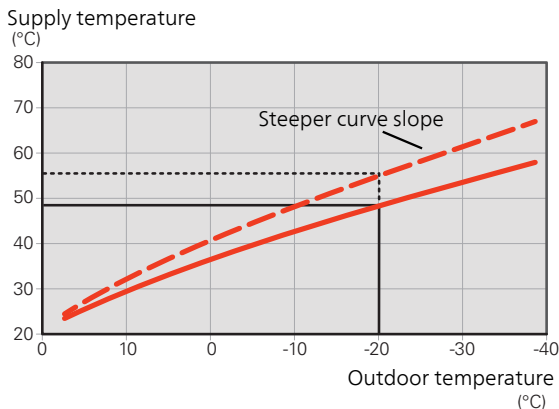

The optimum curve slope depends on the climate conditions in your location, whether the house has radiators, fan coils or underfloor heating and how well insulated the house is.

The heating curve is set when the heating installation is installed, but may need adjusting later. Normally, the curve will not need further adjustment.

CURVE OFFSET

An offset of the heating curve means that the supply temperature is changed by the same amount for all outdoor temperatures, e.g. a curve offset of +2 steps increases the supply temperature by 5 °C at all outdoor temperatures.

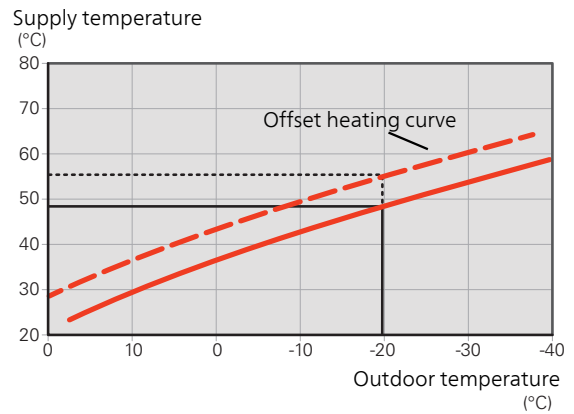

SUPPLY TEMPERATURE – MAXIMUM AND MINIMUM VALUES

Because the flow line temperature cannot be calculated higher than the set maximum value or lower than the set minimum value the heating curve flattens out at these temperatures.

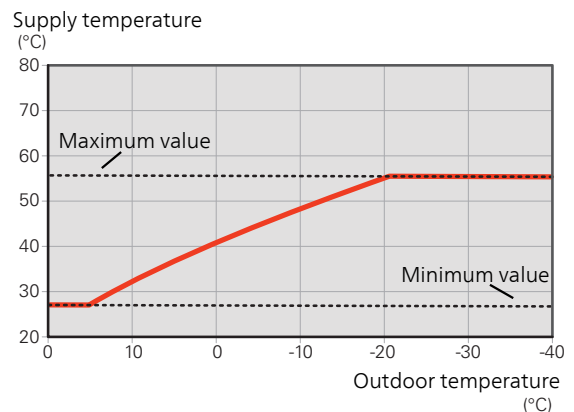

Caution

With underfloor heating systems, the maximum supply temperature is normally set between 35 and 45 °C.

Check the max floor temperature with your floor supplier.

ADJUSTMENT OF CURVE

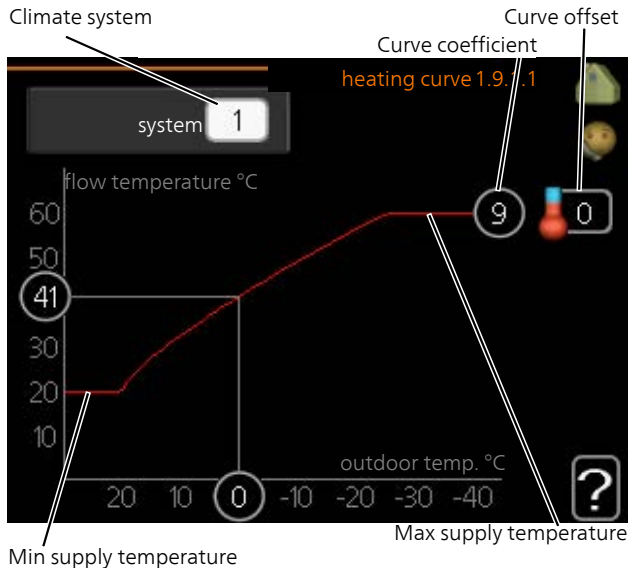

1. Select the climate system (if more than one) for which the curve is to be changed.
2. Select curve slope and curve offset.



Caution

If you need to adjust "min. flow line temp." and/or "max flow line temperature", you do this in other menus.

Settings for "min. flow line temp." in menu 1.9.3.

Settings for "max flow line temperature" in menu 5.1.2.



Caution

Curve 0 means that **own curve** is used.

Settings for **own curve** are made in menu 1.9.7.

TO READ OFF A HEATING CURVE

1. Turn the control knob so that the ring on the shaft with the outdoor temperature is marked.
2. Press the OK button.
3. Follow the grey line up to the curve and out to the left to read off the value for the supply temperature at the selected outdoor temperature.
4. You can now select to take read outs for different outdoor temperatures by turning the control knob to the right or left and read off the corresponding flow temperature.
5. Press the OK or Back button to exit read off mode.

Cooling in 2-pipe system

VVM 320 contains a built-in function for operating cooling in a 2-pipe system down to 17 °C, factory setting 18 °C. This requires that the outdoor module can perform cooling. (See the Installer Manual for your air/water heat pump.) If the outdoor module can perform cooling, the cooling menus are activated in the display on the indoor module (VVM).

In order for operating mode "cooling" to be permitted, the average temperature must be above the setting value for "start cooling" in menu 4.9.2

The cooling settings for the climate system are adjusted in the indoor climate menu, menu 1.

Setting hot water circulation

operating time

Setting range: 1 – 60 min

Factory setting: 60 min

downtime

Setting range: 0 – 60 min

Factory setting: 0 min

Set the hot water circulation for up to three periods per day here. During the set periods the hot water circulation pump will run according to the settings above.

"operating time" decide how long the hot water circulation pump must run per operating instance.

"downtime" decide how long the hot water circulation pump must be stationary between operating instances.



NOTE

Hot water circulation is activated in menu 5.4 "soft inputs and outputs".

Pool

POOL (ACCESSORY IS REQUIRED)

start temp

Setting range: 5.0 – 80.0 °C

Factory setting: 22.0 °C

stop temperature

Setting range: 5.0 – 80.0 °C

Factory setting: 24.0 °C

Select whether the pool control is to be activated and within what temperatures (start and stop temperature) pool heating must occur.

When the pool temperature drops below the set start temperature and there is no hot water or heating requirement, VVM 320 starts pool heating.

Untick "activated" to switch off the pool heating.



Caution

The start temperature cannot be set to a value that is higher than the stop temperature.

SG Ready

This function can only be used in mains networks that support the "SG Ready"-standard .

Make settings for the function "SG Ready" here.

Low price mode means that the electricity supplier has a low tariff and the system uses this to reduce costs.

Over capacity mode means that the electricity supplier has set the tariff very low and the system uses this to reduce the costs as much as possible.

affect room temperature

Here you set whether room temperature should be affected when activating "SG Ready".

With low price mode on "SG Ready", the parallel offset for the indoor temperature is increased by "+1". If a room sensor is installed and activated, the desired room temperature is increased instead by 1 °C.

With overcapacity mode on "SG Ready", the parallel offset for the indoor temperature is increased by "+2". If a room sensor is installed and activated, the desired room temperature is increased instead by 2 °C.

affect hot water

Here you set whether the temperature of the hot water should be affected when activating "SG Ready".

With low price mode on "SG Ready" the stop temperature of the hot water is set as high as possible at only compressor operation (immersion heater not permitted).

With over capacity mode of "SG Ready" the hot water is set to "activate temp lux" (immersion heater permitted).

affect cooling (accessory required)

Here you set whether room temperature during cooling operation should be affected when activating "SG Ready".

With low price mode of "SG Ready" and cooling operation the indoor temperature is not affected.

With overcapacity mode on "SG Ready" and cooling operation, the parallel offset for the indoor temperature is decreased by "-1". If a room sensor is installed and activated, the desired room temperature is decreased instead by 1 °C.

affect pool temperature (accessory is required)

Here you set whether pool temperature should be affected when activating "SG Ready".

With low price mode on "SG Ready", the desired pool temperature (start and stop temperature) is increased by 1 °C.

With overcapacity mode on "SG Ready", the desired pool temperature (start and stop temperature) is increased by 2 °C.



NOTE

The function must be connected to two AUX inputs and activated in menu 5.4.

7 Control - Introduction

Display unit

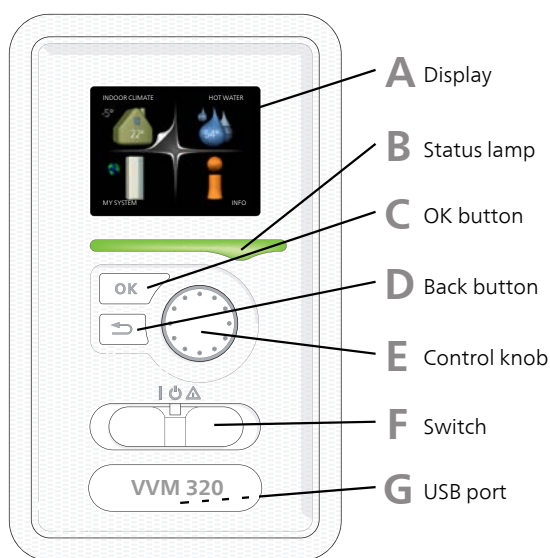

A DISPLAY

Instructions, settings and operational information are shown on the display. You can easily navigate between the different menus and options to set the comfort or obtain the information you require.

B STATUS LAMP

The status lamp indicates the status of the indoor module. It:

- lights green during normal operation.
- lights yellow in emergency mode.
- lights red in the event of a deployed alarm.

C OK BUTTON

The OK button is used to:

- confirm selections of sub menus/options/set values/page in the start guide.

D BACK BUTTON

The back button is used to:

- go back to the previous menu.
- change a setting that has not been confirmed.

E CONTROL KNOB

The control knob can be turned to the right or left. You can:

- scroll in menus and between options.
- increase and decrease the values.
- change page in multiple page instructions (for example help text and service info).

F SWITCH (SF1)

The switch assumes three positions:

- On (I)
- Standby (⏻)
- Emergency mode (⚠)

Emergency mode must only be used in the event of a fault on the indoor module. In this mode, the compressor switches off and the immersion heater engages. The indoor module display is not illuminated and the status lamp illuminates yellow.

G USB PORT

The USB port is hidden beneath the plastic badge with the product name on it.

The USB port is used to update the software.

Visit nibeuplink.com and click the "Software" tab to download the latest software for your installation.

Menu system

When the door to the indoor module is opened, the menu system's four main menus are shown in the display as well as certain basic information.

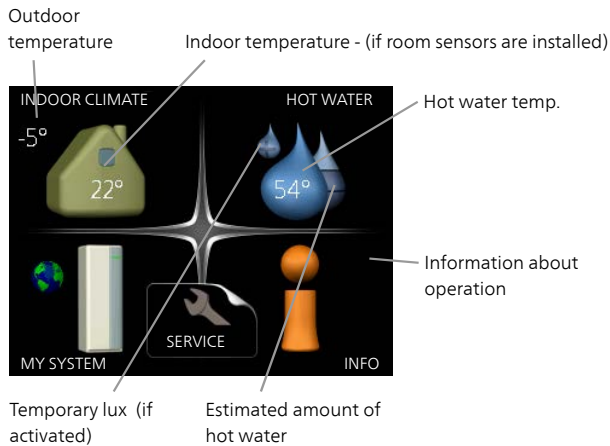

MENU 1 - INDOOR CLIMATE

Setting and scheduling the indoor climate. See information in the help menu or user manual.

MENU 2 - HOT WATER

Setting and scheduling hot water production. See information in the help menu or user manual.

MENU 3 - INFO

Display of temperature and other operating information and access to the alarm log. See information in the help menu or user manual.

MENU 4 - MY SYSTEM

Setting time, date, language, display, operating mode etc. See information in the help menu or user manual.

MENU 5 - SERVICE

Advanced settings. These settings are not available to the end user. The menu is visible when the Back button is pressed for 7 seconds, when you are in the start menu. See page 47.

SYMBOLS IN THE DISPLAY

The following symbols can appear in the display during operation.

Symbol	Description
	This symbol appears by the information sign if there is information in menu 3.1 that you should note.
	These two symbols indicate whether the compressor in the outdoor module or additional heat is blocked in VVM 320. These can, for example, be blocked depending on which operating mode is selected in menu 4.2, if blocking is scheduled in menu 4.9.5 or if an alarm has occurred that blocks one of them. Blocking the compressor. Blocking additional heat.
	This symbol appears if periodic increase or lux mode for the hot water is activated.
	This symbol indicates whether "holiday setting" is active in 4.7.
	This symbol indicates whether VVM 320 has contact with NIBE Uplink.
	This symbol indicates the actual speed of the fan if the speed has changed from the normal setting. Accessory needed.
	This symbol is visible in installations with active solar accessories.
	This symbol indicates whether pool heating is active. Accessory needed.
	This symbol indicates whether cooling is active. Heat pump with cooling function required.

OPERATION

To move the cursor, turn the control knob to the left or the right. The marked position is white and/or has a turned up tab.



SELECTING MENU

To advance in the menu system select a main menu by marking it and then pressing the OK button. A new window then opens with sub menus.

Select one of the sub menus by marking it and then pressing the OK button.

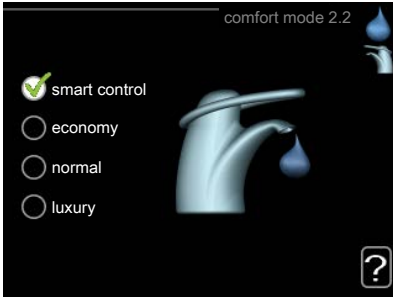

SELECTING OPTIONS



In an options menu the current selected option is indicated by a green tick.



To select another option:





1. Mark the applicable option. One of the options is pre-selected (white). 
2. Press the OK button to confirm the selected option. The selected option has a green tick. 

SETTING A VALUE



Values to be changed

To set a value:

1. Mark the value you want to set using the control knob. 
2. Press the OK button. The background of the value becomes green, which means that you have accessed the setting mode. 
3. Turn the control knob to the right to increase the value and to the left to reduce the value. 
4. Press the OK button to confirm the value you have set. To change and return to the original value, press the Back button. 

USE THE VIRTUAL KEYBOARD

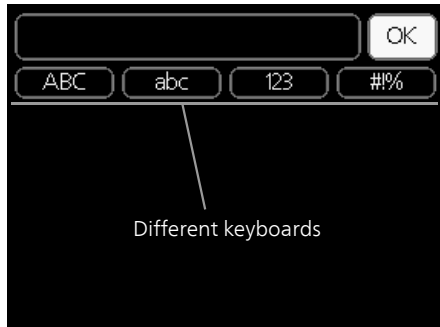

In some menus where text may require entering, a virtual keyboard is available.



Depending on the menu, you can gain access to different character sets which you can select using the control knob. To change character table, press the Back button. If a menu only has one character set the keyboard is displayed directly.

When you have finished writing, mark "OK" and press the OK button.

SCROLL THROUGH THE WINDOWS

A menu can consist of several windows. Turn the control knob to scroll between the windows.

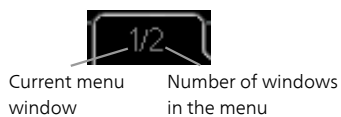

Scroll through the windows in the start guide



Arrows to scroll through window in start guide

1. Turn the control knob until one of the arrows in the top left corner (at the page number) has been marked.
2. Press the OK button to skip between the steps in the start guide.

HELP MENU

 In many menus there is a symbol that indicates that extra help is available.

To access the help text:

1. Use the control knob to select the help symbol.
2. Press the OK button.

The help text often consists of several windows that you can scroll between using the control knob.

8 Control – Menus

Menu 1 - INDOOR CLIMATE

1 - INDOOR CLIMATE	1.1 - temperature	1.1.1 - heating	
		1.1.2 - cooling *	
		1.1.3 - rel. humidity *	
	1.2 - ventilation *		
	1.3 - scheduling	1.3.1 - heating	
		1.3.2 - cooling *	
		1.3.3 - ventilation *	
	1.9 - advanced	1.9.1 - curve	1.9.1.1 heating curve
			1.9.1.2 - cooling curve *
		1.9.2 - external adjustment	
		1.9.3 - min. flow line temp.	1.9.3.1 - heating
		1.9.3.2 - cooling *	
	1.9.4 - room sensor settings		
	1.9.5 - cooling settings *		
	1.9.6 - fan return time *		
	1.9.7 - own curve	1.9.7.1 - heating	
		1.9.7.2 - cooling *	
	1.9.8 - point offset		
	1.9.9 - night cooling *		
	1.9.11 - +Adjust		

* Accessories are needed.

Menu 2 - HOT WATER

2 - HOT WATER

2.1 - temporary lux

2.2 - comfort mode

2.3 - scheduling

2.9 - advanced

2.9.1 - periodic increase

2.9.2 - hot water recirc.

Menu 3 - INFO

3 - INFO

3.1 - service info

3.2 - compressor info

3.3 - add. heat info

3.4 - alarm log

3.5 - indoor temp. log

* Accessories are needed.

Menu 4 - MY SYSTEM

4 - MY SYSTEM	4.1 - plus functions	4.1.1 - pool *
		4.1.3 - internet
		4.1.3.1 - NIBE Uplink
		4.1.3.8 - tcp/ip settings
		4.1.3.9 - proxy settings
		4.1.4 - sms *
		4.1.5 - SG Ready
		4.1.6 - smart price adaptation™
		4.1.7 - smart home
		4.1.8 - smart energy source™
		4.1.8.1 - settings
		4.1.8.2 - set. price
		4.1.8.3 - CO2 impact
		4.1.8.4 - tariff periods, electricity
		4.1.8.6 - tariff per, ext. shunt add
		4.1.8.7 - tariff per, ext. step add
		4.1.8.8 - tariff periods, OPT10
		Menu 4.1.10 – solar electricity *
	4.2 - op. mode	
	4.3 - my icons	
	4.4 - time & date	
	4.6 - language	
	4.7 - holiday setting	
	4.9 - advanced	4.9.1 - op. prioritisation
		4.9.2 - auto mode setting
		4.9.3 - degree minute setting
		4.9.4 - factory setting user
		4.9.5 - schedule blocking
		4.9.6 - schedule silent mode
		4.9.7 – tools

* Accessory needed.

Descriptions of menu 1–4 can be found in the user handbook.

Menu 5 - SERVICE

OVERVIEW

5 - SERVICE	5.1 - operating settings	5.1.1 - hot water settings	
		5.1.2 - max flow line temperature	
		5.1.3 - max diff flow line temp.	
		5.1.4 - alarm actions	
		5.1.5 - fan sp. exhaust air *	
		5.1.12 - internal electrical addition	
		5.1.13 - max inst. el.pwr (BBR)	
		5.1.14 - flow set. climate system	
		5.1.18 - flow setting charge pump	
		5.1.22 - heat pump testing	
		5.1.23 - compressor curve	
		5.1.25 - time filter alarm*	
	5.2 - system settings	5.2.2 - installed heat pump	
		5.2.4 - accessories	
	5.3 - accessory settings	5.3.2 - shunt controlled add. heat *	
		5.3.3 - extra climate system *	
		5.3.6 - step controlled add. heat *	
		5.3.7 - external addition *	
		5.3.8 - hot water comfort *	
		5.3.11 - modbus *	
		5.3.12 - exhaust/supply air module *	
		5.3.14 - F135 *	
		5.3.15 - GBM communications module *	
		5.3.16 - humidity sensor *	
		5.3.18 - pool*	
		5.3.19 - active cooling 4 pipe*	
		5.3.21 - flow sensor / energy meter*	
	5.4 - soft in/outputs		
	5.5 - factory setting service		
	5.6 - forced control		
	5.7 - start guide		
	5.8 - quick start		
	5.9 - floor drying function		
	5.10 - change log		
	5.11 -heat pump settings	5.11.1 - EB101	5.11.1.1 - heat pump
			5.11.1.2 - heating medium pump (GP1)
	5.12 - country		

* Accessory needed.

Go to the main menu and hold the Back button in for 7 seconds to access the Service menu.

Sub-menus

Menu **SERVICE** has orange text and is intended for the advanced user. This menu has several sub-menus. Status information for the relevant menu can be found on the display to the right of the menus.

operating settings Operating settings for the indoor module.

system settings System settings for the indoor module, activating accessories etc.

accessory settings Operational settings for different accessories.

soft in/outputs Setting software controlled in and outputs on the input circuit board (AA3).

factory setting service Total reset of all settings (including settings available to the user) to default values.

forced control Forced control of the different components in the indoor module.

start guide Manual start of the start guide which is run the first time when the indoor module is started.

quick start Quick starting the compressor.



NOTE

Incorrect settings in the service menus can damage the installation.

MENU 5.1 - OPERATING SETTINGS

Operating settings can be made for the indoor module in the sub menus.

MENU 5.1.1 - HOT WATER SETTINGS

VVM 320 Stainless steel or VVM 320 Enamel

economy

Setting range start temp. economy: 5 – 70 °C

Factory setting start temp. economy: 40 °C

Setting range stop temp. economy: 5 – 70 °C

Factory setting stop temp. economy: 44 °C

normal

Setting range start temp. normal: 5 – 70 °C

Factory setting start temp. normal: 44 °C

Setting range stop temp. normal: 5 – 70 °C

Factory setting stop temp. normal: 48 °C

luxury

Setting range start temp. lux: 5 – 70 °C

Factory setting start temp. lux: 47 °C

Setting range stop temp. lux: 5 – 70 °C

Factory setting stop temp. lux: 51 °C

stop temp. per. increase

Setting range: 55 – 70 °C

Factory setting: 55 °C

Here you set the start and stop temperature of the hot water for the different comfort options in menu 2.2 as well as the stop temperature for periodic increase in menu 2.9.1.

MENU 5.1.2 - MAX FLOW LINE TEMPERATURE

climate system

Setting range: 5-80 °C

Default value: 60 °C

Set the maximum supply temperature for the climate system here. If the installation has more than one climate system, individual maximum supply temperatures can be set for each system. Climate systems 2 - 8 cannot be set to a higher max supply temperature than climate system 1.



Caution

For underfloor heating systems, max flow line temperature should normally be set to between 35 and 45°C.

Check the max floor temperature with your floor supplier.

MENU 5.1.3 - MAX DIFF FLOW LINE TEMP.

max diff compressor

Setting range: 1 – 25 °C

Default value: 10 °C

max diff addition

Setting range: 1 – 24 °C

Default value: 7 °C

Here you set the maximum permitted difference between the calculated and actual supply temperature in the event of compressor or additional heat mode respectively. Max diff. additional heat can never exceed max diff. compressor

max diff compressor

If the current supply temperature *exceeds* the calculated supply by set value, the degree minute value is set to +2. The compressor in the heat pump stops if there is only a heating demand.

max diff addition

If "addition" is selected and activated in menu 4.2 and the current supply temperature *exceeds* the calculated temperature by the set value, the additional heat is forced to stop.

MENU 5.1.4 - ALARM ACTIONS

Select if you want the indoor module to alert you that there is an alarm in the display here.



Caution

If no alarm action is selected, it can result in higher energy consumption in the event of an alarm.

MENU 5.1.5 - FAN SP. EXHAUST AIR (ACCESSORY IS REQUIRED)

normal and speed 1-4

Setting range: 0 – 100 %

Factory setting normal: 65 %

Factory setting speed 1: 0 %

Factory setting speed 2: 30 %

Factory setting speed 3: 80 %

Factory setting speed 4: 100 %

Set the speed for the four different selectable modes for the fan here.



Caution

An incorrectly set ventilation flow can damage the house and may also increase energy consumption.

MENU 5.1.12 - INTERNAL ELECTRICAL ADDITION

max connected el. add.

Factory setting 3x400V: 9 kW

Factory setting 3x230V: 9 kW

Factory setting 1x230V: 7 kW

fuse size

Setting range: 1 - 200 A

Factory setting 3x400V: 16 A

Factory setting 3x230V: 32 A

Factory setting 1x230V: 32 A

Here you set the max. electrical output of the internal electrical addition in VVM 320 and the fuse size for the installation.

Here you can also check which current sensor is installed on which incoming phase to the property (this requires current sensors to be installed, see page 28). Check by selecting "detect phase order" and pressing the OK button.

The results of these checks appear just below the menu selection "detect phase order".

MENU 5.1.13 - MAX INST. EL.PWR (BBR)

max installed el.pwr (only this machine)

Setting range: 0.000 - 30.000 kW

Default values: 15.000 kW

If the above building regulations are not applicable, do not use this setting.

In order to meet certain building regulations, it is possible to lock the device's maximum power output. In this menu, you can set the value corresponding to the heat pump's maximum power connection for heating, hot water and cooling, if applicable. Note whether there are also external electrical components that are to be included. After the value has been locked, a weeks cooling-off period starts. After this period, parts in the machine must be replaced in order to obtain greater power.

MENU 5.1.14 - FLOW SET. CLIMATE SYSTEM

presettings

Setting range: radiator, floor heat., rad. + floor heat., DOT °C

Default value: radiator

Setting range DOT: -40.0 – 20.0 °C

Factory setting DOT: -18.0 °C

own setting

Setting range dT at DOT: 2.0 – 20.0

Factory setting dT at DOT: 10.0

Setting range DOT: -40.0 – 20.0 °C

Factory setting DOT: -18.0 °C

The type of heating distribution system the heating medium pump (GP1) works towards is set here.

dT at DOT is the difference in degrees between flow and return temperatures at dimensioned outdoor temperature.

MENU 5.1.18 - FLOW SETTING CHARGE PUMP

Check that the flow for the charge pump through the heat pump is sufficient. Activate the flow test to measure delta (the difference between the flow and return line temperatures from the heat pump). The test is OK if delta lies below the parameter shown in the display.



NOTE

The hot water temperature (BT6) must be below 40 °C in order for the flow test to start.

MENU 5.1.22 - HEAT PUMP TESTING



NOTE

This menu is intended for testing VVM 320 according to different standards.

Use of this menu for other reasons may result in your installation not functioning as intended.

This menu contains several sub-menus, one for each standard.

MENU 5.1.23 - COMPRESSOR CURVE



Caution

This menu is only displayed if VVM 320 is connected to a heat pump with inverter controlled compressor.

Set whether the compressor in the heat pump should work to a particular curve under specific requirements or if it should work to predefined curves.

You set a curve for a demand (heat, hot water etc.) by unticking "auto", turning the control knob until a temperature is marked and pressing OK. You can now set at what temperatures the max. and min. frequencies, respectively will occur.

This menu can consist of several windows (one for each available demand), use the navigation arrows in the top left corner to change between the windows.

MENU 5.1.25 - TIME FILTER ALARM

months btwn filter alarms

Setting range: 1 – 24

Factory setting: 3

Here you set the number of months between alarms for a reminder to clean the filter in a connected accessory.

MENU 5.2 - SYSTEM SETTINGS

Make different system settings for your installation here, e.g. activate the connected heat pump and which accessories are installed.

MENU 5.2.2 - INSTALLED HEAT PUMP

If an air/water heat pump is connected to the indoor module, activate it here.

MENU 5.2.4 - ACCESSORIES

Set which accessories are installed on the installation here.

There are two ways of activating connected accessories. You can either mark the alternative in the list or use the automatic function "search installed acc.".

search installed acc.

Mark "search installed acc." and press the OK button to automatically find connected accessories for VVM 320.

MENU 5.3 - ACCESSORY SETTINGS

The operating settings for accessories that are installed and activated are made in the sub-menus for this.

MENU 5.3.2 - SHUNT CONTROLLED ADD. HEAT

prioritised additional heat

Setting range: on/off

Factory setting: off

start diff additional heat

Setting range: 0 – 2000 DM

Default values: 400 DM

minimum running time

Setting range: 0 – 48 h

Default value: 12 h

min temp.

Setting range: 5 – 90 °C

Default value: 55 °C

mixing valve amplifier

Setting range: 0.1 – 10.0

Default value: 1.0

mixing valve step delay

Setting range: 10 – 300 s

Default values: 30 s

Set when the addition is to start, the minimum run time and the minimum temperature for external addition with shunt here. External addition with shunt is for example a wood/oil/gas/pellet boiler.

You can set shunt valve amplification and shunt valve waiting time.

Selecting "prioritised additional heat" uses the heat from the external additional heat instead of the heat pump. The shunt valve is regulated as long as heat is available, otherwise the shunt valve is closed.



TIP

See the accessory installation instructions for function description.

MENU 5.3.3 - EXTRA CLIMATE SYSTEM

use in heating mode

Setting range: on/off

Factory setting: on

use in cooling mode

Setting range: on/off

Factory setting: off

mixing valve amplifier

Setting range: 0.1 – 10.0

Default value: 1.0

mixing valve step delay

Setting range: 10 – 300 s

Default values: 30 s

Contr. pump GP10

Setting range: on/off

Factory setting: off

Here, you select which climate system (2 - 8) you wish to set.

use in heating mode: If the heat pump is connected to a climate system(s) for cooling, any condensation can take place in this/these. Check that "use in heating mode" has been selected for the climate system(s) that is/are not adapted for cooling. This setting means that the sub-shunt for the extra climate system closes when cooling operation is activated.

use in cooling mode: Select "use in cooling mode" for climate systems that are adapted to handle cooling. For 2-pipe cooling you can select both "use in cooling mode" and "use in heating mode", while for 4-pipe cooling you can only select one option.



Caution

This setting option only appears if the heat pump is activated for cooling operation in menu 5.2.4..

mixing valve amplifier, mixing valve step delay: Here, you set the shunt amplification and shunt waiting time for the various extra climate systems that are installed.

Contr. pump GP10: Here, you can set the speed of the circulation pump manually.

See the accessory installation instructions for function description.

MENU 5.3.6 - STEP CONTROLLED ADD. HEAT

start diff additional heat

Setting range: -2000 – -30 DM

Default values: -400 DM

diff. between additional steps

Setting range: 0 – 1000 DM

Default values: 100 DM

max step

Setting range

(binary stepping deactivated): 0 – 3

Setting range

(binary stepping activated): 0 – 7

Default value: 3

binary stepping

Setting range: on/off

Factory setting: off

Make settings for step controlled addition here. Step controlled addition is for example an external electric boiler.

It is possible, for example, to select when the additional heat is to start, to set the maximum number of permitted steps and whether binary stepping is to be used.

When binary stepping is deactivated (off), the settings refer to linear stepping.

See the accessory installation instructions for function description.

MENU 5.3.7 - EXTERNAL ADDITION

Make settings for external addition here. External addition is for example external oil, gas or electric boiler.

If the external addition is not step controlled, in addition to selecting when this should start also set the run time for the addition.

If the external addition is step controlled you can select when the addition is to start, set the maximum number of permitted steps and whether binary stepping is to be used.

If you select "prioritised additional heat" the heat is used from the external addition instead of the heat pump.

See the accessory installation instructions for function description.

MENU 5.3.8 - HOT WATER COMFORT

activating the mixing valve

Setting range: on/off

Factory setting: off

outgoing hot water

Setting range: 40 - 65 °C

Default value: 55 °C

mixing valve amplifier

Setting range: 0.1 – 10.0

Default value: 1.0

mixing valve step delay

Setting range: 10 – 300 s

Default values: 30 s

Make settings for the hot water comfort here.

See the accessory installation instructions for function description.

activating the mixing valve: Activated if mixer valve is installed and it is to be controlled from VVM 320. When the option is active, you can set the outgoing hot water temperature, shunt amplification and shunt waiting time for the mixer valve.

outgoing hot water: Here, you can set the temperature at which the mixer valve is to restrict hot water from the water heater.

MENU 5.3.11 - MODBUS

address

Factory setting: address 1

word swap

Factory setting: not activated

As from Modbus 40 version 10, the address can be set between 1 - 247. Earlier versions have a fixed address (address 1).

Here, you can select if you want to have "word swap" instead of the preset standard "big endian".

See the accessory installation instructions for function description.

MENY 5.3.12 - EXHAUST/SUPPLY AIR MODULE

months btwn filter alarms

Setting range: 1 – 24

Default value: 3

lowest extract air temp.

Setting range: 0 – 10 °C

Default value: 5 °C

bypass at excess temperature

Setting range: 2 – 10 °C

Default value: 4 °C

bypass during heating

Setting range: on/off

Factory setting: off

cut-out value, exh. air temp.

Setting range: 5 – 30 °C

Default value: 25 °C

months btwn filter alarms: Set how often the filter alarm is to be displayed.

lowest extract air temp.: Set the minimum extract air temperature to prevent the heat exchanger freezing.

bypass at excess temperature: If a room sensor is installed, set the excess temperature at which the bypass damper is to open here.



TIP

See the installation instructions for ERS and HTS for a function description.

MENU 5.3.14 - F135

charge pump speed

Setting range: 1 – 100 %

Factory setting: 70 %

hot water at cooling

Setting range: on/off

Factory setting: off

Here you can set the charge pump speed for F135. You can also choose whether you want to be able to charge hot water with F135 at the same time as the outdoor module produces cooling.



Caution

It is necessary for "active cooling 4 pipe" to be selected in either "accessories" or "soft in/outputs" to enable activation of "hot water during cooling". The heat pump must also be activated for cooling operation.

MENU 5.3.15 - GBM COMMUNICATION MODULE

start diff additional heat

Setting range: 10 – 2,000 DM

Factory setting: 400 DM

hysteresis

Setting range: 10 – 2,000 DM

Factory setting: 100 DM

Make settings for the gas boiler GBM 10-15 here. For example . you can select when the gas boiler is to start. See the accessory installation instructions for a description of function.

MENU 5.3.16 - HUMIDITY SENSOR

climate system 1 HTS

Setting range: 1–4

Default value: 1

limit RH in the room, syst.

Setting range: on/off

Factory setting: off

prevent condensation, syst.

Setting range: on/off

Factory setting: off

limit RH in the room, syst.

Setting range: on/off

Factory setting: off

Up to four humidity sensors (HTS 40) can be installed. Here you select whether your system(s) is/are to limit the relative humidity level (RH) during heating or cooling operation.

You can also choose to limit min. cooling supply and calculated cooling supply to prevent condensation on pipes and components in the cooling system.

See the Installer Manual for HTS 40 for function description.

MENU 5.3.18 - POOL

Here you select which pump to use in the system.

MENU 5.3.19 - ACTIVE COOLING 4 PIPE

Here you select which pump to use in the system.

MENU 5.3.21 - FLOW SENSOR / ENERGY METER

Supply temperature sensor

set mode

Setting range: EMK150 / EMK300/310 / EMK500

Factory setting: EMK150

energy per pulse

Setting range: 0 – 10000 Wh

Factory setting: 1000 Wh

pulses per kWh

Setting range: 1 – 10000

Factory setting: 500

Energy meter

set mode

Setting range: energy per pulse / pulses per kWh

Default value: energy per pulse

energy per pulse

Setting range: 0 – 10000 Wh

Factory setting: 1000 Wh

pulses per kWh

Setting range: 1 – 10000

Factory setting: 500

Up to two flow sensors (EMK) / energy meters can be connected on the input board AA3, terminal block X22 and X23. Select these in menu 5.2.4 - accessories.

Flow sensor (Energy measurement kit EMK)

A flow sensor (EMK) is used to measure the amount of energy produced and supplied by the heating installation for hot water and heating in the building.

The function of the flow sensor is to measure flow and temperature differences in the charge circuit. The value is presented in the display on a compatible product.

Starting from software version 9085R2, you can select the flow sensor (EMK) you have connected in the system.

energy per pulse: Here you set the amount of energy to which each pulse will correspond.

pulses per kWh: Here you set the number of pulses per kWh that are sent to VVM 320.



Caution

The software in VVM 320 must be software version 9085R2 or later. Visit nibeuplink.com and click on the "Software" tab to download the latest software to your installation.

Energy meter (Electricity meter)

The energy meter(s) is used to send pulse signals every time a certain amount of energy has been consumed.

energy per pulse: Here you set the amount of energy to which each pulse will correspond.

pulses per kWh: Here you set the number of pulses per kWh that are sent to VVM 320.

MENU 5.4 - SOFT IN/OUTPUTS

Here you can select which input/output on the input board (AA3) the external contact function (page 28) must be connected to.

Selectable inputs on terminal block AUX 1-5 (AA3-X6:9-18) and output AA3-X7 on the input board.

MENU 5.5 - FACTORY SETTING SERVICE

All settings can be reset (including settings available to the user) to default values here.



Caution

When resetting, the start guide is displayed the next time the indoor module is restarted.

MENU 5.6 - FORCED CONTROL

You can force control the different components in the indoor module and any connected accessories here.



NOTE

Forced control is only intended to be used for troubleshooting purposes. Using the function in any other way may cause damage to the components in your climate system.

MENU 5.7 - START GUIDE

When the indoor module is started for the first time the start guide starts automatically. Start it manually here.

See page 35 for more information about the start guide.

MENU 5.8 - QUICK START

It is possible to start the compressor from here.



Caution

There must be a heating, cooling or hot water demand to start the compressor.



NOTE

Do not quick start the compressor too many times over a short period of time, as this could damage the compressor and its surrounding equipment.

MENU 5.9 - FLOOR DRYING FUNCTION

length of period 1 – 7

Setting range: 0 – 30 days

Factory setting, period 1 – 3, 5 – 7: 2 days

Factory setting, period 4: 3 days

temp. period 1 – 7

Setting range: 15 – 70 °C

Default value:

temp. period 1	20 °C
temp. period 2	30 °C
temp. period 3	40 °C
temp. period 4	45 °C
temp. period 5	40 °C
temp. period 6	30 °C
temp. period 7	20 °C

Set the function for under floor drying here.

You can set up to seven period times with different calculated flow temperatures. If less than seven periods are to be used, set the remaining period times to 0 days.

Mark the active window to activate the underfloor drying function. A counter at the bottom shows the number of days the function has been active.



NOTE

During under floor drying, the heating medium pump in 100% runs, regardless of the setting in menu 5.1.10.



TIP

If operating mode "add. heat only" is to be used, select it in menu 4.2.



TIP

It is possible to save a floor drying log that shows when the concrete slab has reached the correct temperature. See section "Logging floor drying" on page 59.

MENU 5.10 - CHANGE LOG

Read off any previous changes to the control system here.

The date, time, ID no. (unique to particular setting) and the new set value are shown for every change.



Caution

The change log is saved at restart and remains unchanged after factory setting.

MENU 5.11 - HEAT PUMP SETTINGS

Settings for installed heat pump can be made in the submenus.

MENU 5.11.1 - EB101

Make settings specifically for the installed heat pump and heating medium pump here.

MENU 5.11.1.1 - HEAT PUMP

Make settings for the installed heat pump here. To see what settings you can make, see the installation manual for the heat pump.

MENU 5.11.1.2 - HEATING MEDIUM PUMP (GP1)

op. mode

Setting range: auto / intermittent

Default value: auto

Set the operating mode of the heating medium pump here.

auto: The heating medium pump runs according to the current operating mode for VVM 320.

intermittent: The heating medium pump starts and stops 20 seconds before, and after, the compressor in the heat pump.

speed during operation

heating, hot water, pool, cooling

Setting range: auto / manual

Default value: auto

Manual setting

Setting range: 1–100 %

Default values: 70 %

min. allowed speed

Setting range: 1–100 %

Default values: 1 %

speed in prio. add. heat

Setting range: 1–100 %

Default values: 70 %

speed in wait mode

Setting range: 1–100 %

Default values: 30 %

max. allowed speed

Setting range: 80–100 %

Default values: 100 %

Set the speed at which the heating medium pump is to operate in the present operating mode. Select "auto" if the speed of the heating medium pump is to be regulated automatically (factory setting) for optimal operation.

If "auto" is activated for heating operation, you can also make the setting "min. allowed speed" and "max. allowed speed", which restricts the heating medium pump and does not allow it to run at a higher speed than the set value.

For manual operation of the heating medium pump, deactivate "auto" for the current operating mode and set the value to between 1 and 100% (the previously set value for "max. allowed speed" and "min. allowed speed" no longer applies).

wait mode means heating or cooling operating mode for the heating medium pump, when the heat pump requires neither compressor operation nor electric additional heat and slows down.

5.12 - COUNTRY

Select here the country in which the product was installed. This allows access to country-specific settings in your product.

Language settings can be made regardless of this selection.



Caution

This option locks after 24 hours, after restarting the display and during program updating.

9 Service

Service actions



NOTE

Servicing should only be carried out by persons with the necessary expertise.

When replacing components on VVM 320 only replacement parts from NIBE may be used.

EMERGENCY MODE

Emergency mode is used in event of operational interference and in conjunction with service. Hot water capacity is reduced in this mode.

Emergency mode is activated by setting switch (SF1) in mode "▲". This means that:

- The status lamp illuminates yellow.
- The display is not lit and the control computer is not connected.
- The temperature by the immersion heater is controlled by the thermostat (FQ10-BT30). It can be set to 35 or 45 °C.
- Only the circulation pumps and electric additional heat are active. The electrical additional heat power in emergency mode is set in the immersion heater board (AA1). See page 26 for instructions.

DRAINING THE HOT WATER HEATER

The siphon principle is used to empty the hot water heater. This can be done either via the drain valve on the incoming cold water pipe or by inserting a hose into the cold water connection.

DRAINING THE CLIMATE SYSTEM

In order to carry out service on the climate system, it may be easier to drain the system first using the filler valve (QM11).



NOTE

There may be some hot water when draining the heating medium side/climate system. There is a risk of scalding.

1. Connect a hose to the lower filler valve for heating medium (QM11).
2. Open the valve to drain the climate system.

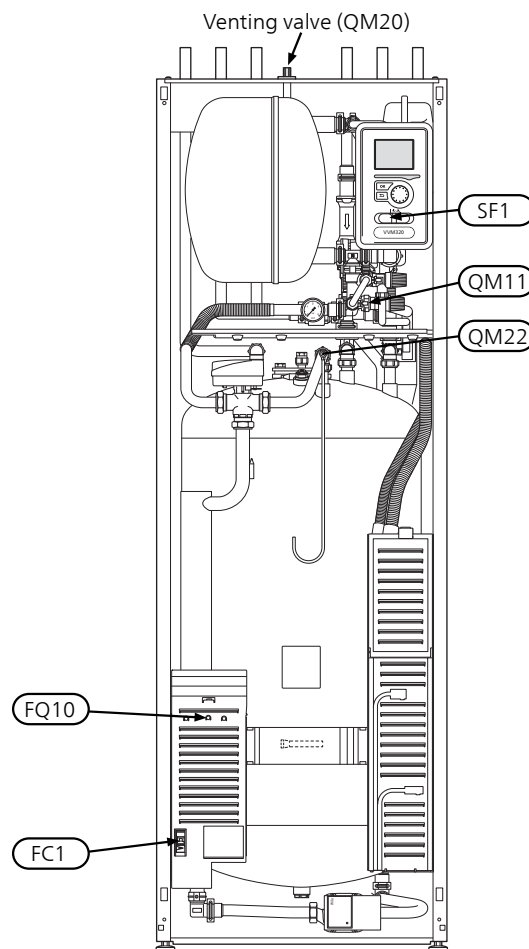

TEMPERATURE SENSOR DATA

Temperature (°C)	Resistance (kOhm)	Voltage (VDC)
-40	351.0	3.256
-35	251.6	3.240
-30	182.5	3.218
-25	133.8	3.189
-20	99.22	3.150
-15	74.32	3.105
-10	56.20	3.047
-5	42.89	2.976
0	33.02	2.889
5	25.61	2.789
10	20.02	2.673
15	15.77	2.541
20	12.51	2.399
25	10.00	2.245
30	8.045	2.083
35	6.514	1.916
40	5.306	1.752
45	4.348	1.587
50	3.583	1.426
55	2.968	1.278
60	2.467	1.136
65	2.068	1.007
70	1.739	0.891
75	1.469	0.785
80	1.246	0.691
85	1.061	0.607
90	0.908	0.533
95	0.779	0.469
100	0.672	0.414

USB SERVICE OUTLET

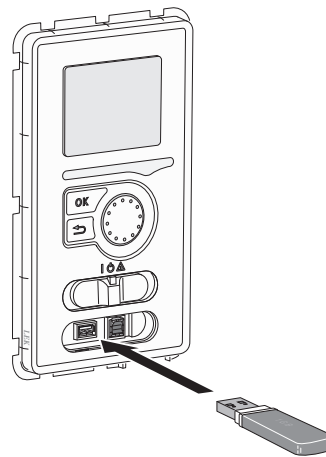

The display unit is equipped with a USB socket that can be used to update the software and save logged information in VVM 320.

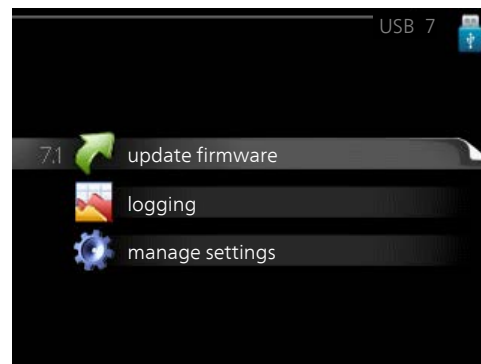
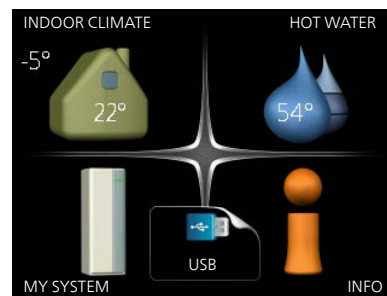

When a USB memory is connected, a new menu (menu 7) appears in the display.

Menu 7.1 - update firmware

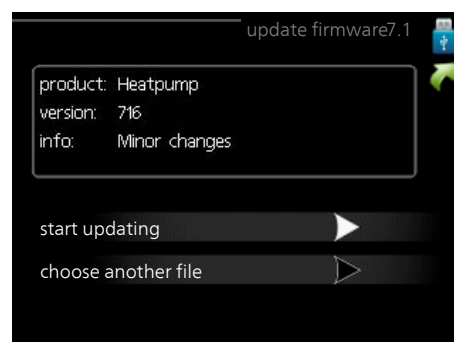

This allows you to update the software in VVM 320.



NOTE

For the following functions to work the USB memory must contain files with software for VVM 320 from NIBE.

The fact box at the top of the display shows information (always in English) of the most probable update that the update software has selected from the USB memory.

This information states the product for which the software is intended, the software version and general information about it. If you want a file other than the one selected, the correct file can be selected through "choose another file".

start updating

Select "start updating" if you want to start the update. You are asked whether you really want to update the software. Respond "yes" to continue or "no" to undo.

If you responded "yes" to the previous question the update starts and you can now follow the progress of the update on the display. When the update is complete VVM 320 restarts.



TIP

A software update does not reset the menu settings in VVM 320.



Caution

If the update is interrupted before it is complete (for example power cut etc.), the software can be reset to the previous version if the OK button is held in during start up until the green lamp starts to illuminate (takes about 10 seconds).

choose another file

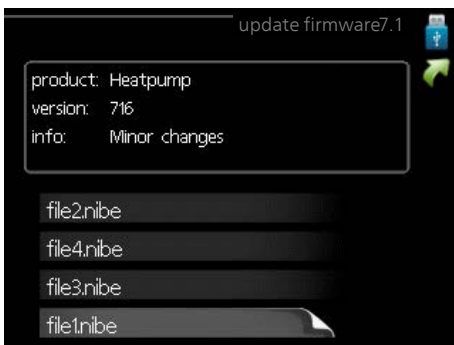

Select "choose another file" if you do not want to use the suggested software. When you scroll through the files, information about the marked software is shown in a fact box just as before. When you have selected a file with the OK button you will return to the previous page (menu 7.1) where you can choose to start the update.

Menu 7.2 - logging

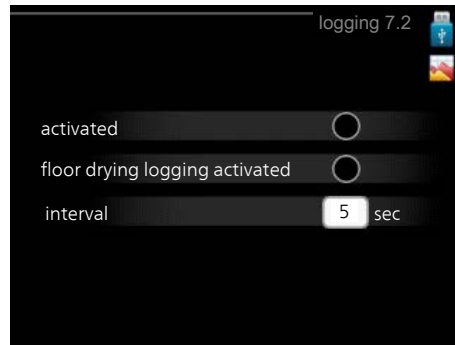

Setting range: 1 s – 60 min

Factory setting range: 5 s

Here you can choose how current measurement values from VVM 320 should be saved onto a log file on the USB memory.

1. Set the desired interval between loggings.
2. Tick "activated".
3. The present values from VVM 320 are saved in a file in the USB memory at the set interval until "activated" is unticked.



Caution

Untick "activated" before removing the USB memory.

Logging floor drying

Here you can save a floor drying log on the USB memory and in this way see when the concrete slab reached the correct temperature.

- Make sure that "floor drying function" is activated in menu 5.9.
- Select "logging floor drying activated".
- A log file is now created, where the temperature and the immersion heater output can be read off. Logging continues until "logging floor drying activated" is deselected or until "floor drying function" is stopped.



Caution

Deselect "logging floor drying activated" before you remove the USB memory.

Menu 7.3 - manage settings

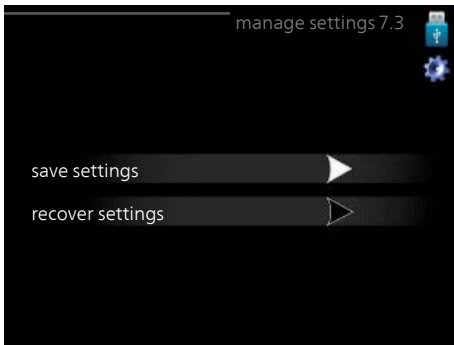

Here you can manage (save as or retrieve from) all the menu settings (user and service menus) in VVM 320 with a USB memory.

Via "save settings" you save the menu settings to the USB memory in order to restore them later or to copy the settings to another VVM 320.



Caution

When you save the menu settings to the USB memory you replace any previously saved settings on the USB memory.

Via "recover settings" you reset all menu settings from the USB memory.



Caution

Reset of the menu settings from the USB memory cannot be undone.

10 Disturbances in comfort

In most cases, VVM 320 notes a malfunction (a malfunction can lead to disruption in comfort) and indicates this with alarms, and instructions for action, in the display.

Info-menu

All the installation's measurement values are gathered under menu 3.1 in the indoor module's menu system. Examining the values in this menu can often make it easier to identify the source of the fault.

Manage alarm

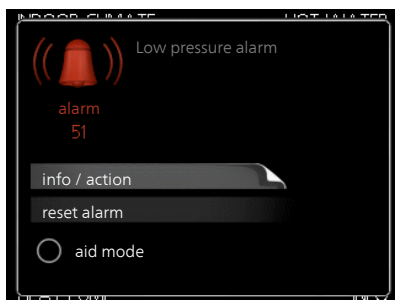

In the event of an alarm, some kind of malfunction has occurred, which is indicated by the status lamp changing from green continuously to red continuously. In addition, an alarm bell appears in the information window.

ALARM

In the event of an alarm with a red status lamp a malfunction has occurred that the indoor module cannot remedy itself. In the display, by turning the control knob and pressing the OK button, you can see the type of alarm it is and reset it. You can also choose to set the indoor module to aid mode.

info / action Here you can read what the alarm means and receive tips on what you can do to correct the problem that caused the alarm.

reset alarm In many cases, it is sufficient to select "reset alarm" for the product to revert to normal operation. If a green light comes on after selecting "reset alarm", the alarm has been remedied. If the red light is still on, and a menu called "alarm" is visible in the display, the problem causing the alarm still remains.

aid mode "aid mode" is a type of emergency mode. This means that the indoor module produces heat and/or hot water, even though there is some kind of problem. This could mean that the heat pump's compressor is not in operation. In this case, the immersion heater produces heat and/or hot water.



Caution

To select aid mode an alarm action must be selected in the menu 5.1.4.



Caution

Selecting "aid mode" is not the same as correcting the problem that caused the alarm. The status lamp will therefore continue to be red.

Troubleshooting

If the operational interference is not shown in the display the following tips can be used:

Basic actions

Start by checking the following items:

- The switch's (SF1) position.
- Group and main fuses of the accommodation.
- The property's earth circuit breaker.
- Miniature circuit breaker for VVM 320 (FC1).
- Temperature limiter for VVM 320 (FQ10).
- Correctly set load monitor.

Low hot water temperature or a lack of hot water

- Closed or choked filling valve for the hot water.
 - Open the valve.
- Mixing valve (if there is one installed) set too low.
 - Adjust the mixer valve.
- VVM 320 in incorrect operating mode.
 - Enter menu 4.2. If mode "auto" is selected, select a higher value on "stop additional heat" in menu 4.9.2.
 - If mode "manual" is selected, select "addition".
 - Hot water is produced with VVM 320 in "manual" mode. If there is no air/water heat pump, "addition" must be activated.
- Large hot water consumption.
 - Wait until the hot water has heated up. Temporarily increased hot water capacity (temporary lux) can be activated in menu 2.1.
- Too low hot water setting.
 - Enter menu 2.2 and select a higher comfort mode.
- Low hot water access with the "Smart Control" function active.
 - If the hot water usage has been low, less hot water than normal will be produced. Restart the product.
- Too low or no operating prioritisation of hot water.
 - Enter menu 4.9.1 and increase the time for when hot water is to be prioritised. Note that, if the time for hot water is increased, the time for heating production is reduced, which can give lower/uneven room temperatures.
- "Holiday mode" activated in menu 4.7.
 - Enter menu 4.7 and select "Off".

Low room temperature

- Closed thermostats in several rooms.
 - Set the thermostats to max, in as many rooms as possible. Adjust the room temperature via menu 1.1, instead of choking the thermostats.
 - See the "Saving tips" section in the User manual for more detailed information about how to best set the thermostats.
- VVM 320 in incorrect operating mode.
 - Enter menu 4.2. If mode "auto" is selected, select a higher value on "stop heating" in menu 4.9.2.
 - If mode "manual" is selected, select "heating". If this is not enough, select "addition".
- Too low set value on the automatic heating control.

- Enter menu 1.1 "temperature" and adjust the offset heating curve up. If the room temperature is only low in cold weather the curve slope in menu 1.9.1 "heating curve" needs adjusting up.
- Too low or no operating prioritisation of heat.
 - Enter menu 4.9.1 and increase the time for when heating is to be prioritised. Note that if the time for heating is increased the time for hot water production is reduced, which can give smaller amounts of hot water.
- "Holiday mode" activated in menu 4.7.
 - Enter menu 4.7 and select "Off".
- External switch for changing room temperature activated.
 - Check any external switches.
- Air in the climate system.
 - Vent the climate system (see page 34).
- Closed valves to the climate system.
 - Closed valves to the climate system or heat pump.
 - Open the valves.

High room temperature

- Too high set value on the automatic heating control.
 - Enter menu 1.1 (temperature) and reduce the offset heating curve. If the room temperature is only high in cold weather the curve slope in menu 1.9.1 "heating curve" needs adjusting down.
- External switch for changing room temperature activated.
 - Check any external switches.

Low system pressure

- Not enough water in the climate system.
 - Fill the climate system with water and check for leaks (see page 34).

The air/water heat pump's compressor does not start

- There is no heating or cooling demand (accessory is required for cooling).
 - VVM 320 does not call on heating, cooling or hot water.
- Compressor blocked due to the temperature conditions.
 - Wait until the temperature is within the product's working range.
- Minimum time between compressor starts has not been reached.
 - Wait for at least 30 minutes and then check if the compressor has started.
- Alarm tripped.
 - VVM 320 temporarily blocked, see menu 3.2 "Compressor information".

Electrical addition only

If you are unsuccessful in rectifying the fault and are unable to heat the house, you can, whilst waiting for assistance, continue running the heat pump in "add. heat only". This means that additional heating only is used to heat the house.

SET THE INSTALLATION TO ADDITIONAL HEAT MODE

1. Go to menu 4.2 op. mode.
2. Mark "add. heat only" using the control knob and then press the OK button.
3. Return to the main menus by pressing the Back button.

11 Accessories

Detailed information about the accessories and complete accessories list available at nibe.eu.

Not all accessories are available on all markets.

ACCESSORY CARD AXC 40

An accessory card is required if step controlled addition (e.g. external electric boiler) or if shunt controlled addition (e.g. wood/oil/gas/pellet boiler) is to be connected to VVM 320.

An accessory card is also required if for example an external circulation pump is connected to VVM 320 at the same time that the buzzer alarm is activated.

Part no. 067 060

ACTIVE COOLING ACS 310*

ACS 310 is an accessory that enables VVM 320 to control the production of cooling.

Part no. 067 248

*The accessory requires that NIBE air/water heat pump is installed.

AUXILIARY RELAY HR 10

Auxiliary relay HR 10 is used to control external 1 to 3 phase loads such as oil burners, immersion heaters and pumps.

Part no 067 309

BASE EXTENSION EF 45

This accessory is used to create a larger connection area under VVM 320.

Part no. 067 152

BUFFER VESSEL UKV

A buffer vessel is an accumulator tank that is suitable for connection to a heat pump or another external heat source, and can have several different applications. It can also be used during external control of the heating system.

UKV 40

Part no. 088 470

UKV 100

Part no. 088 207

UKV 200 Cooling

Part no. 080 321

UKV 300 Cooling

Part no. 080 330

COMMUNICATION MODULE FOR SOLAR ELECTRICITY EME 20

EME 20 is used to enable communication and control between inverters for solar cells from NIBE and VVM 320.

Part no. 057 188

COMMUNICATIONS MODULE MODBUS 40

MODBUS 40 enables VVM 320 to be controlled and monitored using a DUC (computer sub-centre) in the building. Communication is then performed using MODBUS-RTU.

Part no 067 144

COMMUNICATIONS MODULE SMS 40

When there is no internet connection, you can use the accessory SMS 40 to control VVM 320 via SMS.

Part no 067 073

ENERGY MEASUREMENT KIT EMK 300

This accessory is installed externally and used to measure the amount of energy that is supplied for the pool, hot water, heating and cooling in the building.

Part no. 067 314

EXHAUST AIR HEAT PUMP F135*

F135 is an exhaust air heat pump specially designed to combine the recovery of mechanical exhaust air with air/water heat pump. Indoor module/control module controls F135.

Part no. 066 075

*The accessory requires that NIBE air/water heat pump is installed.

EXTERNAL ELECTRIC ADDITIONAL HEAT ELK

ELK 15

15 kW, 3x400V
Part no. 069 022

ELK 213

7–13 kW, 3x400V
Part no. 069 500

EXTRA SHUNT GROUP ECS 40/ECS 41

This accessory is used when VVM 320 is installed in houses with two or more different heating systems that require different supply temperatures.

ECS 40 (Max 80 m²) *ECS 41 (approx.*

Part no 067 287

80-250 m²)

Part no 067 288

HRV UNIT ERS

This accessory is used to supply the accommodation with energy that has been recovered from the ventilation air. The unit ventilates the house and heats the supply air as necessary.

ERS 10-400

ERS 20-250

Part no. 066 115

Part no. 066 068

This accessory is used to supply the dwelling with energy that has been recovered from the ventilation air. The unit ventilates the house and heats the supply air as necessary. ERS 30 has been specifically designed for use in attics and other cool spaces.

ERS 30-400

Part no. 066 165

HUMIDITY SENSOR HTS 40

This accessory is used to show and regulate humidity and temperatures during both heating and cooling operation.

Part no. 067 538

MEASUREMENT KIT FOR SOLAR GENERATED ELECTRICITY EME 10

EME 10 is used to optimise the use of solar generated electricity. EME 10 measures the relevant current from the inverter via a current transformer and can work with all inverters.

Part no. 067 541

POOL HEATING POOL 310*

POOL 310 is an accessory that enables pool heating with VVM 320.

Part no. 067 247

*The accessory requires that NIBE air/water heat pump is installed.

ROOM UNIT RMU 40

The room unit is an accessory that allows the control and monitoring of VVM 320 to be carried out in a different part of your home to where it is located.

Part no 067 064

SOLAR PACKAGE NIBE PV

Solar panel package, 3.2 – 22.4 kW (10 – 80 panels), which is used to produce your own electricity.

TOP CABINET TOC 30

Top cabinet, which conceals any pipes/ventilation ducts.

Height 245 mm

Height 345 mm

Part no. 067 517

Part no. 067 518

Height 385-635 mm

Part no. 067 519

12 Technical data

Dimensions and setting-out coordinates

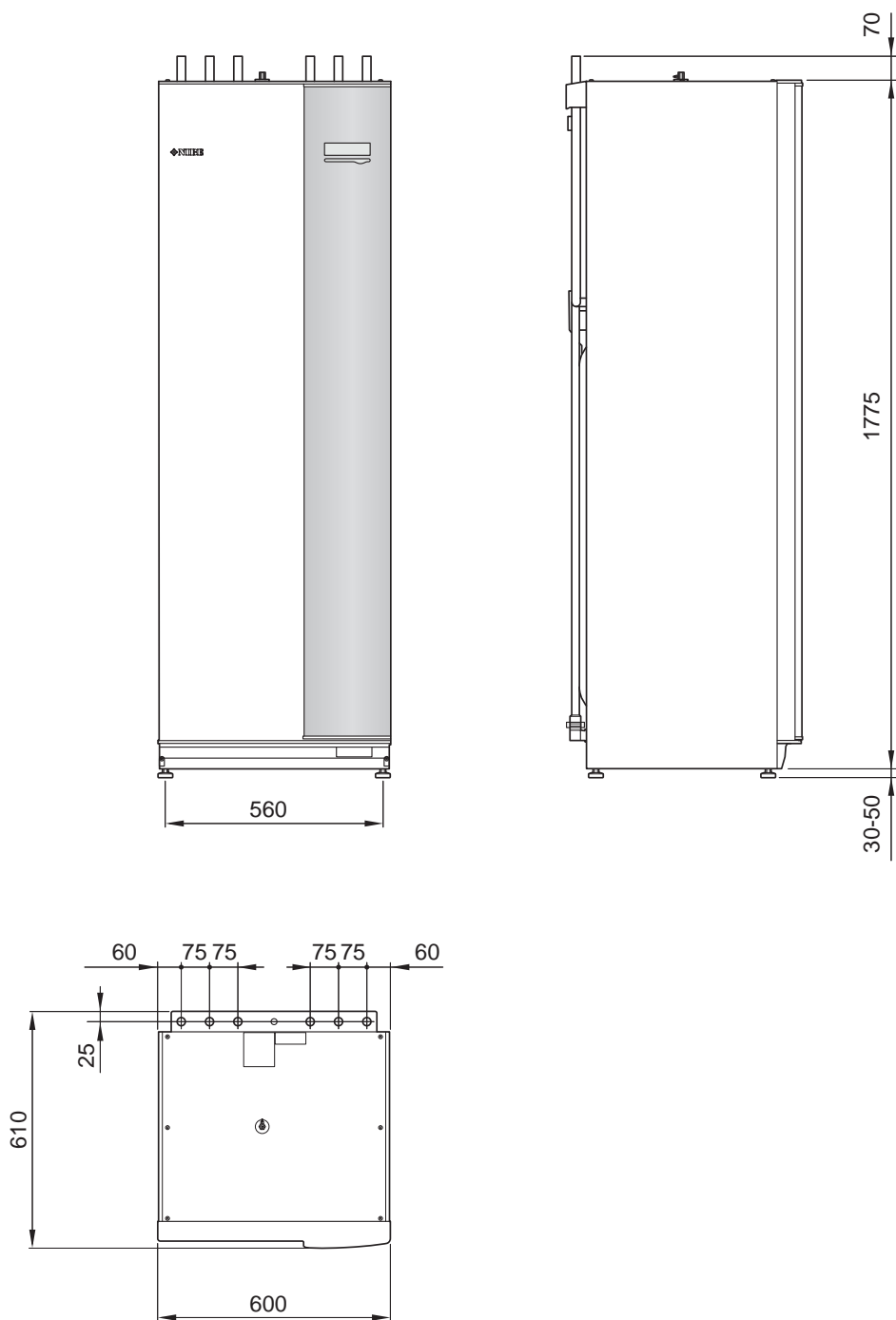

Technical specifications

3X400V

<i>3x400V</i>		
<i>Compatible NIBE air/water heat pumps</i>		
F2040		6 / 8 / 12
F2120		8 / 12 / 16
NIBE SPLIT HBS 05 (AMS 10 + HBS 05-6 / HBS 05-12)		6 / 8 / 12
<i>Electrical data</i>		
Additional power	kW	9
Rated voltage		400V 3N~50Hz
Max operating current	A	16
Fuse	A	16
Output, GP1	W	3 – 76
Output, GP6	W	3 – 45
Enclosure class		IP21
<i>Heating medium circuit</i>		
Energy class, GP1		low energy
Energy class, GP6		low energy
Max system pressure heating medium	MPa	0.3 (3 bar)
Max HM temp	°C	70
<i>Pipe connections</i>		
Heating medium	mm	Ø22
Hot water connection	mm	Ø22
Cold water connection	mm	Ø22
Heat pump connections	mm	Ø22
<i>Miscellaneous</i>		
<i>Indoor module</i>		
Volume, hot water heater	l	180
Volume, total indoor module	l	206
Volume buffer vessel	l	26
Max. permitted pressure, water heater	MPa (bar)	1.0 (10 bar)
Cut-off pressure, hot water heater	MPa (bar)	0.9 (9 bar)
Max permitted pressure in indoor module	MPa (bar)	0.3 (3 bar)
Cut-off pressure, indoor module	MPa (bar)	0.25 (2.5 bar)
<i>Capacity, hot water heating According to EN16147</i>		
Tap volume 40°C at Economy comfort	l	210
Tap volume 40 °C during Normal comfort	l	240
Tap volume 40 °C during Lux comfort	l	280
<i>Dimensions and weight</i>		
Width	mm	600
Depth	mm	615
Height (without base)	mm	1,800
Height (with base)	mm	1,830 – 1,850
Required ceiling height	mm	1,910
Weight (excl. packaging and without water)	kg	146
Substances according to Directive (EG) no. 1907/2006, article 33 (Reach)		Lead in brass components
Part number Copper - VVM 320 CU		069 108
Part number Stainless steel - VVM 320 R		069 109
Part number Enamel – VVM 320 E EM		069 203

3X230V

<i>3x230V</i>		
<i>Compatible NIBE air/water heat pumps</i>		
F2040		6 / 8 / 12
F2120		8 / 12 / 16
NIBE SPLIT HBS 05 (AMS 10 + HBS 05-6 / HBS 05-12)		6 / 8 / 12
<i>Electrical data</i>		
Additional power	kW	9
Rated voltage		230V 3N~50Hz
Max operating current	A	27.5
Fuse	A	32
Output, GP1	W	3 – 76
Output, GP6	W	3 – 45
Enclosure class		IP21
<i>Heating medium circuit</i>		
Energy class, GP1		low energy
Energy class, GP6		low energy
Max system pressure heating medium	MPa	0.3 (3 bar)
Max HM temp	°C	70
<i>Pipe connections</i>		
Heating medium		Ø22
Hot water connection		Ø22
Cold water connection		Ø22
Heat pump connections		Ø22
<i>Other, indoor module</i>		
Volume, hot water heater	l	180
Volume, total indoor module	l	206
Volume buffer vessel	l	26
Max. permitted pressure, water heater	MPa (bar)	1.0 (10 bar)
Cut-off pressure, hot water heater	MPa (bar)	1.0 (10 bar)
Max permitted pressure in indoor module	MPa (bar)	0.3 (3 bar)
Cut-off pressure, indoor module	MPa (bar)	0.25 (2.5 bar)
<i>Capacity, hot water heating according to EN16147</i>		
Tap volume 40°C at Economy comfort	l	210
Tap volume 40 °C during Normal comfort	l	240
Tap volume 40 °C during Lux comfort	l	280
<i>Dimensions and weight</i>		
Width	mm	600
Depth	mm	615
Height (without base)	mm	1,800
Height (with base)	mm	1,830 – 1,850
Required ceiling height	mm	1,910
Weight (excl. packaging and without water)	kg	146
Substances according to Directive (EG) no. 1907/2006, article 33 (Reach)		Lead in brass components
Part number Stainless steel - VVM 320 3x230V R		069 113

1X230V

1x230V		
<i>Compatible NIBE air/water heat pumps</i>		
F2040		6 / 8 / 12
F2120		8 / 12 / 16
NIBE SPLIT HBS 05 (AMS 10 + HBS 05-6 / HBS 05-12)		6 / 8 / 12
<i>Electrical data</i>		
Additional power	kW	7
Rated voltage		230V~50Hz
Max operating current	A	32
Fuse	A	32
Output, GP1	W	3 – 76
Output, GP6	W	3 – 45
Enclosure class		IP21
<i>Heating medium circuit</i>		
Energy class, GP1		low energy
Energy class, GP6		low energy
Max system pressure heating medium	MPa	0.3 (3 bar)
Max HM temp	°C	70
<i>Pipe connections</i>		
Heating medium		Ø22
Hot water connection		Ø22
Cold water connection		Ø22
Heat pump connections		Ø22
<i>Other, indoor module</i>		
Volume, hot water heater	l	180
Volume, total indoor module	l	206
Volume buffer vessel	l	26
Max. permitted pressure, water heater	MPa (bar)	1.0 (10 bar)
Cut-off pressure, hot water heater	MPa (bar)	0.9 (9 bar)
Max permitted pressure in indoor module	MPa (bar)	0.3 (3 bar)
Cut-off pressure, indoor module	MPa (bar)	0.25 (2.5 bar)
<i>Capacity, hot water heating according to EN16147</i>		
Tap volume 40°C at Economy comfort	l	210
Tap volume 40 °C during Normal comfort	l	240
Tap volume 40 °C during Lux comfort	l	280
<i>Dimensions and weight</i>		
Width	mm	600
Depth	mm	615
Height (without base)	mm	1,800
Height (with base)	mm	1,830 – 1,850
Required ceiling height	mm	1,910
Weight (excl. packaging and without water)	kg	146
Substances according to Directive (EG) no. 1907/2006, article 33 (Reach)		Lead in brass components
Part number Stainless steel - VVM 320 1x230V R		069 111

Electrical circuit diagram

3X400V

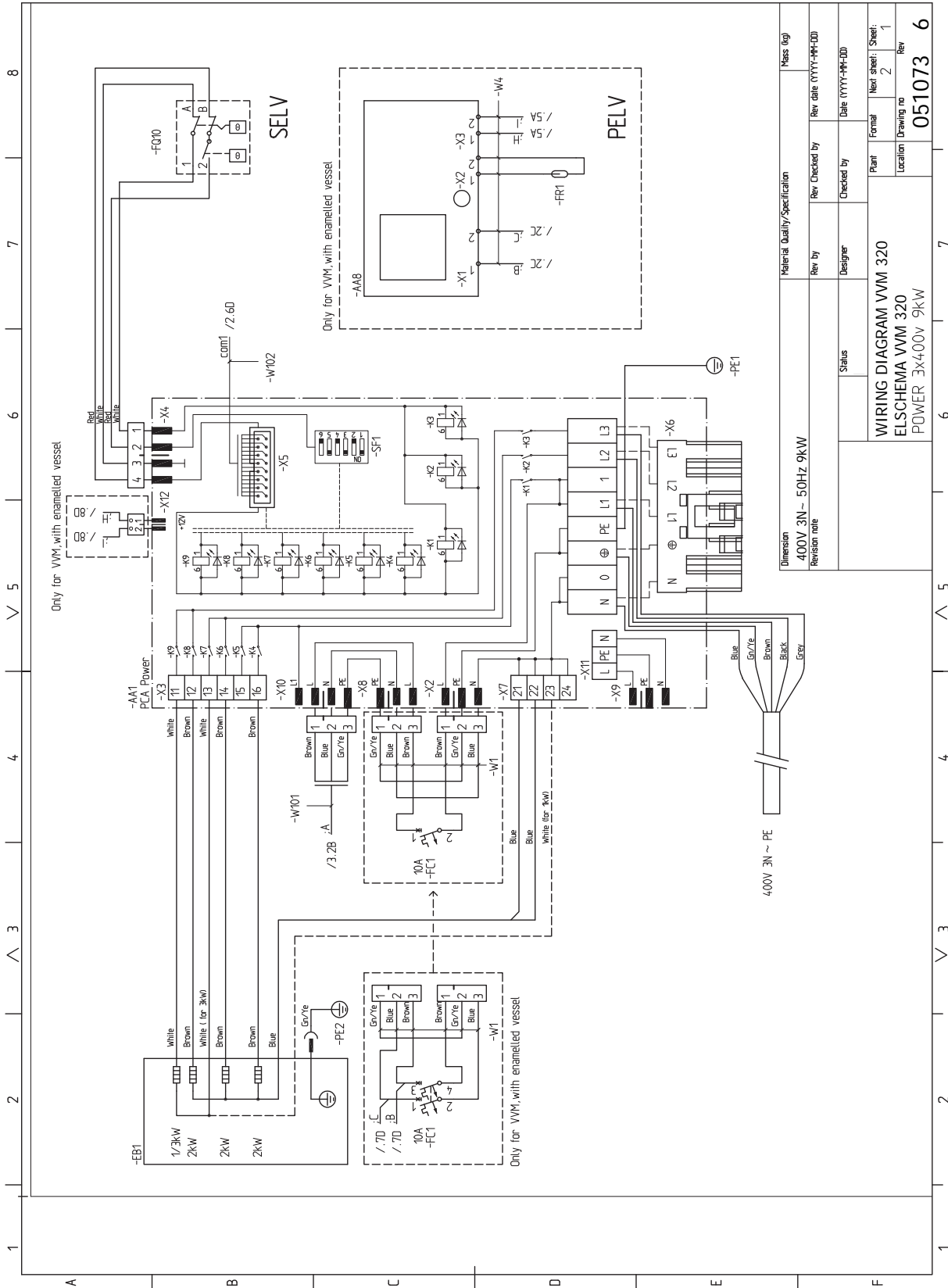

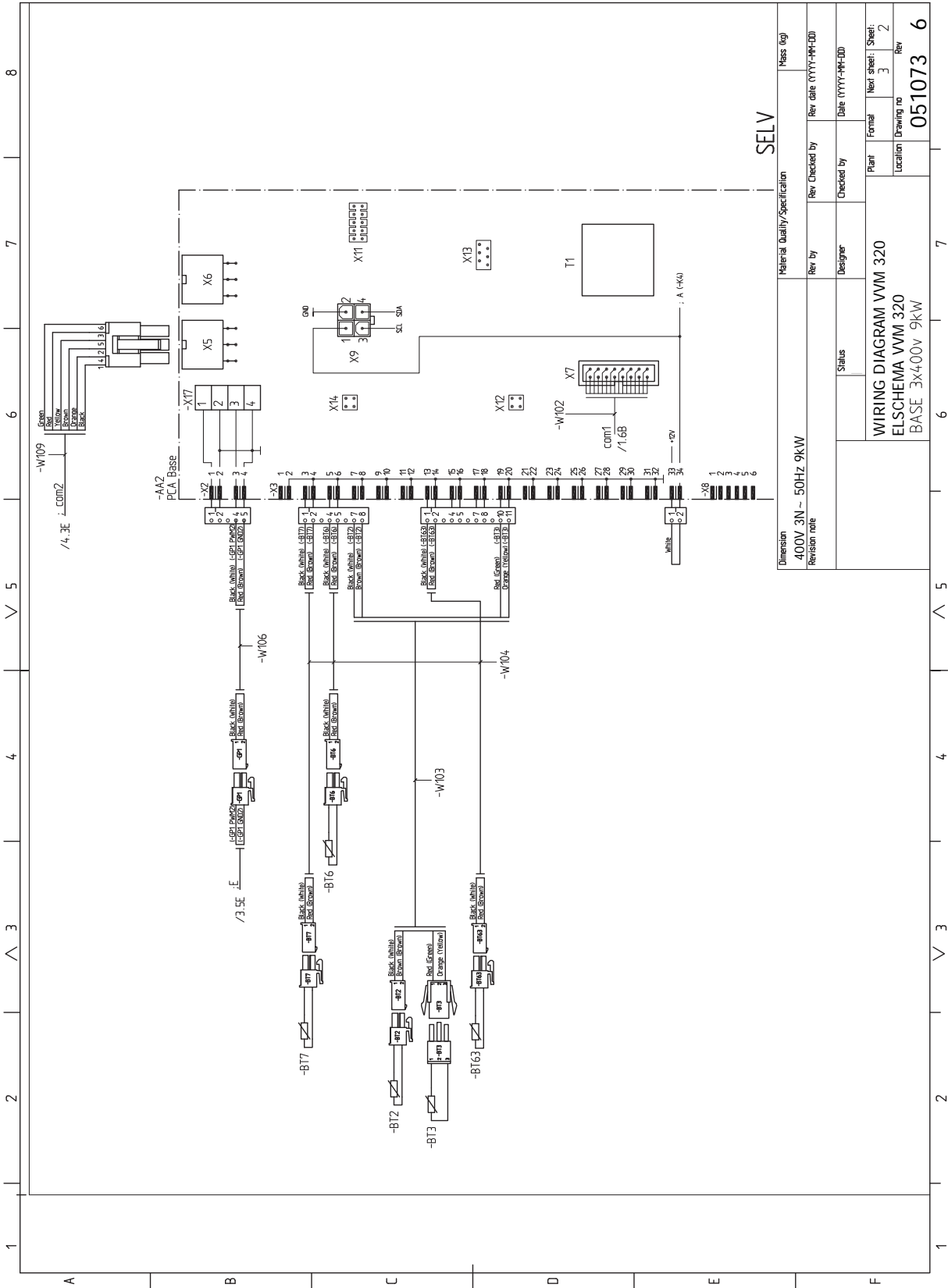

SELV

Material Quality/Specification	Mass (kg)	
Dimension	400V 3N - 50Hz 9kW	Rev by
Revision note		Checked by
	Status	Designer
	WIRING DIAGRAM VVM 320	Plant
	ELSHEMA VVM 320	Location
	BASE 3x400v 9kW	Formal
		Next sheet: Sheet: 2
		Drawing no
		Rev
		051073
		6

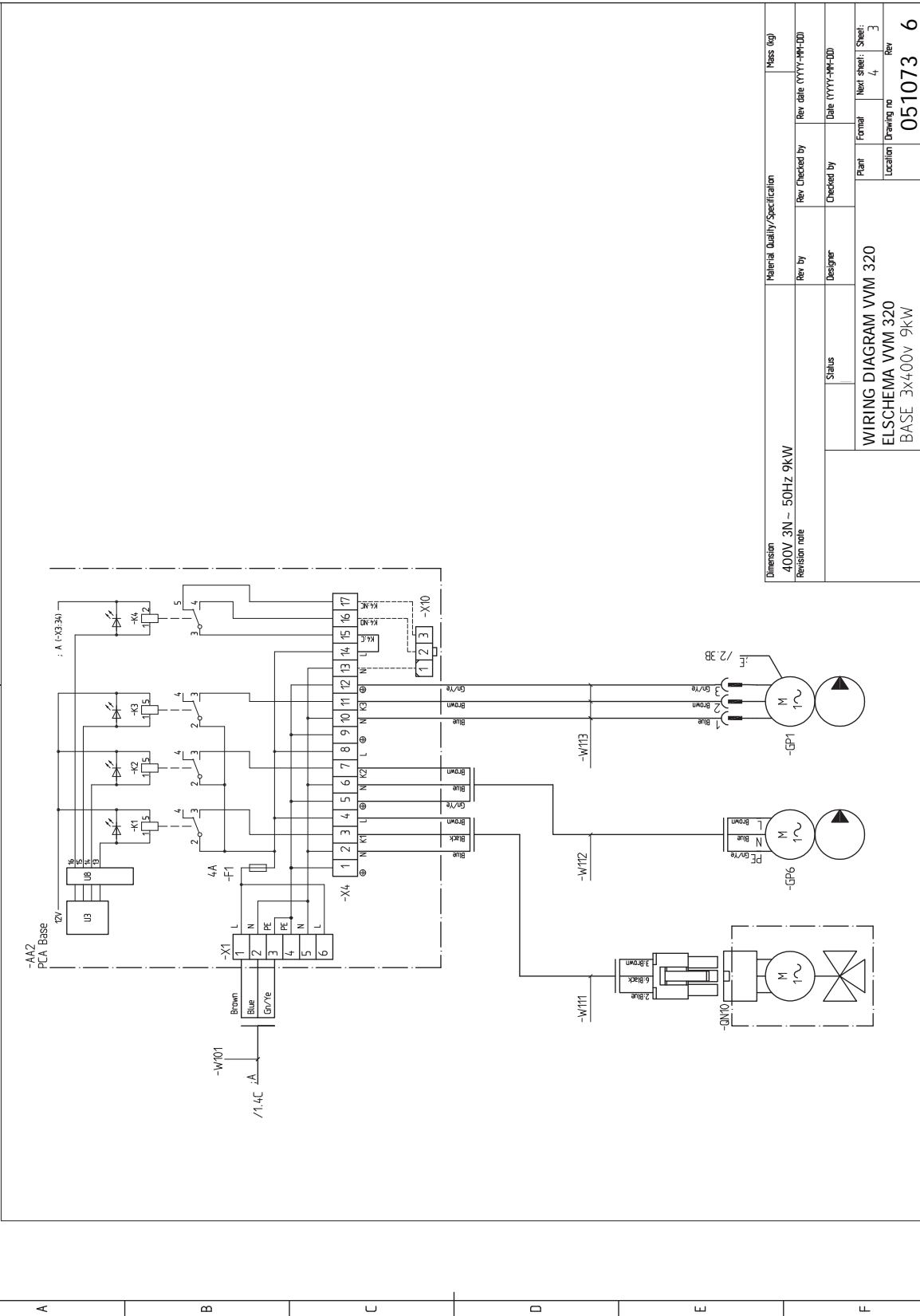

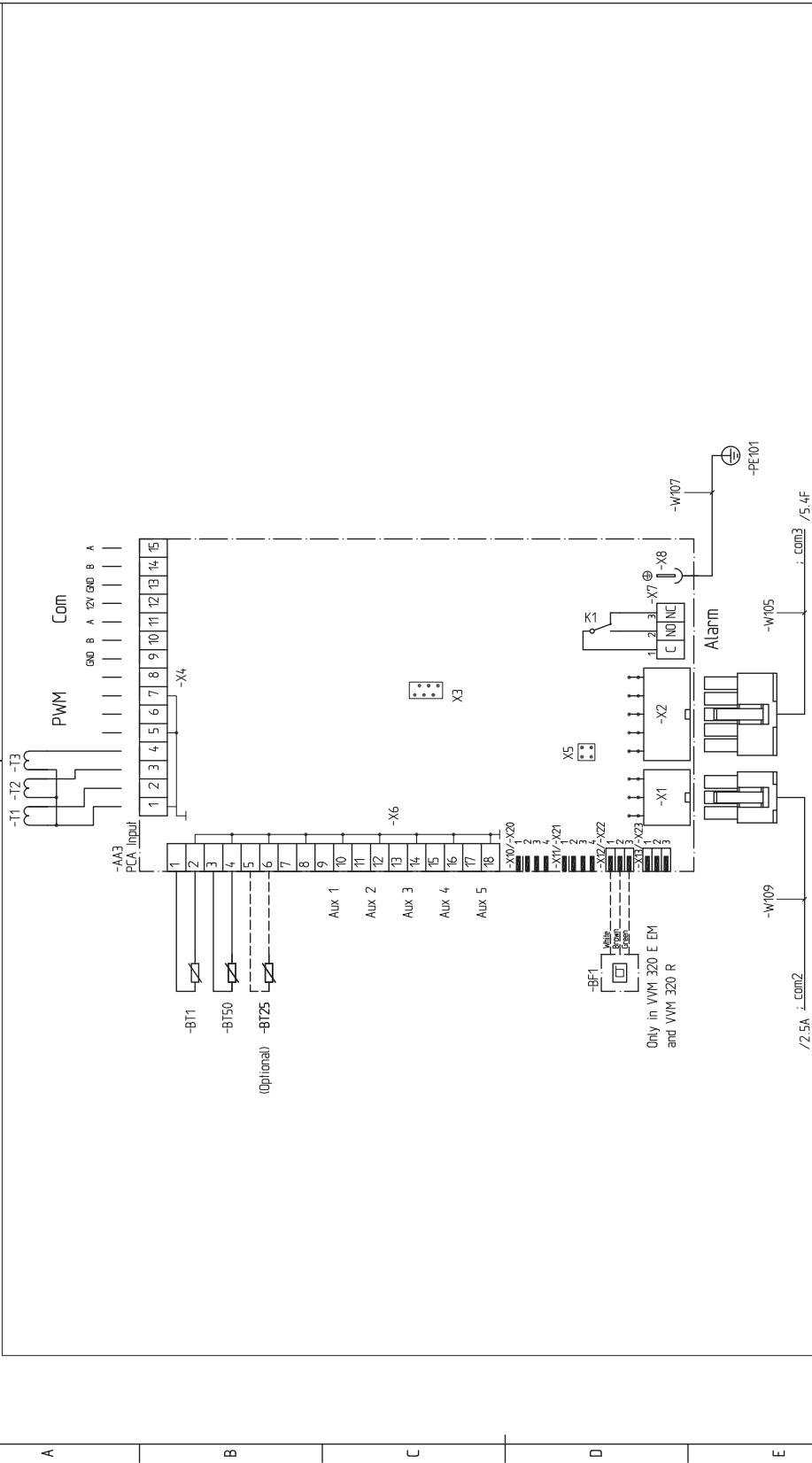

SELV

Dimension	Material Quality/Specification			Mass (kg)
400V 3N - 50Hz 9kW	Rev by	Rev Checked by	Rev Table (YYYY-MM-DD)	
Revision note	Designer	Checked by	Date (YYYY-MM-DD)	
	Status			
	Plant			Formal
	WIRING DIAGRAM VWM 320			Next sheet: 5
	ELSCHEMA VWM 320			Sheet: 4
	INPUT 3x400V 9kW			Drawing no
				Rev
				051073
				6

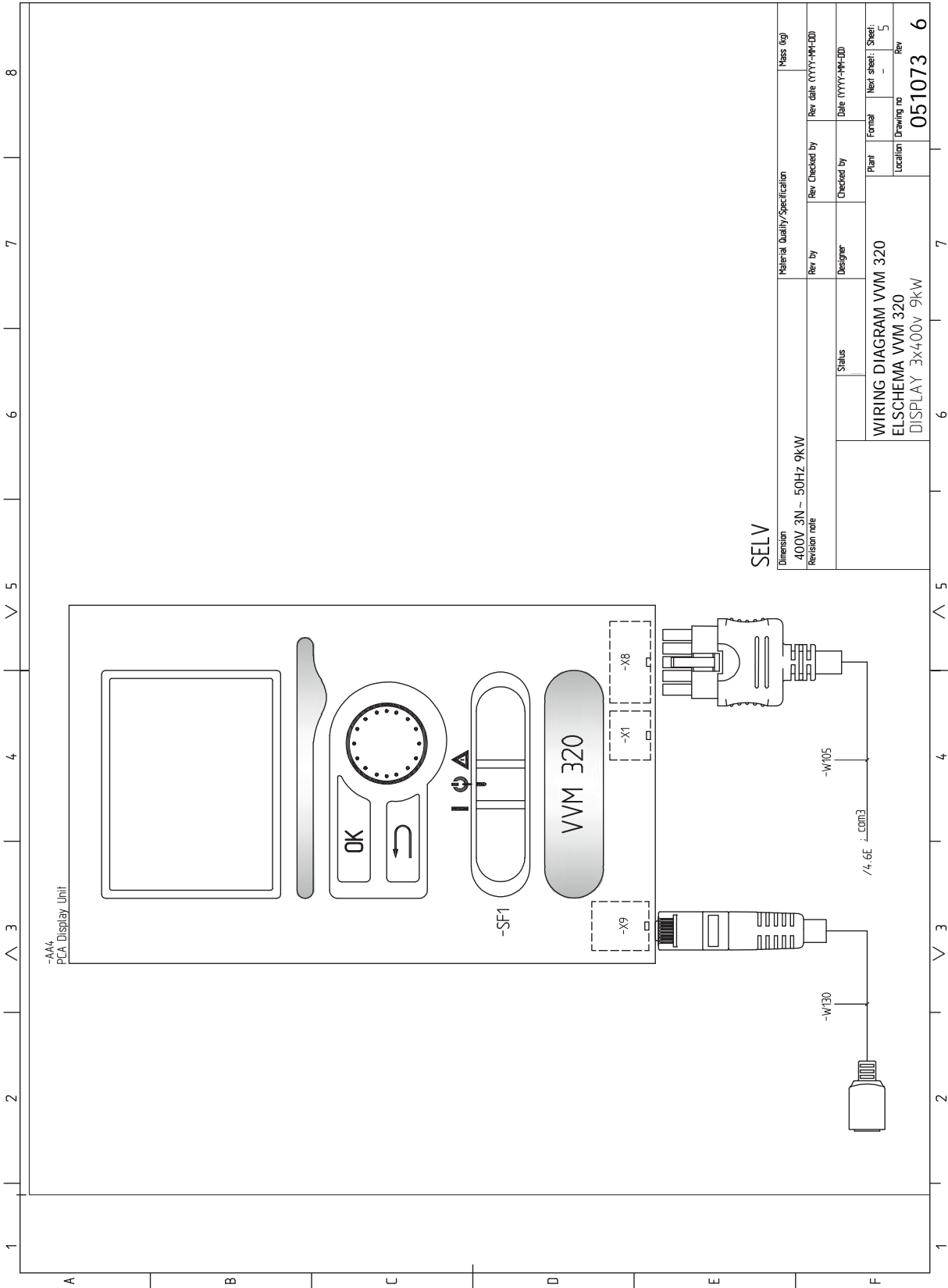

SELV

Dimension	Material Quality/Specification		Mass (kg)
400V 3N - 50Hz 9kW	Rev By	Rev Checked by	Rev table (YYYY-MM-DD)
Revision note	Designer	Checked by	Date (YYYY-MM-DD)
	Status	Plant	Formal
		Location	Next sheet
			Drawing no
			Rev
			051073
			6

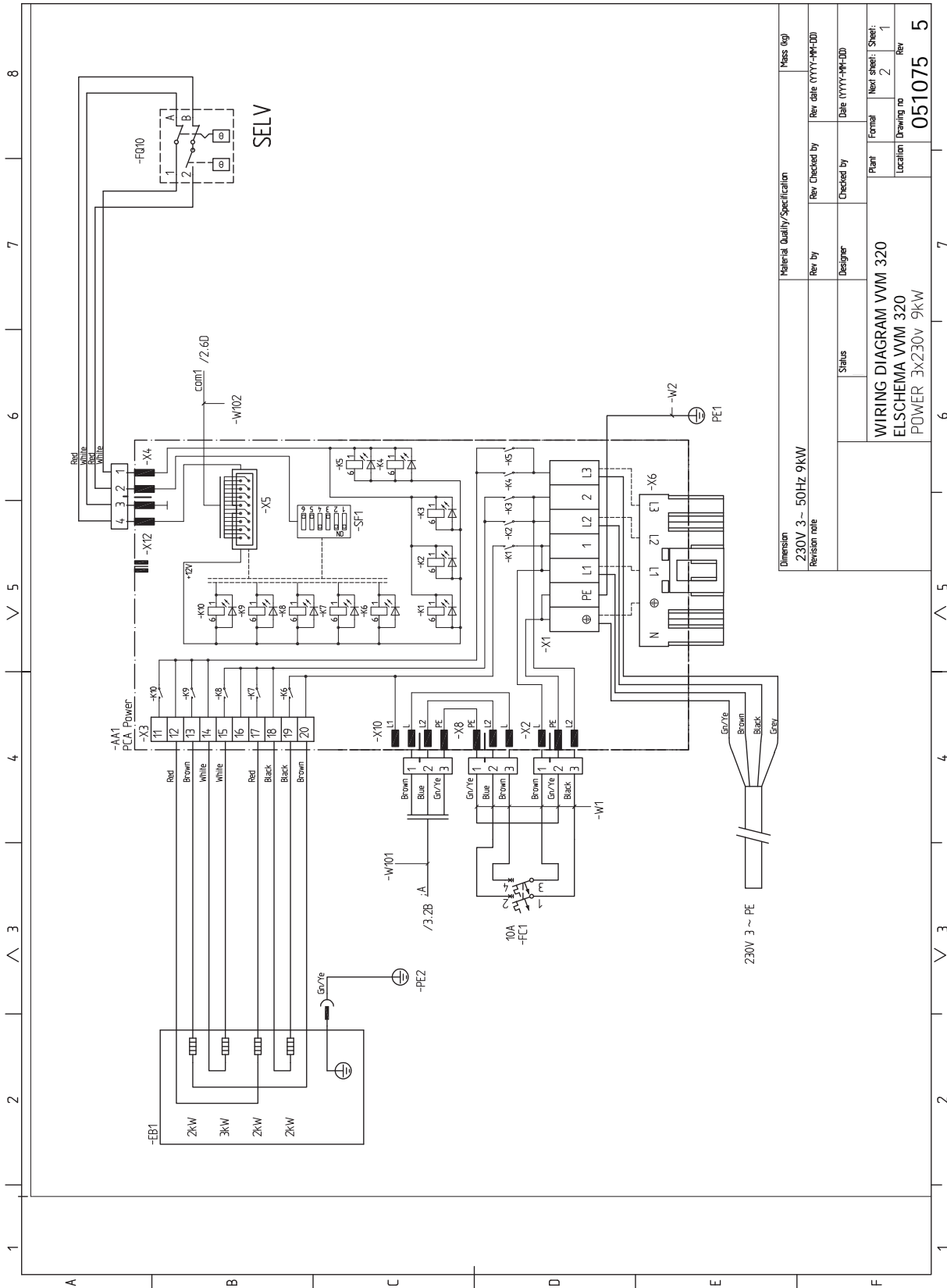

Dimension	Material Quality/Specification		Mass (kg)
230V 3~ 50Hz 9kW	Rev by	Rev Checked by	Rev date (YYYY-MM-DD)
Revision note	Designer	Checked by	Date (YYYY-MM-DD)
	Status	Plant	New sheet: 2
		Location	Sheet: 1
		Drawing no	Rev
			051075
			5

WIRING DIAGRAM VVM 320
 ELSHEMA VVM 320
 POWER 3x230v 9kW

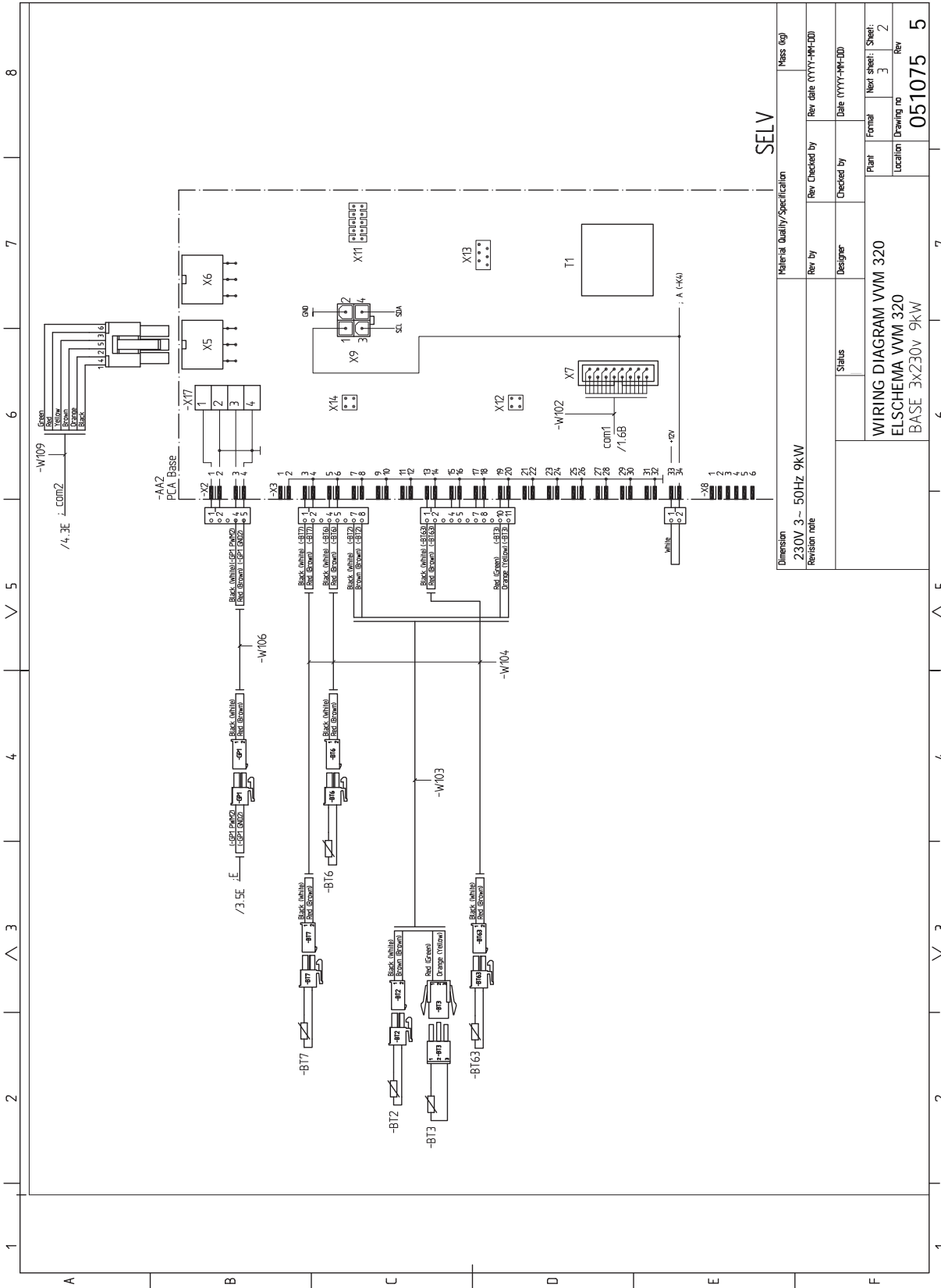

SELV

Dimension	Material Quality/Specification		Mass (kg)
230V 3~ 50Hz 9kW	Rev by	Rev Checked by	Rev label (YYYY-MM-DD)
Revision note	Designer	Checked by	Date (YYYY-MM-DD)
	Status		
	Plant	Formal	Next sheet Sheet:
	Location	Drawing no	3 2
		Rev	Rev
			051075 5

WIRING DIAGRAM VVM 320
 ELSCHHEMA VVM 320
 BASE 3x230v 9kW

1 2 3 4 5 6 7 8

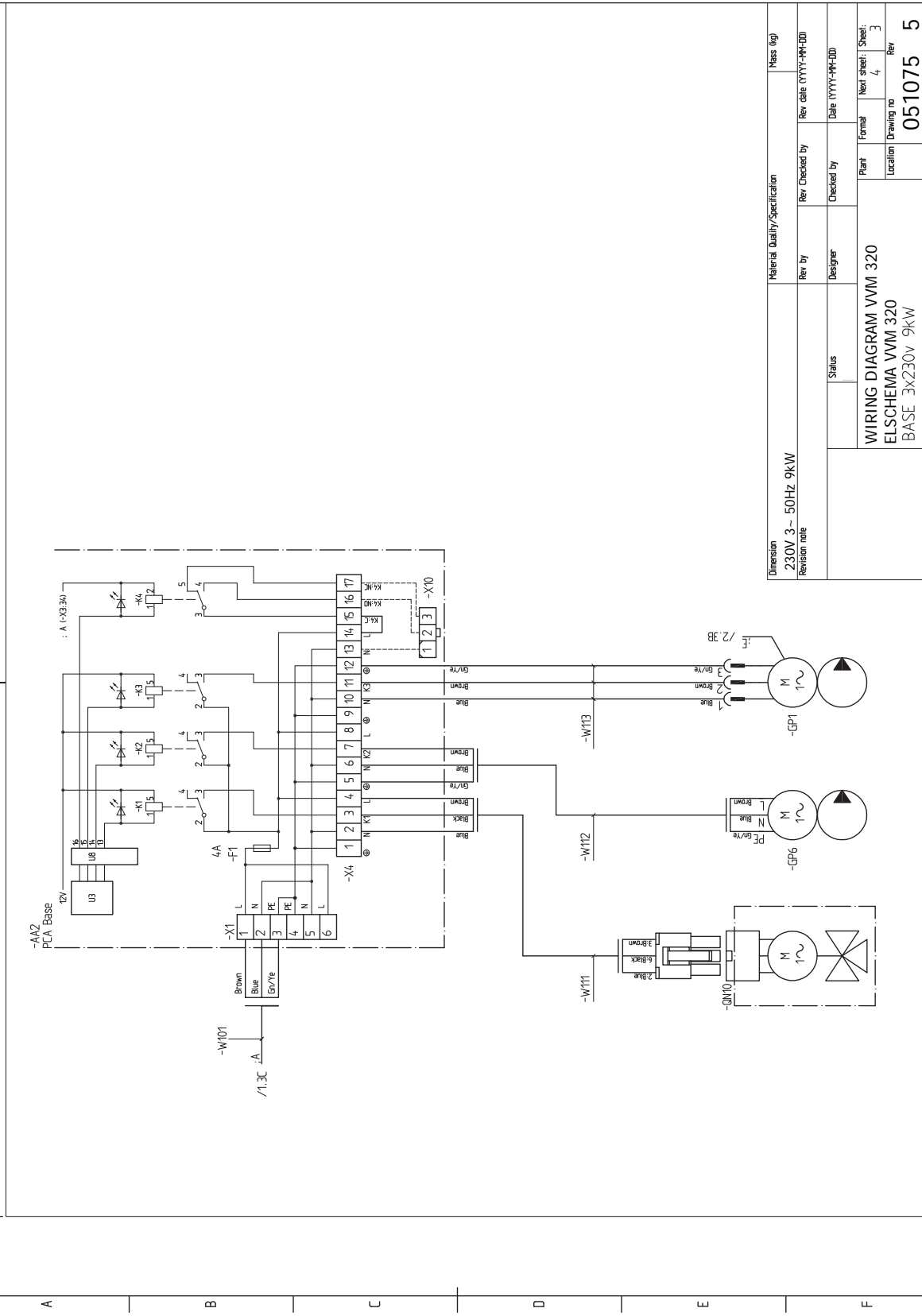

1 2 3 4 5 6 7 8

A B C D E F

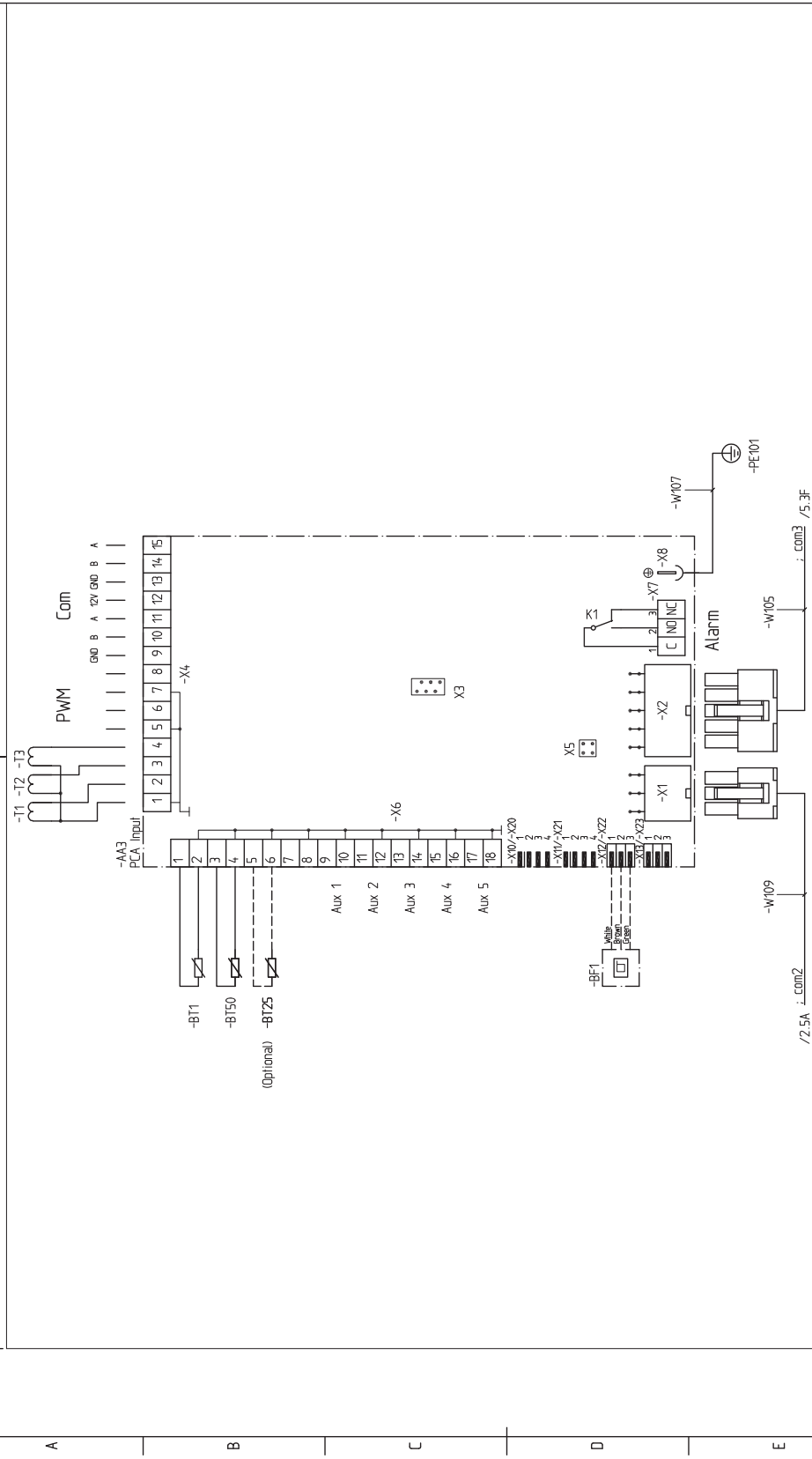

SELV

Dimension		Material Quality/Specification		Mass (kg)	
230V 3~ 50Hz 9kW					
Revision note		Rev by	Rev Checked by	Rev table (YYYY-MM-DD)	Rev
		Designer	Checked by	Date (YYYY-MM-DD)	Sheet
		Status		Plant	5
				Location	4
				Formal Drawing no	051075
				Rev	5

WIRING DIAGRAM VWM 320
 ELSCHHEMA VWM 320
 INPUT 3x230v 9kW

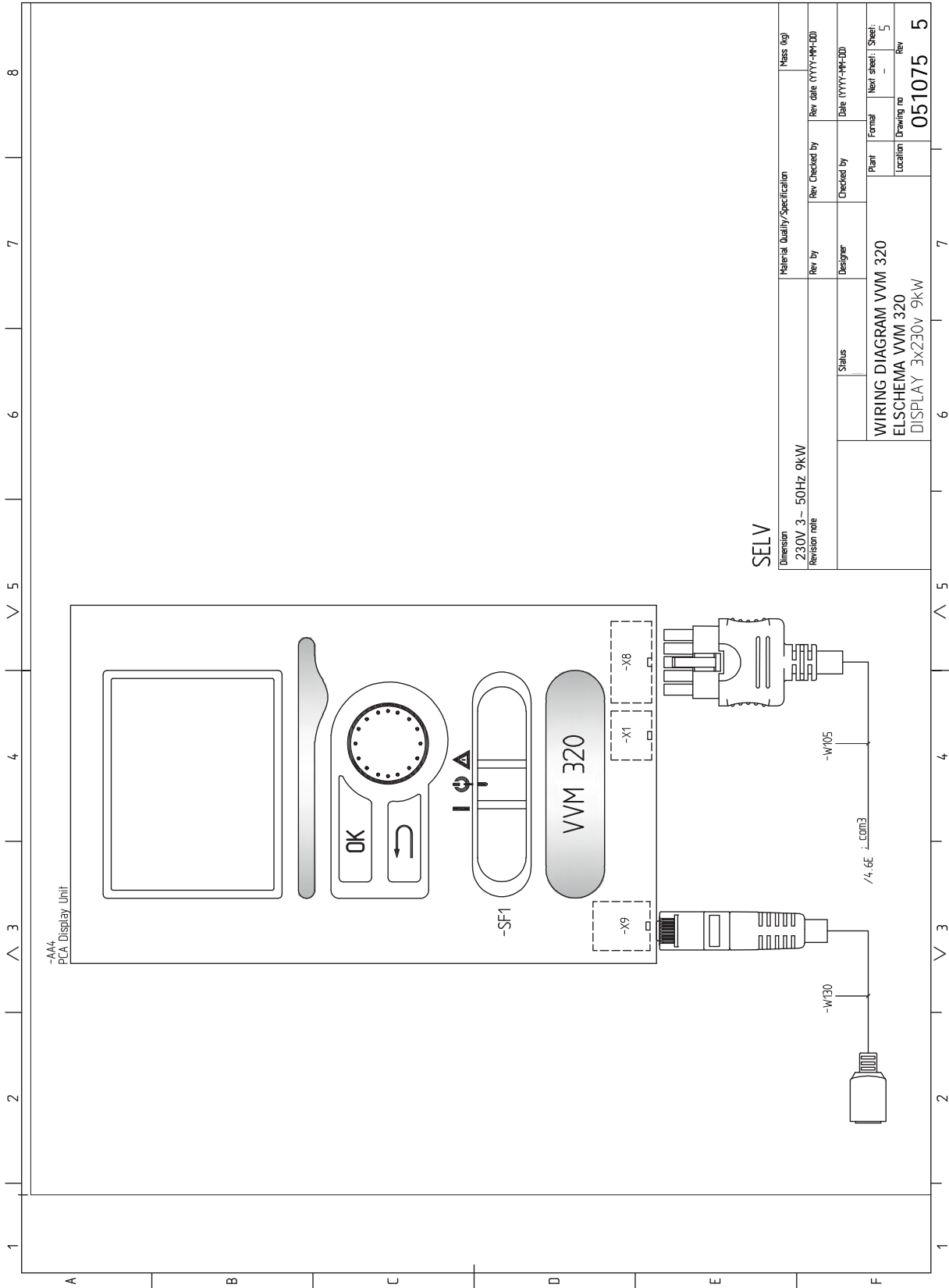

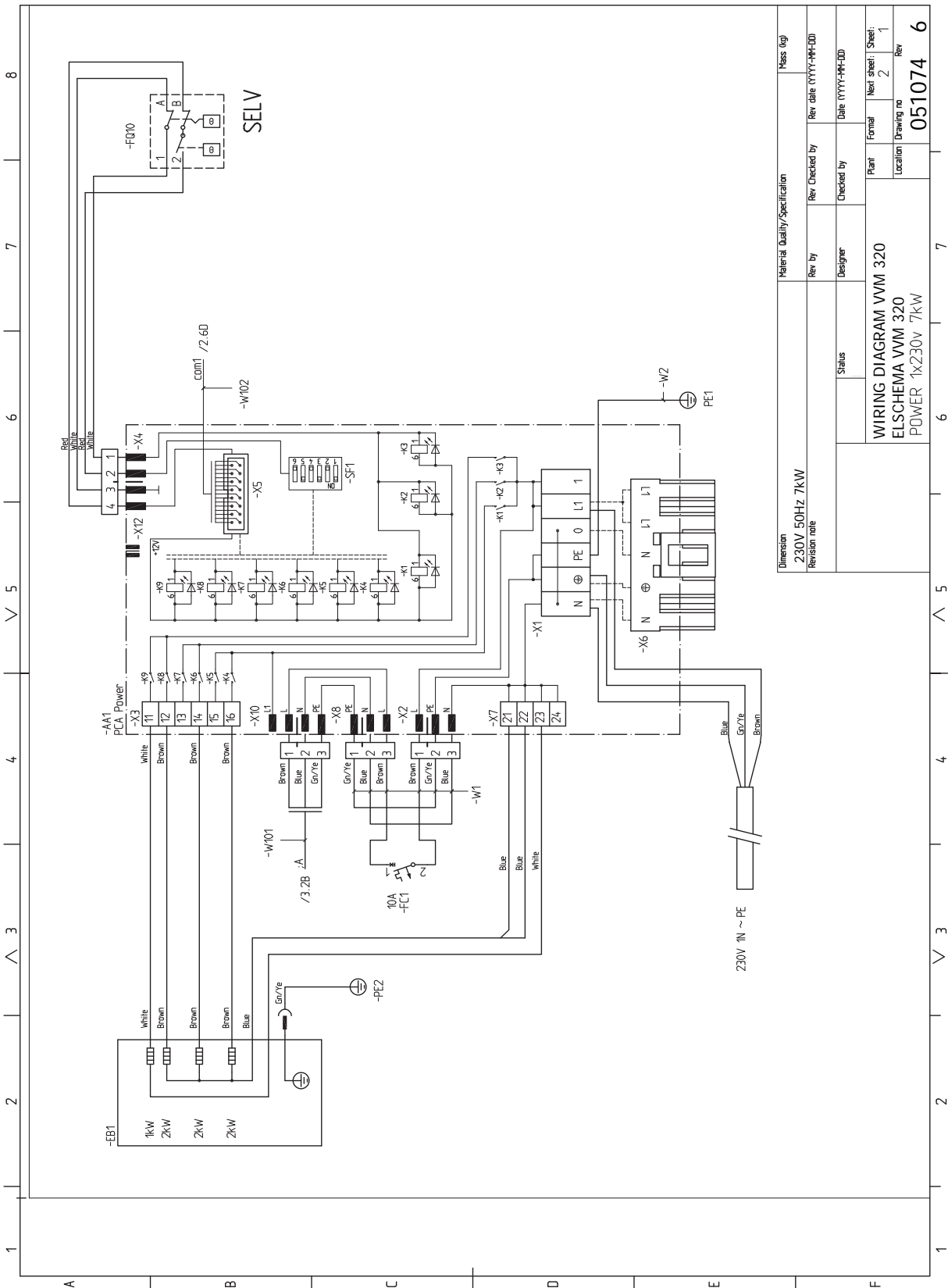

Dimension 230V 50Hz 7kW Revision note	Material Quality/Specification	Mass (kg)
Rev by	Rev Checked by	Rev date (YYYY-MM-DD)
Status	Designer	Checked by
Plant	Location	Date (YYYY-MM-DD)
Formal	Drawing no	New sheet: 1
Location		Sheet: 2
		Rev
		051074
		6

WIRING DIAGRAM VWM 320
ELSCHEMA VWM 320
POWER 1x230V 7kW

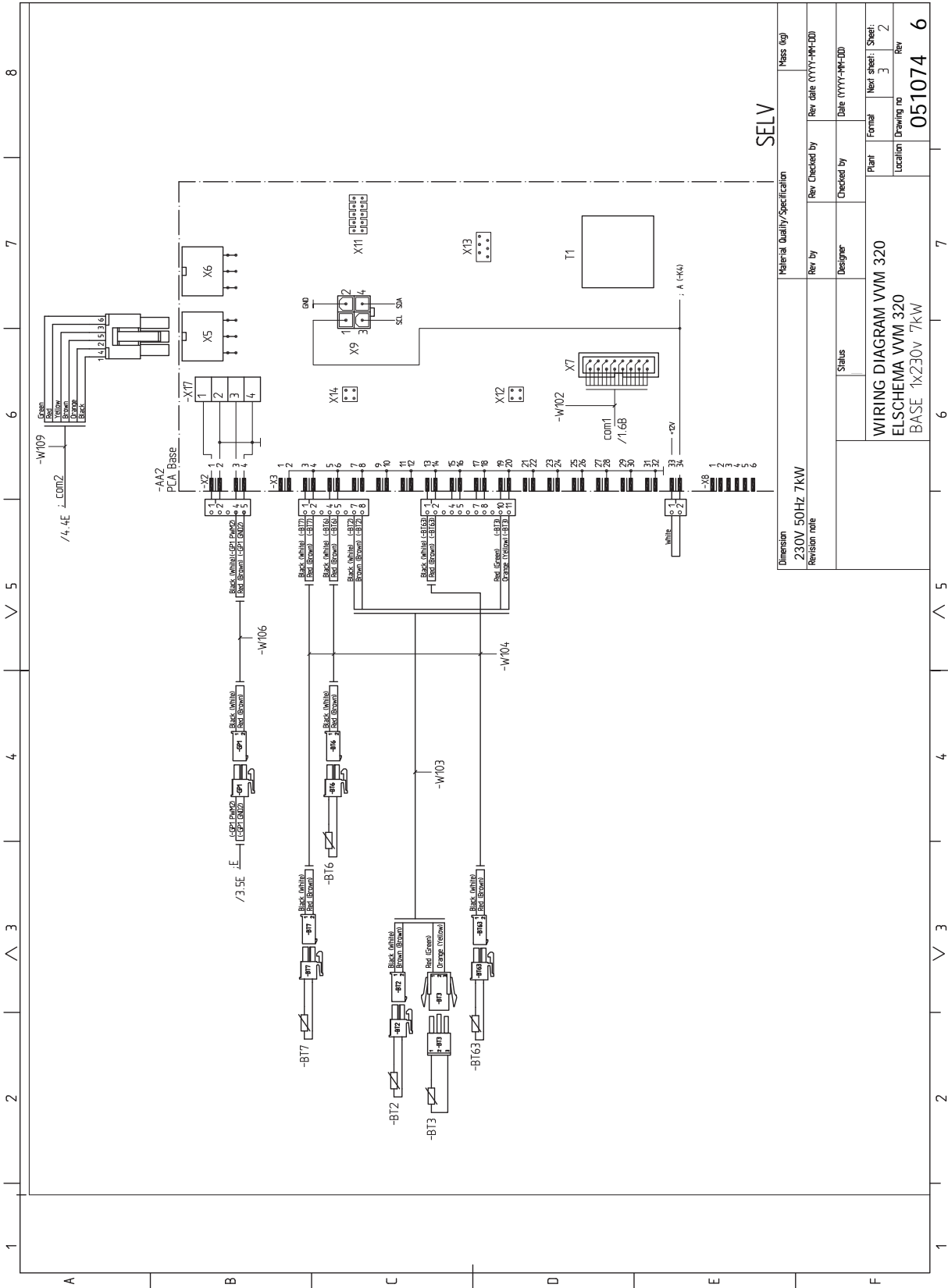

1 2 3 4 5 6 7 8

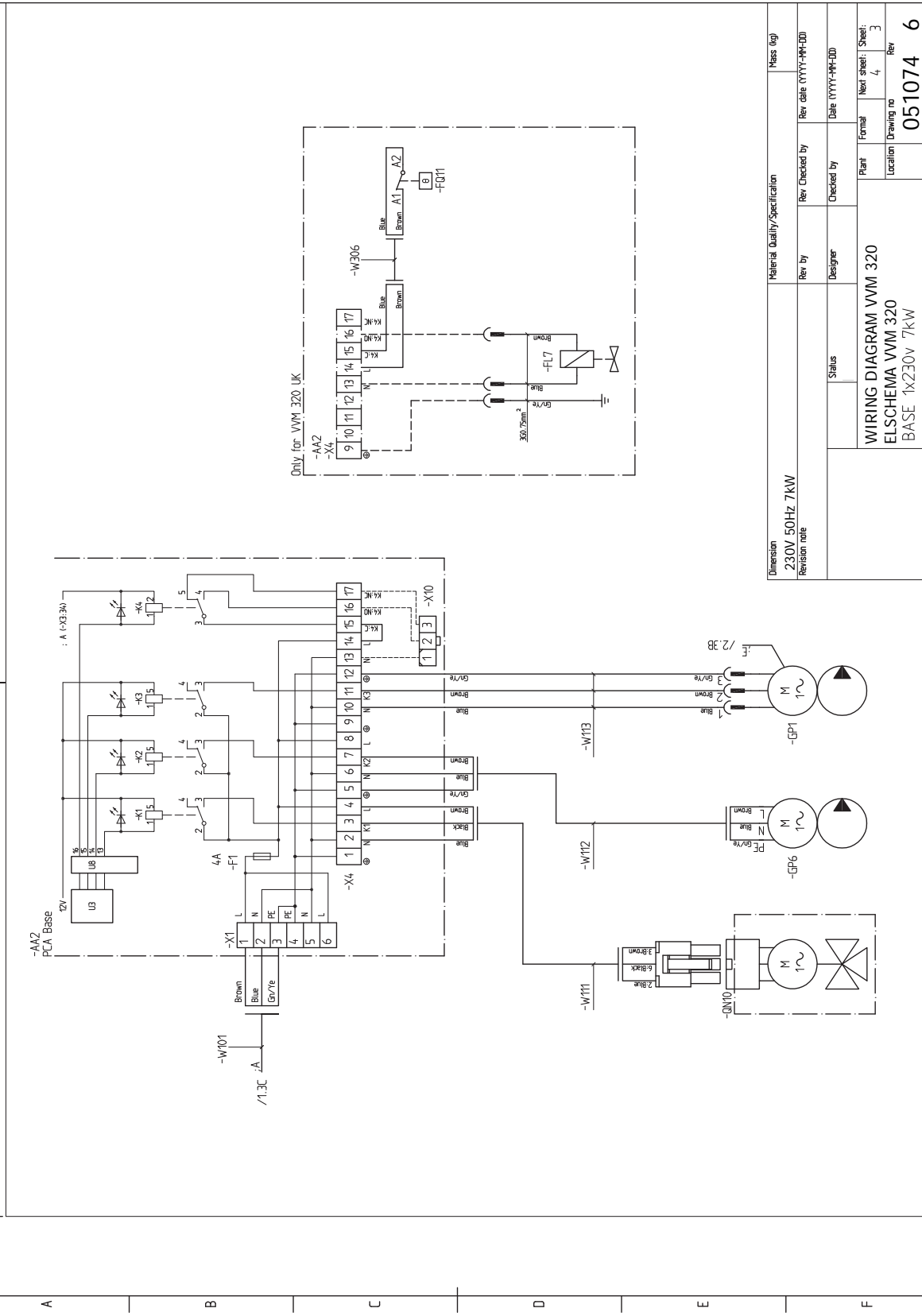

Material Quality/Specification		Mass (kg)	
Rev by	Rev Checked by	Rev table (YYYY-MM-DD)	Rev table (YYYY-MM-DD)
Designer	Checked by	Date (YYYY-MM-DD)	
Status		Plant	Next sheet: 4
		Location	Drawing no
		051074 6	

Dimension
230V 50Hz 7kW
Revision note

WIRING DIAGRAM VVM 320
ELSCHEMA VVM 320
BASE 1x230v 7kW

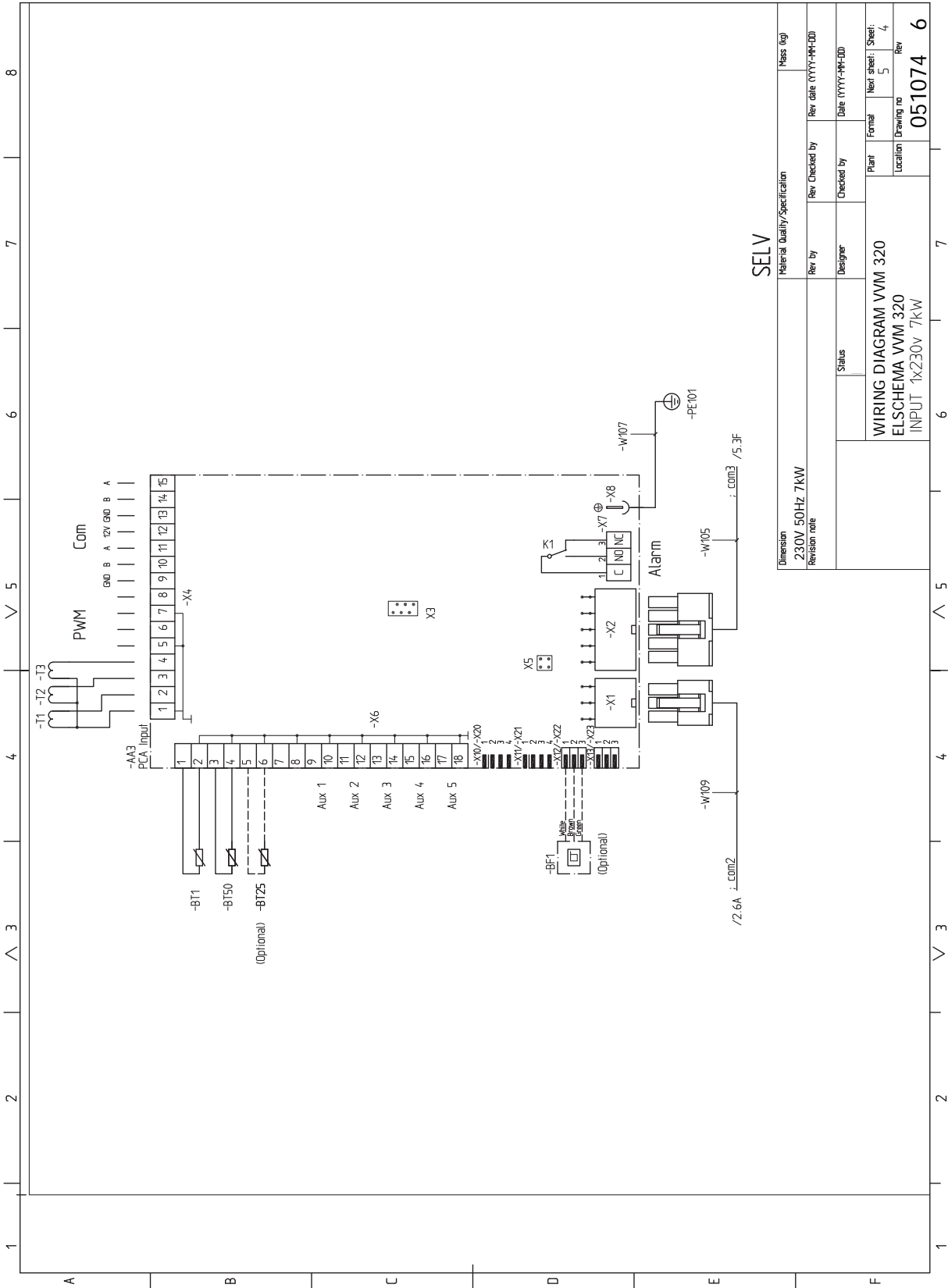

SELV

Dimension		Material Quality/Specification		Mass (kg)	
230V 50Hz 7kW					
Revision note		Rev by	Rev Checked by	Rev table (YYYY-MM-DD)	Rev (YYYY-MM-DD)
		Designer	Checked by	Date (YYYY-MM-DD)	
		Status		Plant	Formal
				Location	Next sheet: Sheet: 5 4
		WIRING DIAGRAM VWM 320			Drawing no
		ELSICHEMA VWM 320			Rev
		INPUT 1x230V 7kW			051074

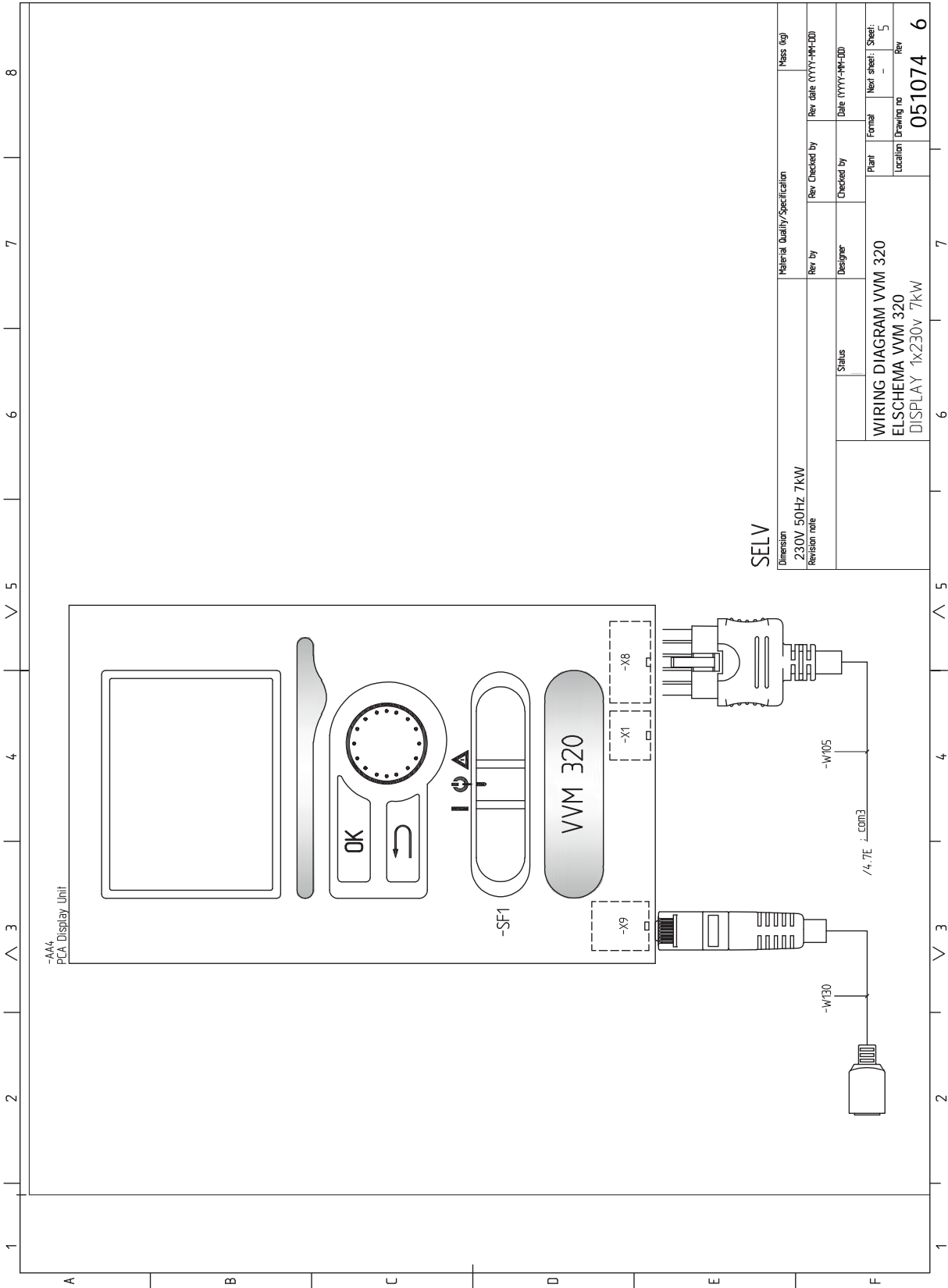

SELV

Material Quality/Specification		Mass (kg)	
Dimension	230V 50Hz 7kW	Rev By	Rev table (YYYY-MM-DD)
Revision note		Designer	Date (YYYY-MM-DD)
Status		Checked by	Formal
WIRING DIAGRAM VVM 320		Plant	Next sheet: 5
ELSICHEMA VVM 320		Location	Drawing no
DISPLAY 1x230v 7kW			Rev
			051074 6

Item register

- A**
- Accessibility, electrical connection, 21
- Accessories, 64
- Alarm, 61
- Assembly, 8
- B**
- Back button, 40
- C**
- Cable lock, 22
- Cold and hot water, 18
 - Connecting cold and hot water, 18
- Commissioning and adjusting, 34
 - Commissioning without heat pump, 36
 - Filling and venting, 34
 - Pool, 39
 - Post-adjustment, venting, 36
 - Preparations, 34
 - Setting hot water circulation, 38
 - SG Ready, 39
 - Start guide, 35
 - Start-up and inspection, 35
- Commissioning without heat pump, 36
- Compatible Air/water heat pumps, 7
- Connecting accessories, 32
- Connecting current sensors, 28
- Connecting external operating voltage for the control system, 24
- Connecting hot water circulation, 19
- Connecting the climate system, 18
- Connecting to heat pump, 18
- Connection as electric boiler, 18
- Connections, 23
- Control, 40, 44
 - Control - Introduction, 40
 - Control - Menus, 44
- Control - Introduction, 40
 - Display unit, 40
 - Menu system, 41
- Control knob, 40
- Control - Menus, 44
 - Menu 5 - SERVICE, 47
- Cooling mode indication, 30
- D**
- Delivery and handling, 8
 - Assembly, 8
 - Installation area, 8
 - Removing the covers, 10
 - Supplied components, 9
 - Transport, 8
- Dimensions and pipe connections, 17
- Dimensions and setting-out coordinates, 66
- Display, 40
- Display unit, 40
 - Back button, 40
 - Control knob, 40
 - Display, 40
 - OK button, 40
 - Status lamp, 40
 - Switch, 40
- Disturbances in comfort, 61
 - Alarm, 61
 - Manage alarm, 61
 - Only additional heat, 63
 - Troubleshooting, 61
- Docking alternatives
 - Two or more climate systems, 19
- Draining the climate system, 34, 57
- Draining the hot water heater, 57
- E**
- Electrical addition - maximum output, 26
 - Power steps of the immersion heater, 26
- Electrical circuit diagram, 70
- Electrical connections, 20, 25
 - Accessibility, electrical connection, 21
 - Cable lock, 22
 - Communication, 25
 - Connecting accessories, 32
 - Connecting external operating voltage for the control system, 24
 - Connections, 23
 - Electrical addition - maximum output, 26
 - External connection options (AUX), 28
 - General, 20
 - Load monitor, 28
 - Miniature circuit-breaker, 20
 - NIBE Uplink, 28
 - Optional connections, 28
 - Outdoor sensor, 24
 - Power connection, 23
 - Removing the cover, base board, 21
 - Removing the cover, immersion heater circuit board, 21
 - Removing the hatch, input circuit board, 21

- Room sensor, 25
- Settings, 26
- Temperature limiter, 21
- Temperature sensor, external flow line, 23
- External connection options (AUX), 28
 - Cooling mode indication, 30
 - Extra circulation pump, 30
 - Hot water circulation, 30
 - Optional selection for AUX output (potential-free variable relay), 30
- Extra circulation pump, 30

F

- Filling and venting, 34
 - Draining the climate system, 34
 - Filling the hot water heater, 34
 - Filling VVM 320, 34
 - Venting the climate system, 34
- Filling the hot water heater, 34
- Filling VVM 320, 34

H

- Heating medium side, 18
 - Connecting the climate system, 18
- Help menu, 43
- Hot water circulation, 30

I

- Important information, 4
 - Compatible Air/water heat pumps, 7
 - Inspection of the installation, 6
 - Marking, 4
 - Outdoor modules, 7
 - Recovery, 5
 - Safety information, 4
 - Symbols, 4
- Indoor module's design, 12
 - Component locations, 12
 - List of components, 13
- Initial pressure, 15
- Inspection of the installation, 6
- Installation alternative, 18
 - Connecting hot water circulation, 19
 - Connecting to heat pump, 18
 - Connection as electric boiler, 18
 - Water heater with immersion heater, 18
- Installation area, 8

M

- Manage alarm, 61
- Marking, 4
- Menu 5 - SERVICE, 47
- Menu system, 41
 - Help menu, 43
 - Operation, 42
 - Scroll through the windows, 43
 - Selecting menu, 42
 - Selecting options, 42
 - Setting a value, 42
 - Use the virtual keyboard, 43
- Miniature circuit-breaker, 20

N

- NIBE Uplink, 28

O

- OK button, 40
- Only additional heat, 63
- Operation, 42
- Optional connections, 28
 - Possible selections for AUX inputs, 29
- Outdoor modules, 7
- Outdoor sensor, 24

P

- Pipe connections, 14
 - Boiler and radiator volumes, 15
 - Cold and hot water
 - Connecting cold and hot water, 18
 - Dimensions and pipe connections, 17
 - General pipe connections, 14
 - Heating medium side, 18
 - Installation alternative, 18
 - Symbol key, 16
 - System diagram, 15
- Pool, 39
- Possible selection for AUX inputs, 29
- Possible selection for AUX output (potential free variable relay), 30
- Post-adjustment, venting, 36
- Power connection, 23
- Preparations, 34
- Pump speed, 36

R

- Recovery, 5
- Removing the cover, base board, 21
- Removing the cover, immersion heater circuit board, 21
- Removing the covers, 10
- Removing the hatch, input circuit board, 21
- Room sensor, 25

S

- Safety information, 4
 - Marking, 4
 - Serial number, 5
 - Symbols, 4
- Scroll through the windows, 43
- Selecting menu, 42
- Selecting options, 42
- Serial number, 5
- Service, 57
 - Service actions, 57
- Service actions, 57
 - Draining the climate system, 57
 - Draining the hot water heater, 57
 - Standby mode, 57
 - Temperature sensor data, 58
 - USB service outlet, 58
- Setting a value, 42
- Setting hot water circulation, 38
- Settings, 26
 - Emergency mode, 26

- SG Ready, 39
- Standby mode, 26, 57
 - Power in emergency mode, 26
- Start guide, 35
- Start-up and inspection, 35
 - Pump speed, 36
- Status lamp, 40
- Supplied components, 9
- Switch, 40
- Symbol key, 16
- Symbols, 4
- System diagram, 15

T

- Technical data, 66
 - Dimensions and setting-out coordinates, 66
 - Electrical circuit diagram, 70
 - Technical Data, 67
- Technical Data, 67
- Temperature limiter, 21
 - Resetting, 21
- Temperature sensor, external flow line, 23
- Temperature sensor data, 58
- Transport, 8
- Troubleshooting, 61

U

- USB service outlet, 58
- Use the virtual keyboard, 43

V

- Venting the climate system, 34

Contact information

AUSTRIA

KNV Energietechnik GmbH
Gahberggasse 11, 4861 Schörfling
Tel: +43 (0)7662 8963-0
mail@knv.at
knv.at

CZECH REPUBLIC

Družstevní závody Dražice - strojírna
s.r.o.
Dražice 69, 29471 Benátky n. Jiz.
Tel: +420 326 373 801
nibe@nibe.cz
nibe.cz

DENMARK

Vølund Varmeteknik A/S
Industrivej Nord 7B, 7400 Herning
Tel: +45 97 17 20 33
info@volundvt.dk
volundvt.dk

FINLAND

NIBE Energy Systems Oy
Juurakkotie 3, 01510 Vantaa
Tel: +358 (0)9 274 6970
info@nibe.fi
nibe.fi

FRANCE

NIBE Energy Systems France SAS
Zone industrielle RD 28
Rue du Pou du Ciel, 01600 Reyrieux
Tél: 04 74 00 92 92
info@nibe.fr
nibe.fr

GERMANY

NIBE Systemtechnik GmbH
Am Reiherpfahl 3, 29223 Celle
Tel: +49 (0)5141 75 46 -0
info@nibe.de
nibe.de

GREAT BRITAIN

NIBE Energy Systems Ltd
3C Broom Business Park,
Bridge Way, S41 9QG Chesterfield
Tel: +44 (0)845 095 1200
info@nibe.co.uk
nibe.co.uk

NETHERLANDS

NIBE Energietechnik B.V.
Energieweg 31, 4906 CG Oosterhout
Tel: +31 (0)168 47 77 22
info@nibenl.nl
nibenl.nl

NORWAY

ABK-Qviller AS
Brobekkveien 80, 0582 Oslo
Tel: (+47) 23 17 05 20
post@abkqviller.no
nibe.no

POLAND

NIBE-BIAWAR Sp. z o.o.
Al. Jana Pawla II 57, 15-703 Bialystok
Tel: +48 (0)85 66 28 490
biawar.com.pl

RUSSIA

EVAN
bld. 8, Yuliusa Fuchika str.
603024 Nizhny Novgorod
Tel: +7 831 419 57 06
kuzmin@evan.ru
nibe-evan.ru

SWEDEN

NIBE Energy Systems
Box 14
Hannabadsvägen 5, 285 21 Markaryd
Tel: +46 (0)433-27 3000
info@nibe.se
nibe.se

SWITZERLAND

NIBE Wärmetechnik c/o ait Schweiz
AG
Industriepark, CH-6246 Altishofen
Tel. +41 (0)58 252 21 00
info@nibe.ch
nibe.ch

For countries not mentioned in this list, contact NIBE Sweden or check nibe.eu for more information.

NIBE Energy Systems
Hannabadsvägen 5
Box 14
SE-285 21 Markaryd
info@nibe.se
nibe.eu

IHB EN 2028-11 231357

This manual is a publication from NIBE Energy Systems. All product illustrations, facts and data are based on the available information at the time of the publication's approval. NIBE Energy Systems makes reservations for any factual or printing errors in this manual.

©2020 NIBE ENERGY SYSTEMS

