

## Installation and Operating Manual

UKV 20-40  
UKV 20-100

Buffer tanks

*All installation diagrams in this manual do not replace the system design; they can only be used for illustrative purposes. The product is not intended for use by persons with reduced physical fitness/mental efficiency or without sufficient experience and knowledge, if they are not supervised or instructed by a person responsible for their safety. Operation of the product by children is strictly prohibited.*

*We reserve the right to make the product design changes and changes in the manual.*

©NIBE 2017

# Content

<b>1 General</b> _____	<b>4</b>	<b>4 Service</b> _____	<b>9</b>
Introduction _____	4	<b>5 Recycling and disposal</b> _____	<b>9</b>
Intended Use _____	4	<b>6 Technical data</b> _____	<b>10</b>
<b>2 Design</b> _____	<b>5</b>	Dimensions _____	10
<b>3 Installation</b> _____	<b>6</b>		
Location of the Tank _____	6		
Installation Requirements _____	6		
Installation of the Temperatur Sensor _____	7		
Installation of electric heating module _____	8		
Warnings and Practical Recommendations _____	8		

# 1 General

## Introduction

Thank you for your confidence and choice of equipment by NIBE. To fully benefit from the advantages of this product, please read this Manual before using it, and in particular chapters relating to the application, installation and maintenance, and warranty. Please keep this Manual in a safe place for future reference.

### CAUTION

**Sections of the Manual relating to the installation, inspection and maintenance are intended for the qualified installer.**

### CAUTION

**The manufacturer shall not be held liable for any damages caused by failure to comply with the recommendations and observations contained in this Manual.**

## Intended Use

Buffer tanks are used for storage and transfer of energy contained in the heating medium. The main task of the buffer tanks with capacities of 40 L and 100 L is to increase capacity of the heating circuit. In addition, the 100 L tank is a hydraulic coupler in the heating system. The accumulated energy is transferred to the heating system. Buffer tanks can operate with a variety of heat sources in central heating systems such as heat pumps, solid fuel boilers, solar heating systems, etc. When used in the system containing a solid fuel-fired boiler, the low capacity tank improves the uniform heat removal. It reduces the amount of fire ups and additionally enables the boiler operation at the design power rating. This also enhances the efficiency and life of the boiler.

When operating with a heat pump, the buffer tank task is to increase the capacity of the heating system. The use of buffer limits the number of compressor start-ups, which extends its life. NIBE buffer tanks enable operation with virtually any type of central heating system. During the installation and operation, always follow the instructions in this Manual.

### CAUTION

**Buffer tanks are designed for heating up and supplying the heating medium. Any inappropriate use, not in compliance with its intended use is not permitted. Neither manufacturer nor supplier shall be responsible for damages resulting from this.**

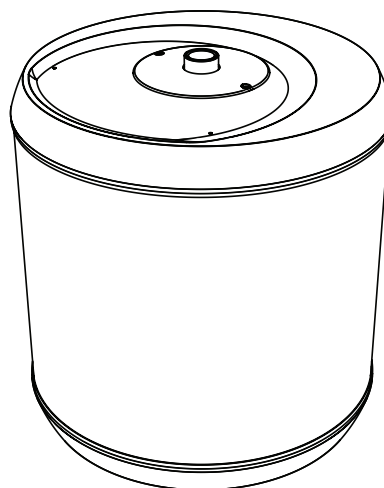

Fig. 1 UKV 20-40 buffer tank.

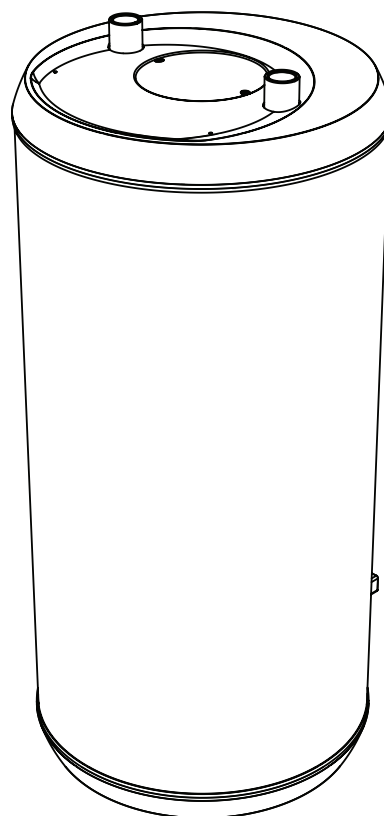
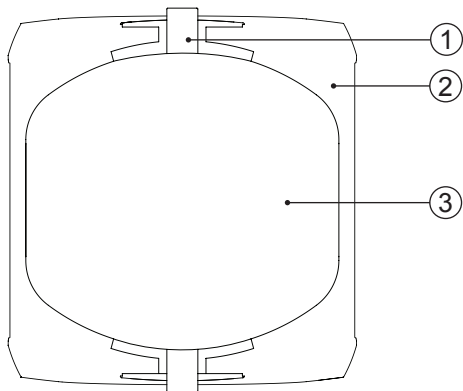

Fig. 2 UKV 20-100 buffer tank.

## 2 Design

UKV Buffer tanks by NIBE are made of high quality steel sheet, coated on the outside with anti-corrosion paint. Specially selected tank insulation provides excellent thermal insulation properties of these devices. All devices in the Series are in aesthetic plastic body. Tanks have connector pipes and temperature sensor cover for mounting the sensor and temperature measurement at different levels in the tank, as well as connectors for mounting an electrical heating unit.



**Fig. 3** Section of the UKV 20-40 buffer tank

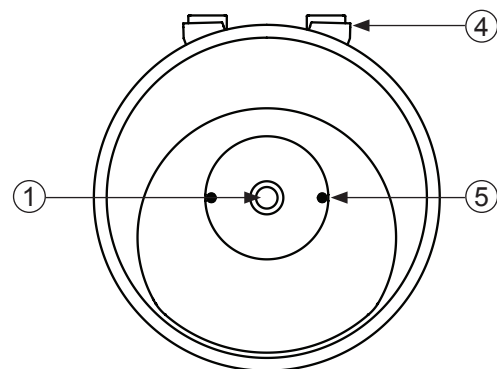

**Fig. 5** Upper view of the UKV 20-40 buffer tank

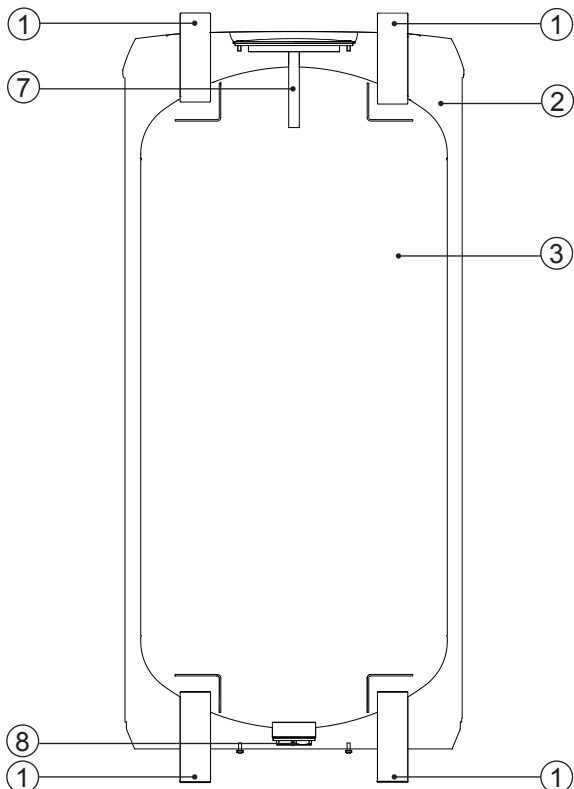

**Fig. 4** Section of the UKV 20-100 buffer tank

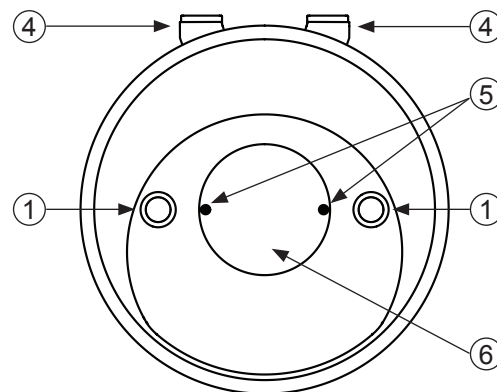

**Fig. 6** Upper view of the UKV 20-100 buffer tank

**DESCRIPTION:**

1. Connector pipe
2. Tank insulation.
3. Steel tank.
4. Bracket.
5. Screw.
6. Cover.
7. Temperature sensor cover.
8. Heating element connector.

# 3 Installation

## Location of the Tank

Buffer tanks of UKV Series should be installed in a dry area, protected against temperatures below 0°C (e.g. in the basement, boiler room, etc.). Location and manner of installation must ensure trouble-free maintenance and servicing of the unit in the future.

To suspend the unit, use the auxiliary brackets attached to the product. With  $\varnothing 12$  dowels and  $\varnothing 8$  screws (included), secure the brackets horizontally to a suitably hard wall, i.e. made of concrete, solid bricks, etc. When suspending on the walls of lower carrying capacity, e.g. made of gypsum, hollow bricks, etc., use a different kind of dowels and screws to ensure stable mounting of the unit. After mounting the bracket, hang the unit on the main bracket.

The manufacturer shall not be liable for damages resulting from improper installation of the tank.

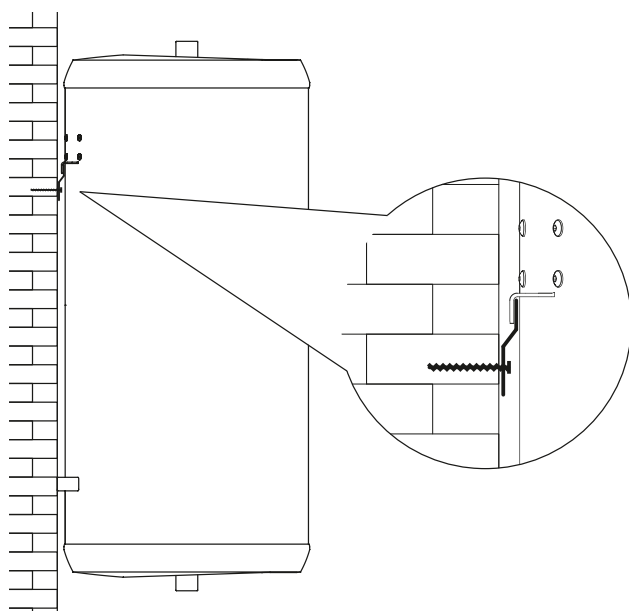

Fig. 7 Mounting the unit on the hanger.

## Installation Requirements

### CAUTION

*Installation and commissioning of the buffer tank shall only be done by appropriately qualified installer. The installer should inform the user of the functions of the product and provide the necessary information on its safe use.*

Buffer tanks Series UKV can be connected to open or closed central heating systems. Pressure in the C/H system may not exceed the max operating temperature of the unit (for the allowable operating parameters of the units, see Table 2 Technical data.) Connect the buffer tank in accordance with the installation

diagram. Remember to install the appropriate safety valves.

### Open System

UKV buffer tanks can be included in an open C/H system protected in accordance with actual norms or standards of protection.

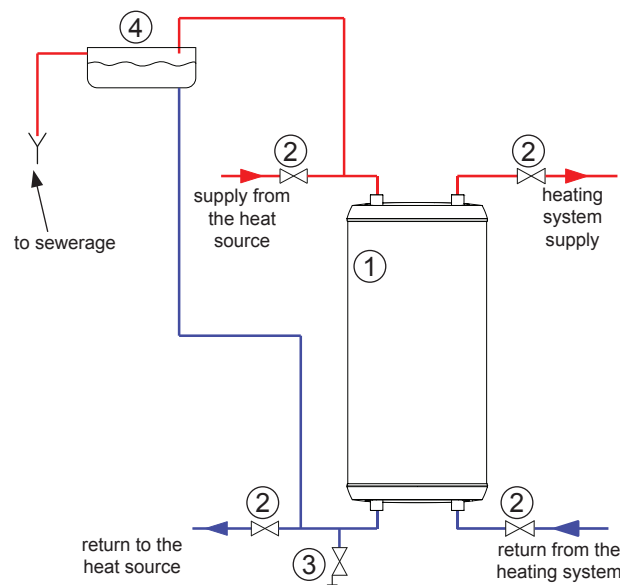

Fig. 8 Diagram of the UKV 20-100 buffer tank installation in an open system

### DESCRIPTION:

1. Buffer tank
2. Cut-off valve
3. Drain valve
4. Opened Expansion tank

### Closed System

Buffer tanks Series UKV can be connected to a closed C/H system in accordance with relevant regulations and standards.

Buffer tank operating in a closed circuit must be equipped with correctly dimensioned safety valve (preferably in the heating medium return line to the heating source), with blow-off pressure not exceeding the max operating pressure of the unit (for the max operating pressures of the units, see Table 1 Technical data.) Some amount of the heating medium can leak from the safety valve during normal operation, therefore, you should install a drain line in the safety valve, allowing safe drain of the heating medium to the sewerage or drain grate. Safety valve drain line should be installed with a decline, in an environment free of freezing and remain open to the atmosphere. NIBE is not responsible for flooding the room through the safety valve.

### TIP

When connecting the buffer tank to a closed C/H system, you have to install an additional or increase capacity of the existing expansion vessel.

### CAUTION

In closed systems, use of a safety with blow-off pressure not exceeding the max operating pressure of the unit is mandatory (for the max operating pressures of the units, see Table 1 Technical data.)

### CAUTION

Water can drip from the safety valve, which is normal and you should never prevent it, since blocking of the safety valve can cause a threat to the user's safety.

### CAUTION

Installation of necking of any kind (such as reducers, dirt pockets, cut-off valves, etc.) between the safety valve or open expansion tank and the buffer is not allowed. Only a T-pipe with a drain valve and a T-pipe with an expansion vessel may be installed in these line sections.

### CAUTION

Never use the equipment with clogged safety valves.

### CAUTION

Check the operation of the safety valve periodically as described by the manufacturer of the valve in order to check whether it is not clogged.

### TIP

The lower return connections to the heating source and from the heating system can be connected in opposite configuration.

### TIP

We recommend connecting the tank connector pipes with the system lines by means of unions to allow disconnection of the tank, if required.

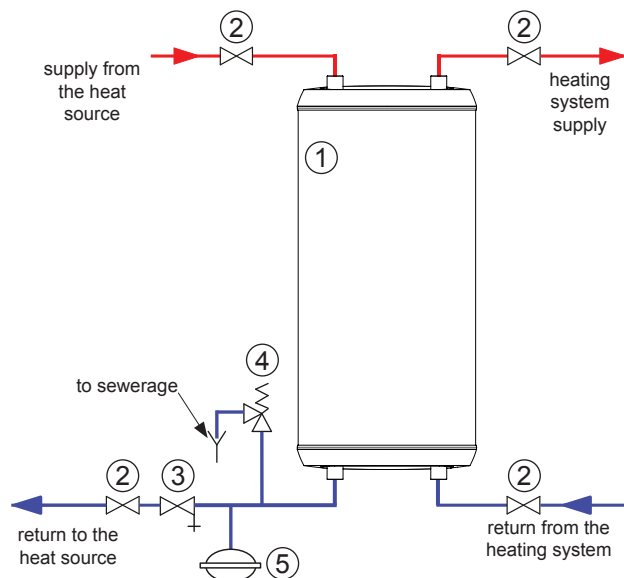

Fig.9 Diagram of the UKV 20-100 buffer tank installation in a closed system.

### DESCRIPTION:

1. Buffer tank
2. Cut-off valve
3. Drain valve
4. Safety valve
5. Expansion vessel

### CAUTION

The storage tank connections may not be made of materials more precious than carbon steel due to the increased electrochemical corrosion. This applies to connector pipes (fittings) contacting the tank connector pipe thread. Preferably, use galvanized connector pipes (fittings.)

## Installation of the Temperature Sensor (only UKV 20-100)

UKV 20-100 buffer tanks have enclosure for the temperature sensor. In order to install the temperature sensor (Fig. 10):

1. Remove the screws securing the enclosure cover. (1)
2. Remove the enclosure cover together with thermal insulation. (1)
3. Drill a hole in the cover to enable insertion of the temperature sensor. (2)
4. Insert the sensor through the cover, and into the temperature sensor cover. (3)
5. Reinstall the enclosure cover together with thermal insulation.

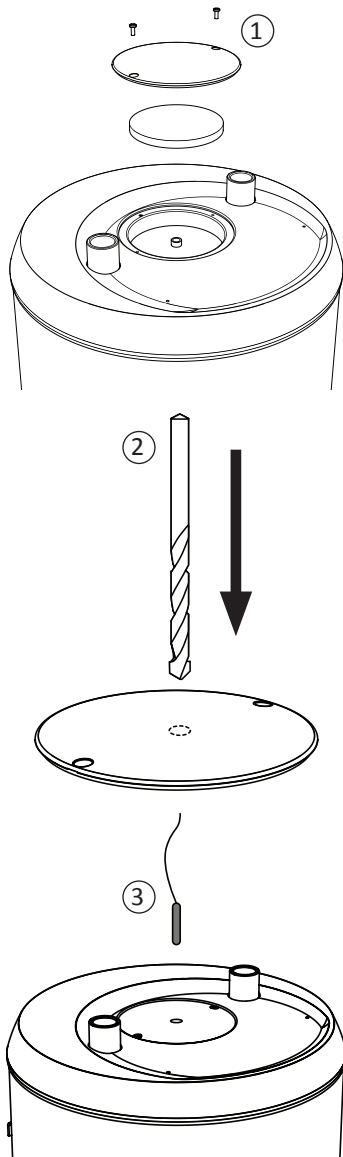
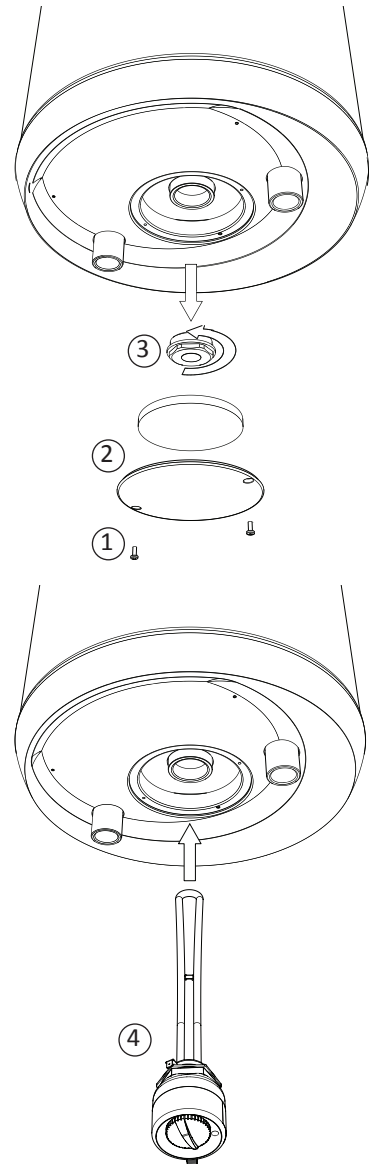

**Fig. 10** Installation of the temperature sensor

### Installation of electric heating module (ONLY UKV 20-100)

In UKV 20-100 buffer tanks, it is possible to install an electric heating module. To install the module (Fig. 11):

1. Unscrew the screws that secure the housing cover. (1)
2. Remove the housing cover including thermal insulation. (2)
3. Unscrew the plug for securing the connection. (3)
4. Screw the electrical heating element into the socket. (4) The thread should be sealed with sealing material.



**Fig. 11** Installation of electric heating module

### Warnings and Practical Recommendations

#### Practical Recommendations:

- Limit the setpoints of the heating medium temperature controllers in the buffer tank supply lines to 85 °C.
- Check the operation of the safety valve periodically as described by the manufacturer of the valve in order to check whether it is not clogged
- Report any malfunctions in the buffer tank operation to the authorized service centres.
- Open the vent to vent the buffer tank before the heating season start.
- Check filling of the C/H system from time to time.



### Warnings:

- Never activate circulation of the heating medium unless the buffer tank is filled with the heating medium.
- Never operate the buffer tank if you find any malfunction in the safety valve operation.
- Never install any device (such as cut-off and/or check valves, etc.) between the tank and the safety valve or open expansion tank (except T-pipes.)
- Any repairs of the buffer tank by the user are forbidden.
- Stopping water leaks from the safety valve is not allowed.

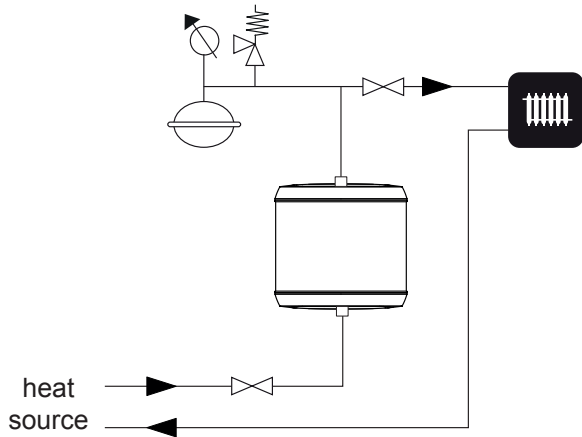

**Fig. 12** Installation of the UKV 20-40 buffer tank in series in order to increase the heating system capacity

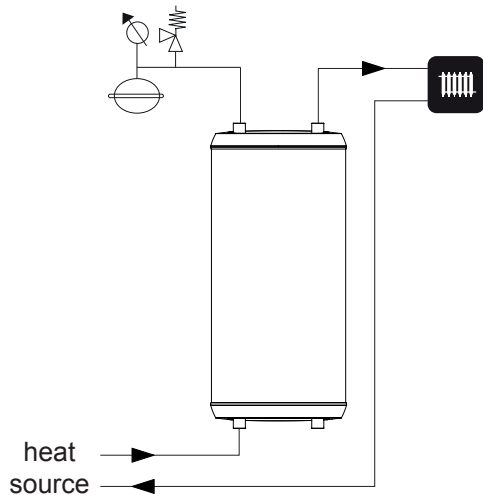

**Fig. 13** Installation of the UKV 20-100 buffer tank in series in order to increase the heating system capacity

## 4 Service

Report any malfunctions in the buffer tank operation to the authorized service centres.

### CAUTION

*The tank may only be repaired / serviced by an authorized service since improper repair can cause safety risks, and the loss of product warranty.*

## 5 Recycling and disposal

According to the NIBE rules, the products have been manufactured of high quality materials using the latest technologies and solutions that do not endanger the environment.

When selecting materials, we took into account both the possibility of reuse of materials (recycling) that can be disassembled and separated from materials unsuitable for recycling, as well as risks arising from the processing of materials not intended to reuse.

The purchased device consists in more than 90 % of parts that can be recycled and reused, so they are safe for the environment and human health.

### CAUTION

*In order to prevent damage to piping systems and environmental pollution, the product should only be disassembled and taken out of service by appropriately qualified specialists.*

### CAUTION

*At end-of-life, take care that the product and all the equipment were disposed of in accordance with applicable regulations.*

### TIP

*The packaging, in which the product is delivered, is made mainly of materials suitable for recycling and utilization. After installation, you should ensure the proper disposal of packaging in accordance with applicable regulations.*

# 6 Technical data

**Tabel 1.** Technical data.

Parameter	U/m	Buffer type	
		UKV 20-40	UKV 20-100
Energy efficiency class	-	B	C
Storage volume (V)*	l	38,5	97,5
Standing loss (S)*	W	28,3	59,6
Max tank operating temp.	°C	85	
Max tank operating pressure	bar	6	
Weight	kg	17	34

\* Acc. to EU regulations No. 812/2013 & 814/2013.

## Dimensions

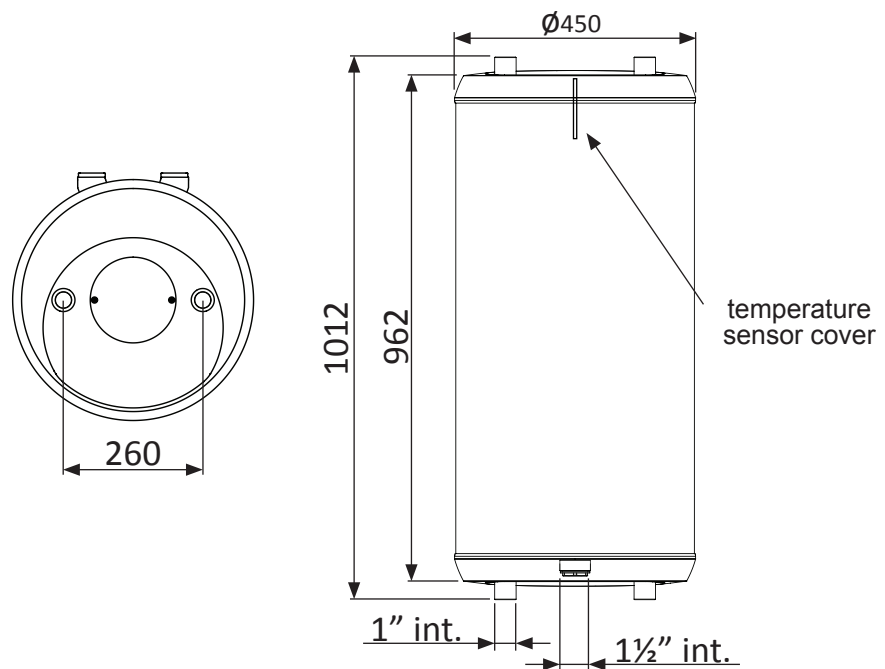

**Fig. 14** Dimensions of the UKV 20-100 buffer tanks

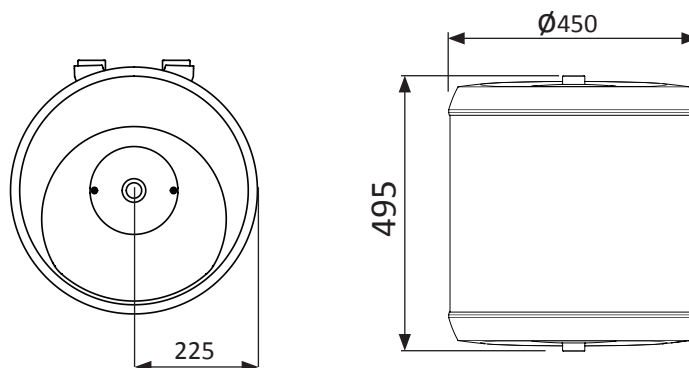

**Fig. 15** Dimensions of the UKV 20-40 buffer tanks

# Notes:

AT

**KNV Energietechnik GmbH**, Gahberggasse 11, 4861 Schörfling

Tel: +43 (0)7662 8963-0 Fax: +43 (0)7662 8963-44 E-mail: mail@knv.at www.knv.at

CH

**NIBEWärmetechnik c/o ait Schweiz AG**, Industriepark, CH-6246 Altishofen

Tel: (52) 647 00 30 Fax: (52) 647 00 31 E-mail: info@nibe.ch www.nibe.ch

CZ

**Druzstevni zavody Drazice s.r.o**, Drazice 69, CZ - 294 71 Benatky nad Jizerou

Tel: +420 326 373 801 Fax: +420 326 373 803 E-mail: nibe@nibe.cz www.nibe.cz

DE

**NIBE Systemtechnik GmbH**, Am Reiherpfahl 3, 29223 Celle

Tel: 05141/7546-0 Fax: 05141/7546-99 E-mail: info@nibe.de www.nibe.de

DK

**Vølund Varmeteknik A/S**, Member of the Nibe Group, Brogårdsvej 7, 6920 Videbæk

Tel: 97 17 20 33 Fax: 97 17 29 33 E-mail: info@volundvt.dk www.volundvt.dk

FI

**NIBE Energy Systems OY**, Juurakkotie 3, 01510 Vantaa

Puh: 09-274 697 0 Fax: 09-274 697 40 E-mail: info@nibe.fi www.nibe.fi

FR

**NIBE Energy Systems France Sarl**, Zone industrielle RD 28, Rue du Pou du Ciel, 01600 Reyrieux

Tel : 04 74 00 92 92 Fax : 04 74 00 42 00 E-mail: info@nibe.fr www.nibe.fr

GB

**NIBE Energy Systems Ltd**, 3C Broom Business Park, BridgeWay, Chesterfield S41 9QG

Tel: 0845 095 1200 Fax: 0845 095 1201 E-mail: info@nibe.co.uk www.nibe.co.uk

NL

**NIBE Energietechnik B.V.**, Postbus 634, NL 4900 AP Oosterhout

Tel: 0168 477722 Fax: 0168 476998 E-mail: info@nibenl.nl www.nibenl.nl

NO

**ABK AS**, Brobekkveien 80, 0582 Oslo, Postadresse: Postboks 64 Vollebekk, 0516 Oslo

Tel. sentralbord: +47 23 17 05 20 E-mail: post@abkklima.no www.nibeenergysystems.no

PL

**NIBE-BIAWAR Sp. z o. o.** Aleja Jana Pawła II 57, 15-703 BIAŁYSTOK

Tel: 085 662 84 90 Fax: 085 662 84 14 E-mail: sekretariat@biawar.com.pl www.biawar.com.pl

RU

© „EVAN” 17, per. Boynovskiy, Nizhny Novgorod

Tel./fax +7 831 419 57 06 E-mail: info@evan.ru www.nibe-ewan.ru

**NIBE AB Sweden**, Box 14, Hannabadsvägen 5, SE-285 21 Markaryd

Tel: +46-(0)433-73 000 Fax: +46-(0)433-73 190 E-mail: info@nibe.se www.nibe.eu

For countries not mention in this list, please contact Nibe Sweden or check [www.nibe.eu](http://www.nibe.eu) for more information.