



Ground source heat pump

NIBE S1155

NIBE S1155 is an intelligent, inverter-controlled ground source heat pump without integrated hot water tank, which makes it easy to install in locations with low ceilings. A separate hot water tank is selected according to hot water requirements. NIBE S1155 provides optimum savings since the heat pump automatically adapts to your home's heating demand. NIBE is a leading player in the field of inverter technology, with many years' experience of output-regulating ground source heat pumps and one of the widest product ranges on the market.

NIBE S1155 has a high seasonal performance factor, resulting in low operating costs. The heat pump is available in four different output sizes: 1.5–6 kW, 3–12 kW, 4–16 kW and 6–25 kW and is suitable for both small and large properties.

With integrated wifi and the possibility to use wireless accessories, the S Series is a natural part of your connected home. Smart technology adjusts the indoor climate automatically while you're in complete control from phone or tablet. Giving high comfort and low energy consumption, while doing nature a favour at the same time.



- **Leading inverter technology and separate hot water tank for optimum customization.**
- **Four output sizes for optimal seasonal performance factor and low operating costs.**
- **User-friendly touch control, wireless accessories and integrated wireless connectivity with energy saving smart technology for high comfort.**

¹ NIBE VPB is available in the sizes 200, 300, 500, 750 and 1000 liters.

This is how S1155 works

Installation method

Rock

S1155 collects a proportion of the rock's stored solar energy via a collector in a borehole in the rock.

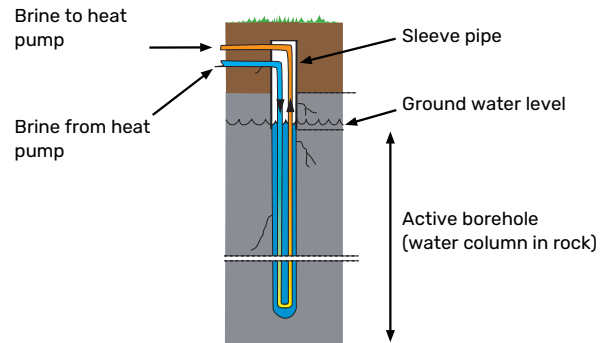
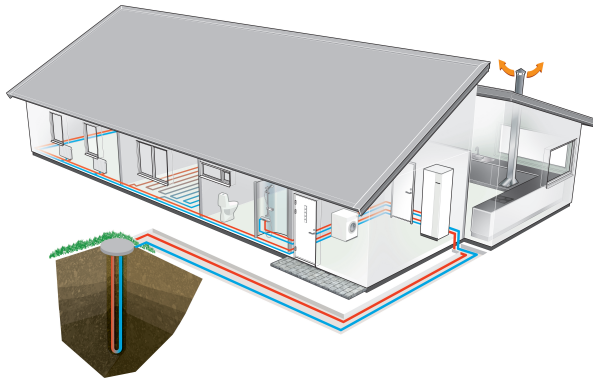

Ground

S1155 collects a proportion of the ground's stored solar energy via a buried ground collector.

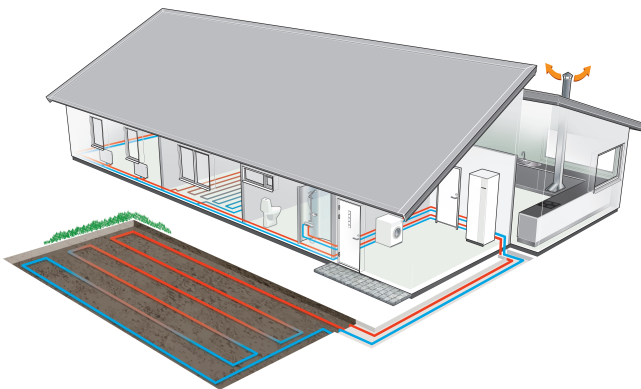

Lake

S1155 collects a proportion of the water's stored solar energy via a lake collector that is anchored on the lake bed.

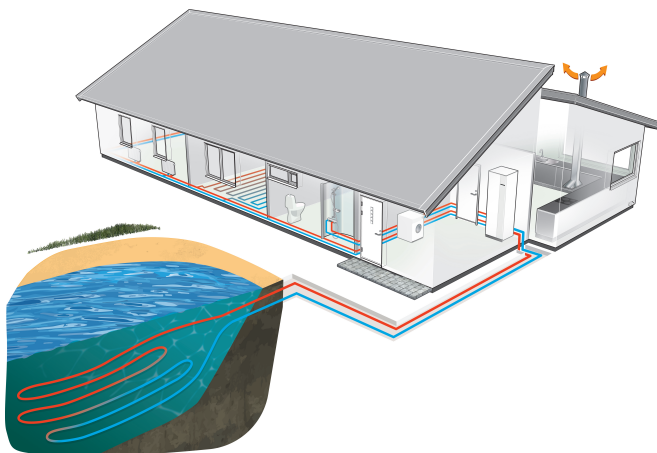

Design

S1155-6 has a 6.5 kW immersion heater while S1155-12, S1155-16 and S1155-25 have an integrated immersion heater of 7 kW with seven steps that connect automatically when needed. This can be switched to four steps of 9 kW.

S1155 is constructed on a robust frame with durable panels and effective soundproofing for the best possible comfort. All panels are easy to remove to facilitate installation and for any servicing.

Principle of operation

S1155 consists of heat pump, immersion heater, circulation pumps and control system. S1155 is connected to the brine and heating medium circuits.

The heat from the heat source (rock, soil, lake) is taken up via a closed brine system in which a mixture of water and antifreeze circulates. In some cases, the ground water can also be used as a heat source. An intermediate heat exchanger should be used to protect the heat pump in such cases.

In the heat pump evaporator, the brine (water mixed with anti-freeze, glycol or ethanol) releases its energy to the refrigerant, which is vaporised in order to be compressed in the compressor. The refrigerant, of which the temperature has now been raised, is passed to the condenser where it gives off its energy to the heating medium circuit and, if necessary, to any docked water heater. If there is a greater need for heating/hot water than the compressor can provide there is an integrated immersion heater.

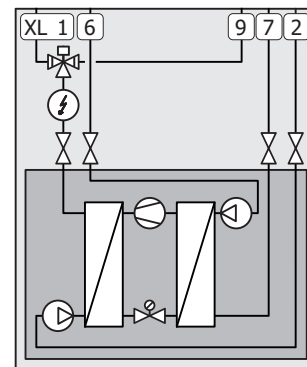

- XL1 Connection, heating medium flow
- XL2 Connection, heating medium return
- XL6 Connection, brine in
- XL7 Connection, brine out
- XL9 Connection, hot water heater

Good to know about S1155

Transport and storage

S1155 should be transported and stored vertically in a dry place. When being moved into a building, S1155 may be leant back 45 °.

The product can be tail heavy.

If the cooling module is pulled out and transported upright, S1155 can be transported on its back.

Remove the outer panels in order to protect them when moving in confined spaces inside buildings.

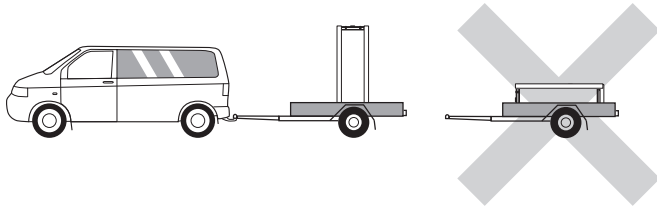

EXTRACTING THE COOLING MODULE

To simplify transport and service, the heat pump can be separated by pulling the cooling module out from the cabinet.

See section "Service" in the installer manual for comprehensive instructions about the separation.

Installation and positioning

- Place S1155 on a solid foundation indoors that can take the heat pump's weight.
- Because water comes from S1155, the area where the heating pump is located must be equipped with floor drainage.
- Install with its back to an outside wall, ideally in a room where noise does not matter, in order to eliminate noise problems. If this is not possible, avoid placing it against a wall behind a bedroom or other room where noise may be a problem.
- Wherever the unit is located, walls to sound sensitive rooms should be fitted with sound insulation.
- Route pipes so they are not fixed to an internal wall that backs on to a bedroom or living room.

INSTALLATION AREA

Leave a free space of 800 mm in front of the product. Approx. 50 mm free space is required on each side, to allow the side panels to be removed (see image). All service on S1155 can be carried out from the front, however the right-hand panel may need to be removed. Leave free space between the heat pump and the wall behind (and any routing of supply cables and pipes), to reduce the risk of any vibrations being propagated.

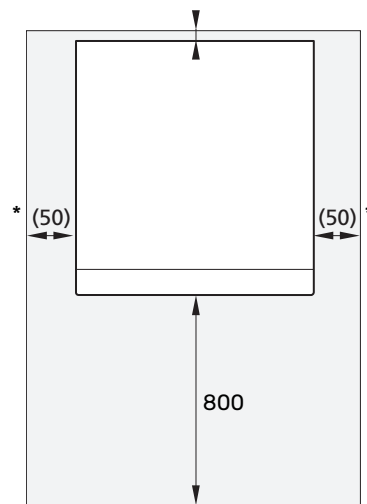

* A normal installation needs 300 – 400 mm (any side) for connection equipment, e.g. level vessel, valves and electrical equipment.

Supplied components

Local differences in the enclosed kit may occur. See relevant installer manual for more information.

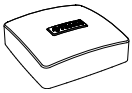

Outdoor temperature sensor
1 x



Room sensor
1 x



Current sensor¹
3 x



O-rings
8 x



Temperature sensor
3 x

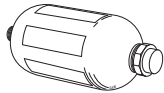

Level vessel¹
1 x



Aluminium tape
1 x

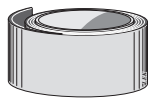

Insulation tape
1 x

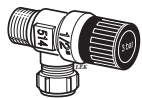

Safety valve
0.3 MPa (3 bar)¹
1 x



Filterball

6 KW

1 x G1
1 x G3/4

12/16 KW

1 x G1
1 x G1 1/4

25 KW

2 pcs G1 1/4



Compression ring couplings

6 KW

2 x (ø28 x G25)
3 x (ø22 x G20)

12/16 KW

5 x (ø28 x G25)

25 KW

5 x (ø35 x G32)

¹ Not Italy and the DACH countries.

Installation

Inspection of the installation

Current regulations require the heating installation to be inspected before it is commissioned. The inspection must be carried out by a suitably qualified person.

Pipe installation

Pipe installation must be carried out in accordance with current norms and directives. S1155 can operate with a return temperature of up to 58 °C and an outgoing temperature from the heat pump of 70 (65 °C with only the compressor).

S1155 is not equipped with external shut off valves; these must be installed to facilitate any future servicing.

Water may drip from the safety valve's overflow pipe. The overflow pipe must be routed to a suitable drain, so hot water splashes cannot cause harm. The entire length of the overflow pipe must be inclined to prevent water pockets, and must also be frost-proof. The overflow pipe must be at least the same size as the safety valve. The overflow pipe must be visible and its mouth must be open and not placed close to electrical components.

BRINE



The brine transports energy from a source to the heat pump using a liquid consisting of water mixed with antifreeze.

Insulate all indoor brine pipes against condensation.

Mark the brine system with the antifreeze that is used.

Install as follows:

- enclosed level vessel /expansion vessel

The level vessel must be installed as the highest point in the brine system on the incoming pipe before the brine pump (Alternative 1). If the level vessel cannot be placed at the highest point, an expansion vessel must be used (Alternative 2).

Note that condensation may drip from the level vessel. Position the vessel so that this does not harm other equipment.

- enclosed safety valve

The safety valve is fitted below the level vessel.

- pressure gauge

The pressure gauge is only required if an expansion vessel is used.

- shut-off valve

Install the shut-off valve as close to S1155 as possible.

- enclosed filterball

Install the filterball as close to S1155 as possible.

If filling connection KB25/KB32 is used, the enclosed filterball does not need to be fitted.

- vent valve

When necessary you should install venting valves in the brine system.

In the case of connection to an open groundwater system, an intermediate frost-protected circuit must be provided, because of the risk of dirt and freezing in the evaporator. This requires an extra heat exchanger.

Side connection

It is possible to angle the brine connections, for connection to the side instead of top connection.

HEATING MEDIUM



A climate system is a system that regulates indoor comfort with the help of the control system in S1155 and for example radiators, underfloor heating/cooling, fan convectors etc.

- Install all necessary safety devices, shut-off valves (as close to the heat pump as possible) and the enclosed filterball.
- Install safety valve. The recommended opening pressure is 0.25 MPa (2.5 bar). For information about max. opening pressure, see the technical specifications.
- When connecting to a system with thermostats on all radiators (or underfloor heating coils), either a bypass valve must be fitted or some of the thermostats must be removed to ensure there is sufficient flow.

COLD AND HOT WATER



If S1155 is not docked to a water heater, the connection for the water heater must be plugged.

Any docked hot water heater must be fitted with

- necessary set of valves.
- A mixer valve must also be installed, if the factory setting for hot water is changed. National regulations must be observed.
- The safety valve must have max. 1.0 MPa (10.0 bar) opening pressure, and be installed on the incoming domestic water line.

Ensure that incoming water is clean. When using a private well, it may be necessary to supplement with an extra water filter.

For more information see nibe.se.

Guideline values for collectors

The length of the collector hose varies depending on the rock/soil conditions, climate zone and on the climate system (radiators or underfloor heating) and the heating requirement of the building. Each installation must be sized individually.

Max. length per coil for the collector should not exceed 400 m.

In those cases where it is necessary to have several collectors, these should be connected in parallel with the possibility for adjusting the flow of the relevant coil.

For surface soil heat, the hose should be buried at a depth determined by local conditions and the distance between the hoses should be at least 1 metre.

For several bore holes, the distance between the holes must be determined according to local conditions.

Ensure the collector hose rises constantly towards the heat pump to avoid air pockets. If this is not possible, airvents should be used.

Because the temperature of the brine system can fall below 0 °C, it must be protected against freezing down to -15 °C. When making the volume calculation, use 1 litre of ready mixed brine per metre of collector hose (applies when using PEM-hose 40x2.4 PN 6.3) as a guide value.

Installation alternative

VENTILATION RECOVERY



The installation can be supplemented with the exhaust air module NIBE FLM S45 to provide ventilation recovery. FLM S45 is equipped with a built-in fan specially designed to combine recovery of

mechanical exhaust air with an energy collector in rock or in the ground.

- Pipes and other cold surfaces must be insulated with diffusion-proof material to prevent condensation.
- The brine system must be supplied with a pressure expansion vessel. If there is a level vessel this should be replaced.

FREE COOLING



The accessory PCS 44 allows the connection of passive cooling, for example with fan coils. The cooling system is connected to the heat pump brine circuit, whereby cooling is supplied from the collector via a circulation pump and shunt valve.

- Pipes and other cold surfaces must be insulated with diffusion-proof material to prevent condensation.
- Where the cooling demand is high, fan convectors with drip trays and drain connection are needed.
- The brine system must be supplied with a pressure expansion vessel. If there is a level vessel this should be replaced.

TWO OR MORE CLIMATE SYSTEMS



In buildings with several climate systems that require different supply temperatures, the accessory ECS 40/ECS 41 can be connected.

A shunt valve then lowers the temperature to the underfloor heating system, for example.

POOL



With the POOL 40 accessory, you can heat the pool with your system.

During pool heating, the heating medium circulates between the S1155 and the pool exchanger using the heat pump's internal circulation pump.

Functions

Control, general

The indoor temperature depends on several different factors. Sunlight and heat emissions from people and household machines are normally sufficient to keep the house warm during the warm seasons. When it gets colder outside, the climate system needs to help heat the house. The colder it is outside, the warmer radiators and underfloor heating systems have to be.

The heat pump is controlled by built-in supply and return brine temperature sensors (collector). Brine return temperatures can, if necessary, be limited to a minimum e.g. for ground water systems.

Control of the heat production is performed based on the "floating condensing" principle, which means that the temperature level needed for heating at a specific outdoor temperature is produced based on collected values from the outdoor and supply temperature sensors. The room sensor can also be used to compensate the deviation in room temperature.

Heat production



The supply of heat to the house is regulated in accordance with the selected heating curve setting. After adjustment, the correct amount of heat for the current outdoor temperature is supplied. The supply temperature of the heat pump will oscillate around the theoretically required value.

OWN CURVE

S1155 has pre-programmed non-linear heating curves. It is also possible to create your own defined curve. This is an individual linear curve with a number of break points. You select break points and the associated temperatures.

Hot water production



If the water heater is docked to S1155 and there is a hot water demand, the heat pump's software control prioritizes the hot water charging mode with optimal heat pump power.

Hot water charging starts when the temperature has fallen to the set start temperature. Hot water charging stops when the hot water temperature at the hot water sensor has been reached.

For temporary higher hot water demand, there is a function called "More hot water".

With the Smart Control function activated, S1155 learns how much hot water is used and when. The Smart Control function memorises the previous week's hot water consumption and adapts the hot water temperature for the coming week to ensure minimal energy consumption.

It is also possible to set S1155 in holiday mode, which means that the lowest possible temperature is achieved without the risk of freezing.

Multi-installation



Several heat pumps can be interconnected by selecting one heat pump as the main unit and the others as subordinate heat pumps.

Ground source heat pump models with multi-installation functionality from NIBE can be connected to S1155.

A further eight heat pumps can be connected to the main unit. In systems with several heat pumps, each pump must have a unique name. Only one heat pump can be "Main unit" and only one can be, for example, "Heat pump 5".

External temperature sensors and control signals must only be connected to the main unit, except for external control of the compressor module.

Additional heat only



S1155 can be used exclusively as an additional heater, (max 9 kW) to produce heat and any hot water, for example before the collector system is complete.

Alarm indications



In the event of an alarm, a malfunction has occurred and the status lamp shines with a steady red light. You receive information about the alarm in the smartguide on the display.

Floor drying



S1155 has an integrated underfloor drying function. This allows for controlled drying of concrete slabs. It is possible to create your own program or to follow a pre-programmed time and temperature schedule.

Brine control



For users who are going to replace an existing heat pump.

The risk of over-exploiting the collector system is reduced with the smart integrated brine control. This function can be used when replacing older heat pump systems where the collector may be undersized for a modern heat pump with a higher COP and SCOP.

An undersized collector can result in additional heat being required to assist on the coldest days of the year.

myUplink



With myUplink you can control the installation – where and when you want. In the event of any malfunction, you receive an alarm directly to your e-mail or a push notification to the myUplink app, which allows you to take prompt action.

Visit myuplink.com for more information.

SPECIFICATION

You need the following in order for myUplink to be able to communicate with your S1155:

- wireless network or network cable
- Internet connection
- account on myuplink.com

We recommend our mobile apps for myUplink.

RANGE OF SERVICES

myUplink gives you access to various levels of service. The base level is included and, apart from this, you can choose two premium services for a fixed annual fee (the fee varies depending on the functions selected).

Service level	Basic	Premium extended history	Premium change settings
Viewer	X	X	X
Alarm	X	X	X
History	X	X	X
Extended history	-	X	-
Manage	-	-	X

MOBILE APPS FOR MYUPLINK

The mobile apps can be downloaded free of charge from where you usually download your mobile apps. Logging into the mobile app is performed using the same account details as on myuplink.com.

SMART HOME

When you have a smart home system that can communicate with myUplink, you can control the installation via an app by activating the "smart home" function.

By allowing connected units to communicate with myUplink, your heating system becomes a natural part of your homesmart home and gives you the opportunity to optimise the operation.

Remember that the "smart home" function requires myUplink in order to work.

Wireless accessories



To benefit from S1155's full potential, the wireless accessories are the solution. This means new opportunities for you, and provides a more demand-adapted indoor comfort and lower energy consumption.

With a S1155 connected, you are already able to control and monitor your heating system easily via myUplink. With the new smart accessories, you can enjoy an even better and more comfortable life.

The display



S1155 is controlled using a clear and easy to use display.

Instructions, settings and operational information are shown on the display. You can easily navigate between the different menus and options to set the comfort or obtain the information you require.

The display unit is equipped with a USB socket that can be used to update the software and save logged information in S1155.

If you connect the product to the network, you can upgrade the software without using the USB port. See section "myUplink".

Visit myuplink.com and click the "Software" tab to download the latest software for your installation.

Technical data

Dimensions

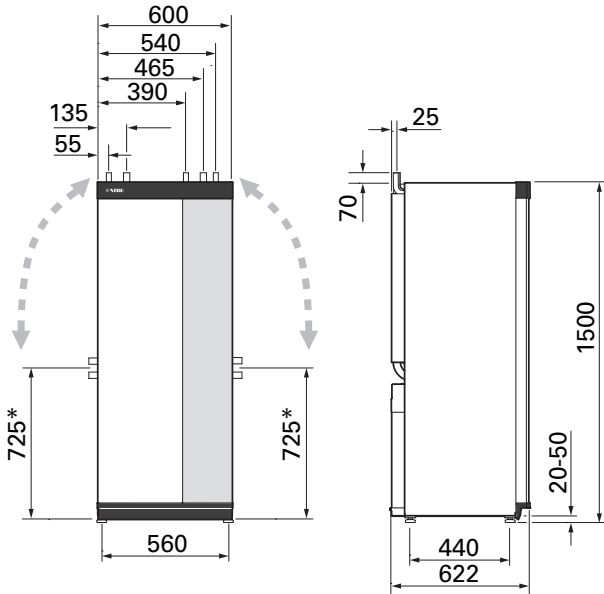

* Can be angled for side connection

Pipe connections

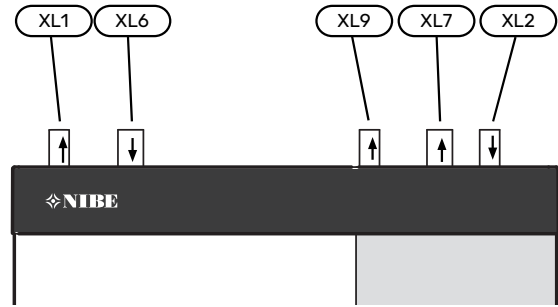

PIPE DIMENSIONS

Connection		6 kW	12 kW	16 kW	25 kW
(XL1)/(XL2) Heating medium supply/return ext. Ø	(mm)	22	28		35
(XL9) Connection water heater ext. Ø	(mm)	22	28		35
(XL6)/(XL7) Brine in/out ext. Ø	(mm)		28		35

Technical specifications

ELECTRICAL DATA

1x230 V

S1155-6		
Rated voltage		230V ~ 50Hz
Max operating current including 0 – 0.5 kW immersion heater (Recommended fuse rating).	A _{rms}	15(16)
Max operating current including 1 – 1.5 kW immersion heater (Recommended fuse rating).	A _{rms}	20(20)
Max operating current including 2 – 2.5 kW immersion heater (Recommended fuse rating).	A _{rms}	24(25)
Max operating current including 3 – 4 kW immersion heater (Recommended fuse rating).	A _{rms}	31(32)
Max operating current including 4.5 kW immersion heater (Recommended fuse rating).	A _{rms}	33(40)
Additional power	kW	0.5/1/1.5/2/2.5/3 /3.5/4/4.5

S1155-12		
Rated voltage		230 V ~ 50 Hz
Max operating current including 0 – 1 kW immersion heater (Recommended fuse rating).	A _{rms}	26(32)
Max operating current including 2 – 4 kW immersion heater (Recommended fuse rating).	A _{rms}	39(40)
Max operating current including 5 – 7 kW immersion heater (Recommended fuse rating).	A _{rms}	52(63)
Additional power	kW	1/2/3/4/5/6/7

3x230 V

S1155-6		
Rated voltage		230V 3 ~ 50Hz
Max operating current including 0 – 1 kW immersion heater (Recommended fuse rating).	A _{rms}	16(16)
Max operating current including 1.5 – 4.5 kW immersion heater (Recommended fuse rating).	A _{rms}	20(20)
Additional power	kW	0.5/1/1.5/2/2.5/3 /3.5/4/4.5

S1155-12		
Rated voltage		230V 3 ~ 50Hz
Max operating current including 0 kW immersion heater (Recommended fuse rating).	A _{rms}	22(25)
Max operating current including 2 – 4 kW immersion heater (Recommended fuse rating).	A _{rms}	28(32)
Max operating current including 6 kW immersion heater (Recommended fuse rating).	A _{rms}	36(40)
Max operating current including 9 kW immersion heater (Recommended fuse rating).	A _{rms}	46(50)
Additional power	kW	1/2/3/4/5/6/7/8/9

3x400 V

S1155-6		
Rated voltage		400V 3N ~ 50Hz
Max operating current including 0 kW immersion heater (Recommended fuse rating).	A _{rms}	12(16)
Max operating current including 0.5 – 6.5 kW immersion heater (Recommended fuse rating).	A _{rms}	16(16)
Additional power	kW	0.5 – 6.5

S1155-12		
Rated voltage		400V 3N ~ 50Hz
Max operating current including 0 kW immersion heater (Recommended fuse rating).	A _{rms}	9(10)
Max operating current including 1 kW immersion heater (Recommended fuse rating).	A _{rms}	12(16)
Max operating current including 2 – 4 kW immersion heater (Recommended fuse rating).	A _{rms}	16(20)
Max operating current including 5 – 7 kW immersion heater (Recommended fuse rating).	A _{rms}	21(25)
Max operating current including 9 kW immersion heater, requires reconnection (Recommended fuse rating).	A _{rms}	24(25)
Additional power	kW	1 – 9

S1155-16		
Rated voltage		400V 3N ~ 50Hz
Max operating current including 0 kW immersion heater (Recommended fuse rating).	A _{rms}	10(10)
Max operating current including 1 kW immersion heater (Recommended fuse rating).	A _{rms}	13(16)
Max operating current including 2 – 4 kW immersion heater (Recommended fuse rating).	A _{rms}	17(20)
Max operating current including 5 – 7 kW immersion heater (Recommended fuse rating).	A _{rms}	21(25)
Max operating current including 9 kW immersion heater, requires reconnection (Recommended fuse rating).	A _{rms}	24(25)
Additional power	kW	1 – 9
Short circuit power (Ssc) ¹	MVA	2.2

¹ This equipment complies with IEC 61000-3-12, on the condition that the short circuit power Ssc is greater than or equal to 2.2 MVA at the connection point between the customer installation's electrical supply and the mains network. It is the responsibility of the installer or user of the equipment to ensure, through consultation with the distribution network operator if required, that the equipment is only connected to a supply with a short circuit power Ssc equal to or greater than 2.2 MVA.

S1155-25		
Rated voltage		400V 3N - 50Hz
Max operating current including 0 kW immersion heater (Recommended fuse rating).	A _{rms}	14(16)
Max operating current including 1 kW immersion heater (Recommended fuse rating).	A _{rms}	18(20)
Max operating current including 2 - 4 kW immersion heater (Recommended fuse rating).	A _{rms}	22(25)
Max operating current including 5 - 7 kW immersion heater (Recommended fuse rating).	A _{rms}	27(32)
Max operating current including 9 kW immersion heater, requires reconnection (Recommended fuse rating).	A _{rms}	29(32)
Additional power	kW	1 - 9

The following data only applies to S1155 3x400 V. S1155 is also available with energy meter, passive cooling, and in voltage versions 1x230 V and 3x230 V. Contact your NIBE dealer for more information.

Model		S1155-6	S1155-12	S1155-16	S1155-25
Output data according to EN 14511					
Heating capacity (P_H)	kW	1.5 - 6	3 - 12	4 - 16	6 - 25
0/35 nominal					
Heating capacity (P _H)	kW	3.15	5.06	8.89	12.68
Supplied power (P _E)	kW	0.67	1.04	1.83	2.71
COP		4.72	4.87	4.85	4.68
0/45 nominal					
Heating capacity (P _H)	kW	2.87	4.78	8.63	11.83
Supplied power (P _E)	kW	0.79	1.27	2.29	3.38
COP		3.61	3.75	3.77	3.50
10/35 nominal					
Heating capacity (P _H)	kW	4.30	6.33	11.22	16.94
Supplied power (P _E)	kW	0.66	1.03	1.84	2.67
COP		6.49	6.12	6.11	6.34
10/45 nominal					
Heating capacity (P _H)	kW	3.98	5.98	10.92	15.98
Supplied power (P _E)	kW	0.83	1.30	2.32	3.40
COP		4.79	4.59	4.72	4.70
SCOP according to EN 14825					
Rated heating output (P _{designh})	kW	6	12	16	25
SCOP cold climate, 35 °C / 55 °C		5.5 / 4.1	5.4 / 4.3	5.5 / 4.2	5.5 / 4.1
SCOP average climate, 35 °C / 55 °C		5.2 / 4.0	5.2 / 4.1	5.2 / 4.1	5.2 / 4.0
Energy rating, average climate					
The product's room heating efficiency class 35 °C / 55 °C ¹		A+++ / A+++	A+++ / A+++	A+++ / A+++	A+++ / A+++
The system's room heating efficiency class 35 °C / 55 °C ²		A+++ / A+++	A+++ / A+++	A+++ / A+++	A+++ / A+++
Efficiency class hot water heating / declared tap profile with water heater ³		A / XL VPB S300	A / XXL VPB S300	A / XXL VPB S300	-
Noise					
Sound power level (L _{WA}) _{EN 12102} at 0/35	dB(A)	36 - 43	36 - 47	36 - 47	36 - 47
Sound pressure level (L _{PA}) calculated values according to EN ISO 11203 at 0/35 and 1m range	dB(A)	21 - 28	21 - 32	21 - 32	21 - 32
Electrical data					
Output, Brine pump	W	3 - 140	2 - 180	2 - 180	16 - 310
Output, Heating medium pump	W	2 - 60	2 - 60	3 - 140	3 - 140
Enclosure class		IPx1B			
Equipment Compliant with IEC 61000-3-12					
For Connection Design Purposes, Compliant with IEC 61000-3-3 technical requirements					
WLAN					
2.412 - 2.484 GHz max power	dbm	11			
Wireless units					
2.405 - 2.480 GHz max power	dbm	4			
Refrigerant circuit					
Type of refrigerant		R407C	R407C	R407C	R410A
GWP refrigerant		1,774	1,774	1,774	2,088
Fill amount	kg	1.16	2.0	2.2	2.1
CO ₂ equivalent	ton	2.06	3.55	3.90	4.39
Brine circuit					
Min/max system pressure brine	MPa (bar)	0.05 (0.5) / 0.45 (4.5)			
Nominal flow	l/s	0.18	0.29	0.51	0.74

Model		S1155-6	S1155-12	S1155-16	S1155-25
Flow at Pdesignh ⁴	l/s	0.29	0.64	0.66	1.25
Max external avail. press at nom flow	kPa	95	115	95	70
Max external available press at Pdesignh	kPa	85	70	72	50
Min/Max incoming Brine temp	°C	see diagram			
Min. outgoing brine temp.	°C	-12			
Heating medium circuit					
Min/Max system pressure heating medium	MPa (bar)	0.05 (0.5) / 0.45 (4.5)			
Nominal flow	l/s	0.08	0.12	0.22	0.30
Flow at Pdesignh	l/s	0.16	0.38	0.50	0.73
Max external avail. press at nom flow	kPa	73	73	95	90
Max external available press at Pdesignh	kPa	71	55	75	60
Min/max HM-temp	°C	see diagram			
Pipe connections					
Brine ext diam. CU pipe	mm	28	28	28	35
Heating medium ext diam. CU pipes	mm	22	28	28	35
Connection, hot water heater ext diam	mm	22	28	28	35
Compressor oil					
Oil type		POE			
Oil volume	l	0.68	0.9	1.45	1.45
Dimensions and weight					
Width x Depth x Height	mm	600 x 620 x 1,500			
Ceiling height ⁵	mm	1,670			
Weight complete heat pump	kg	139	167	172	205
Weight only cooling module	kg	112	230 V: 110 400 V: 120	112	140
Substances according to Directive (EG) no. 1907/2006, article 33 (Reach)		Lead in brass components			
Part number, 1x230 V		065 446	065 438	-	-
Part number, 3x230 V		065 448	065 440	-	-
Part number, 3x400 V T		-	065 506	-	-
Part number, 3x400 V		065 447	065 439	065 443	065 498

1 Scale for the product's efficiency class room heating: A+++ to D.

2 Scale for the system's efficiency class room heating: A+++ to G. Reported efficiency for the system takes the product's temperature regulator into account.

3 Scale for efficiency class hot water: A+ to F.

4 For 16 kW, the value is given at Delta T=4°, for others at Delta T=3°

5 With feet removed, the height is approx. 1,650 mm.

WORKING RANGE HEAT PUMP, COMPRESSOR OPERATION

The compressor provides a supply temperature up to 65 °C at -5 °C incoming brine temperature.

The working range below 75 % for S1155-6 and the entire working range for S1155-12, -16.

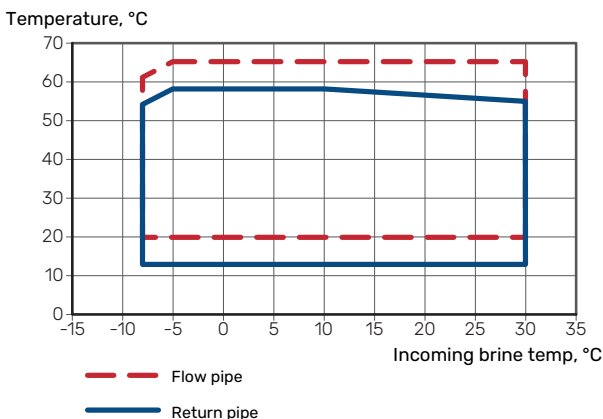

Working range for S1155-25

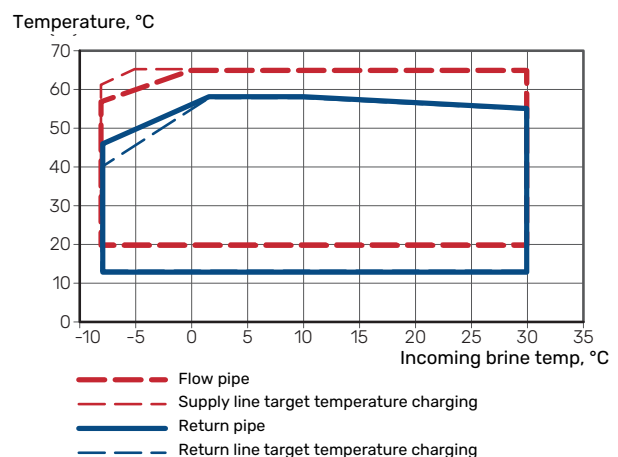

The working range above 75 % for S1155-6

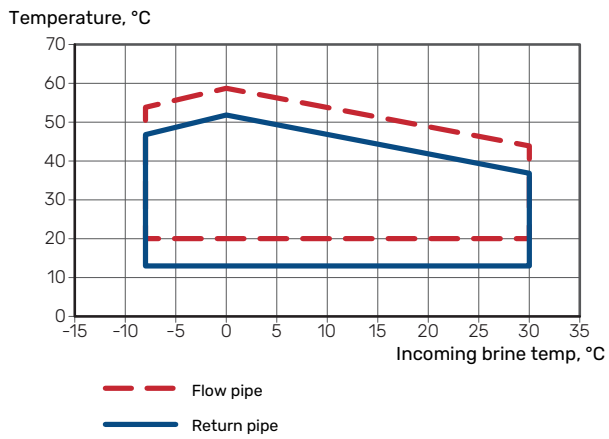

Unlocking is required for S1155-6 to operate above 75% compressor speed. This can produce a louder noise level than the value stated in the technical specifications.

DIAGRAM, DIMENSIONING COMPRESSOR SPEED

Heating mode 35 °C

Diagram for dimensioning a heat pump. The percentage shows approximate compressor speed.

S1155-6

Specified heating output, kW

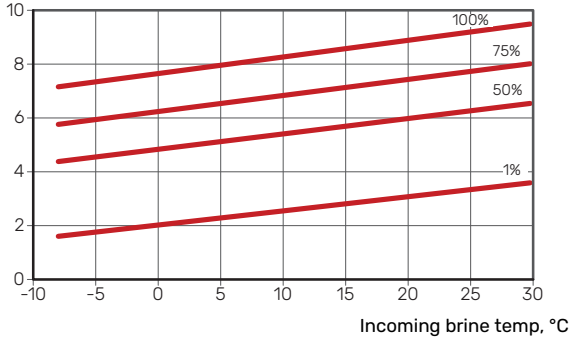

Cooling mode (Accessory required)

To dimension heating dump, see the diagram for heating operation.

Supply temperature, heating medium 35 °C

S1155-6

Specified cooling output, kW

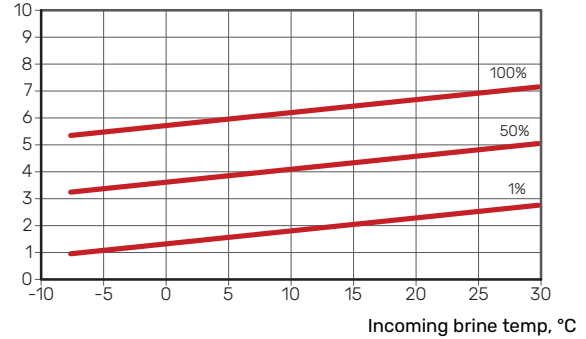

S1155-12

Specified heating output, kW

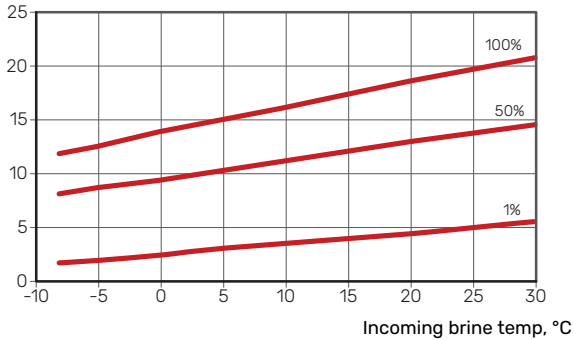

S1155-12

Specified cooling output, kW

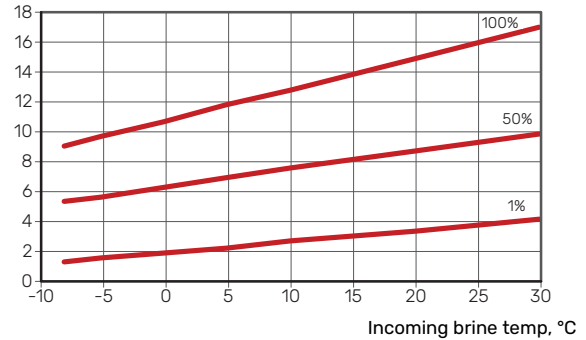

S1155-16

Specified heating output, kW

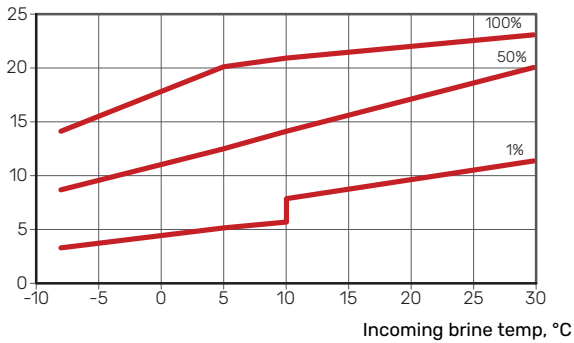

S1155-16

Specified cooling output, kW

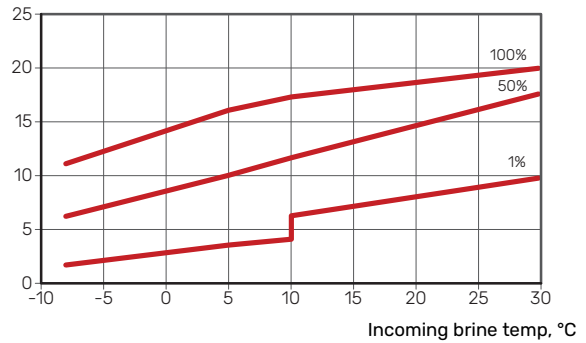

S1155-25

Specified heating output, kW

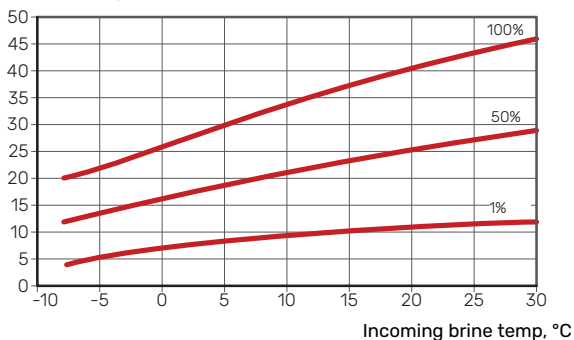

S1155-25

Specified cooling output, kW

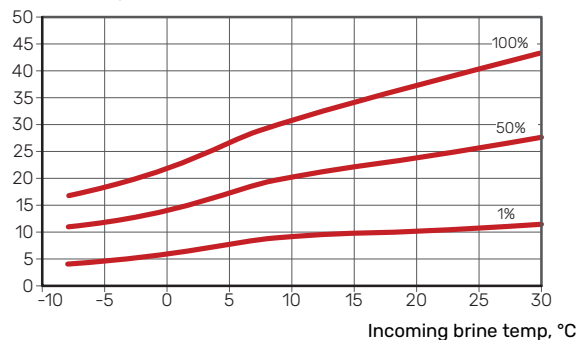

Supply temperature, heating medium 50 °C

S1155-6

Specified cooling output, kW

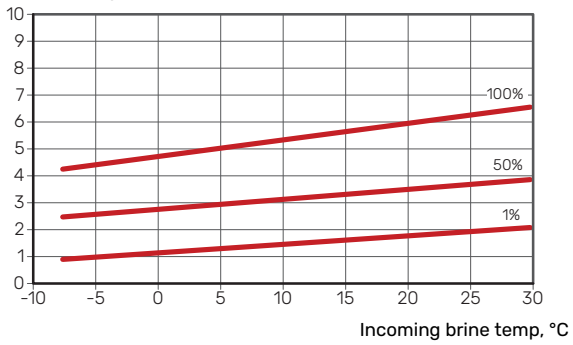

S1155-12

Specified cooling output, kW

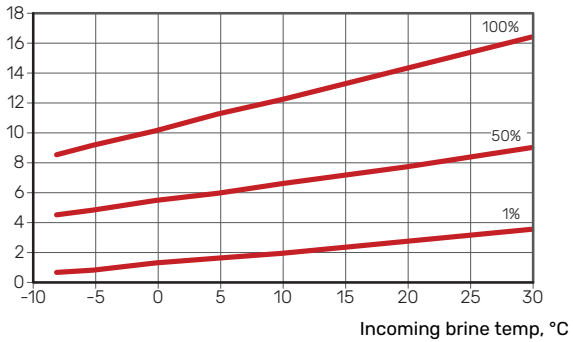

S1155-16

Specified cooling output, kW

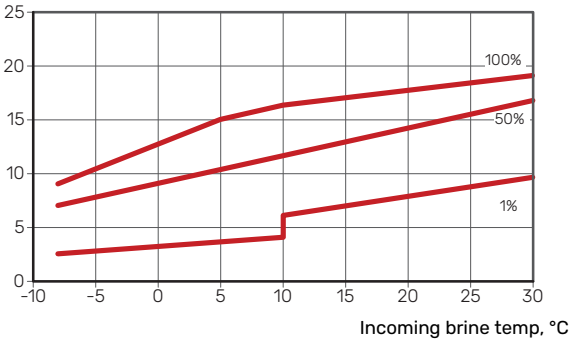

S1155-25

Specified cooling output, kW

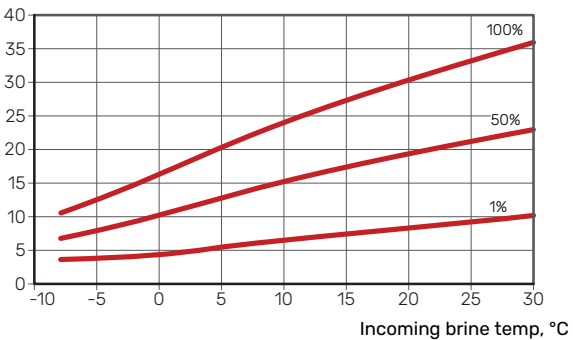

PUMP CAPACITY DIAGRAM

Brine side

To set the correct flow in the brine system, the brine pump must run at the correct speed. S1155 has a brine pump that is controlled automatically in standard mode.

For optimum operation when several heat pumps are installed in a multi-installation, all heat pumps should have the same compressor size.

— Available pressure, kPa
— Electrical output, W

S1155 25 kW

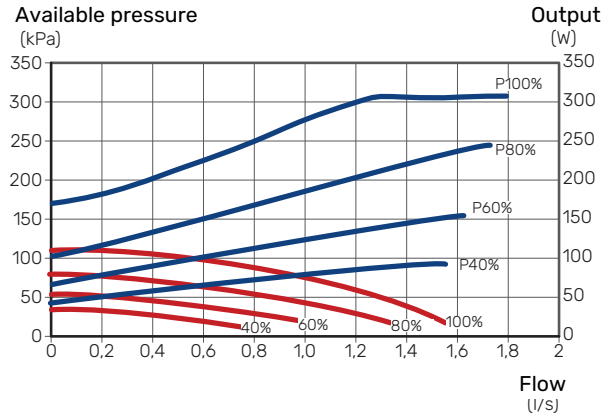

S1155 6 kW

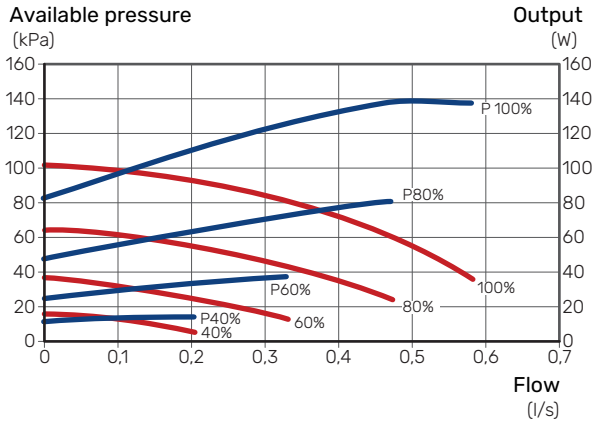

S1155 12 kW

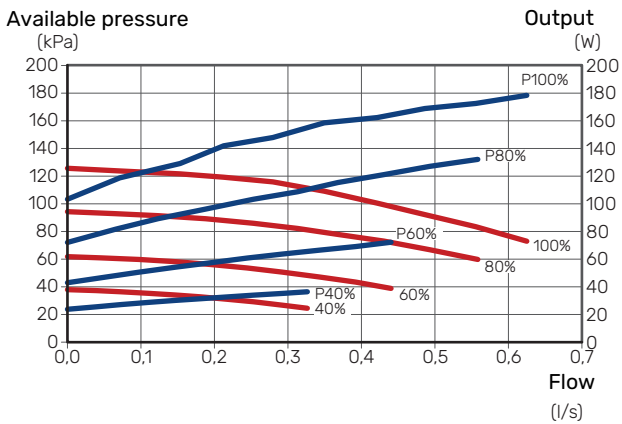

S1155 16 kW

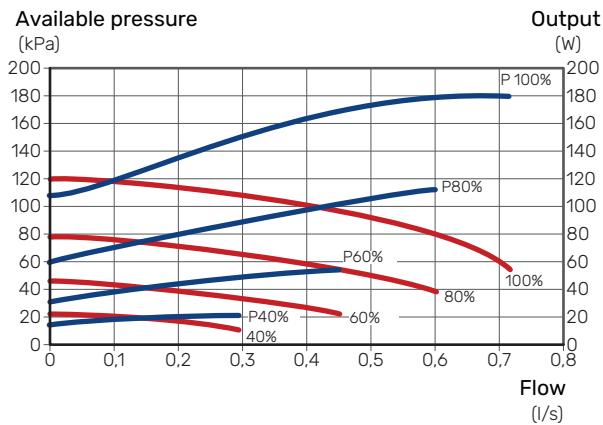

Climate system

To set the correct flow in the climate system, the heating medium pump must run at the correct speed. S1155 has a heating medium pump that can be automatically controlled in standard mode.

- Available pressure, kPa
- Electrical output, W

S1155 6 kW

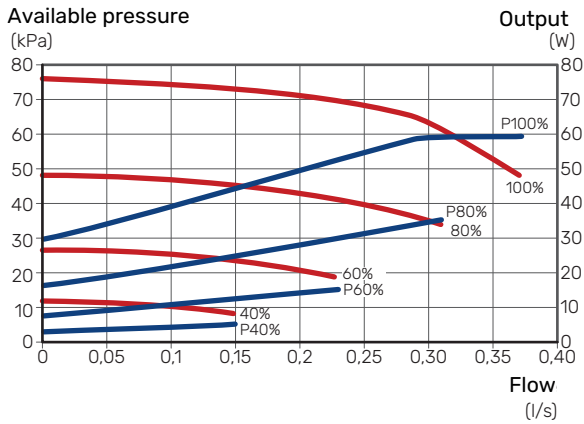

S1155 12 kW

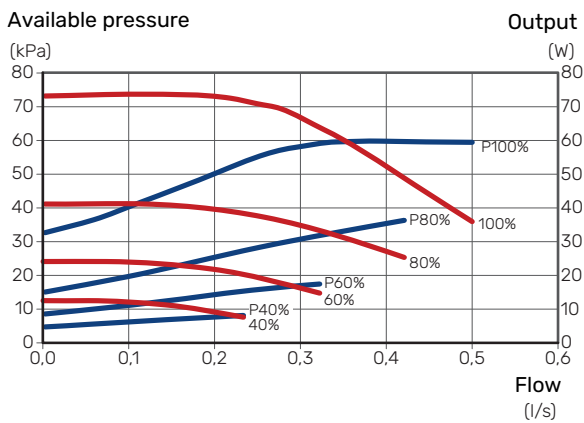

S1155 16 kW

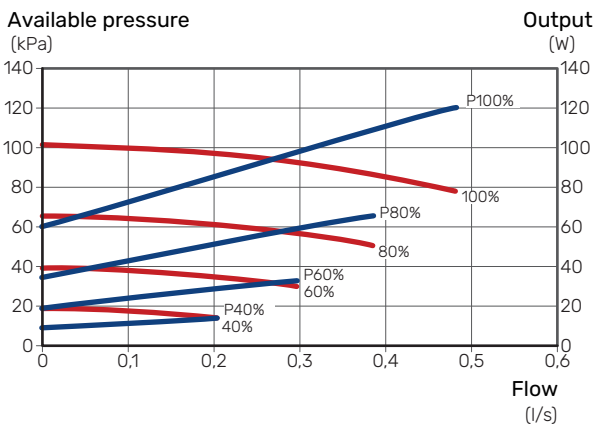

S1155 25 kW

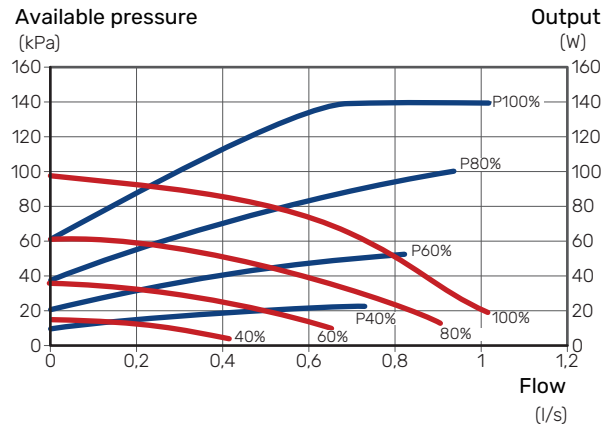

Accessories

Not all accessories are available on all markets.

Detailed information about the accessories and complete accessories list available at nibe.se.

ACTIVE/PASSIVE COOLING HPAC S40

The accessory HPAC S40 is a climate exchange module that is to be included in a system with S1155.

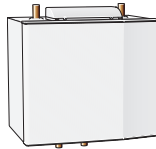

EXTRA SHUNT GROUP ECS 40/ECS 41

This accessory is used when S1155 is installed in houses with two or more different heating systems that require different supply temperatures.

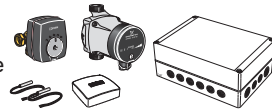

FREE COOLING PCS 44

This accessory is used when S1155 is installed in an installation with passive cooling.

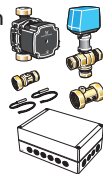

EXHAUST AIR MODULE FLM S45

FLM S45 is an exhaust air module designed to combine recovery of mechanical exhaust air with ground source heating.

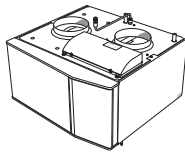

HRV UNIT ERS

This accessory is used to supply the accommodation with energy that has been recovered from the ventilation air. The unit ventilates the house and heats the supply air as necessary.

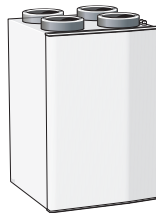

BASE EXTENSION EF 45

This accessory is used to create a larger connection area under S1155.

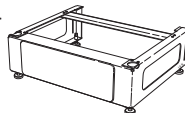

PASSIVE COOLING PCM S40/S42

PCM S40/42 makes it possible to obtain passive cooling from rock, groundwater or surface soil collectors.

Max. 17 kW.

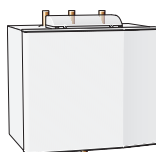

POOL HEATING POOL 40

POOL 40 is used to enable pool heating with S1155.

Max. 17 kW.

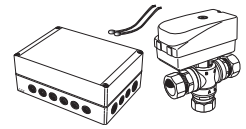

FILLING VALVE KIT, BRINE 25/32

Valve kit for filling brine in the collector hose. Includes particle filter and insulation.

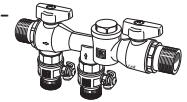

ROOM UNIT RMU S40

The room unit is an accessory with a built-in room sensor, which allows the control and monitoring of S1155 to be carried out in a different part of your home to where it is located.



ACCESSORY CARD AXC 40

This accessory is used to enable connection and control of shunt controlled additional heat, step controlled additional heat, external circulation pump or ground water pump.



WIRELESS ACCESSORIES

It is possible to connect wireless accessories to S1155, e.g. room, humidity, CO₂ sensors.

For more information, as well as a complete list of all available wireless accessories, see myuplink.com.



WATER HEATER/ACCUMULATOR TANK

For information regarding suitable water heaters, see nibe.se.









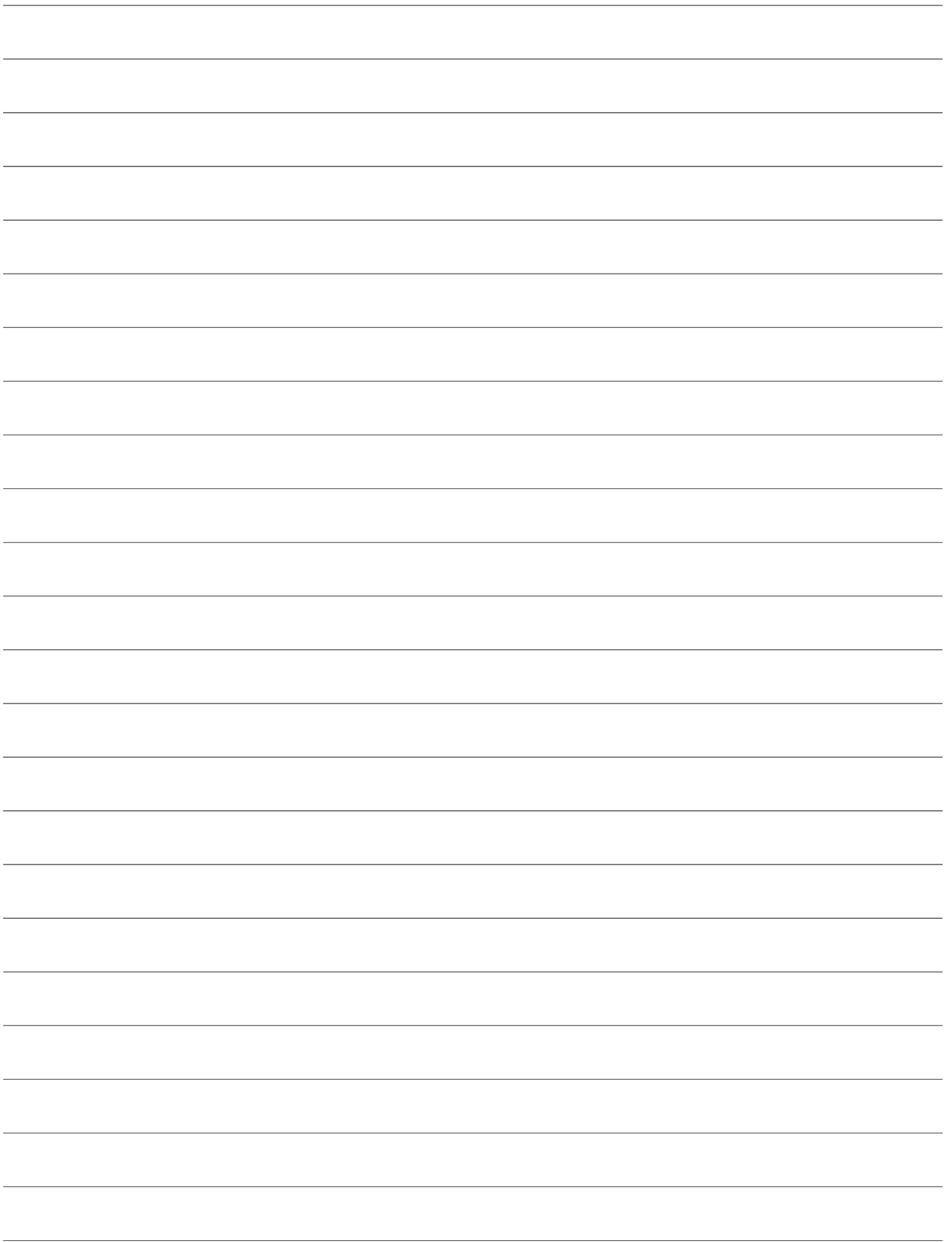

Sustainable energy solutions since 1952

NIBE has been manufacturing energy-efficient and sustainable climate solutions for your home for 70 years. It all began in Markaryd, in the southern Swedish province of Småland, and we recognise our Nordic heritage by utilising the power of nature. We combine renewable energy with smart technology to offer efficient solutions, allowing us to work together to create a more sustainable future.

Regardless of whether it is a chilly winter's day or a warm afternoon in the summer sun, we need a balanced indoor climate that allows us to enjoy a comfortable life, whatever the weather. Our extensive range of products supply your home with cooling, heating, ventilation and hot water, making it possible for you to create a pleasant indoor climate with little impact on the environment.

NIBE Energy Systems
Box 14, SE-285 21 Markaryd
nibe.se



This product sheet is a publication from NIBE Energy Systems. All product illustrations, facts and data are based on current information at the time of the publication's approval. NIBE Energy Systems makes reservations for any factual or printing errors in this product sheet.